

Exploded View

Sale Model:

AHU30-SG2

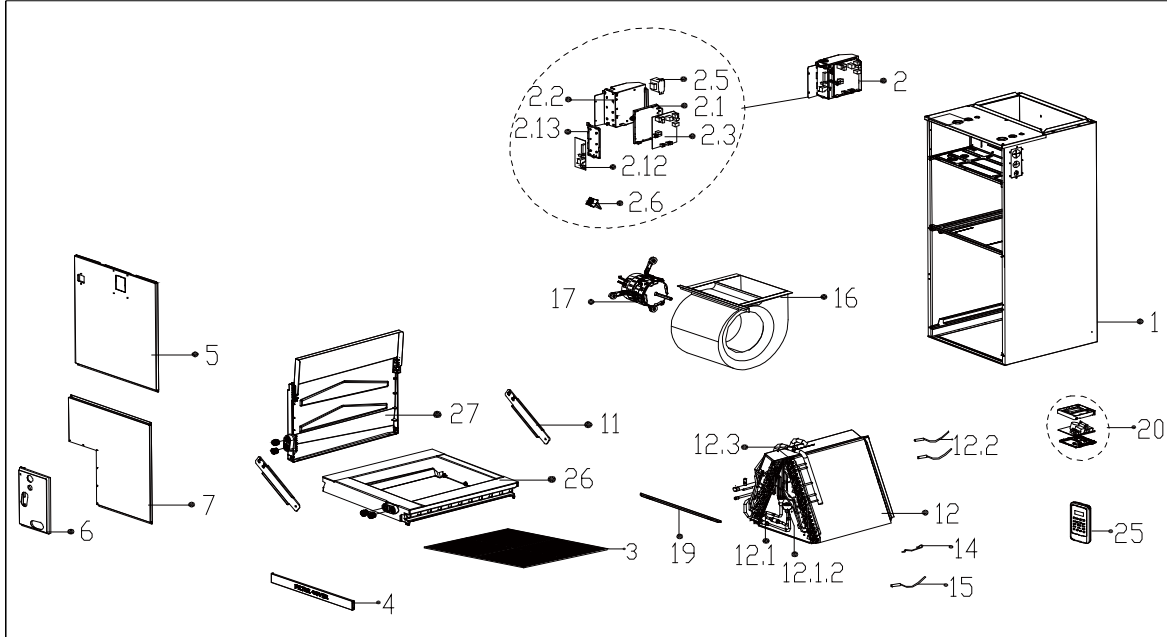

No.	Part Name	Quantity	BOM Code	Remark1	Remark2
1	Chassis assembly	1	12223100000659		
2	Duct electronic control box subassembly	1	17223000007762		
2.1	Installation plate for main board	1.0	12123000000920		
2.2	E-part box Subassembly	1.0	12223100000631		
2.3	Duct main control board subassembly	1.0	17123000007977		
2.5	Linear Transformer	1.0	11203103000087		
2.6	Wire joint	1.0	17400401000085		
2.12	Data transfer module control board printed board s	1.0	17122000054055		
2.13	Bracket of main control board	1.0	12120300000522		
3	Air filter	1	12223000014171		
4	Dust mesh	1	12223100000652		
5	Upper Cover Plate assembly	1	12223100000667		
6	Clamp for connecting pipe assembly	1	12223100000651		
7	Under Cover Plate assembly	1	12223100000653		
11	Bracket for Water collector	2	12223100000663		
12	Evaporator assembly	1	15823100000523		
12.1	Evaporator inlet pipe subassembly	1.0	15123000012631		
12.1.2	Electronic expansion valve body	1.0	15500213000265		
12.2	T2 Pipe Temperature Sensor	1.0	11201007003437		
12.2	T2A、T2B Pipe temperature sensor	1.0	11201007004863		
12.3	Evaporator output tube assembly (aluminum tube)	1.0	15223000000288		
15	Room Temperature Sensor	1	11201007004864		
16	centrifuge fan assembly	1	12200101000253		
17	Brushless DC Motor	1	11002015013970		
19	Clamp for Cover Plate assembly	1	12223100000657		
20	Wired controller	1	17317100006115		
25	Remote controller	1	17317000A62645		
26	Main Water collector assembly	1	12123100000024		
27	Deputy Water collector assembly	1	12123100000028		