



CGS12CD(I)/CGS12CD(O)	12,000 BTU/H(208/230V)	Wall Mounted Heat Pump System
Location: _____	Approval: _____	
Engineer: _____	Date: _____	
Submitted to: _____	Construction: _____	
Submitted by: _____	Unit #: _____	
Reference: _____	Drawing #: _____	

Set Model	
Indoor unit model	CGS12CD(I)
Outdoor unit model	CGS12CD(O)
Certified	
AHRI	
UL	



SYSTEM PERFORMANCE DATA		
Power supply		
Normal Operational Voltage	(V, Ph, Hz)	208/230, 1, 60
Voltage Range	(V)	187-253
Electrical		
Minimum circuit ampacity	(A)	15
Max.fuse	(A)	15
Connection wiring		14*4 AWG
Cooling		
Rated Capacity	(Btu/h)	12000
Capacity Range	(Btu/h)	3800~13350
Power Input (Max)	(W)	1111
Rated current	(A)	4.9
SEER	(Btu/W)	20.5
EER	(Btu/W)	10.8
Heating at 47F		
Rated Capacity	(Btu/h)	12000
Capacity Range	(Btu/h)	2730~13900
Power Input (Max)	(W)	1039
Rated current	(A)	4.6
HSPF4	(Btu/W)	10.7
HSPF5	(Btu/W)	8.5
COP	W/W	3.38
Heating at 17F		
Max Capacity	(Btu/h)	9000

REFRIGERANT PIPE DATA		
Design pressure	(PSIG)	550/340
Refrigerant Type	(Oz)	R410A/28.6
Refrigerant precharge	(ft)	25.0
	(m)	7.6
Additional charge for each ft	(oz/ft)	0.16
	(g/ft)	15
Liquid side/ Gas side	(inch)	1/4" / 1/2"
	(mm)	φ6.35 / φ12.7
Max. pipe length	(ft)	82.0
	(m)	25.0
Max. difference in level	(ft)	32.8
	(m)	10.0
Connection method		(Flared)

INDOOR UNIT DATA		
Indoor fan motor		
Type		Cross-Flow
Model		ZKFP-13-8-4
Qty		1
Input	(W)	-
RLA	(A)	-
LRA	(A)	---
Winding Resistance	(Ω)	---
Capacitor	(uF)	---
Speed(Hi/Mi/Lo)	(r/min)	1250/1070/800
Air flow & Noise level		
Indoor air flow (Hi/Med/Lo) (l)	(CFM)	291.18/197.06/155.88
Indoor noise level (Hi/Med/L)	[dB(A)]	41/35/24
Dehumidification		
	(Pint/H)	---
Indoor unit		
Dimension (WxDxH)	(inch)	31.57x7.87x11.61
	(mm)	802x200x295
Packing(WxDxH)	(inch)	34.45x11.22x14.96
	(mm)	875x285x380
Net/Gross weight	(lbs.)	18.74/24.03
	(kg)	8.5/10.9

OUTDOOR UNIT DATA		
Compressor		
Type		KSN98D64UFZ3
Model		ROTARY
Brand		GMCC
Capacity	(Btu/h)	6585 / 10578
Input	(W)	292 / 765
Rated current (RLA)	(A)	-
Refrigerant oil/oil charge	(ml)	-
Throttle		Capillary
Outdoor fan motor		
Model		ZKFN-34-10-1-3
Qty		1
Input	(W)	--
RLA	(A)	--
Speed	(r/min)	780/700/600
Air flow & Noise level		
Outdoor air flow (Max.)	(CFM)	1235,29
Outdoor noise level	[dB(A)]	53.5
Outdoor unit		
Dimension (WxDxH)	(inch)	30.12x11.93x21.85

Indoor(cooling/ heating)	(Deg. °F)	60~90 / 32~86
	(Deg. °C)	16~32 / 0~30
Outdoor(cooling/heating)	(Deg. °F)	5~122 / 5~75
	(Deg. °C)	-15~50 / -15~24
Application area	(sq.ft)	172.22~247.57
	(m2)	16~23

Packing (W×D×H)	(mm)	765x303x555
	(inch)	34.92x13.27x24.02
Net/ Gross weight	(mm)	887x337x610
	(lbs.)	59.30/64.82
	(kg)	26.9/29.4

Indoor unit dimension

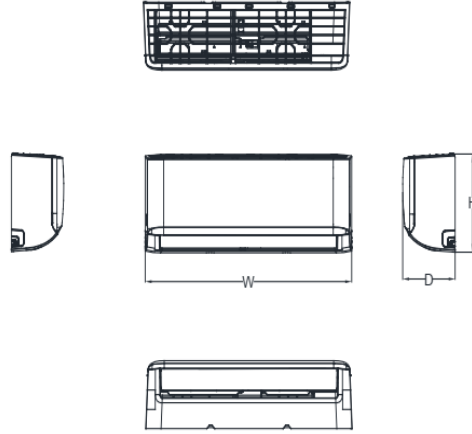

Capacity	Body Code	W(mm/inch)	D(mm/inch)	H(mm/inch)
6K-11K	A	729/28.7	200/7.87	292/11.5
8K-14K	B	802/31.57	200/7.87	295/11.61
12K-21K	C	971/38.23	228/8.98	321/12.64
18K-28K	D	1082/42.6	234/9.21	337/13.27
27K-36K	F	1259/49.57	283/11.14	362/14.25

Outdoor unit dimension

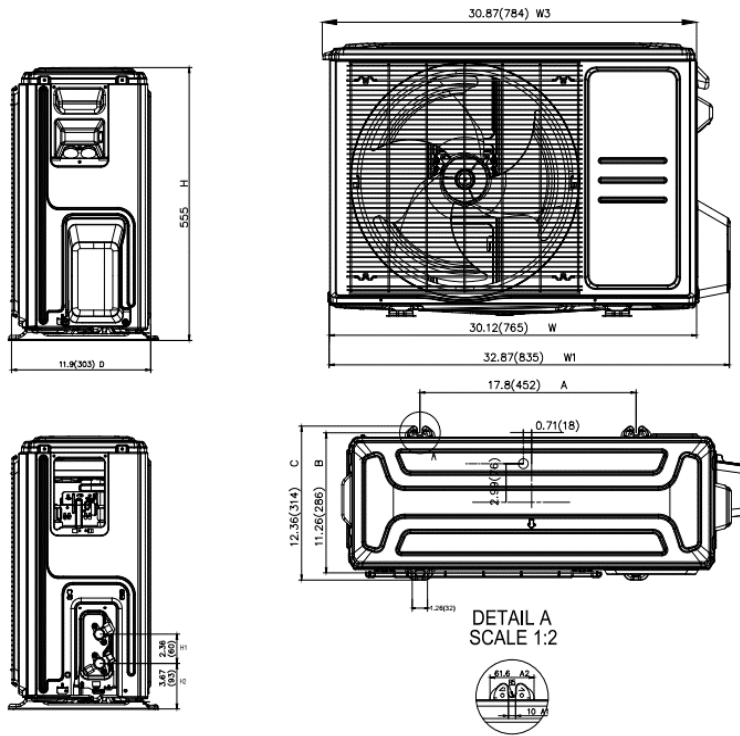



General Features

Wireless Remote with LCD Display

46F Heating

Sleep Mode

Silent Mode

Self Clean

Follow Me (optional)

Extended Performance Data

