

SUBMITTAL DATA SHEET



FPA-48DU/CZP48CD(O)	48,000 BTU/H(208/230V)	Wall Mounted Heat Pump System
Location: _____	Approval: _____	Date: _____
Engineer: _____	Construction: _____	Unit #: _____
Submitted to: _____	Drawing #: _____	
Submitted by: _____		
Reference: _____		

Set Model
 Indoor unit model FPA-48DU
 Outdoor unit model CZP48CD(O)

Certified

AHRI

CSA



SYSTEM PERFORMANCE DATA

Power supply		
Normal Operational Voltage	(V, Ph, Hz)	208/230, 1, 60
Voltage Range	(V)	187-253
Electrical		
Minimum circuit ampacity	(A)	36.5
Max.fuse	(A)	50.0
Connection wiring		14AWG*2 Stranded, shielded
Cooling		
Rated Capacity	(Btu/h)	48000
Capacity Range	(Btu/h)	15861~48000
Power Input (Max)	(W)	5170
Rated current	(A)	23.6
SEER	(Btu/W)	18
EER	(Btu/W)	9.3

Heating at 47F		
Rated Capacity	(Btu/h)	50000
Capacity Range	(Btu/h)	12159~50000
Power Input (Max)	(W)	5861
Rated current	(A)	25.5
HSPF4	(Btu/W)	11
HSPF5	(Btu/W)	9.4
COP	WW	2.50
Heating at 17F		
Max Capacity	(Btu/h)	34000

REFRIGERANT PIPE DATA

Design pressure	(PSIG)	550/340
Refrigerant Type	(Oz)	R410A/158.7
Refrigerant precharge	(ft)	25.0
	(m)	7.6
Additional charge for each ft	(oz/ft)	0.32
	(g/ft)	30
Liquid side/ Gas side	(inch)	Optional
	(mm)	Optional
Max. pipe length	(ft)	213.0
	(m)	65.0
Max. difference in level	(ft)	98.0
	(m)	30.0
Connection method		(Flared)

Indoor(cooling/ heating)	(Deg. °F)	/ No
	(Deg. °C)	72/147/167 / Yes
Outdoor(cooling/heating)	(Deg. °F)	5~122 / 5~75
	(Deg. °C)	-15~50 / -15~24
Application area	(sq.ft)	688.89~1011.81
	(m2)	64~94

INDOOR UNIT DATA

Indoor fan motor		
Type		Cross-Flow
Model		ZKFN-90-8-1
Qty		2
Input	(W)	96.0
RLA	(A)	-
LRA	(A)	---
Winding Resistance	(Ω)	---
Capacitor	(uF)	---
Speed(Hi/Mi/Lo)	(r/min)	1320/1200/1120
Air flow & Noise level		
Indoor air flow (Hi/Med/Lo) (No)	(CFM)	1352.94/1117.65/1000.00
Indoor noise level (Hi/Med/Lo)	[dB(A)]	55.0/49.5/44.5
Dehumidification		
	(Pint/H)	---
Indoor unit		
Dimension (WxDxH)	(inch)	64.96x26.57x9.25
	(mm)	1650x675x235
Packing(WxDxH)	(inch)	67.91x29.72x12.32
	(mm)	1725x755x318
Net/Gross weight	(lbs.)	87.74/102.29
	(kg)	39.8/46.4

OUTDOOR UNIT DATA

Compressor		
Type		KTQ420D1UMU
Model		ROTARY
Brand		GMCC
Capacity	(Btu/h)	44697
Input	(W)	3420
Rated current (RLA)	(A)	-
Refrigerant oil/oil charge	(ml)	INT01L-4639
Throttle		Capillary +EXV
Outdoor fan motor		
Model		ZKFN-85-8-22
Qty		2
Input	(W)	--
RLA	(A)	--
Speed	(r/min)	900/850/800/750
Air flow & Noise level		
Outdoor air flow (Max.)	(CFM)	4500.00
Outdoor noise level	[dB(A)]	63.5
Outdoor unit		
Dimension (WxDxH)	(inch)	37.48x16.34x52.48
	(mm)	952x415x1333
Packing (WxDxH)	(inch)	43.11x19.49x58.27
	(mm)	1095x495x1480
Net/ Gross weight	(lbs.)	219.14/249.12
	(kg)	99.4/113

Indoor unit dimension

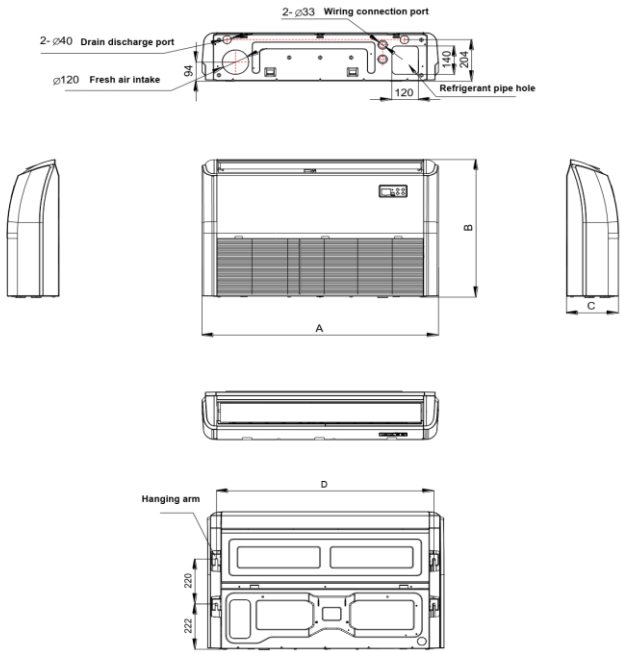

Capacity (Btu/h)	Unit	A	B	C	D
18K / 24K	mm	1068	675	235	983
	inch	42.05	26.57	9.25	38.70
36K	mm	1285	675	235	1200
	inch	50.59	26.57	9.25	47.24
48K/60K	mm	1650	675	235	1565
	inch	64.96	26.57	9.25	61.61

Outdoor unit dimension

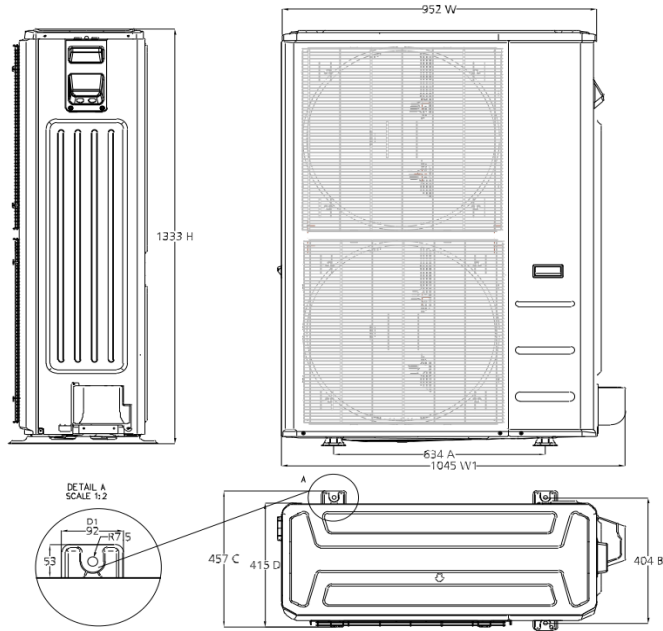

General Features

Wired controller(optional)

Weekly-time wired controller(optional)

Central controller

Long distance Alarm and ON/OFF controller(optional)

Build-in pump(optional)

3D airflow

Extended Performance Data

