

ComfortStar®

Installation Manual

**Outdoor Unit: CHD12CA-14, CHD18CD-14, CHD24CD-14,
CHD30CD-14, CHD36CD-14, CHD48CD-14**

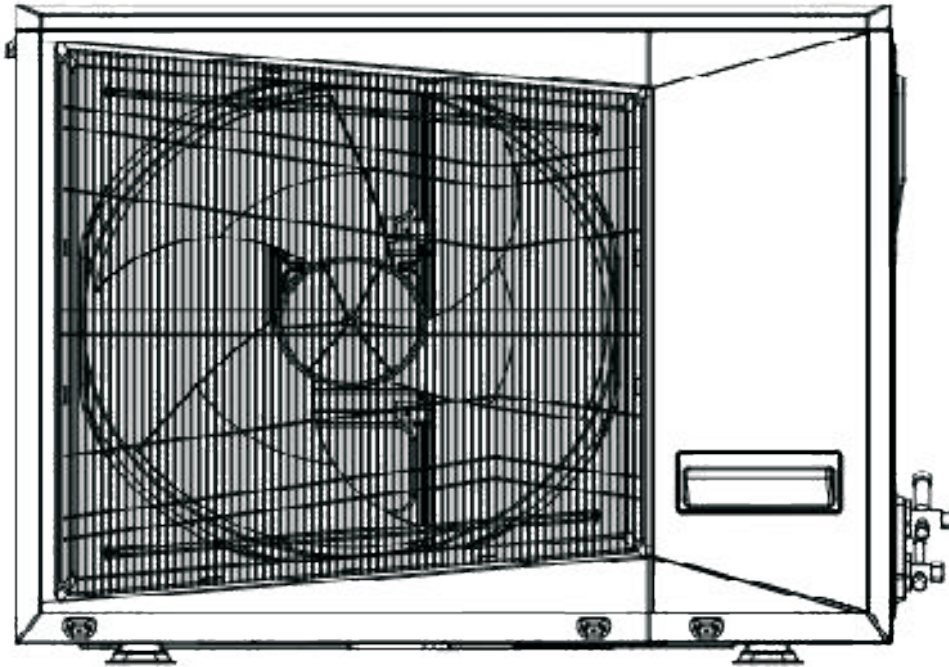

RECOGNIZE THIS SYMBOL AS A SAFETY PRECAUTION

ATTENTION INSTALLING PERSONNEL

Prior to installation, thoroughly familiarize yourself with this Installation Manual. Observe all safety warnings.

During installation or repair, caution is to be observed.

It is your responsibility to install the product safely and to educate the customer on its safe use.

Eair LLC
12201 N.W. 107 Avenue, Medley, FL 33178
www.comfortstarusa.com

Horizontal/Side Discharge Condensing Units: Installation, Operation and Maintenance



TABLE OF CONTENTS

Safety Precautions	3
General Operating Instructions.....	4
General Product Information	5
Outdoor Unit Installation.....	6-7
Unit Wiring.....	8-12
Wiring Diagrams	8-12
Refrigerant Piping.....	13
Leak Test, Evacuation & Release of Refrigerant.....	13
Initial Start-Up & Checks	14
Field Charging	14
Field Inspection	14

SAFETY PRECAUTIONS

- Please read this installation manual completely before installing the product.
- If the power cord is damaged, replacement work shall be performed by authorized personnel only.
- Installation work must be performed in accordance with all local and national codes by authorized personnel only.
- Contact an authorized service technician for repair, maintenance or installation of this unit.
- All the pictures in the instructions are for explanation purposes only, and may differ from the actual product you purchased.
- The design and specifications are subject to change without prior notice for product improvement. Consult with the sales agency or manufacturer for details.

- The seriousness of safety precautions is classified by the following indications:

 WARNING	This symbol indicates the possibility of death or serious injury.
 CAUTION	This symbol indicates the possibility of injury or damage to property.

WARNING

- 1) Install according to this installation instructions strictly. If installation is defective, it will cause water leakage, electrical shock fire, and may void the warranty.
- 2) Use the manufacturer's specified and supplied parts only.
- 3) Install in a strong and firm location which is able to withstand the unit's weight. If the strength is insufficient or installation is not properly done, the units can fall and cause injury.
- 4) For electrical work, follow all local and National electrical codes and these installation instructions. An independent circuit and single outlet must be used. If electrical circuit capacity is not enough or a defect found in electrical work, it may cause electrical shock or fire.
- 5) Use the specified cable, connect tightly and clamp the cable so that no external force will be acted on the terminal. If connection is loose, it may cause excessive heat build up.
- 6) Wiring routing must be properly arranged so that control board cover is fixed properly. If control board cover is not fixed perfectly, it will cause heat build up at connection point of terminal, fire or electrical shock.
- 7) When carrying out piping connection, take care not to let air substances other than the specified refrigerant go into refrigeration circuit. Otherwise, it will cause lower capacity, abnormal high pressure in the refrigeration cycle, explosion and injury.
- 8) Do not modify the length of the power supply cord or use an extension cord, and do not share the single outlet with other electrical appliances. Otherwise, it may cause fire or electrical shock.

CAUTION

- 1) This equipment must be properly grounded and installed with and ground leakage current breaker, otherwise it may cause electrical shock.
- 2) Do not install the unit in place where leakage of flammable gas may occur. If gas leaks and accumulates near or surroundings the unit, it may cause fire.
- 3) Carry out drainage piping as mentioned in installation instructions. If drainage is not properly done, water may enter the room and damage the furniture.

OPERATING INSTRUCTIONS

Air conditioners are designed to provide comfort cooling at outside temperatures above 65°F (18°C) but less than 109°F (43°C). Operating the air conditioner outside of this temperature range may cause unit failure and will void the warranty. If you have need for cooling at lower outdoor temperatures a “low ambient cooling” can be field installed. Contact your local contractor or call the factory.

TO OPERATE:

NOTE: *The thermostat operation may vary by type and model used. Please consult the operating manual that was provided with the thermostat. The instructions below are generalized for most standard thermostat models.*

1. Set the switch on your wall thermostat to the ‘cool’ position.
2. Set the desired temperature (between 63-86°F or 17-30°C) you want to maintain by moving the temperature setting on your thermostat. If the room is warmer than the setting, the unit will turn on and begin to blow cool air after a few minutes. A warm, humid room or building may take several hours of continuous operation to cool to the thermostat set point the first time. Once the set temperature is reached the unit will cycle on and off.
3. Set the ‘Fan’ switch on the thermostat to ‘auto’ if you want the fan to run only when cooling is needed or to ‘on’ if you want continuous air circulation. The ‘on’ setting of the fan generally provides better temperature control by eliminating stagnant air.

NOTE: *A properly installed and sized unit will not cycle more than 10 times per hour. If you notice more frequent starts call your service contractor.*

4. For energy conservation reasons, you may want to set your thermostat at a higher temperature when you are away. Do not raise the temperature setting by more than 5 degrees. Changing the temperature by more than 5 degrees or shutting the unit ‘off’ can actually cost more than leaving the setting at a constant temperature.

IMPORTANT

Wait at least 3 minutes after turning your air conditioner off before trying to restart it. This gives the unit the time needed to stabilize before restarting. Failure to do so may cause unit damage and failure.

MAINTENANCE:

Only simple periodic maintenance is required:

1. Change or clean the indoor unit air filter monthly or more frequently if unusual conditions are encountered. If you have a disposable type, throw the old one away and install a fresh one of the same size and type. If your unit has a washable type then vacuum and wash with soap and water. Flush thoroughly and dry before re-installing.
2. Keep the coil in the outdoor unit clean. Periodically flush the coil thoroughly with a garden hose. Clean away all foreign materials such as dust, leaves, grass clippings, papers, etc.

WARNING

Turn the power off first! Serious injury or death may result if water spray is directed at live electrical connections or power sources.

IMPORTANT!

Alterations and replacement parts:

Altering the product or replacing parts with non-authorized parts will void the factory Warranty and may result in adverse operational performance and/or a possible hazardous safety condition to service personnel and occupants. If you are in doubt as to how to service this unit or where to find factory replacement parts, call Heat Controller at (517) 787-2100 for assistance.

GENERAL PRODUCT INFORMATION

UNPACKING AND INSPECTION:

The condensing unit is shipped completely assembled and in its own package. All goods are inspected at the factory and released to the freight company in good condition. When received at the site, a visual inspection of all packages should be made immediately. Any evidence of rough handling or apparent damage should be noted on the delivery receipt and the material inspected in the presence of the carrier's representative. If damage is found a claim should be immediately file with the freight company.

COOLING OPERATION

TEMPERATURE LIMITS:

Heat Controller Condensing units are designed to operate in cooling at outside temperatures between 65°F (18°C) and 109°F (43°C). If the condensing unit will be used to cool at temperatures below 65°F (18°C), a low ambient control must be field installed. Operation below 65°F (18°C) without low ambient control will void the warranty.

INDOOR UNIT USE

AND SYSTEM EFFICIENCY:

Heat Controller condensing units are designed to be compatible with most major brands of domestic evaporator coils/air handlers. Imported ductless air handlers maybe used but often do not include an expansion device. A properly sized thermostatic expansion valve is recommended. Consult AHRI's directory of certified products for indoor matches.

THERMOSTAT AND INDOOR

FAN TIME DELAY:

All indoor units should include a fan time delay. This may be accomplished by using a digital wall thermostat or installation of a different fan time delay designed to work with your specific furnace/air handler. As follow:

MODEL	12	18	24	30	36	48
DELAY	115s	90s	90s	90s	100s	65s

Most brands of electronic thermostats include a fan delay. Properly specified thermostats are the responsibility of the installer. Proper temperature control and unit operation depends on proper thermostat selection and location. Refer to the thermostat manufacturer's installation instructions for specified recommendations. Good practice is to avoid outside walls, locations where the sun may shine directly on the thermostat, and locations where the air from supply registers or unit outlets blow on the thermostat. Also avoid locations where the thermostat could be jarred by a closing door or high traffic area.

WARNING: An in-line filter drier is required when the unit is installed. The filter drier is not provided by the factory, therefore a locally purchased filter drier must be used to remove any particulates or moisture that may be present in the system. Installations without an in-line filter drier may void the warranty.

OUTDOOR UNIT INSTALLATION

UNIT LOCATION AND MOUNTING:

Choose a location that places the condensing unit as close to the indoor unit as possible. The maximum unit separation and vertical lift (compressor above evaporator) must be taken into account [See Fig 1]. Do not exceed allowable pipe lengths.

Fig. 1

Refrigerant Piping		Model No.					
		COU-12	COU-18	COU-24	COU-30	COU-36	COU-48
Liquid-Gas	In.	1/4-1/2	3/8-5/8	3/8-3/4			
Max. Refrigerant Line Length*	Ft.	82					98
Max. Elevation Vertical Lift**	Ft.	33					49

*Minimum pipe length must not be less than 15 feet.

** "P" trap risers every 10 ft. when outdoor unit is installed above indoor unit.

NOTE: Oil traps must be installed every 10ft. when the outdoor unit is installed above the indoor unit.

Install the outdoor unit on a rigid surface, able to withstand the unit's weight, such as a concrete slab.

If the installation location allows the unit to be exposed to strong winds (such as sea side applications), ensure that the unit has a barrier from the wind [See Fig. 2]. This will assist with the proper operation of the fan by obstructing strong gusts of wind from entering the unit's cabinet.

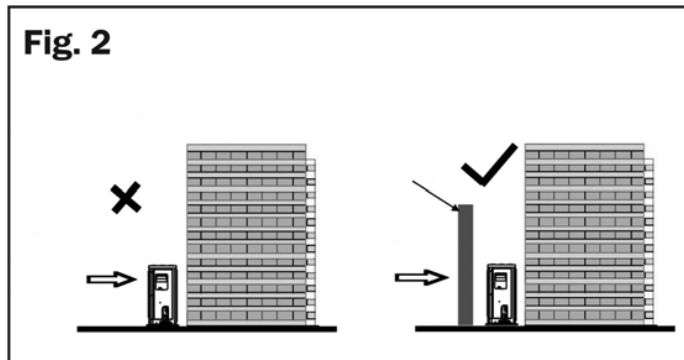

Avoid areas where water, snow, or ice may fall from a roof onto the unit. In climates where snow is a consideration, locate the unit away from areas prone to drifting. Ensure the location of the unit will not be subject to snow drifts, heavy accumulation of snow or leaves or other seasonal debris. If unavoidable, provide the awning for the unit.

An awning can be built over the outdoor unit to prevent direct sunlight or rain exposure or snowfall. Ensure that the awning is at least 2 ft. above the top of the unit's housing.

During heating and defrost modes, the condensate should be properly drained away from the unit.

Insure free flow of air into and out of the unit. Inlets/outlets should stay clear of obstructions such as walls and shrubs. Minimum clearances must be adhered to [See Fig. 4 & 5 on page 7].

Do not locate two or more units in a way that will block air flow or in a way that hot air from one unit will blow into a nearby unit [See Fig. 3].

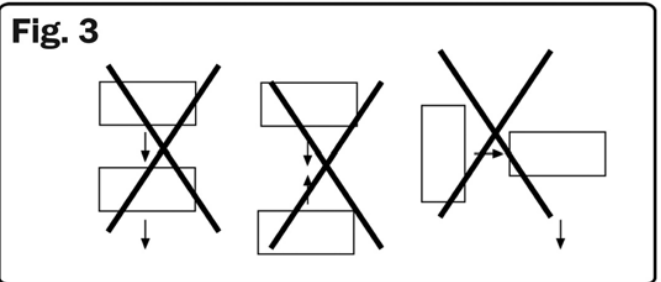

OUTDOOR UNIT INSTALLATION continued

Clearances

1. Ensure that there is sufficient clearance around the unit for installation and maintenance. Clearance must be maintained to ensure that the air inlets and outlets are not obstructed.

[See Fig. 4].

Anchor the outdoor unit with a 10mm (3/8 inch) diameter bolt and nut tightly on a concrete or rigid surface **[See Fig. 5]**. Anchoring is especially recommended in seaside/high wind applications and/or areas prone to earthquakes.

1. Split type outdoor unit clearances

Fig. 4

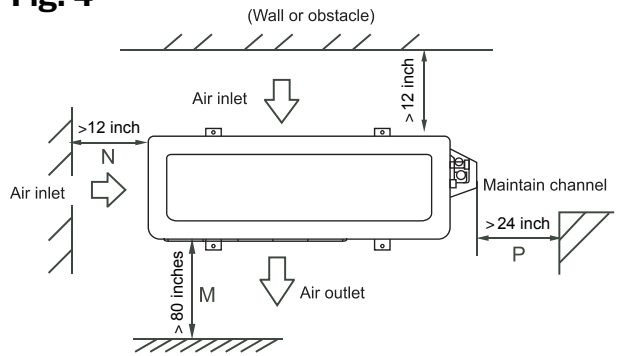

1. Split type outdoor unit dimensions

Applicable for 12-48

Fig. 5

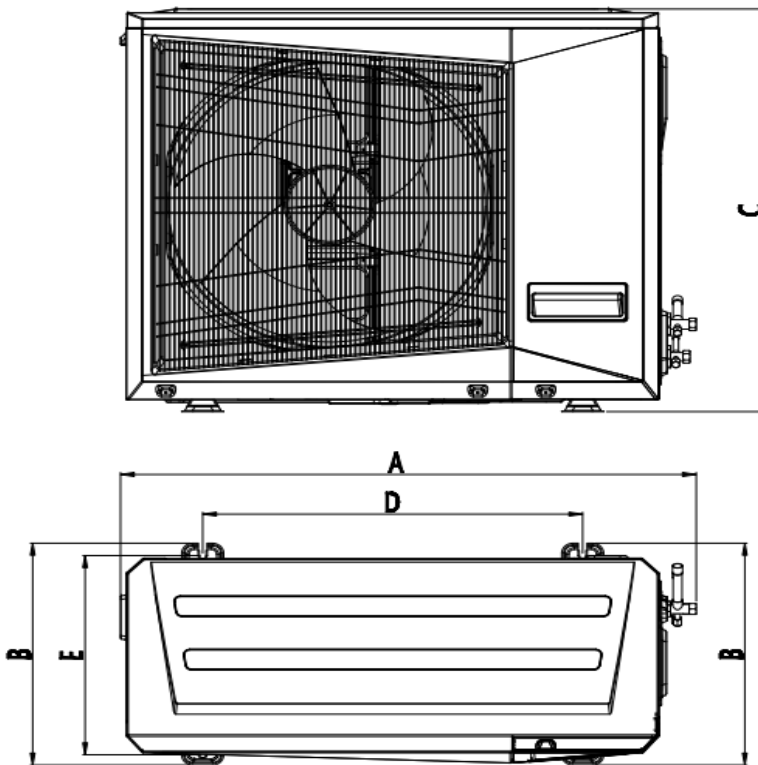

Units in inches

Model	A	B	C	D	E
12	33.5	13.6	21.9	20.0	11.0
18	36.0	15.0	27.6	21.4	12.8
24&30&36	40.0	17.5	31.9	26.4	15.2
48	43.3	20.8	34.3	25.0	17.4

UNIT WIRING

ELECTRICAL WIRING AND SUPPLY VOLTAGE:

All electrical wiring must be done according to NEC and local codes. Nameplate data indicates the operating voltage, phase, ampacity, maximum over current protection, and minimum voltage.

The contractor is to provide an individual branch circuit for over current protection for the unit as required by code. Run power supply wiring through a weatherproof disconnect box and conduit to the unit connection. Disconnects are required to be within sight and easy reach of the unit (usually within 3 feet).

Check the unit wiring diagram for the number of conductors required. Route neatly and protect from sharp edges and damage.

Inadequate wiring and/or improper electrical supply will likely result in failure of the compressor and other electrical components and voids the warranty.

NOTE: The supply voltage must be consistent with the rated voltage of the air conditioner, not to exceed +/- 10%. Ensure the unit is properly grounded.

Outdoor unit wiring connection

1. Remove the electrical control cover from the outdoor unit.
2. Connect the cables to the terminals as identified with their respective designated terminal spaces on the terminal block of indoor and outdoor units. 600V THHN 14 AWG/4 conductor unshielded stranded copper cable is recommended, however NEC/local codes prevail.
3. To prevent the entrance of water into outdoor unit, form a loop in the cable [See Fig. 6].
4. Insulate any unused conductors with PCV/ Electrical tape, so that they do not touch any other exposed electrical or metal parts.

CAUTION

Incorrect wiring connections may cause electrical parts to malfunction. All wiring must comply with local and national electrical codes and be installed by qualified and skilled electricians.

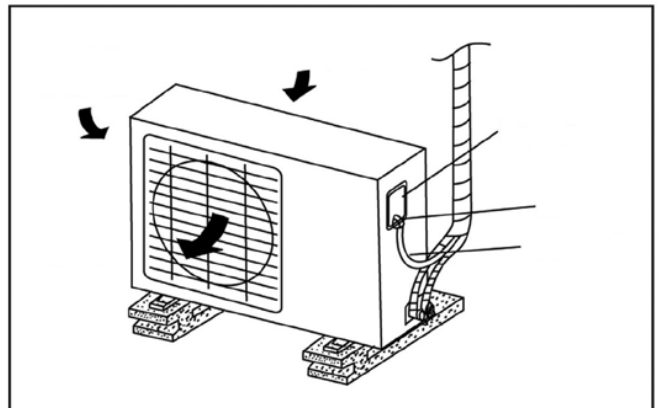

MODEL		12	18	24	30	36	48
POWER (outdoor)	PHASE	1PHASE	1PHASE	1PHASE	1PHASE	1PHASE	1PHASE
	VOLT	115V	208/230V	208/230V	208/230V	208/230V	208/230V
CIRCUIT BREAKER/FUSE(A)		15	15	15	20	25	40
MINIMUM CIRCUIT AMPACITY(A)		11	10	11.5	14	16	25.5

OUTDOOR UNIT WIRING CONNECTION continued

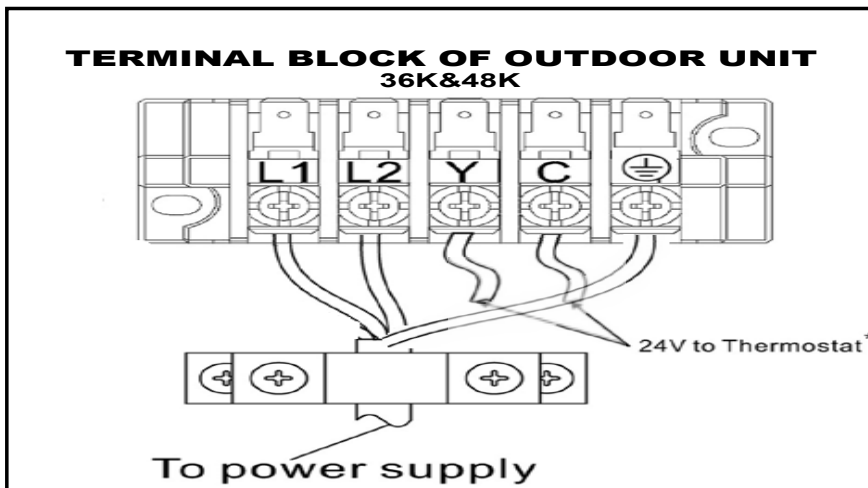
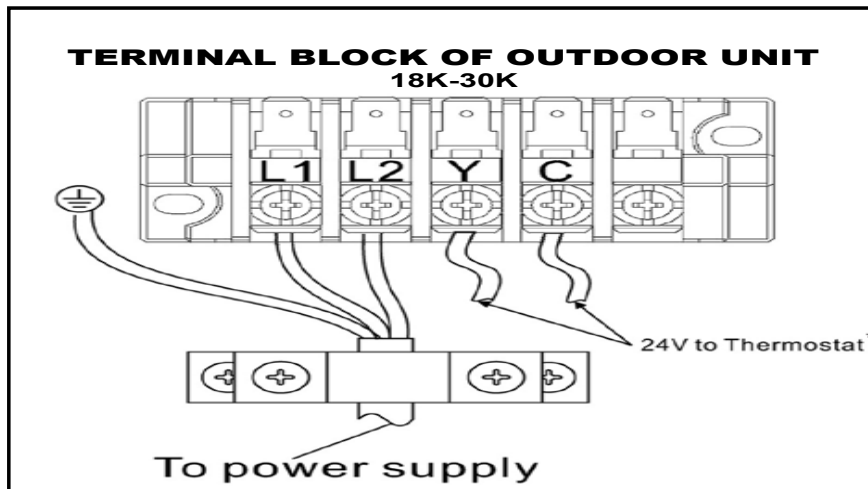
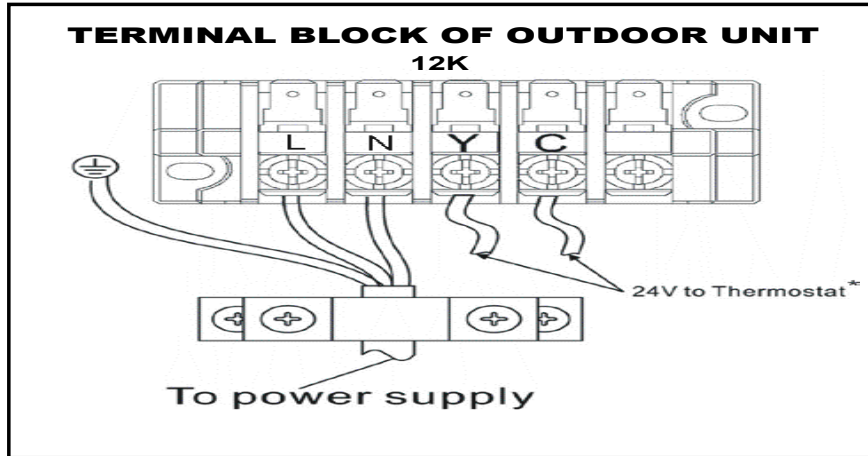

*NOTE1: Please refer to the installation instructions of the 24V thermostat used in conjunction with this unit for additional wiring instructions.

NOTE2: For reference only, the actual wiring diagram shall prevail

OUTDOOR UNIT WIRING CONNECTION continued

12K

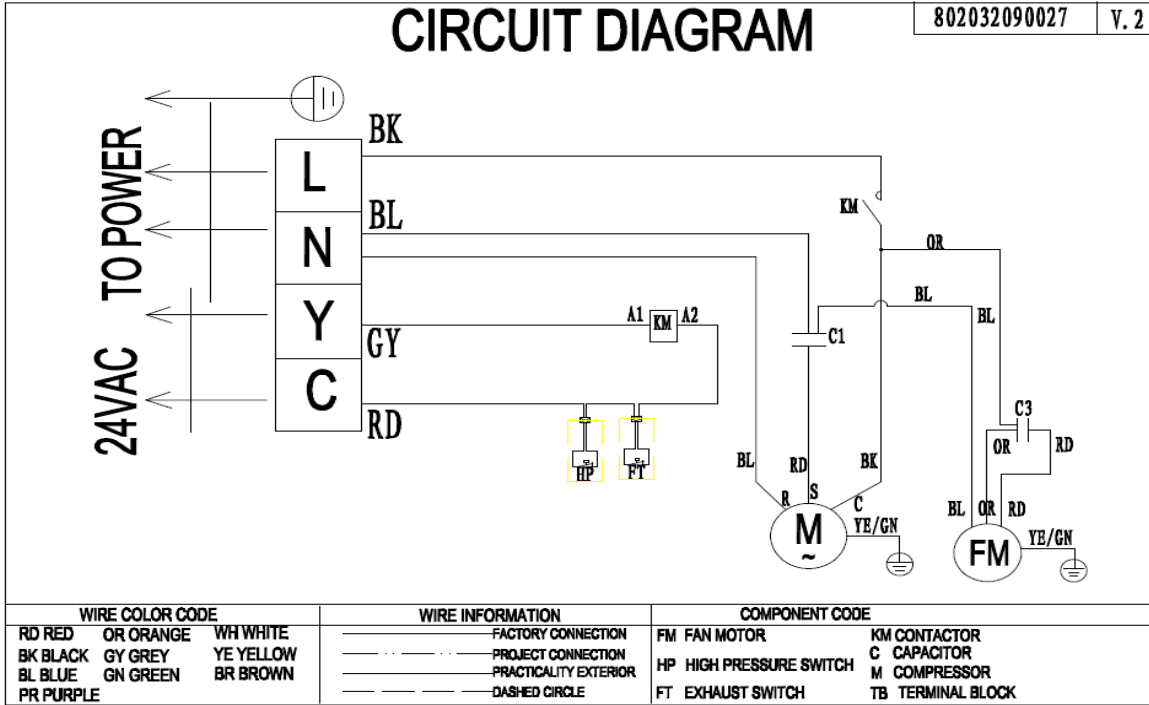

18K

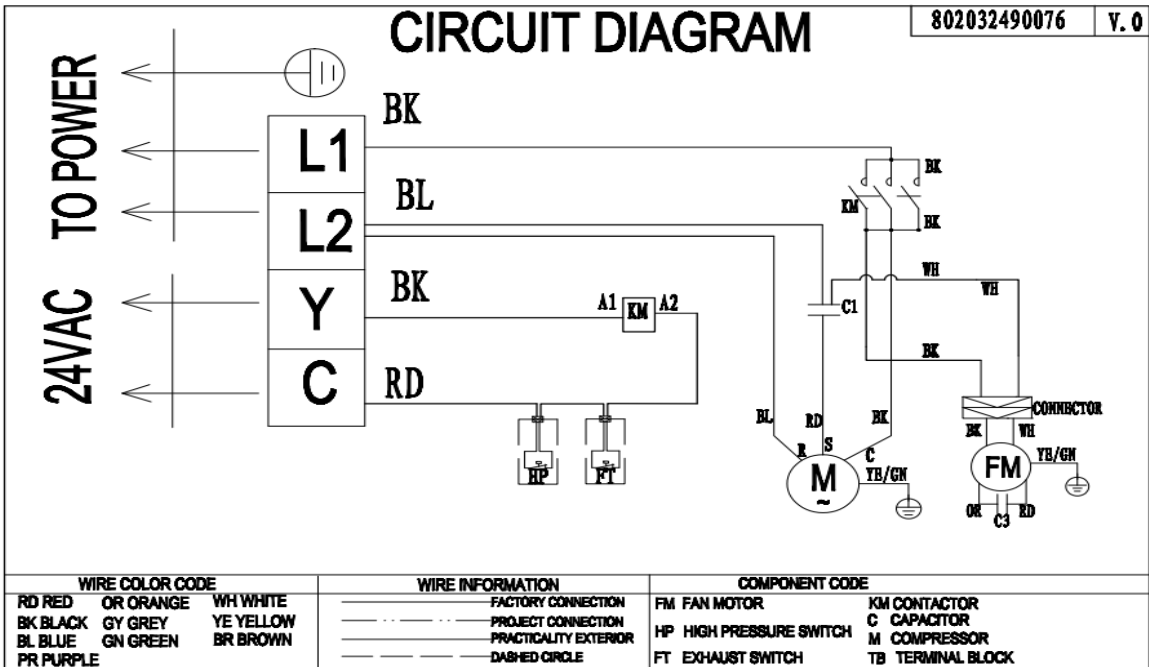

*NOTE: For reference only, the actual wiring diagram shall prevail

24K & 30K

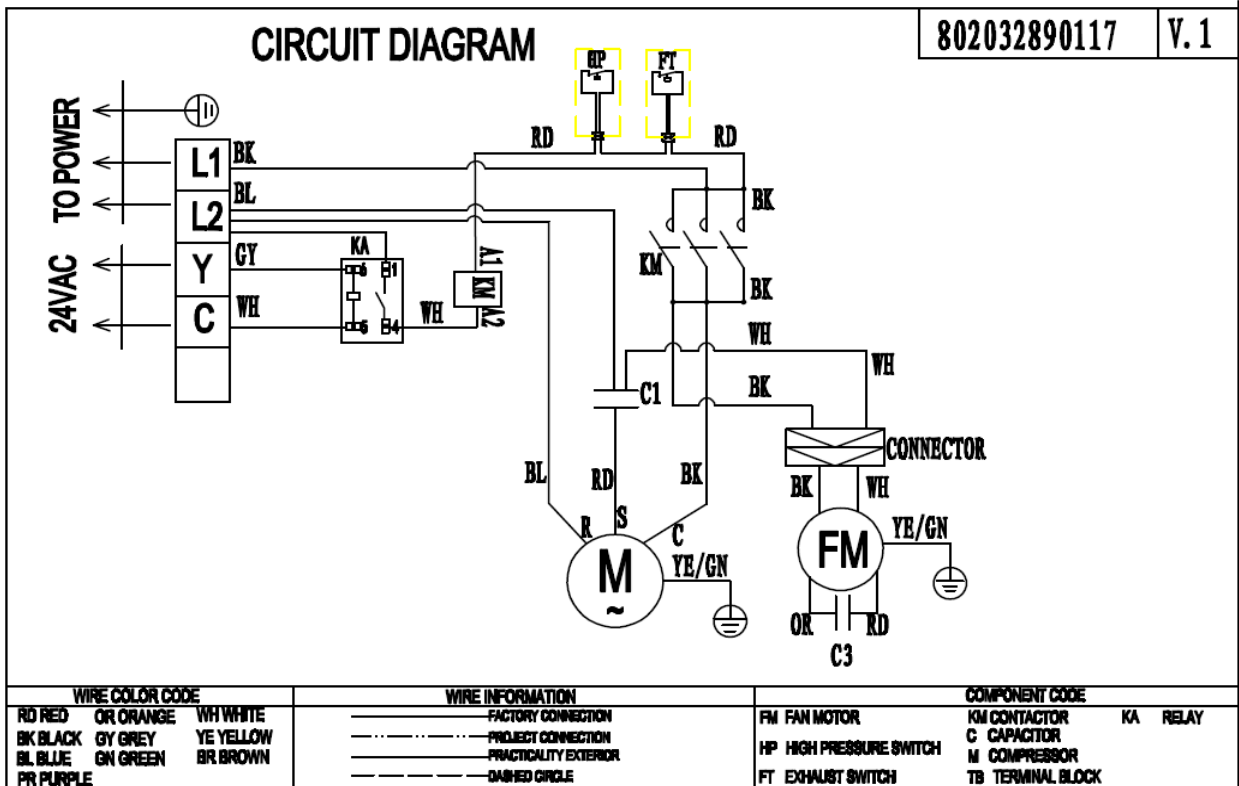

36K

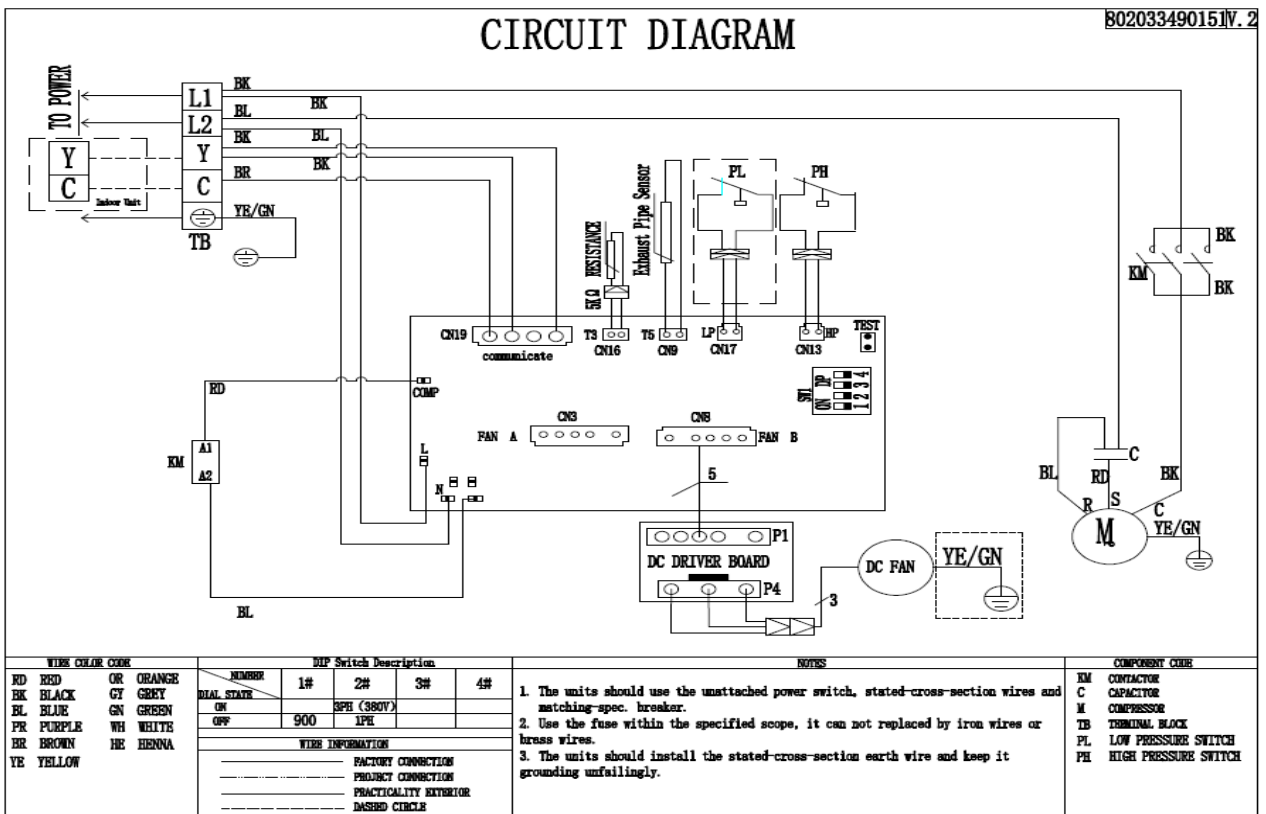

* **NOTE:** For reference only, the actual wiring diagram shall prevail

48K

CIRCUIT DIAGRAM

802034090122V.4

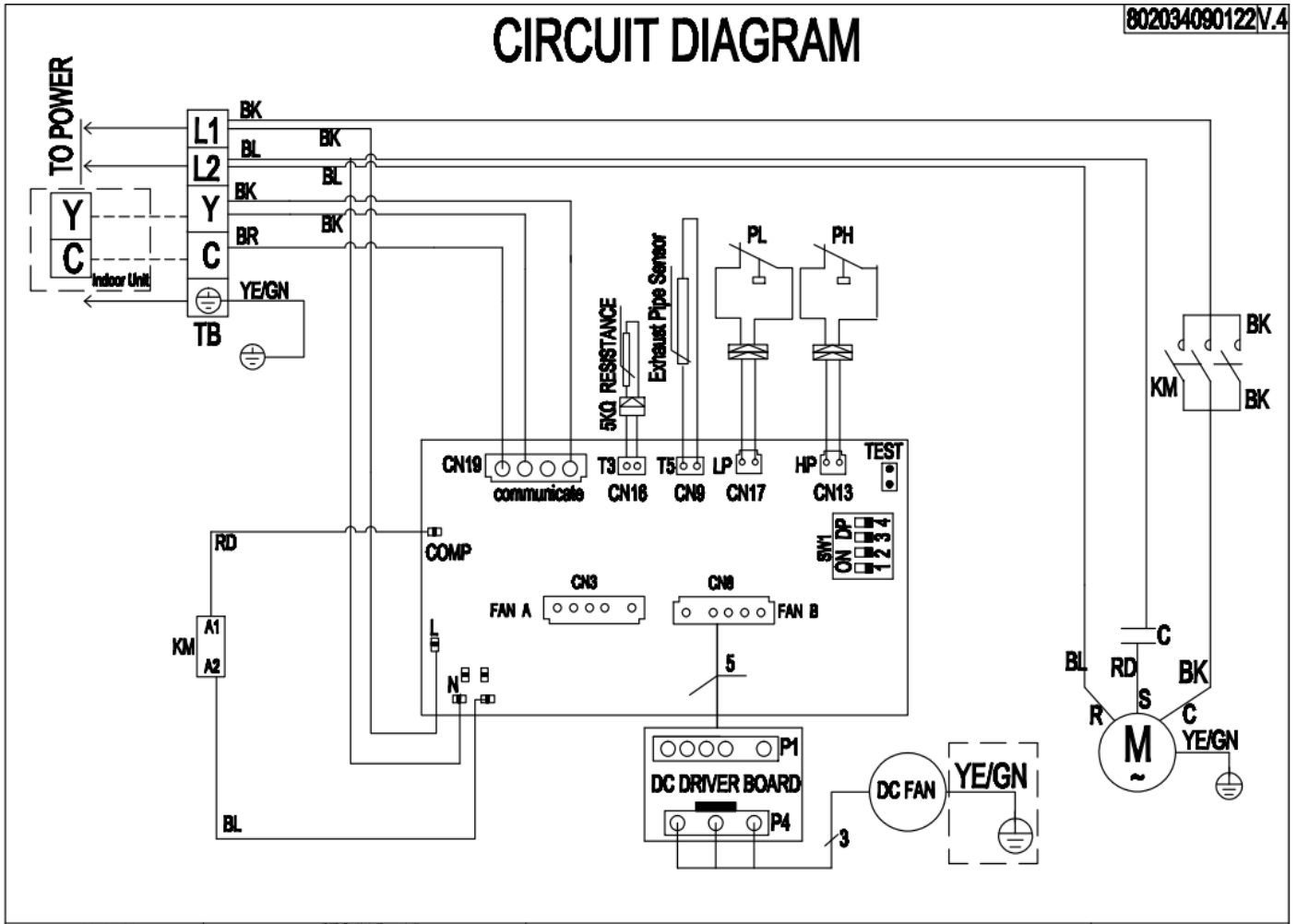

* NOTE: For reference only, the actual wiring diagram shall prevail

REFRIGERANT PIPING

The length of refrigerant lines and the number of bends determine the pressure drop which affects capacity and efficiency of the system and oil return to the compressor. The outdoor unit connections are braze type. Tube size should always be the same diameter as the connections provided at the service valves. Up sizing of lines can result in inadequate oil return to the compressor and excessive refrigerant charge and will void the warranty [See Table 1].

Refrigerant Piping		Model No.					
		COU-12	COU-18	COU-24	COU-30	COU-36	COU-48
Liquid-Gas	In.	1/4-1/2	3/8-5/8	3/8-3/4			
Max. Refrigerant Line Length*	Ft.	82					98
Max. Elevation Vertical Lift**	Ft.	33					49

*Minimum pipe length must not be less than 15 feet.

** "P" trap risers every 10 ft. when outdoor unit is installed above indoor unit.

Choose a location that places the condensing unit as close to the indoor unit as possible. The maximum separation is dependent on model. Use only clean refrigeration grade tubing. Avoid piping on wet or rainy days. Always keep the tube ends capped until you are ready to make the final connections. Remove burrs from cut ends of tubing. Use tube benders to avoid kinking.

Insulate the suction line with Armaflex or equivalent with a wall thickness of at least 3/8". Support the tubing adequately to avoid sags that can trap oil. Isolate the tubing so as not to transmit noise to the building structure. Avoid sharp edges that could cut the tubes. Maximum vertical lift (compressor above evaporator) is dependent on model. Trap risers with a 'P' trap every 10 feet.

WARNING

It is illegal to discharge refrigerant into the atmosphere. Use proper reclaiming methods and equipment when working on the refrigerant containing parts of the unit. Service should be performed by a QUALIFIED service agency and certified technicians.

LEAK TEST, EVACUATION & RELEASE OF REFRIGERANT

The condensing unit is supplied with R-410a charge sufficient for most matching evaporator units. Charge must be added for interconnecting tubing.

The unit's service valves are shipped in the closed position and should not be opened until final connections and evacuation are completed.

The recommended procedure for leak test, evacuation, and release of refrigerant is outlined below:

1. Complete the final piping connections to the indoor and outdoor units using high temperature brazing alloy.
2. Connect a charging manifold to the service ports provided at the service valves.
3. Pressurize the lines and evaporator with nitrogen and leak check all connections with soap bubbles. Repair as necessary any faulty joints. If brazing is required be sure to **RELEASE THE NITROGEN FIRST**. Re-test as needed.
4. Connect a vacuum pump to the manifold center connection, start the pump and open the manifold valves.
5. Evacuate to 500 microns or less for a minimum of 30 minutes. Close the manifold valves and shut off the pump. Note the vacuum reading and wait 15 minutes. Take a new vacuum reading. A reading of 800 microns or higher indicates the presence of moisture or a leak.
6. Repair as necessary and repeat steps 3, 4 & 5.
7. Confirm that manifold valves are closed and disconnect the vacuum pump.
8. Remove the caps from the services valves. Open the valves to the fully 'back-seat' position. Replace service valve caps and tighten.

INITIAL START-UP & CHECKS

Operation of the unit is automatic and will provide cooling depending on the setting of the thermostat.

IMPORTANT!

All panels must be installed, main power turned on and the thermostat properly connected before operating the unit.

1. System check - set thermostat system switch to "Off" position and fan switch to "Auto" position. Turn the power supply breaker on.
2. Set the fan switch to "On," blower should operate.
3. Return the fan switch to "Auto". Blower should shut off. Set the system switch to "Cool" and lower thermostat set point to coldest setting. The compressor, condenser fan, and evaporator blower should all come on. Cool air will be supplied after a couple of minutes of run time.
4. Proceed to the "FIELD CHARGING" section of these instructions.

FIELD CHARGING

Unit performance, efficiency, and life depends, to a large extent, on a proper system charge. Time spent on getting the charge right at start-up will payoff in the long run. Operating conditions such as voltage, air flow, evaporator coil size, and indoor and outdoor temperature and humidity all have an effect on the system pressures and superheat conditions.

Charge must be added for the interconnecting tubing. Evaporator coils require thermostatic expansion valves. These units should be critically charged to ensure proper performance. Some systems may require additional charging of refrigerant, depending on line set lengths.

FINAL INSPECTION

Do a final visual inspection of the entire installation and complete any final details and clean up.

Review Unit Operation with the homeowner/user.

The pressure/temperature chart can be used as a reference to ensure performance.

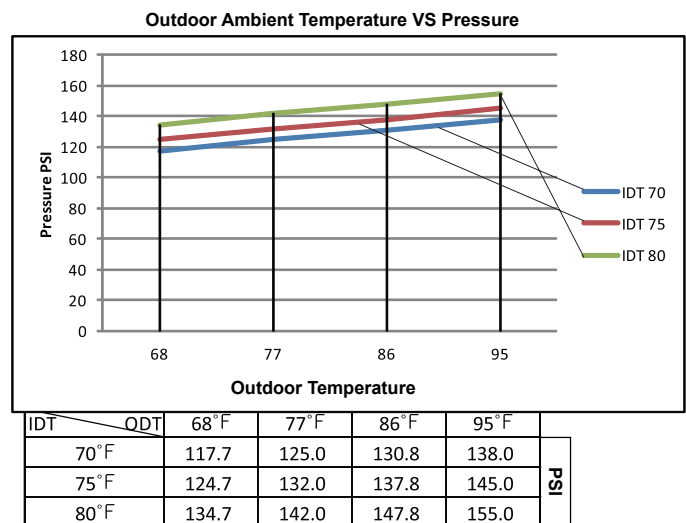

Note: "IDT" = Indoor Temperature
"ODT" = Outdoor Temperature

1. Remove refrigerant, if the pressure is above the chart value.
2. Add refrigerant, if the pressure is below the chart value.

$$R = T \times (L-25)\text{ft}$$

R(oz): Additional refrigerant to be charged
L(ft): The length of the liquid pipe
T(oz): The quantity of the charged refrigerant per additional foot

MODEL	12	18	24	30	36	48
oz/ft	0.16		0.32			

ComfortStar®

**Design, material, performance specifications and components
subject to change without notice.**