

Revision V2201

Table of Contents

1. Precaution
2. Part Names And Functions
3. Dimension
4. Service space
5. Refrigerant Cycle Diagram
6. Wiring Diagram
7. Fan Curves
8. Air Velocity Distributions
9. Electric Characteristics
10. Sound Level
11. Accessories
12. The Specification of Power
13. Field Wiring
14. Installation Details
15. Operation Characteristics
16. Electronic Function
17. Troubleshooting
18. Disassembly Instructions

Model Numbers:

Regular ODU	HI HEAT ODU	Ducted	Floor Ceiling	Cassette
CZP09CD(O)	CHF09CD(O)	CPA-09B		TPA-09
CZP12CD(O)	CHF12CD(O)	CPA-12B		TPA-12
CZP18CD(O)	CHF18CD(O)	CPA-18B	FPA-18	TPA-18
CZP24CD(O)	CHF24CD(O)	CPA-24B	FPA-24	TIP24
CZP36CD(O)	CHF36CD(O)	CPA-36DUB	FPA-36DU	TIP36
CZP48CD(O)	CHF48CD(O)	CPA-48DUB	FPA-48DU	TIP48
CZP60CD(O)		CPA-60DU	FPA-60DU	

WARNING

- Installation MUST conform with local building codes or, in the absence of local codes, with the National Electrical Code NFPA70/ANSI C1-1993 or current edition and Canadian Electrical Code Part1 CSA C.22.1.
- The information contained in the manual is intended for use by a qualified service technician familiar with safety procedures and equipped with the proper tools and test instruments
- Installation or repairs made by unqualified persons can result in hazards to you and others.
- Failure to carefully read and follow all instructions in this manual can result in equipment malfunction, property damage, personal injury and/or death.
- This service is only for service engineer to use.



CONTENTS

1. Precaution	1
1.1 Safety Precaution	1
1.2 Warning	1
2. Part Names and Features	4
2.1 Model Names of Indoor/Outdoor units.....	4
2.2 Part names of Indoor/Outdoor units.....	5
2.3 Features	10
3. Dimension	19
3.1 Indoor Unit.....	20
3.2 Outdoor Unit	29
4. Service Space	34
4.1 Indoor Unit.....	34
4.2 Outdoor Unit	37
5. Refrigerant Cycle Diagram	38
6. Wiring Diagram	42
6.1 Indoor Unit.....	42
6.2 Outdoor Unit	70
7. Fan Curves	84
8. Air Velocity Distributions	93
9. Electric Characteristics	138
10. Sound Level	138
10.1 Indoor unit	138
10.2 Outdoor unit.....	141
11. Accessories	141
12. The Specification of Power	144
13. Field Wiring	145
14. Installation Details	147
14.1 Location selection.....	147
14.2 Indoor unit installation.....	147
14.3 Outdoor unit installation.....	158
14.4 Refrigerant pipe installation	159
14.5 Drainage pipe installation	164
14.6 Vacuum Drying and Leakage Checking.....	166
14.7 Additional refrigerant charge.....	167
14.8 Engineering of insulation	168
14.9 Engineering of electrical wiring	169
14.10 Test operation	169
15. Operation Characteristics	171

16. Electronic Function	172
16.1 Abbreviation.....	172
16.2 Display function	172
16.3 Main Protection.....	172
16.4 Operation Modes and Functions.....	174
17. Troubleshooting.....	185
17.1 Indoor Unit Error Display	186
17.2 Error Display on Two Way Communication Wired Controller.....	188
17.3 Outdoor unit error display	189
For 9K-24K outdoor unit:	189
For 36K-60K Outdoor Unit.....	190
Outdoor check function.....	191
17.4 Diagnosis and Solution.....	194
17.5 Main parts check	233
18. Disassembly Instructions	243
18.1 Indoor unit	243

1. Precaution

1.1 Safety Precaution

- To prevent injury to the user or other people and property damage, the following instructions must be followed.
- Incorrect operation due to ignoring instruction will cause harm or damage.
- Before service the unit, be sure to read this service manual at first.

1.2 Warning

➤ Installation

- Do not use a defective or underrated circuit breaker. Use this appliance on a dedicated circuit.

There is risk of fire or electric shock.

- For electrical work, contact the dealer, seller, a qualified electrician, or an authorized service center.

Do not disassemble or repair the product, there is risk of fire or electric shock.

- Always ground the product.

There is risk of fire or electric shock.

- Install the panel and the cover of control box securely.

There is risk of fire of electric shock.

- Always install a dedicated circuit and breaker.

Improper wiring or installation may cause electric shock.

- Use the correctly rated breaker of fuse.

There is risk of fire or electric shock.

- Do not modify or extend the power cable.

There is risk of fire or electric shock.

- Do not install, remove, or reinstall the unit by yourself (customer).

There is risk of fire, electric shock, explosion, or injury.

- Be caution when unpacking and installing the product.

Sharp edges could cause injury, be especially careful of the case edges and the fins on the condenser and evaporator.

- For installation, always contact the dealer or an authorized service center.

- Do not install the product on a defective installation stand.

- Be sure the installation area does not deteriorate with age.

If the base collapses, the air conditioner could fall with it, causing property damage, product failure, and personal injury.

- Do not let the air conditioner run for a long time when the humidity is very high and a door or a window is left open.

- Take care to ensure that power cable could not be pulled out or damaged during operation.

There is risk of fire or electric shock.

- Do not place anything on the power cable.

There is risk of fire or electric shock.

- Do not plug or unplug the power supply plug during operation.

There is risk of fire or electric shock.

- Do not touch (operation) the product with wet hands.

- Do not place a heater or other appliance near the power cable.

There is risk of fire and electric shock.

- Do not allow water to run into electrical parts.

It may cause fire, failure of the product, or electric shock.

- Do not store or use flammable gas or combustible near the product.

There is risk of fire or failure of product.

- Do not use the product in a tightly closed space for a long time.

Oxygen deficiency could occur.

- When flammable gas leaks, turn off the gas and open a window for ventilation before turn the product on.

- **If strange sounds or smoke comes from product, turn the breaker off or disconnect the power supply cable.**

There is risk of electric shock or fire.

- **Stop operation and close the window in storm or hurricane. If possible, remove the product from the window before the hurricane arrives.**

There is risk of property damage, failure of product, or electric shock.

- **Do not open the inlet grill of the product during operation. (Do not touch the electrostatic filter, if the unit is so equipped.)**

There is risk of physical injury, electric shock, or product failure.

- **When the product is soaked, contact an authorized service center.**

There is risk of fire or electric shock.

- **Be caution that water could not enter the product.**

There is risk of fire, electric shock, or product damage.

- **Ventilate the product from time to time when operating it together with a stove etc.**

There is risk of fire or electric shock.

- **Turn the main power off when cleaning or maintaining the product.**

There is risk of electric shock.

- **When the product is not be used for a long time, disconnect the power supply plug or turn off the breaker.**

There is risk of product damage or failure, or unintended operation.

- **Take care to ensure that nobody could step on or fall onto the outdoor unit.**

This could result in personal injury and product damage.

➤ CAUTION

- **Always check for gas (refrigerant) leakage after installation or repair of product.**

Low refrigerant levels may cause failure of product.

- **Install the drain hose to ensure that water is drained away properly.**

A bad connection may cause water leakage.

- **Keep level even when installing the product.**

It can avoid vibration of water leakage.

- **Do not install the product where the noise or hot air from the outdoor unit could damage the neighborhoods.**

It may cause a problem for your neighbors.

- **Use two or more people to lift and transport the product.**

- **Do not install the product where it will be exposed to sea wind (salt spray) directly.**

It may cause corrosion on the product.

Corrosion, particularly on the condenser and evaporator fins, could cause product malfunction or inefficient operation.

➤ Operational

- **Do not expose the skin directly to cool air for long time. (Do not sit in the draft).**

- **Do not use the product for special purposes, such as preserving foods, works of art etc. It is a consumer air conditioner, not a precision refrigerant system.**

There is risk of damage or loss of property.

- **Do not block the inlet or outlet of air flow.**

- **Use a soft cloth to clean. Do not use harsh detergents, solvents, etc.**

There is risk of fire, electric shock, or damage to the plastic parts of the product.

- **Do not touch the metal parts of the product when removing the air filter. They are very sharp.**

- **Do not step on or put anything on the product. (outdoor units)**

- **Always insert the filter securely. Clean the filter every two weeks or more often if necessary.**

A dirty filter reduces the efficiency of the air conditioner and could cause product malfunction or damage.

■ **Do not insert hands or other objects through air inlet or outlet while the product is operated.**

■ **Do not drink the water drained from the product.**

■ **Use a firm stool or ladder when cleaning or maintaining the product.**

Be careful and avoid personal injury.

■ **Replace the all batteries in the remote control with new ones of the same type. Do not mix old and new batteries or different types of batteries.**

There is risk of fire or explosion.

■ **Do not recharge or disassemble the batteries. Do not dispose of batteries in a fire.**

They may burn or explode.

■ **If the liquid from the batteries gets onto your skin or clothes, wash it well with clean water. Do not use the remote if the batteries have leaked.**

2. Part Names and Features

2.1 Model Names of Indoor/Outdoor units

Regular ODU	HI HEAT ODU	Ducted	Floor Ceiling	Cassette
CZP09CD(O)	CHF09CD(O)	CPA-09B		TPA-09
CZP12CD(O)	CHF12CD(O)	CPA-12B		TPA-12
CZP18CD(O)	CHF18CD(O)	CPA-18B	FPA-18	TPA-18
CZP24CD(O)	CHF24CD(O)	CPA-24B	FPA-24	TIP24
CZP36CD(O)	CHF36CD(O)	CPA-36DUB	FPA-36DU	TIP36
CZP48CD(O)	CHF48CD(O)	CPA-48DUB	FPA-48DU	TIP48
CZP60CD(O)		CPA-60DU	FPA-60DU	

2.2 Part names of Indoor/Outdoor units

Cassette Units

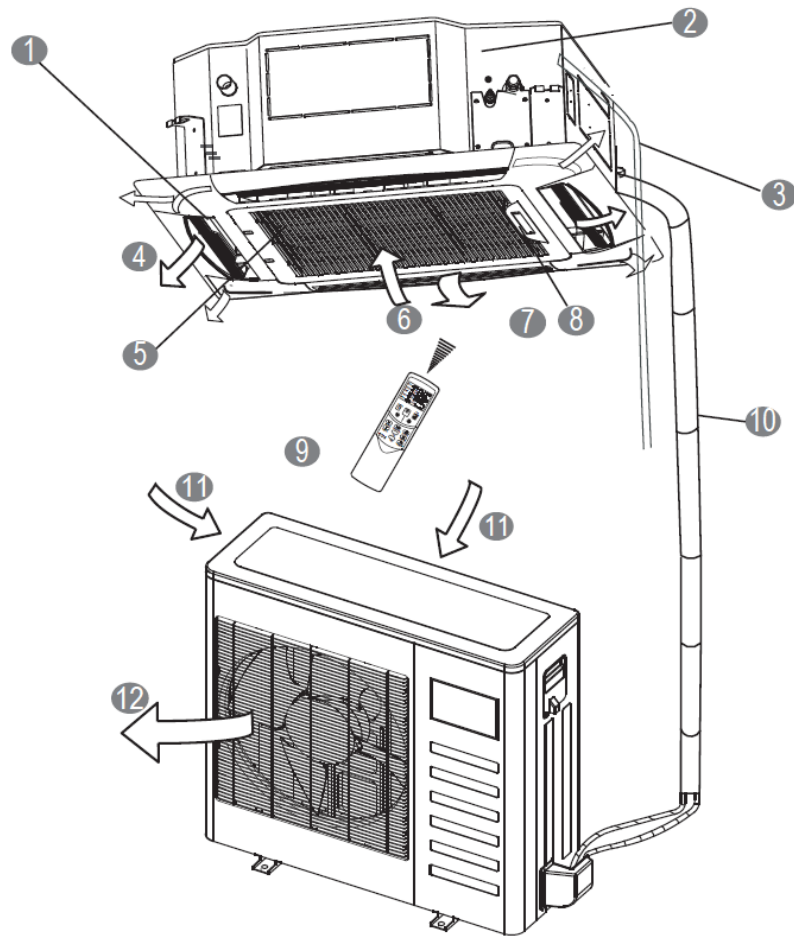

- | | | | |
|---|--|---|-------------------|
| ① | Air flow louver(at air outlet) | ⑦ | Air-in grill |
| ② | Drain pump(drain water from indoor unit) | ⑧ | Display panel |
| ③ | Drain pipe | ⑨ | Remote controller |
| ④ | Air outlet | ⑩ | Refrigerant pipe |
| ⑤ | Air filter(inside air-in grill) | ⑪ | Air inlet |
| ⑥ | Air inlet | ⑫ | Air outlet |

New Cassette Units

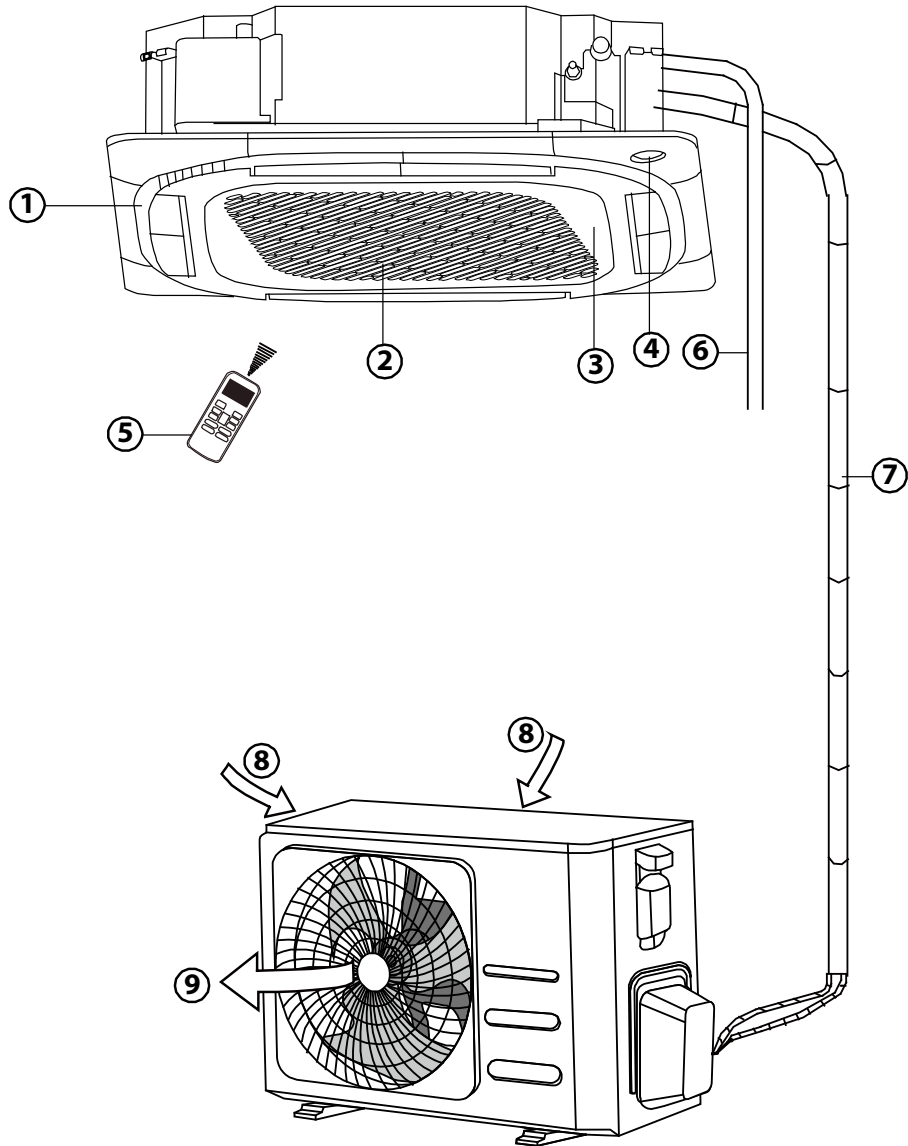

- ① Air outlet
- ② Air inlet
- ③ Front grille
- ④ Display panel
- ⑤ Remote controller
- ⑥ Drain pipe

- ⑦ Connecting pipe
- ⑧ Air inlet
- ⑨ Air outlet

FPA Duct Units

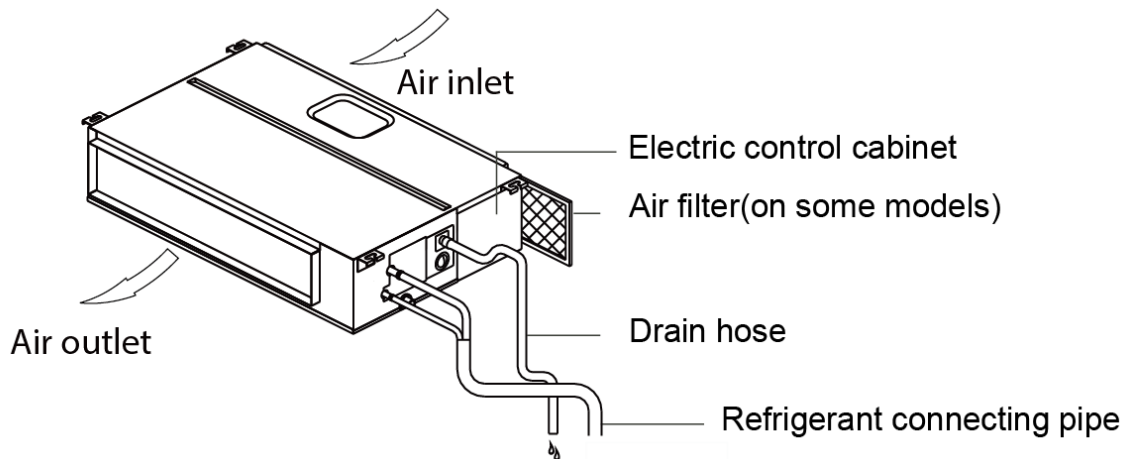

Console Units

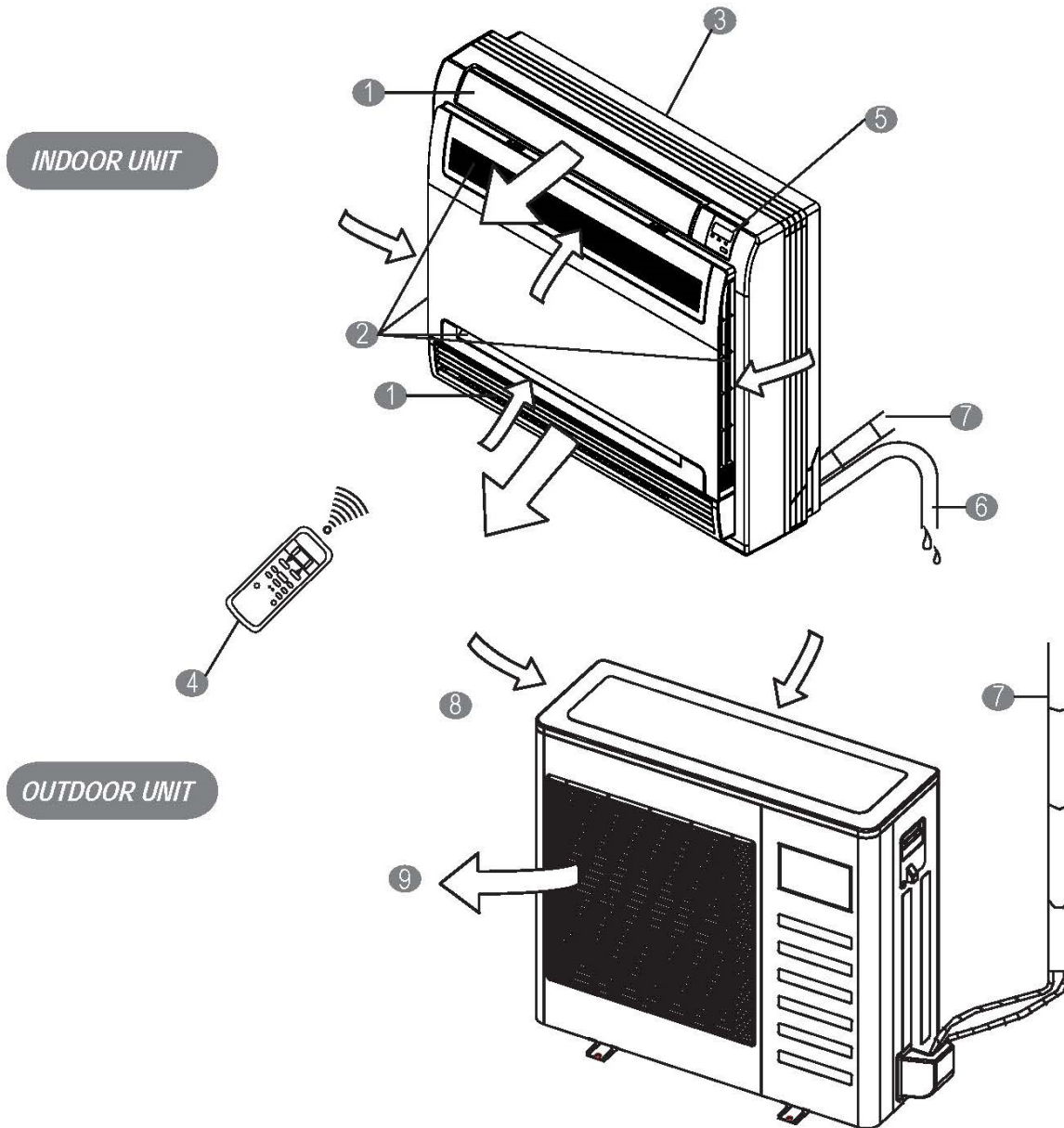

Fig.1

INDOOR UNIT

- ① Air flow louver (at air outlet)
- ② Air inlet (with air filter in it)
- ③ Installation part
- ④ Remote controller
- ⑤ Display panel
- ⑥ Drain pipe

OUTDOOR UNIT

- ⑦ Connecting pipe
- ⑧ Air inlet
- ⑨ Air outlet

Ceiling-floor Units

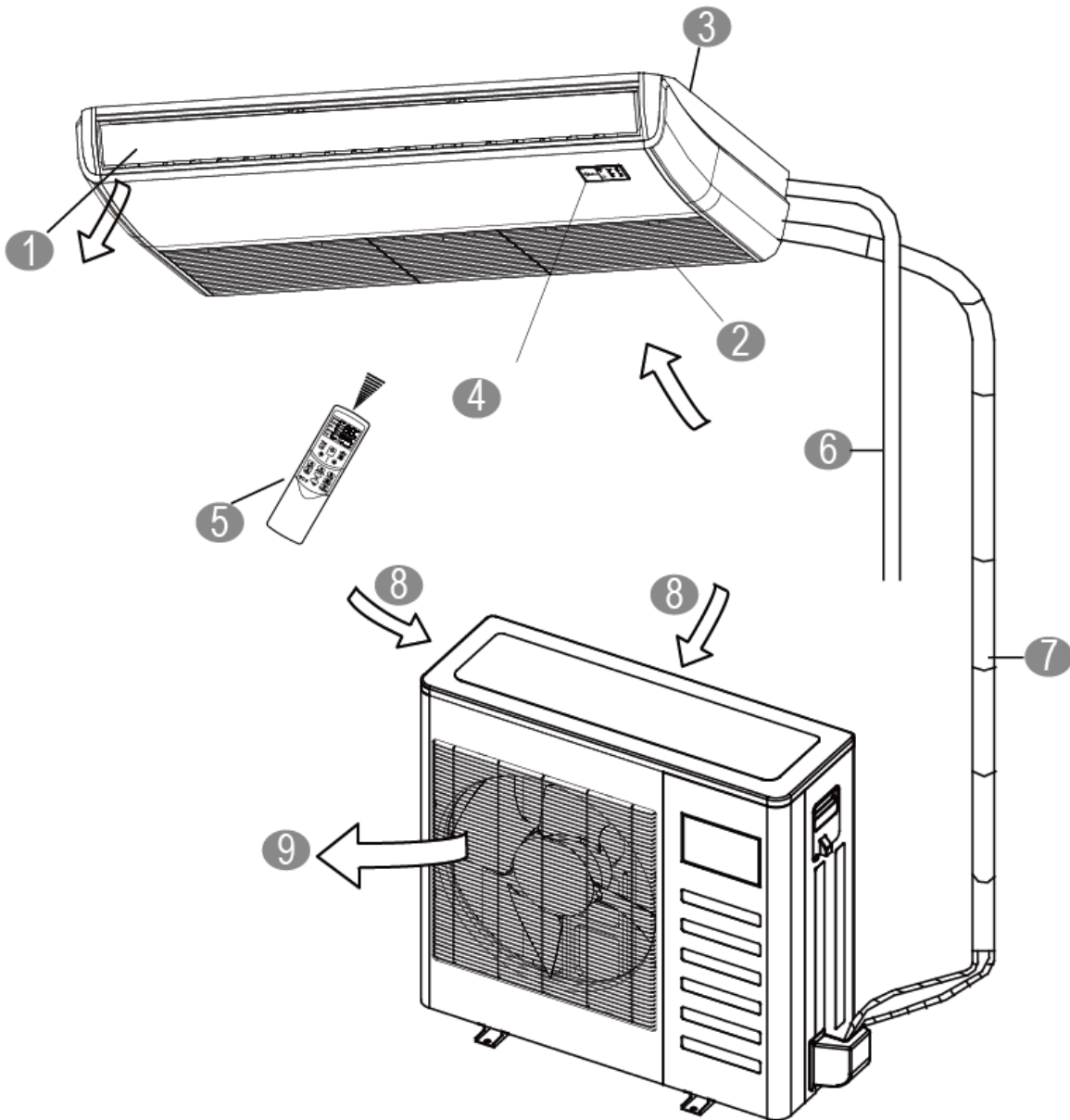

INDOOR UNIT

- ① Air flow louver (at air outlet)
- ② Air inlet (with air filter in it)
- ③ Installation part
- ④ Display panel
- ⑤ Remote controller
- ⑥ Drain pipe

OUTDOOR UNIT

- ⑦ Connecting pipe
- ⑧ Air inlet
- ⑨ Air outlet

HESP DUCT Units

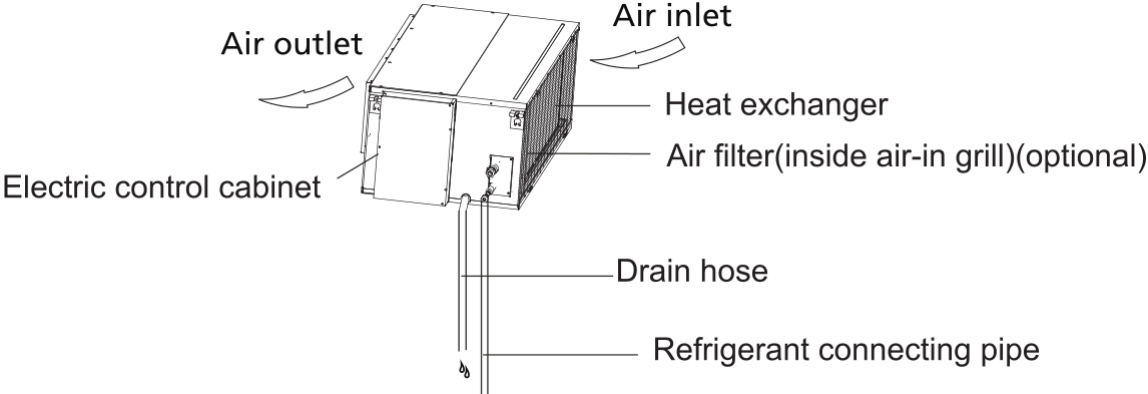

2.3 Features

2.3.1 Cassette Units

2.3.1.1 Lower Noise

- Optimize air channel system design to ensure the maximum quietness and comfort.
- Noise max down 6dB.

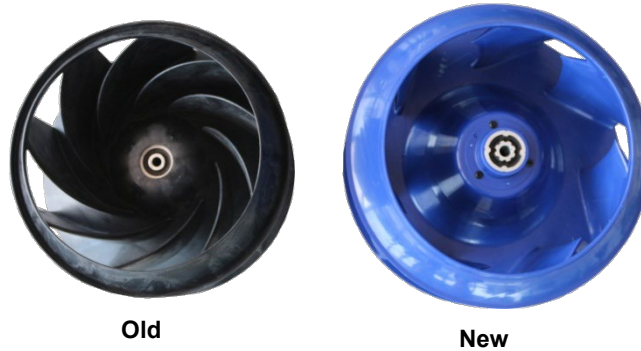

2.3.1.2 Turbo Mode (Optional)

- Turbo function can boost cooling or heating speed in a short period, and makes the room cool down or heat up rapidly.

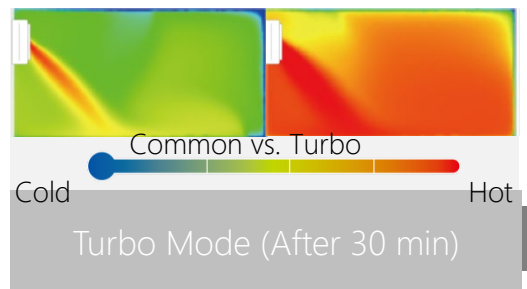

2.3.1.3 Fire-proof Controller Box

- Electrical control box adopts new design, which can meet higher fire safety requirements.

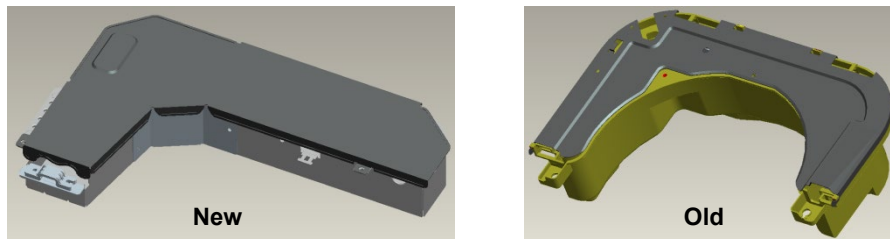

2.3.1.4 Fresh Air

- Fresh air intake function bring you fresh and comfortable air feeling.

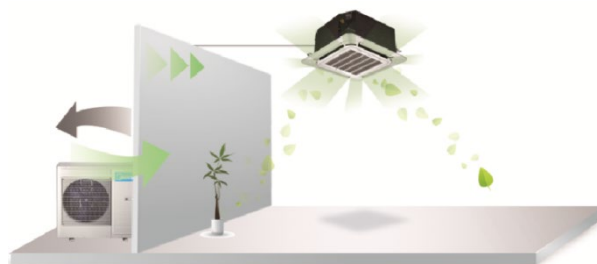

2.3.1.5 Wired Controller (Optional)

- Compared with infrared remote controller, wired controller can be fixed on the wall and avoid mislaying. It's mainly used for commercial zone and makes air conditioner control more convenient.



2.3.1.6 Build-in Drain Pump

- The drain pump can lift the condensing water up to 750mm upmost.
- It's convenient to install drainage piping under most space condition.

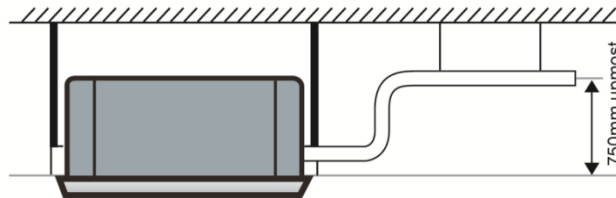

2.3.1.7 Terminals For Alarm Lamp and Long-distance On-off Controller Connection Are Standard

- Reserve terminals for the connection of alarm lamp and long-distance on-off controller, more human control.

2.3.2 Console Units (not for USA market)

2.3.2.1. Modern and Elegant Appearance

- The simple and stylish designs can nicely harmonies with your living space.



2.3.2.2. Two Air-outlet Ways

Cooling mode

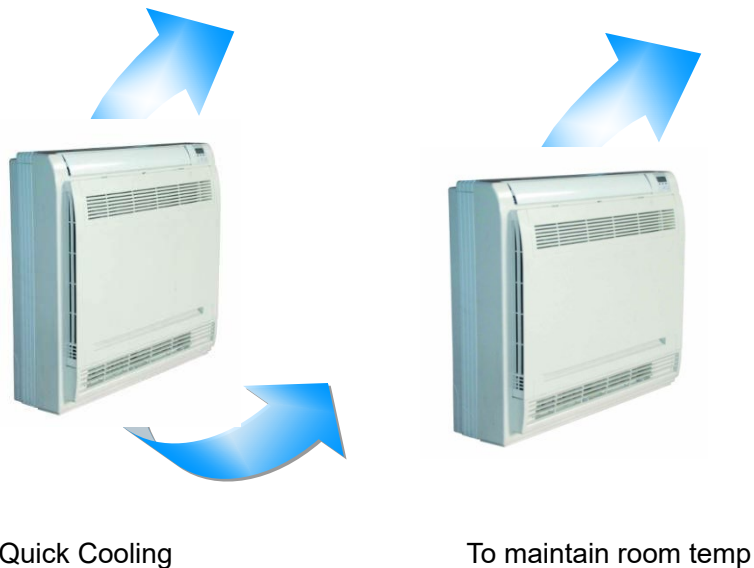

- Air outlet from top and bottom to make quick cooling -----When the A/C is just switched on, or room temp. is still high, cold air will be blown out from top and bottom air outlet to cool down the room quickly
- Air outlet from top to maintain room temp. ----When the room has been cooled down, or the A/C has been opened over 1 hour, cold air only from the top outlet to keep constant room temp

Heating mode

- Anti-cold air -----When the AC is just turn on, temperature of evaporator is very low, in this case, in order to prevent cold air direct blowing, only the upper louver is opened in a high position, the lower louver closed.



2.3.2.3. Four Air Inlets

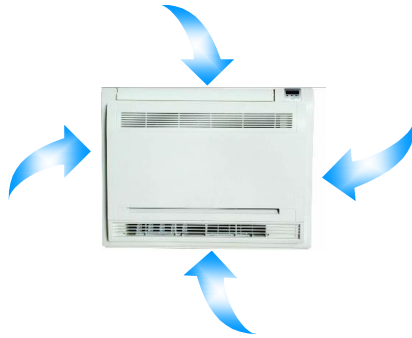

2.3.2.4. Low Noise

- DC indoor fan motor, which has five speeds.
- Low noise and energy saving.

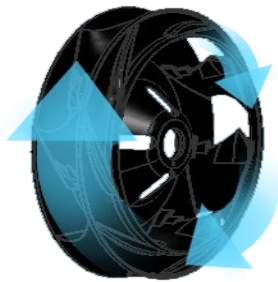

- Advanced centrifugal fan technology makes a fast airflow and reduces the indoor noise.

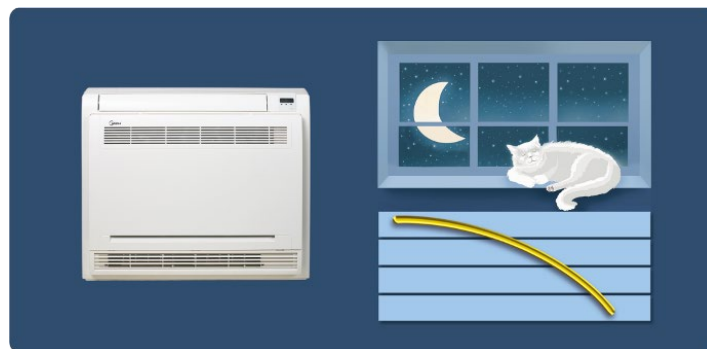

2.3.3 Ceiling-floor Units

2.3.3.1 Two-way Installation

- The rounded design of the ceiling and floor type air conditioner allows either ceiling or floor-level installation. Ceiling installation saves room space, while floor installation helps prevent the loss of warm air.

2.3.3.2 Brief Design

- Brief design that is suitable for any interior will not only give you cooling and heating performance but also upgrade your lifestyle.

2.3.3.3 3D Airflow

Vertical air flow and horizontal airflow can be adjusted by remote controller, the cooperation of the two airflow ways help to spread air comfortably throughout even a large room. With these functions, the whole room can be evenly air-conditioned for both floor-level and ceiling installation.



2.3.3.4 Optional Drainage Pipe Connection

- Both right side and left side drainage holes are available to avoid the space limitation for drainage pipe installation. Make you more convenient during installation.



2.3.3.5 Convenience Operating and Easy Maintenance

- Remote controller as standard, wired controller for optional.
- The filter without screw fixed, can be took out easily.

2.3.3.6 Easy Installation, Save Working Time

- The pipes can be connected from bottom, back and right side, makes the installation more easily.
- The wiring works can be finished before installation.

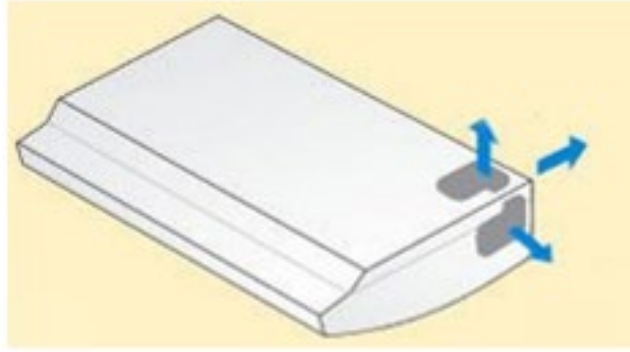

2.3.3.7 Outside Water Pump for Optional When Ceiling Installation.

2.3.4 FPA Duct Units

2.3.4.1. Higher Static Pressure

- As a ducted air conditioner with medium static pressure, it has the widest static pressure range.
- The maximum static pressure reaches 160Pa

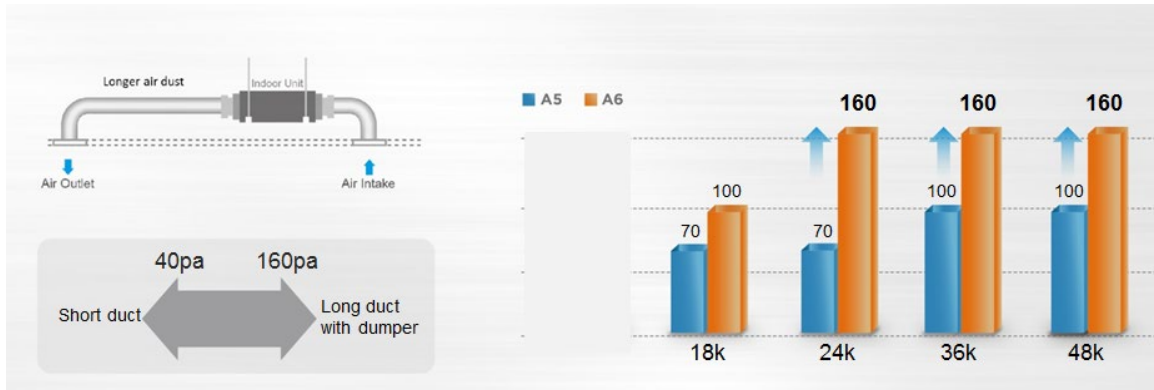

2.3.4.2. Slim Design

- The industry Lowest height is designed to be fitted into tight roof spaces.

*18K unit - 210mm, 24K/36K unit - 249mm, 48K unit - 300mm

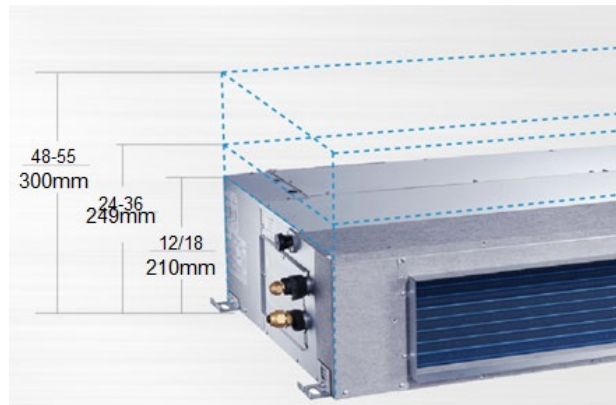

2.3.4.3. Flexible Air Intake Way (Bottom side or Rear side)

- The frame size of air inlet in rear and bottom is the same. It's very easy to switch to match different application.

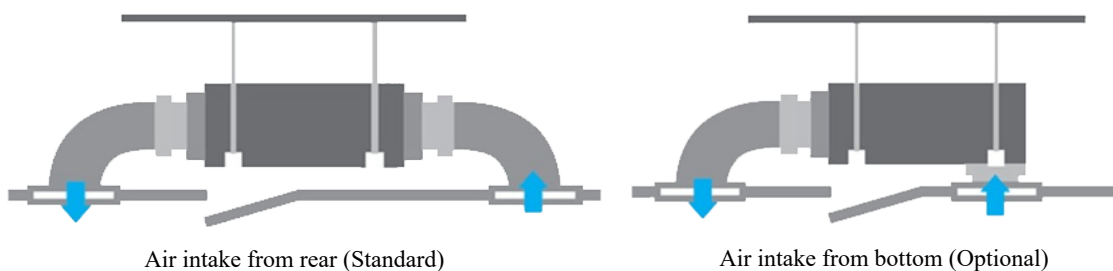

2.3.4.4. Communication wire connection

- FPA duct uses two wires without polarity connection way, which almost has no mistake during the installation.



2.3.4.5. Easy Clean

- With a larger window design, once the motor and the blower wheels have been detached, heat exchanger and water receiver tray in behind can be seen very clearly. Dust can be easily removed from the inside by vacuum



2.3.4.6. Fresh air intake function(Optional)

- Install one duct from the reserved fresh-air intake to outdoor.
Continually inhale the fresh air to improve the quality of the indoor air, fulfills air quality more healthy and comfortable.
- A ventilation motor (provided by the installer) can be installed inside the fresh air duct to improve the fresh air volume. There are reserved ports for this motor on main PCB (Standard for 3D inverter units, and only optional for DC inverter 53~160 units).

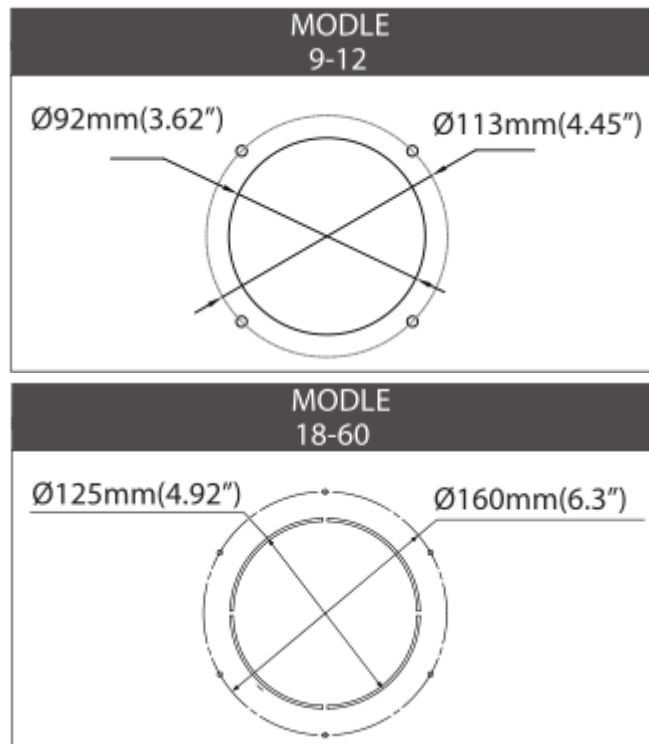

2.3.4.7. Drain pump (Optional)

- Built-in drain pump can lift the water to 750mm upmost, which widens the drainage piping range.

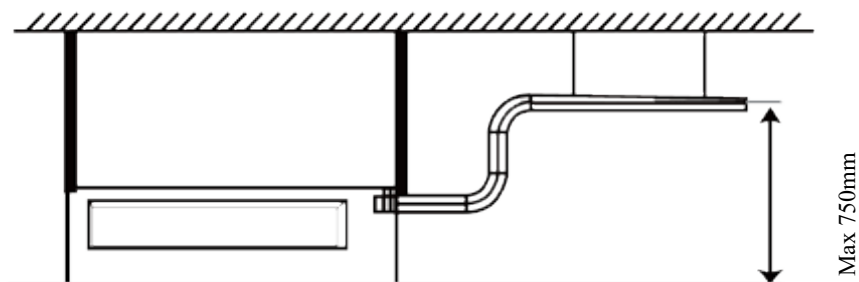

2.3.5 HESP DUCT Units

2.3.5.1 High static pressure design

- Max static pressure of indoor unit is 200Pa.
- The longest distance of air supply is 40m, the max height of air supply is 6.5m.
- Specially recommended for spacious and large rooms like large stores and factories.

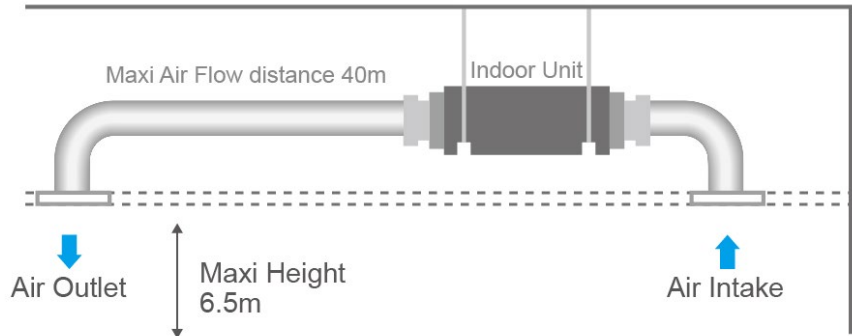

2.3.5.2 Easy maintenance

- The unit can be opened from top or bottom.

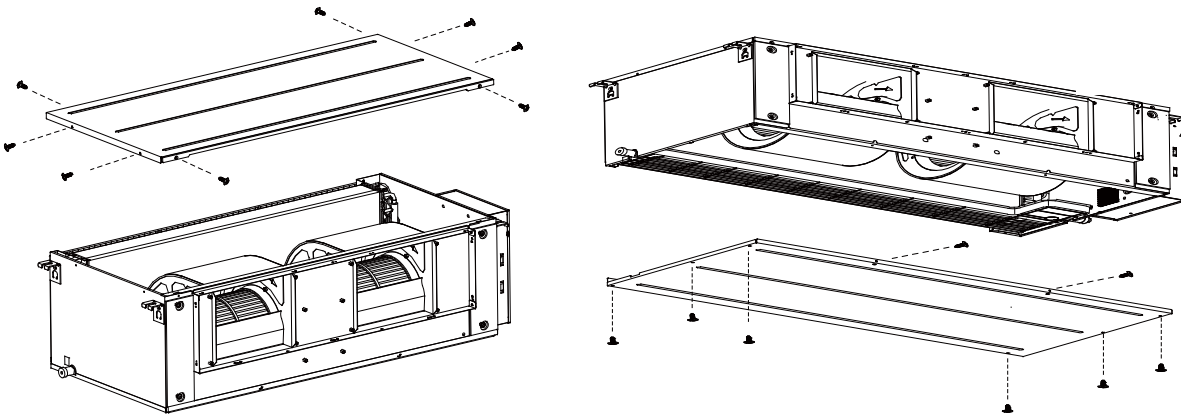

- The air outlet flange is isolated from either top panel or base panel, which makes the maintenance much easier when connecting duct.

2.3.5.3 Flexible Installation

- Different solutions for any shape room by using kinds of air distribution ducts.

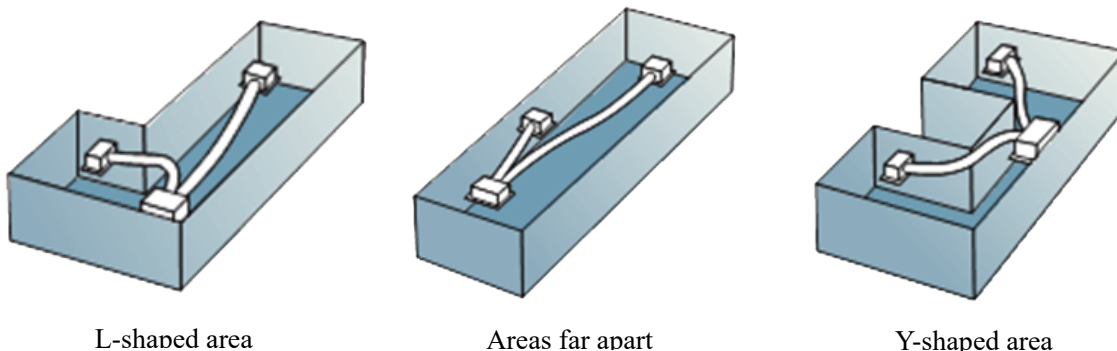

L-shaped area

Areas far apart

Y-shaped area

3. Dimension

3.1 Indoor Unit

Cassette Units TPA (9K, 12K, 18K)

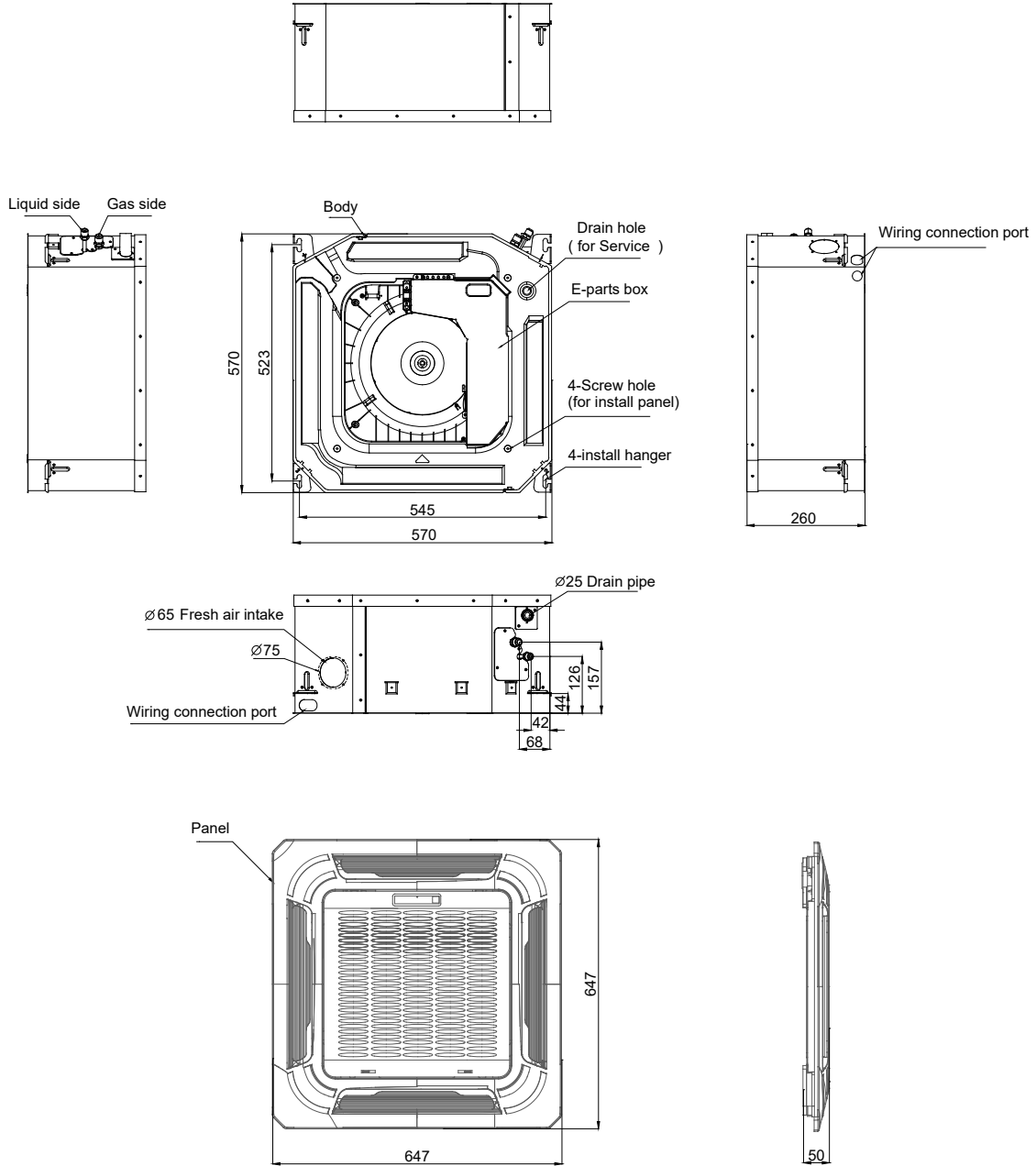

Cassette Units TPA (24K, 36K, 48K)

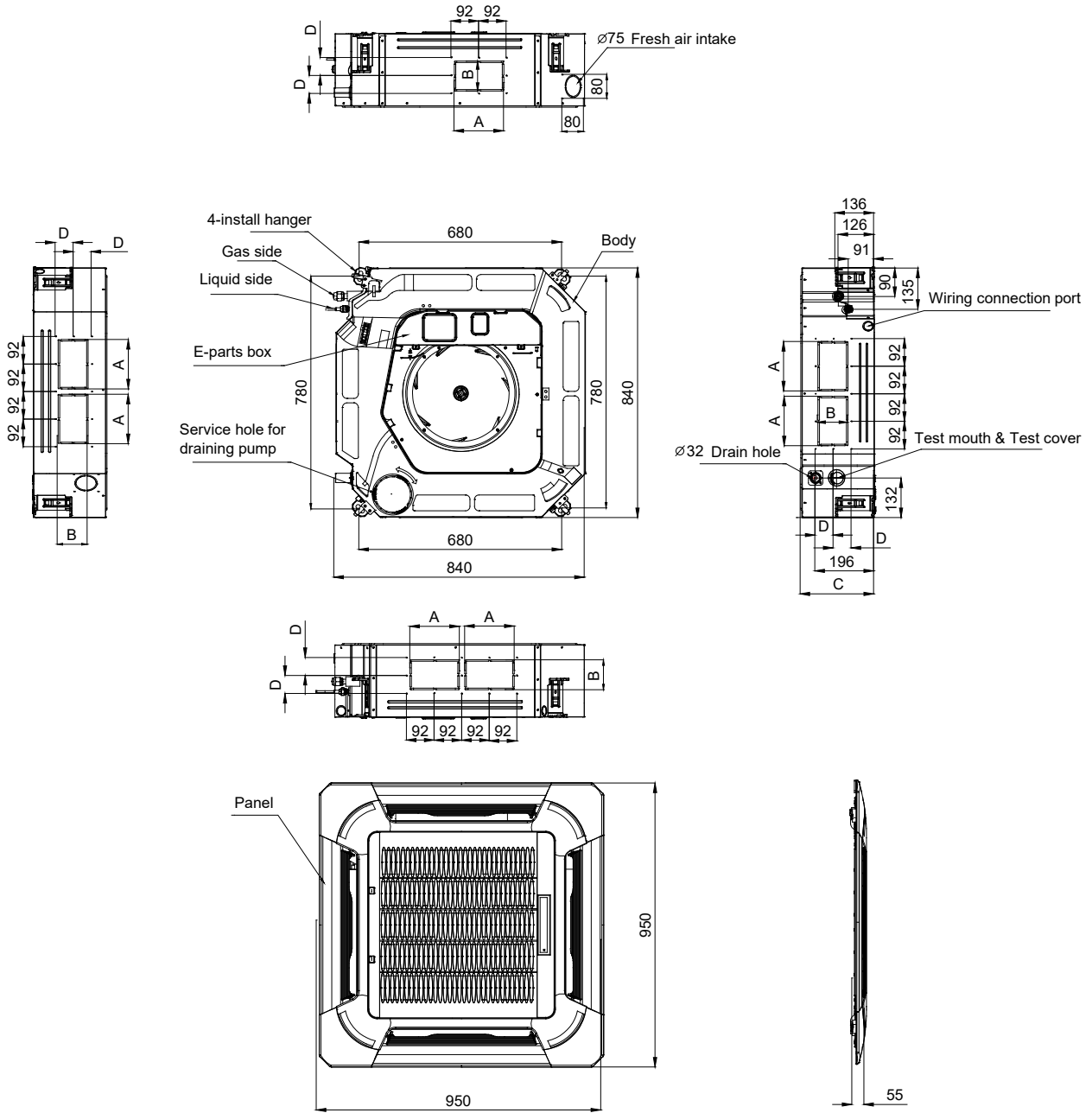

Capacity (Btu/h)	Unit	A	B	C	D
24K	mm	160	75	205	50
	inch	6.30	2.95	8.07	1.97
36K	mm	160	95	245	60
	inch	6.30	3.74	9.65	2.36
48K	mm	160	95	287	60
	inch	6.30	3.74	11.30	2.36

New Cassette TIP Units(24K, 36K, 48K)

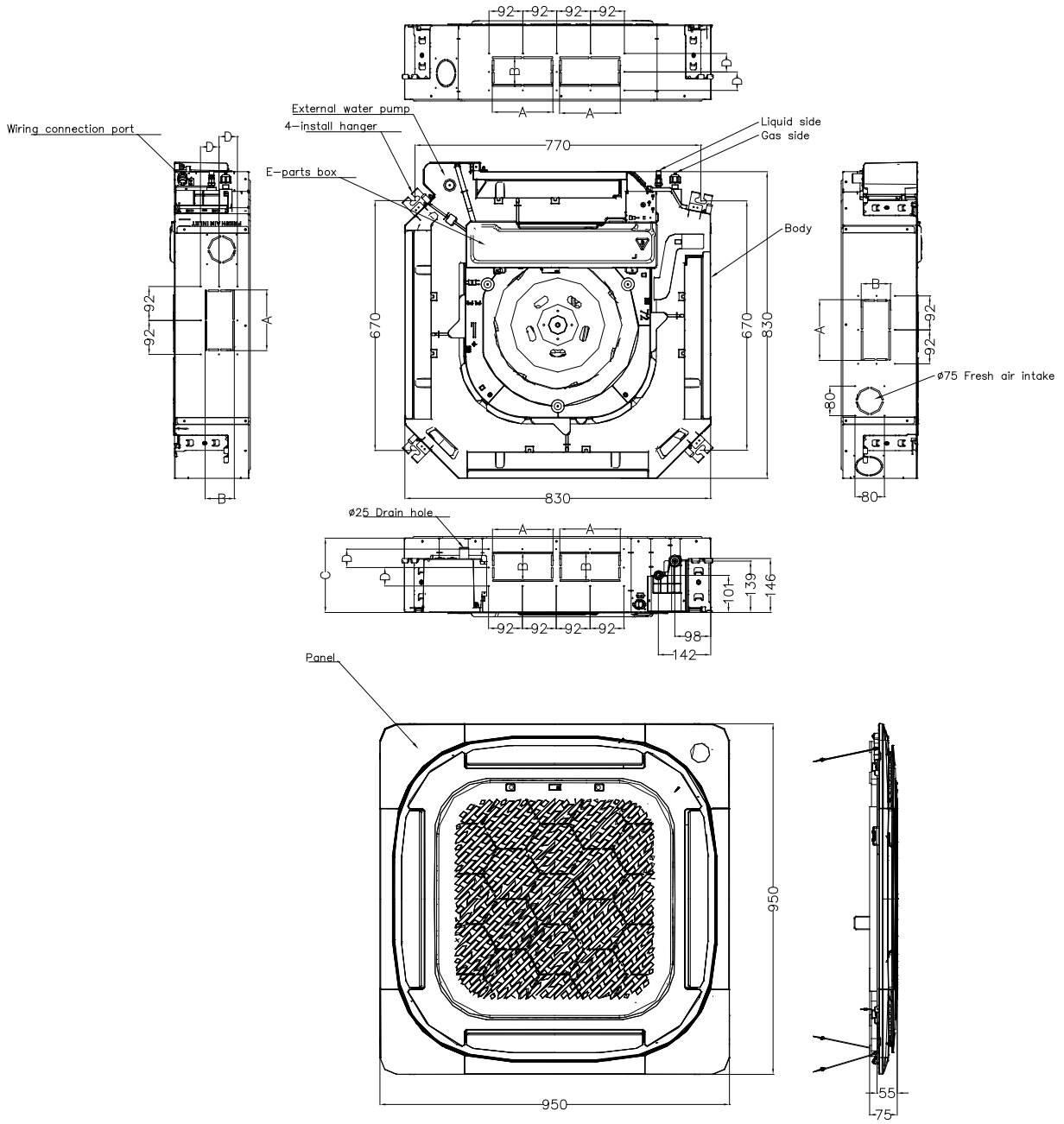

Capacity (Btu/h)	Unit	A	B	C	D
24K	mm	165	80	205	50
	inch	6.5	3.15	8.07	1.97
36K	mm	165	100	245	60
	inch	6.5	3.64	9.65	2.36
48K	mm	165	100	287	60
	inch	6.5	3.64	11.30	2.36

Console Units (for special area)

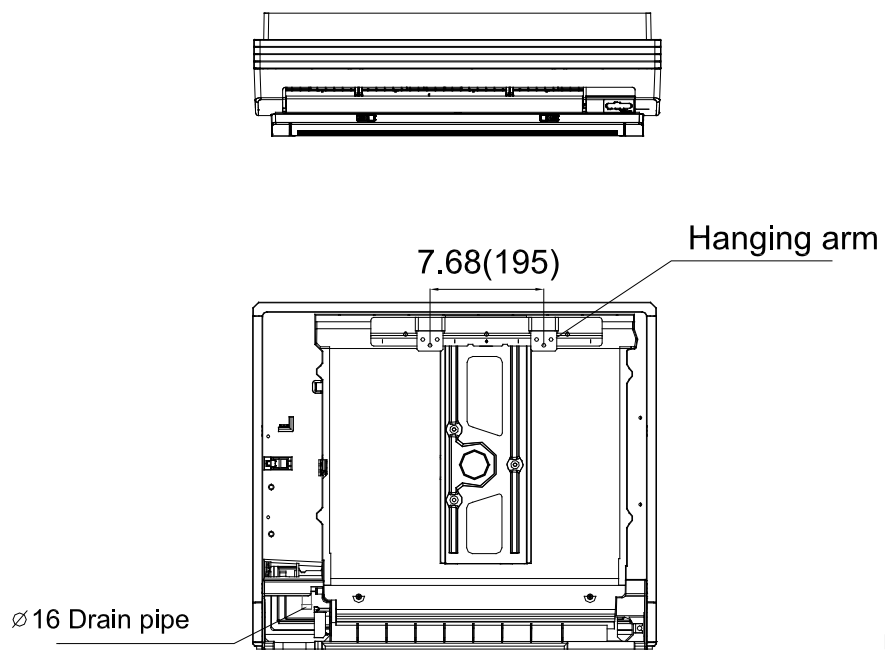
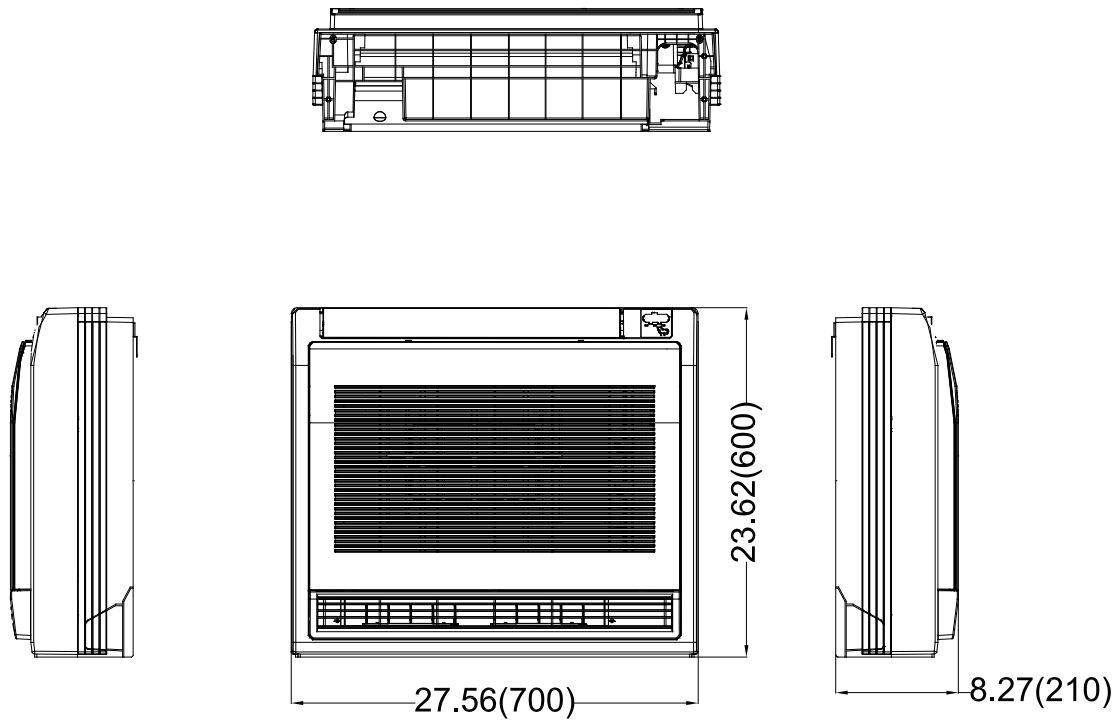

Unit: inch(mm)

Ceiling-floor Units (18K-60K)

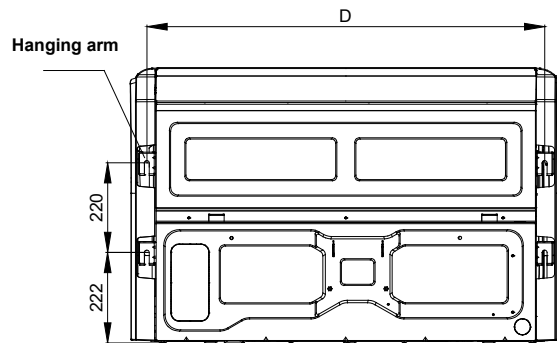
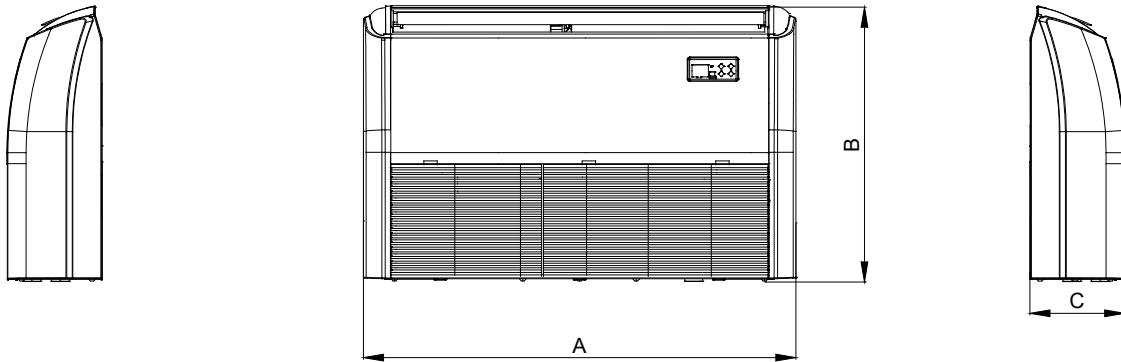
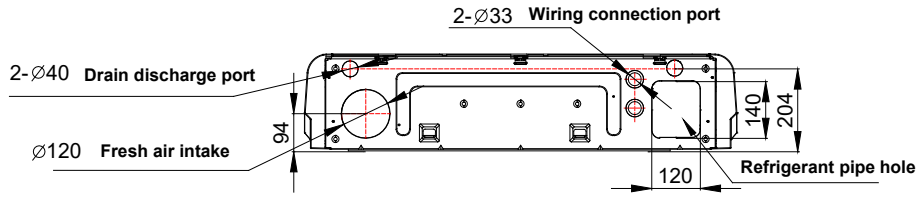

Capacity (Btu/h)	Unit	A	B	C	D
18K / 24K	mm	1068	675	235	983
	inch	42.05	26.57	9.25	38.70
36K	mm	1285	675	235	1200
	inch	50.59	26.57	9.25	47.24
48K/60K	mm	1650	675	235	1565
	inch	64.96	26.57	9.25	61.61

FPA Duct Units

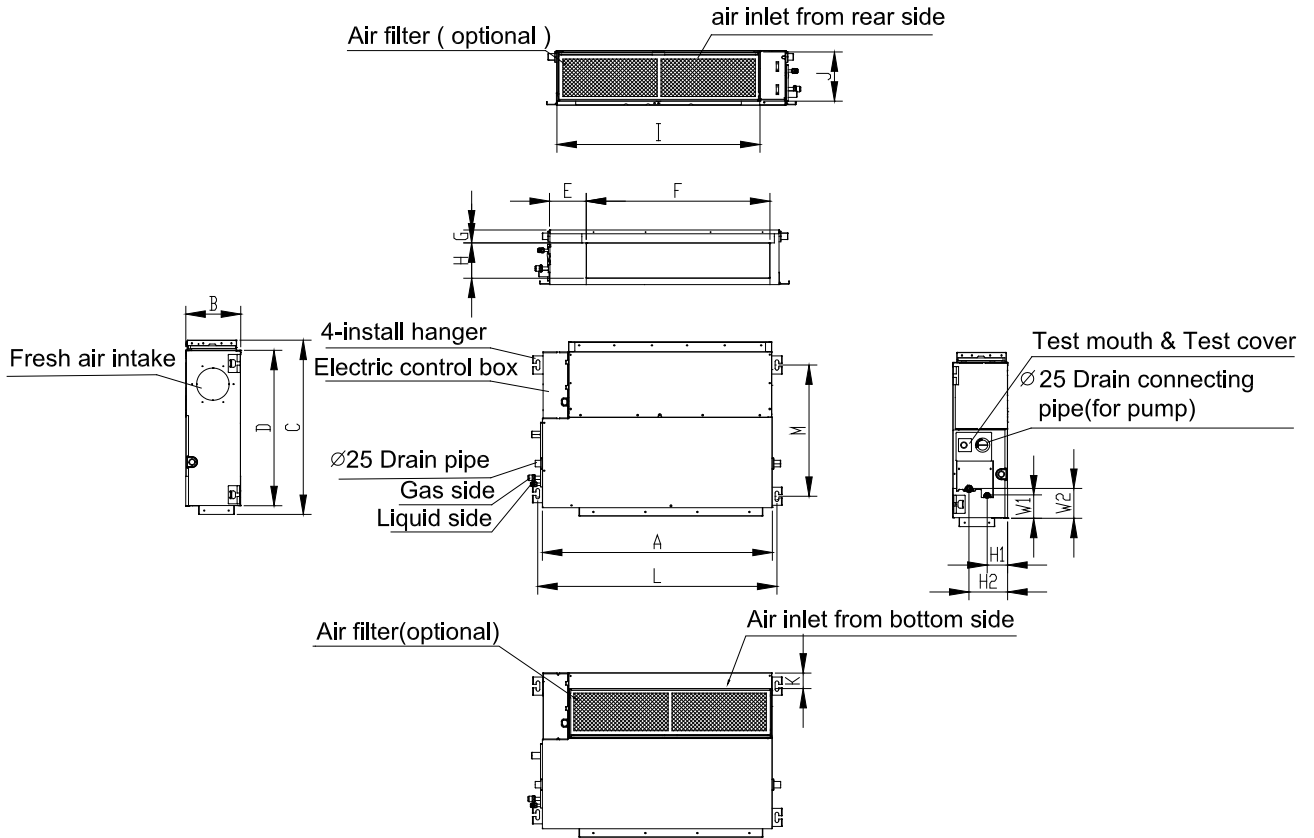

Model (KBtu/h)	unit	A	B	C	D	E	F	G	H	I	J	K	L	M	H1	H2	W1	W2
9/12	mm	700	200	506	450	137	537	30	152	599	186	50	741	360	84	140	84	84
	inch	27.6	7.9	19.9	17.7	5.4	21.1	1.2	6.0	23.6	7.3	2.0	29.2	14.2	3.3	5.5	3.3	3.3
18	mm	880	210	674	600	140	706	50	136	782	190	40	920	508	78	148	88	112
	inch	34.6	8.3	26.5	23.6	5.5	27.8	2.0	5.4	30.8	7.5	1.6	36.2	20.0	3.1	5.8	3.5	4.4
24	mm	1100	249	774	700	140	926	50	175	1001	228	5	1140	598	80	150	130	155
	inch	43.3	9.8	30.5	27.6	5.5	36.5	2.0	6.9	39.4	9.0	0.2	44.9	23.5	3.1	5.9	5.1	6.1
36	mm	1360	249	774	700	140	1186	50	175	1261	228	5	1400	598	80	150	130	155
	inch	53.5	9.8	30.5	27.6	5.5	46.7	2.0	6.9	49.6	9.0	0.2	55.1	23.5	3.1	5.9	5.1	6.1
48	mm	1200	300	874	800	123	1044	50	227	1101	280	5	1240	697	80	150	185	210
	inch	47.2	11.8	34.4	31.5	4.8	41.1	2.0	8.9	43.3	11.0	0.2	48.8	27.4	3.1	5.9	7.3	8.3

9/12K with external condensate pump(optional)

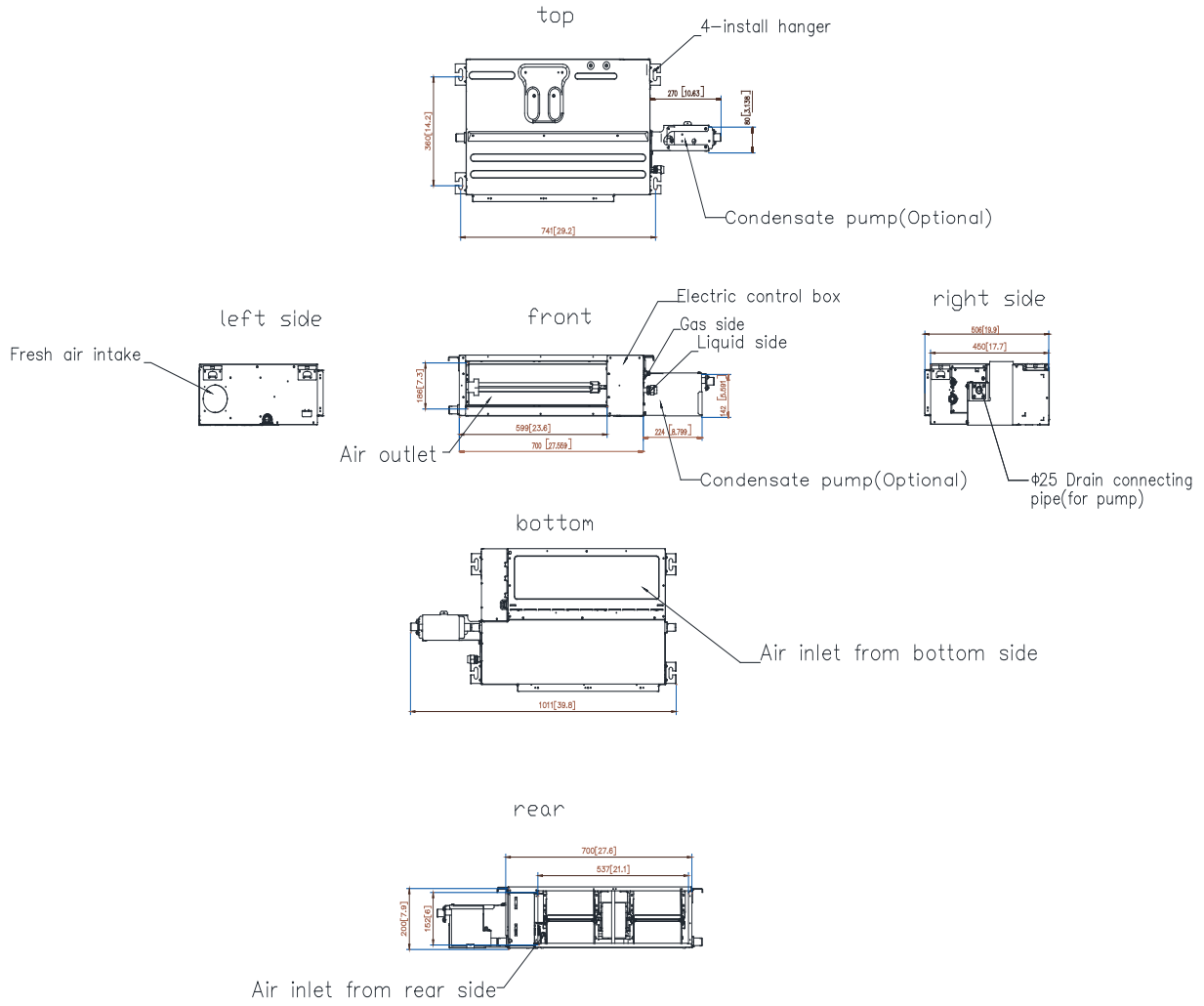

18K with external condensate pump(optional)

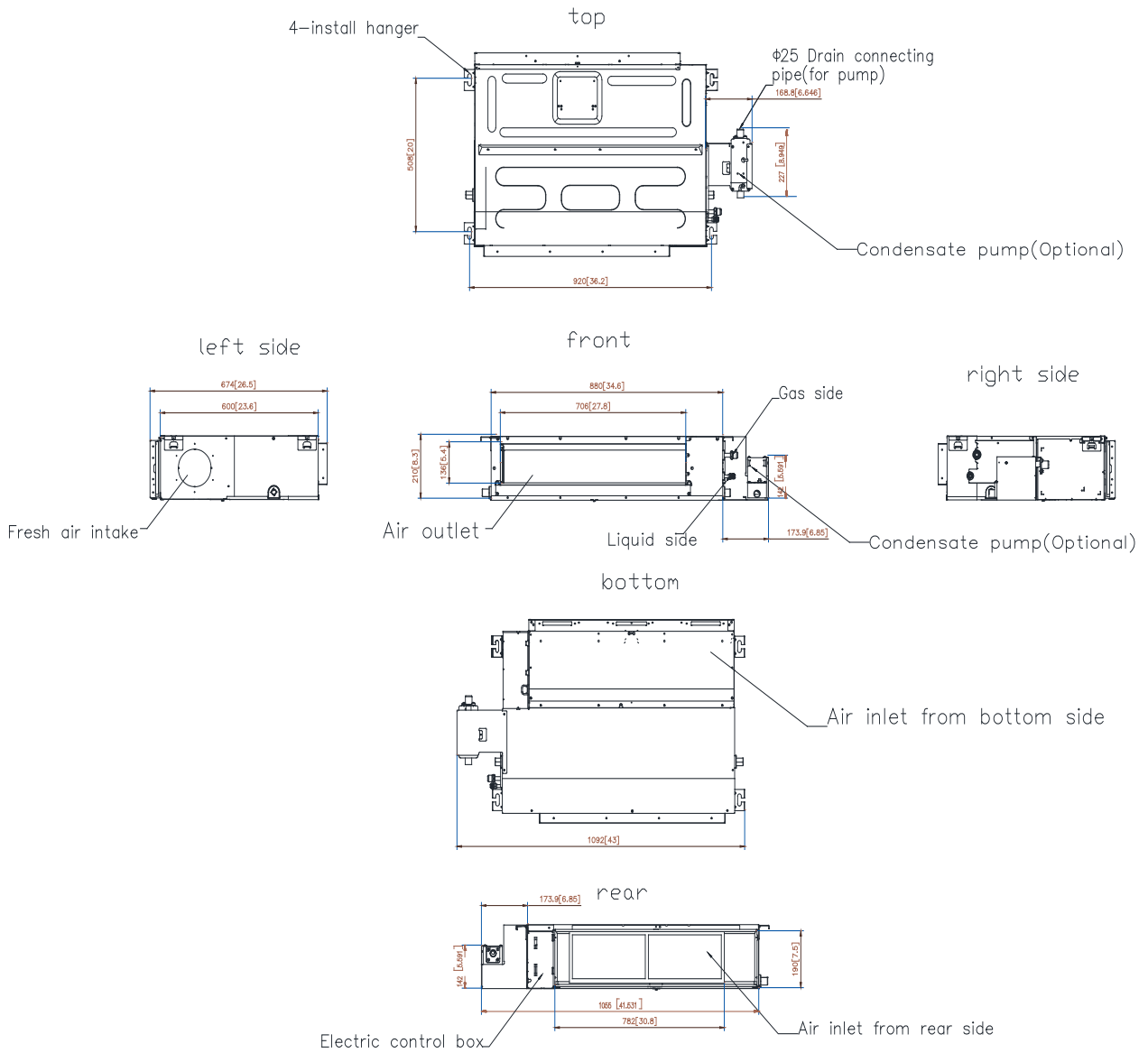

CPA-60DU

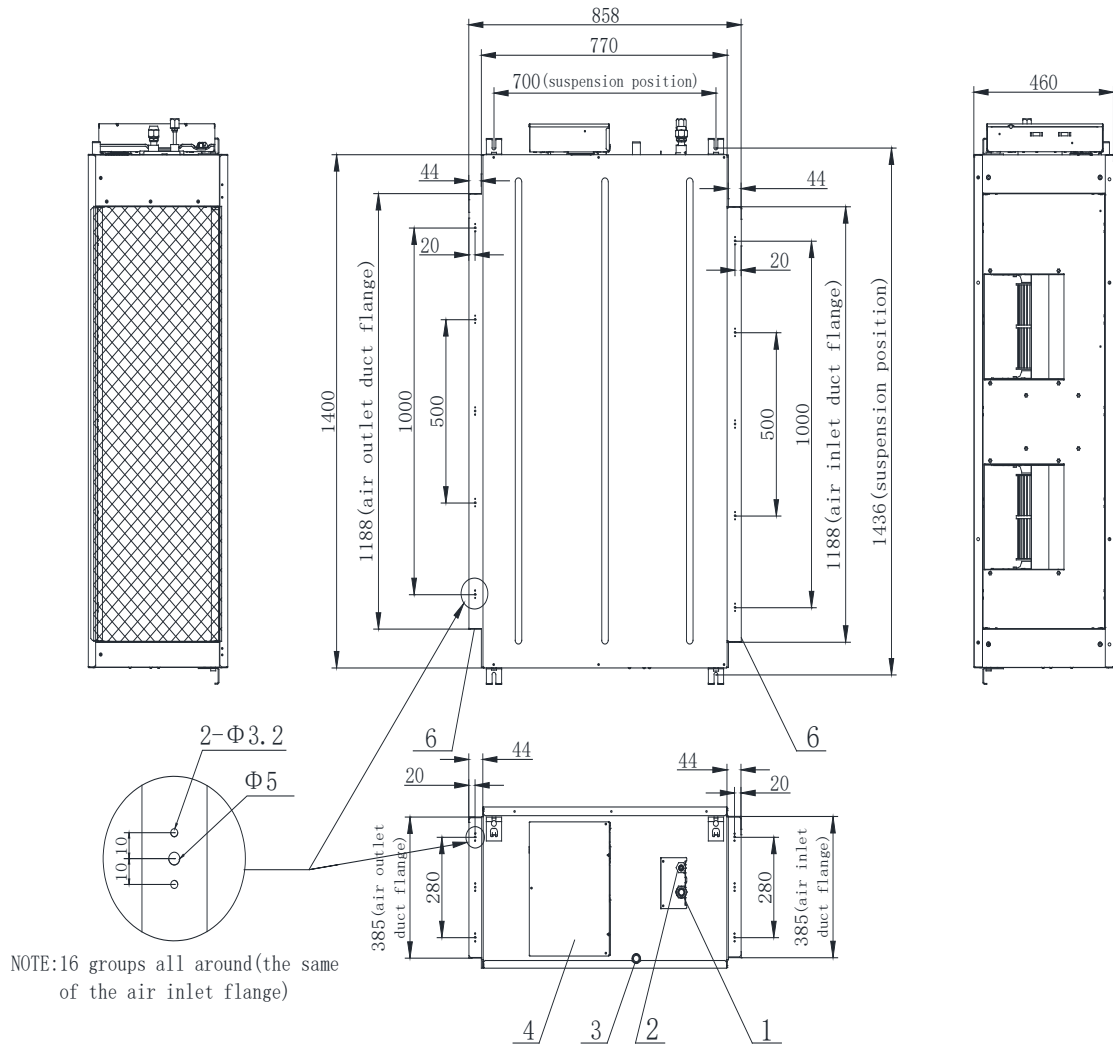

NOTE:16 groups all around(the same of the air inlet flange)

3.2 Outdoor Unit

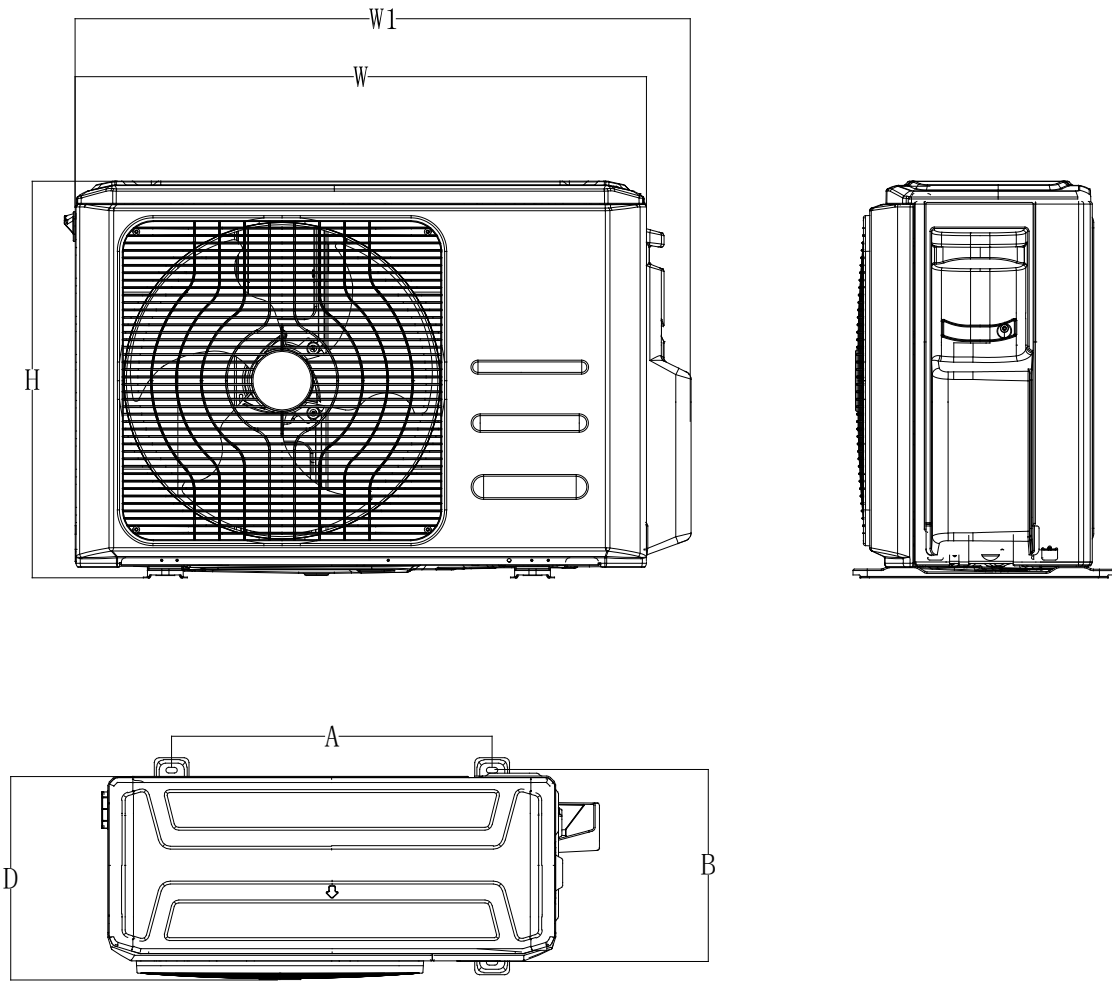

Note: The above drawing is only for reference. The appearance of your units may be different.

Model	unit	W	D	H	W1	A	B
CHF24CD(O)	mm	946	410	810	1030	673	403
CZP24CD(O)	inch	37.2	16.1	31.9	40.6	26.5	15.9

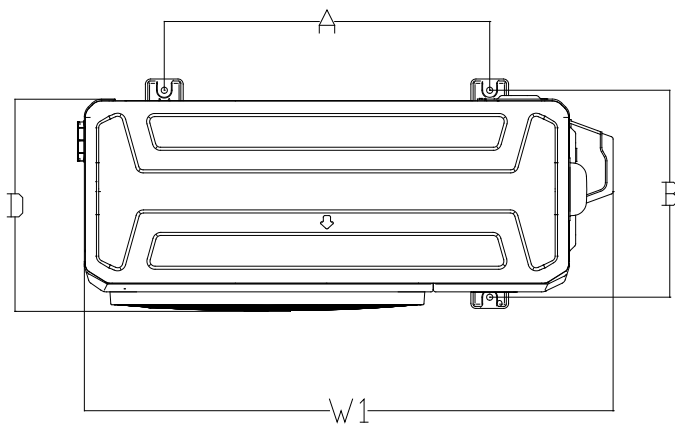
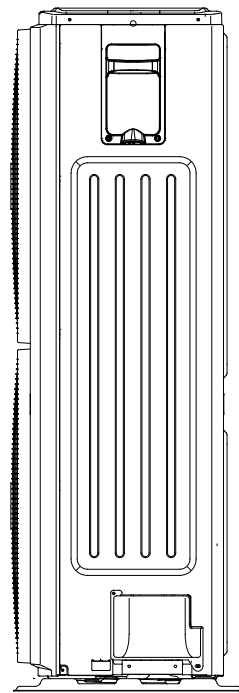
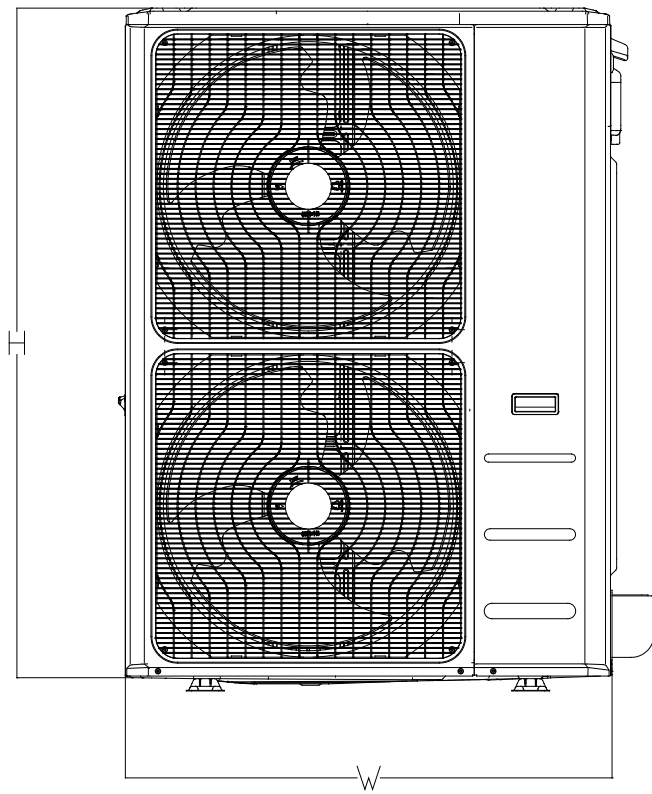

Model	Unit	W	D	H	W1	A	B
CHF36CD(O)	mm	952	415	1333	1045	634	404
CZP48CD(O)							
CHF48CD(O)	inch	37.5	16.3	52.5	41.1	25.0	15.9
CZP60CD(O)							

CZP09CD(O), CZP12CD(O)

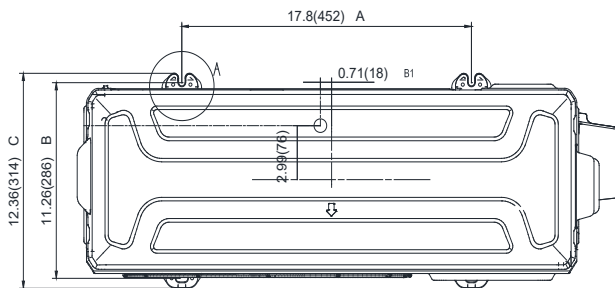
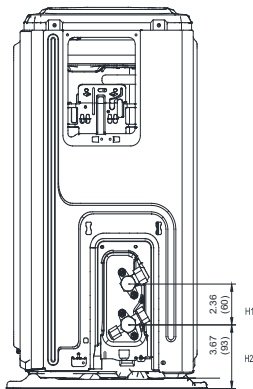
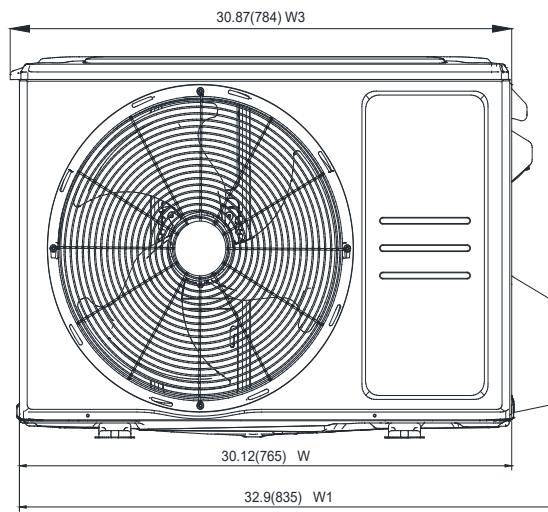
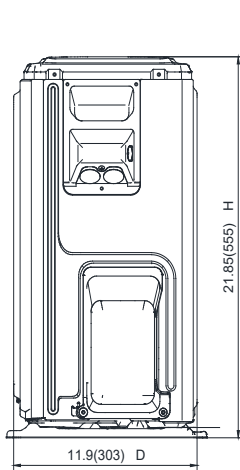

DETAIL A
SCALE 1:2

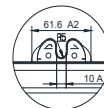

CHF09CD(O), CHF12CD(O)

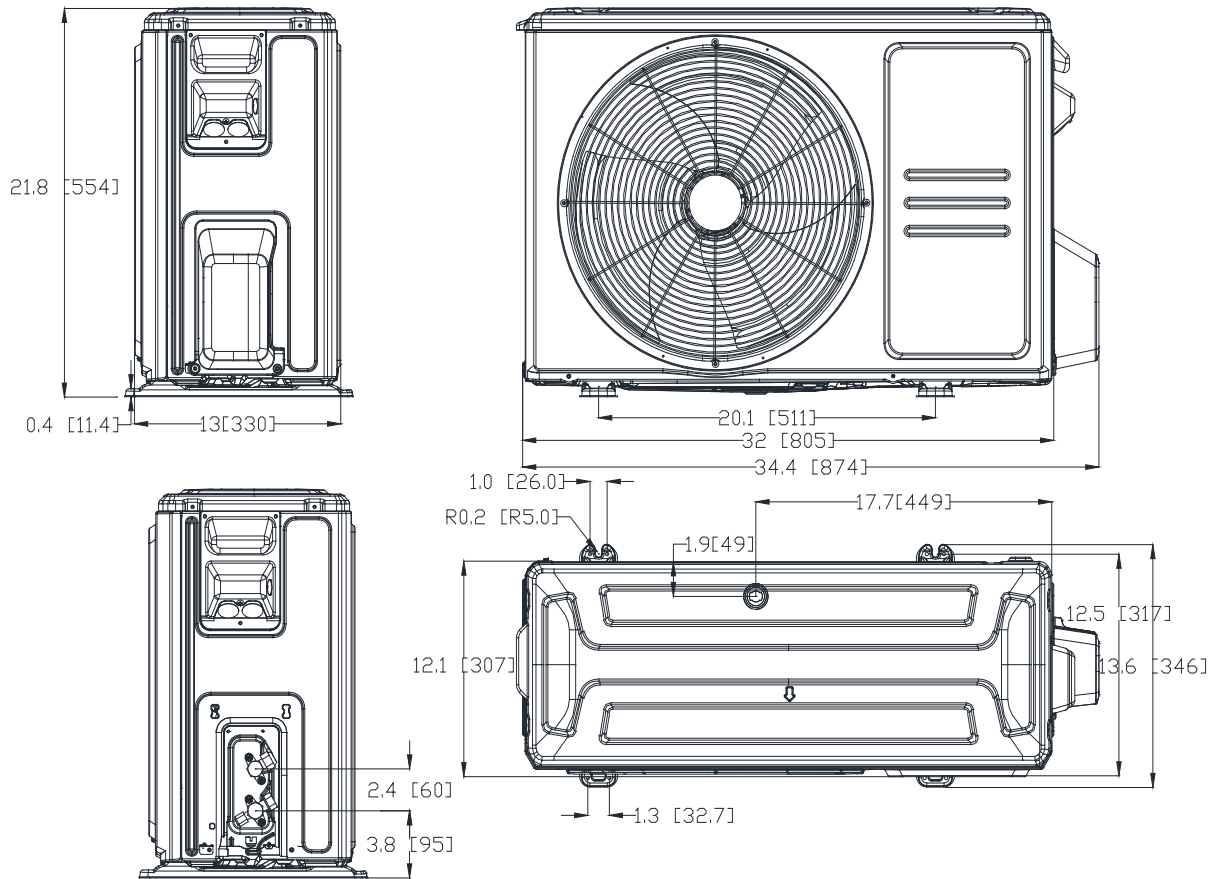

CHF18CD(O), CZP18CD(O)

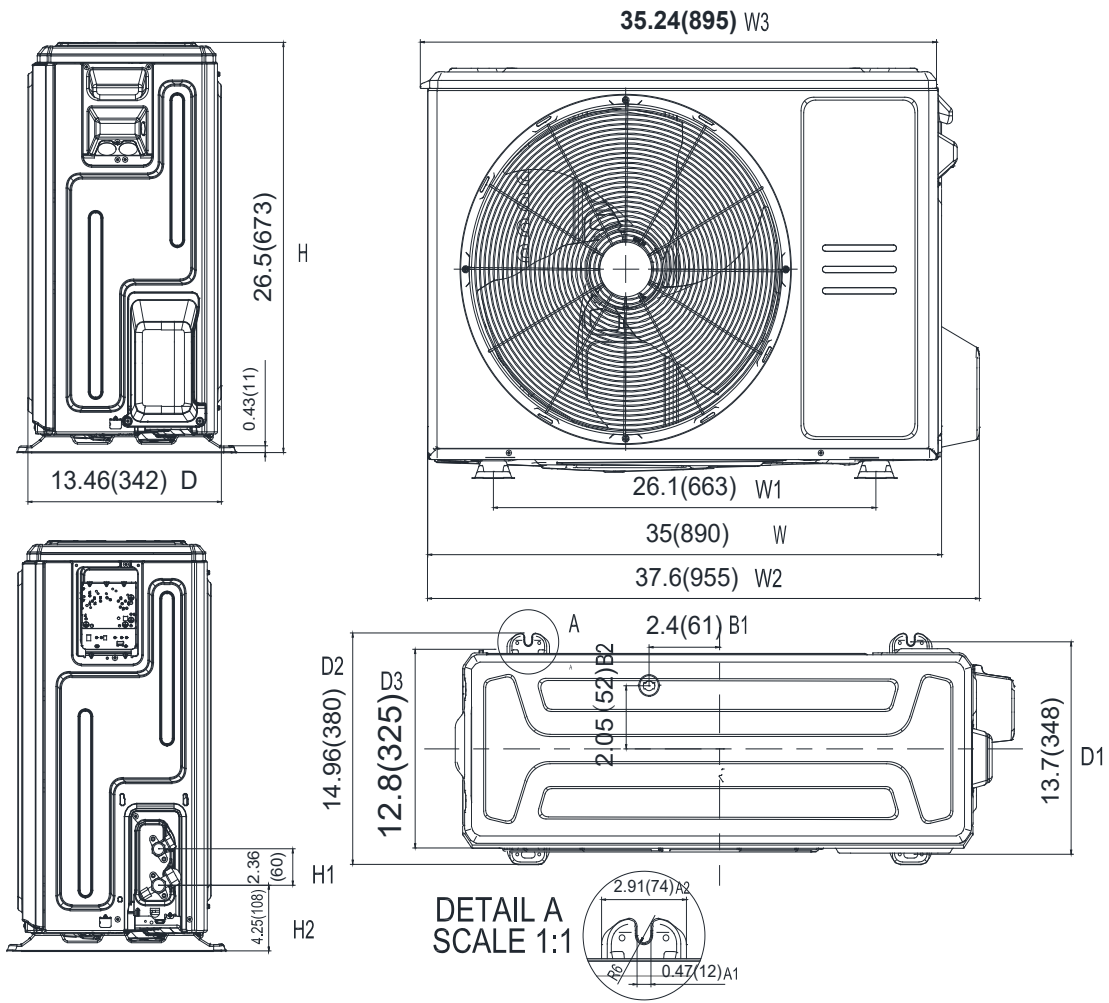

4. Service Space

4.1 Indoor Unit

FPA Duct Units

Ensure enough space required for installation and maintenance.

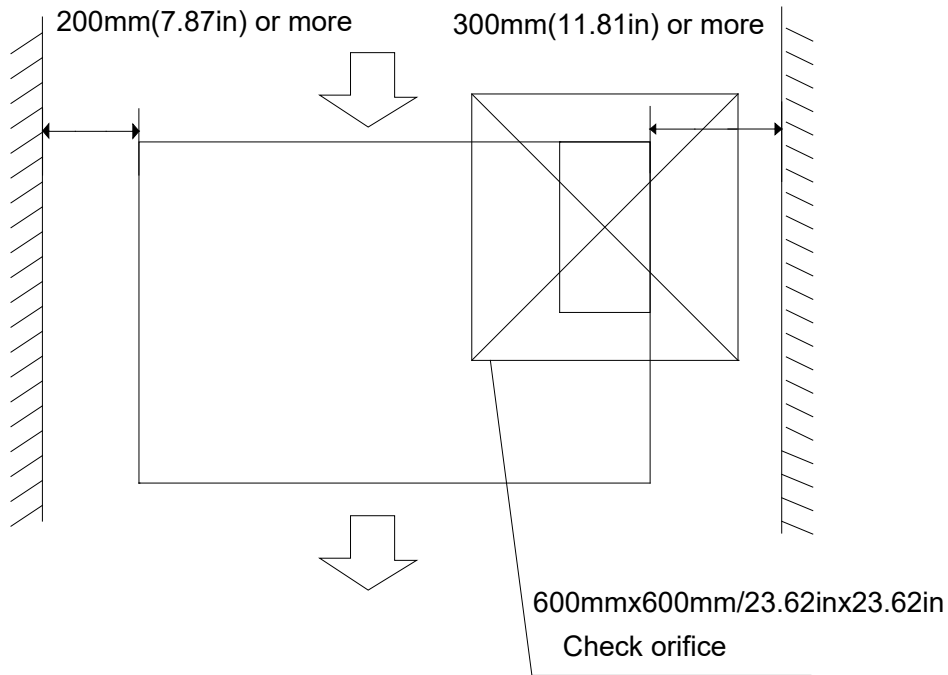

All the indoor units reserve the hole to connect the fresh air pipe. The hole size as following

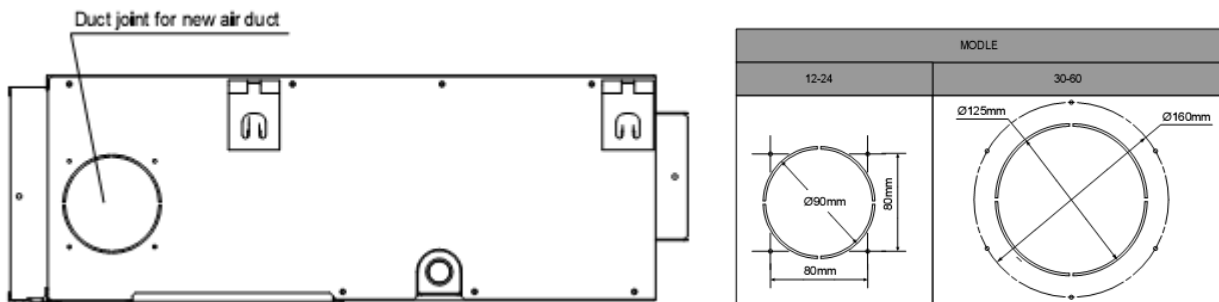

Cassette Units

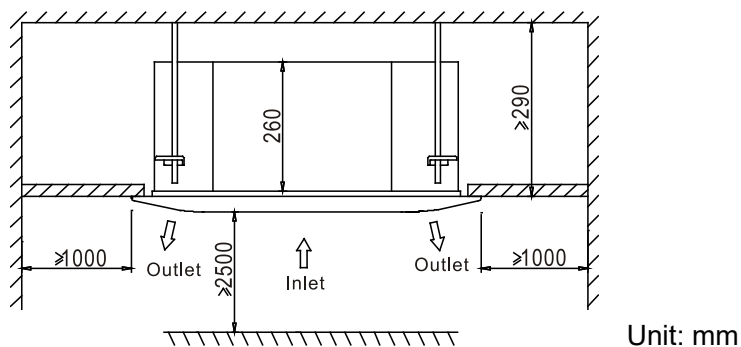

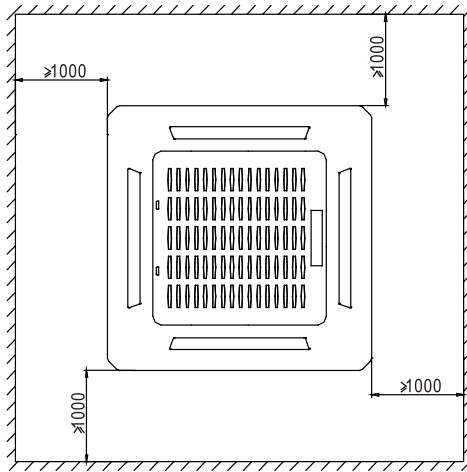

New Cassette Units

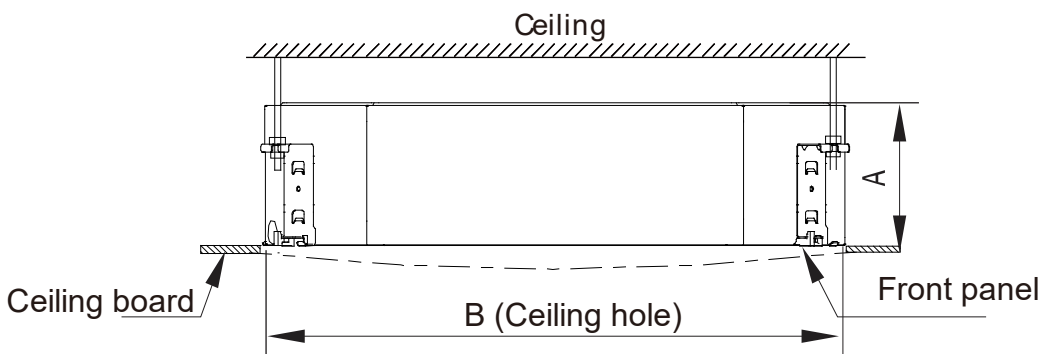
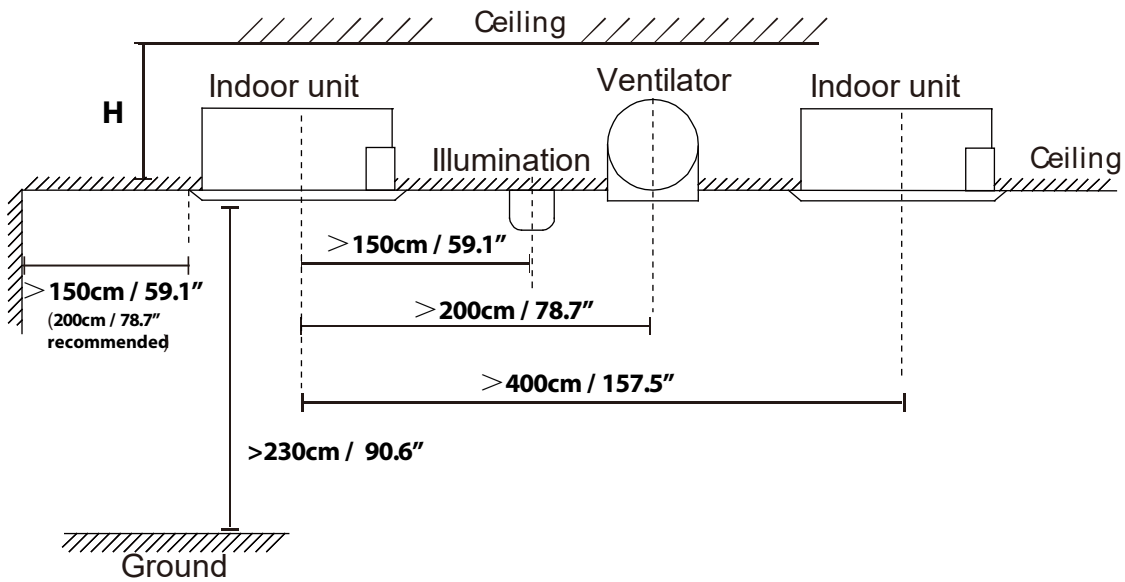

Capacity (kBtu/h)	A(mm/inch)	H(mm/inch)	B(mm/inch)
24	205/8.07	>230/9.06	900/35.4
36	245/9.65	>271/10.7	
48	287/11.3	>313/12.3	

Console Units

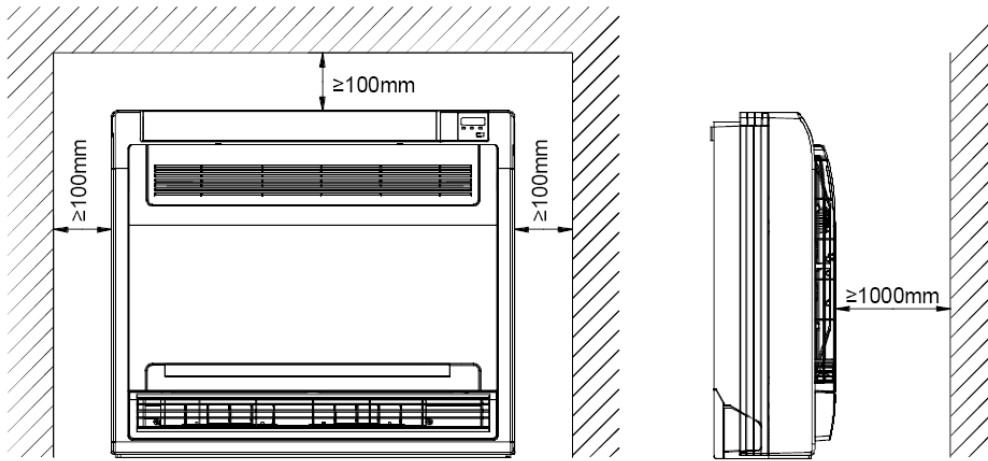

Ceiling-floor Units

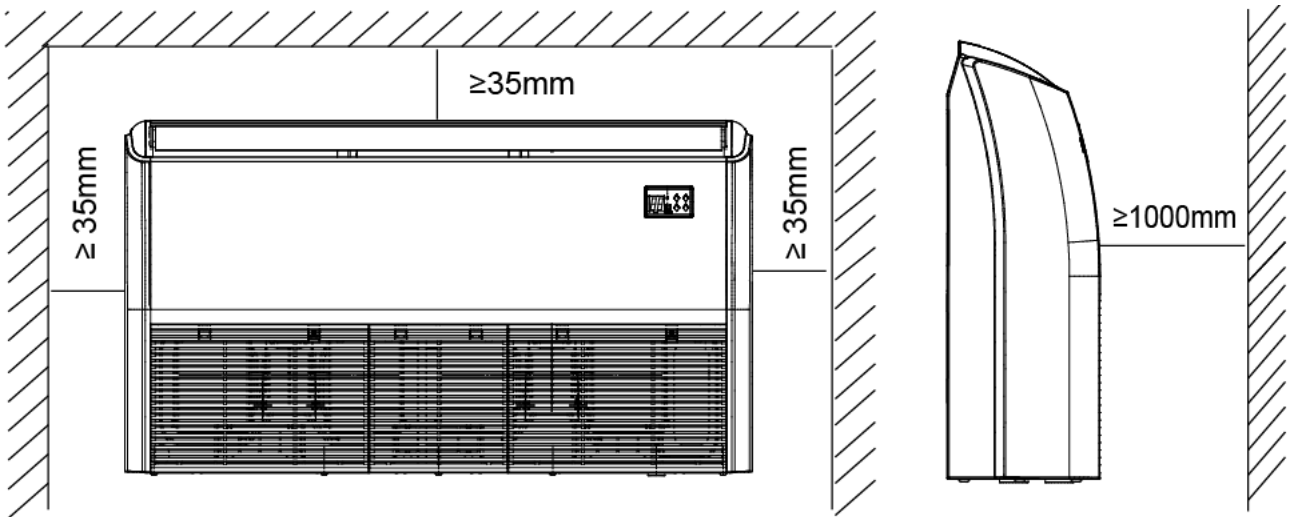

HESP DUCT

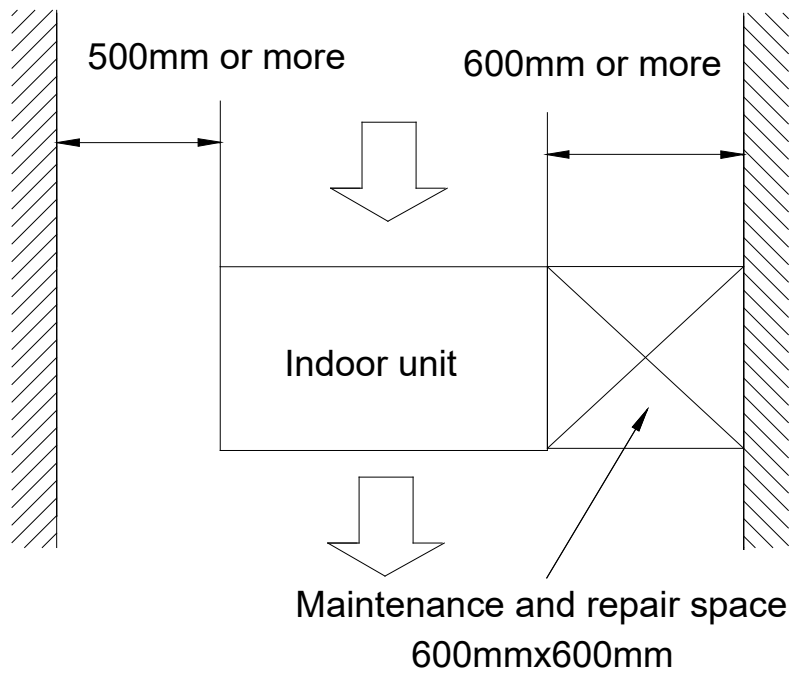

4.2 Outdoor Unit

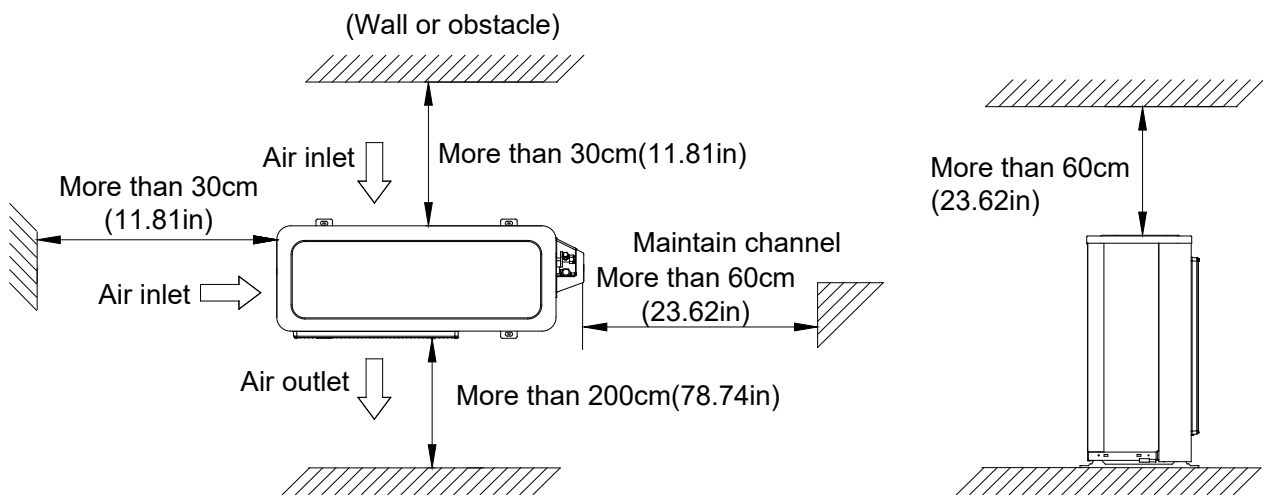

5. Refrigerant Cycle Diagram

CHF09CD(O),CHF12CD(O)

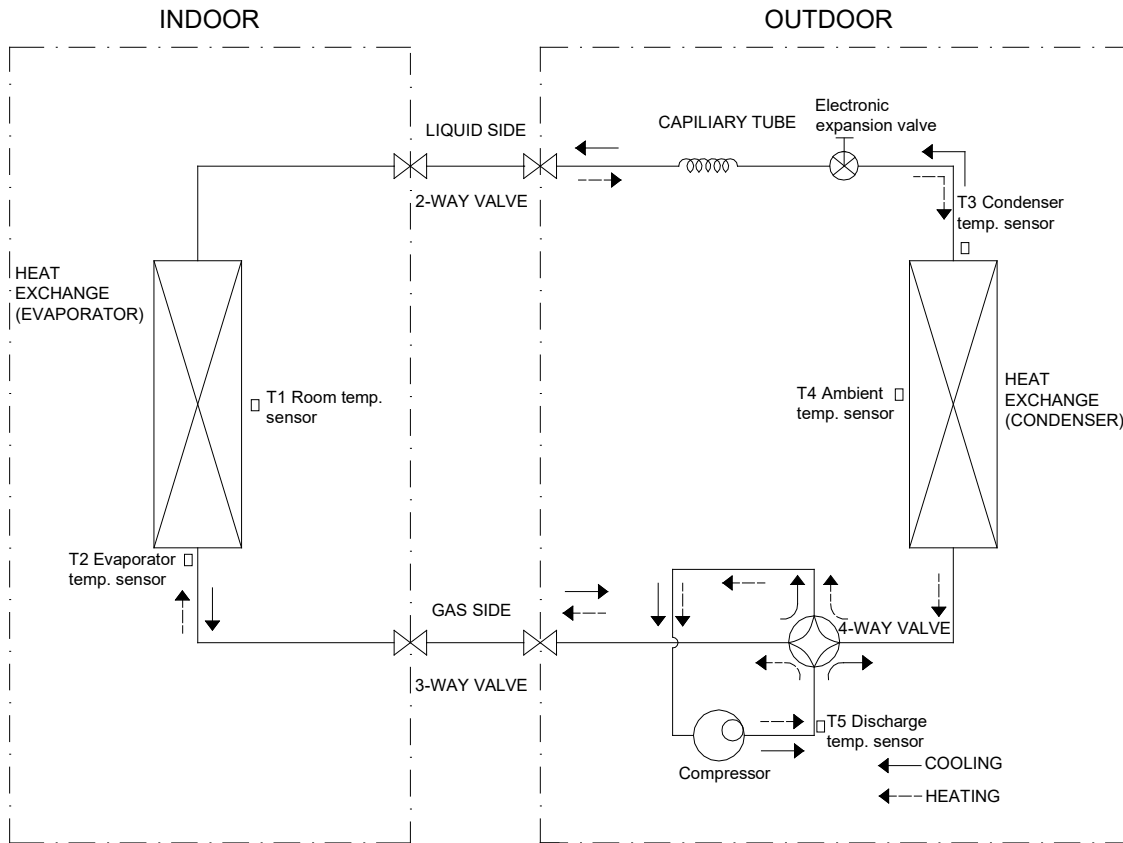

CZP09CD(O), CZP12CD(O)

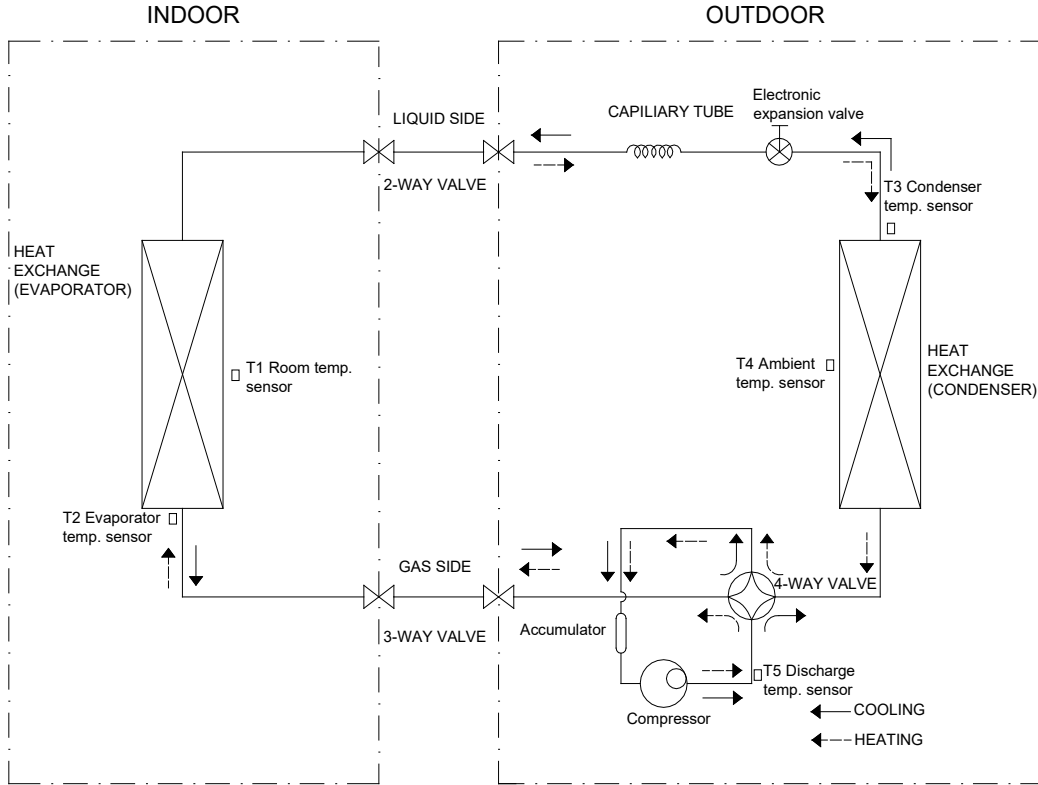

CZP36CD(O), CZP48CD(O), CZP60CD(O)

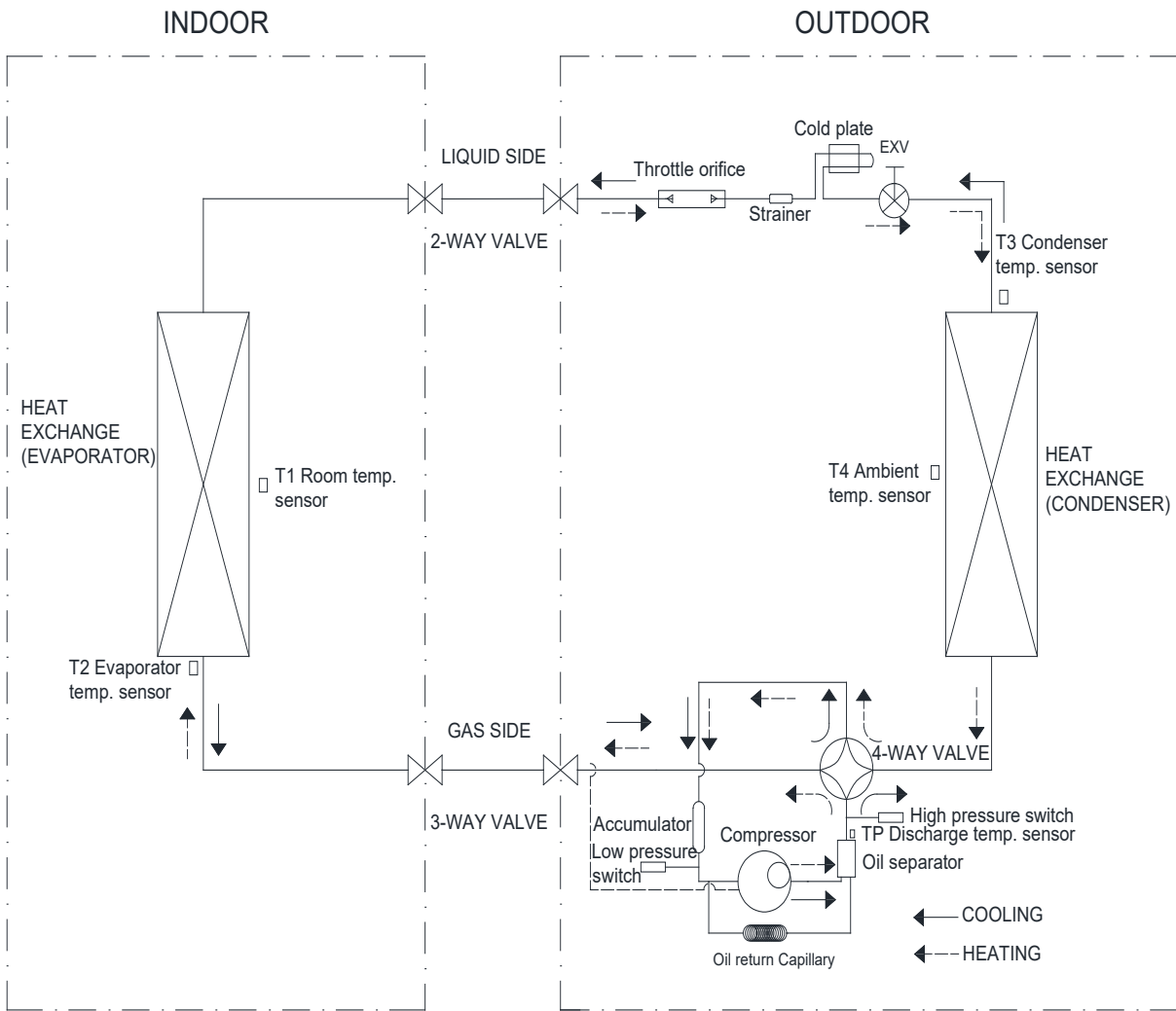

CHF18CD(O), CZP18CD(O), CHF24CD(O), CZP24CD(O)

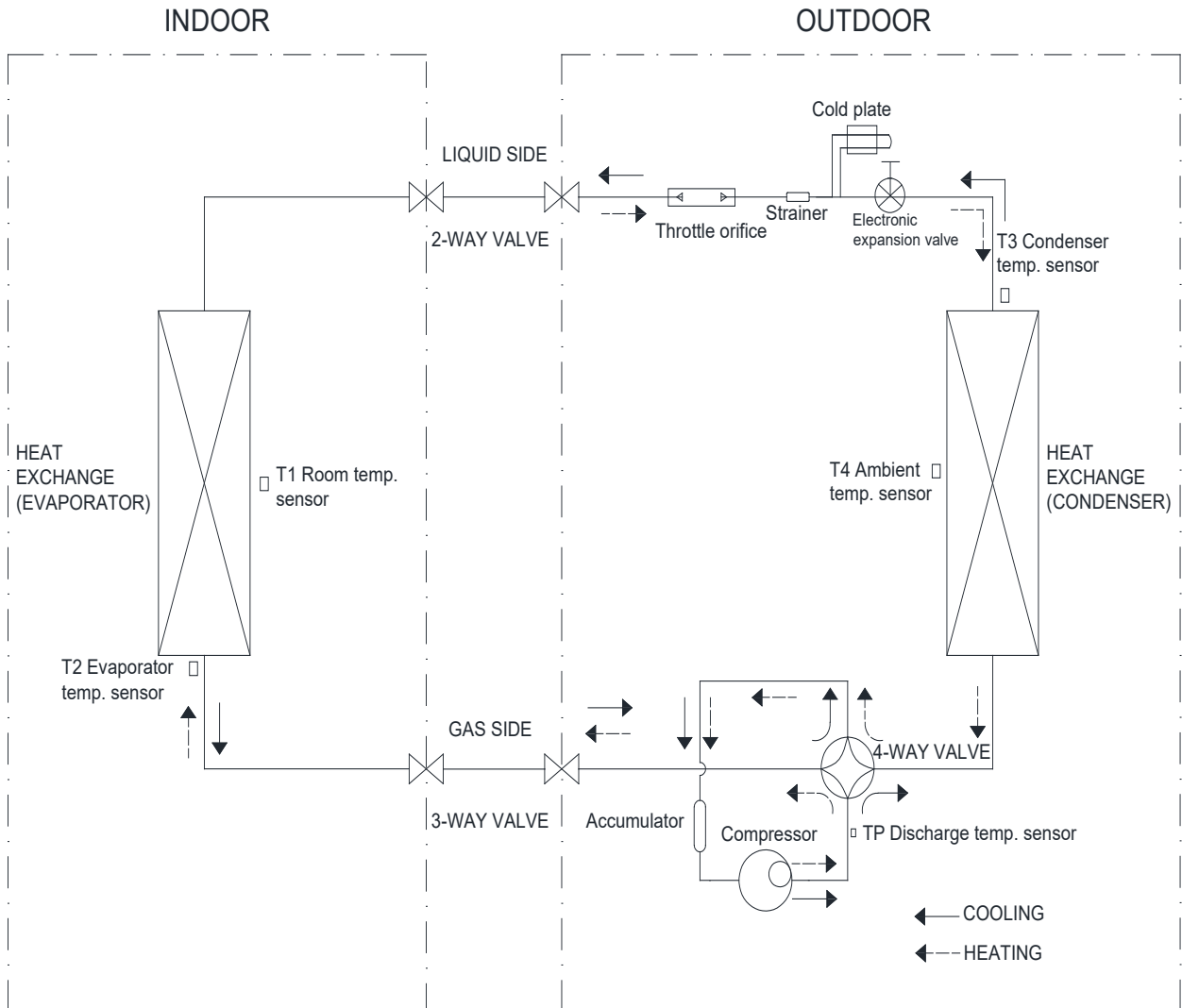

For CHF18CD(O), there is an accumulator.

6. Wiring Diagram

6.1 Indoor Unit

TPA-09, TPA-12,
TPA-18,

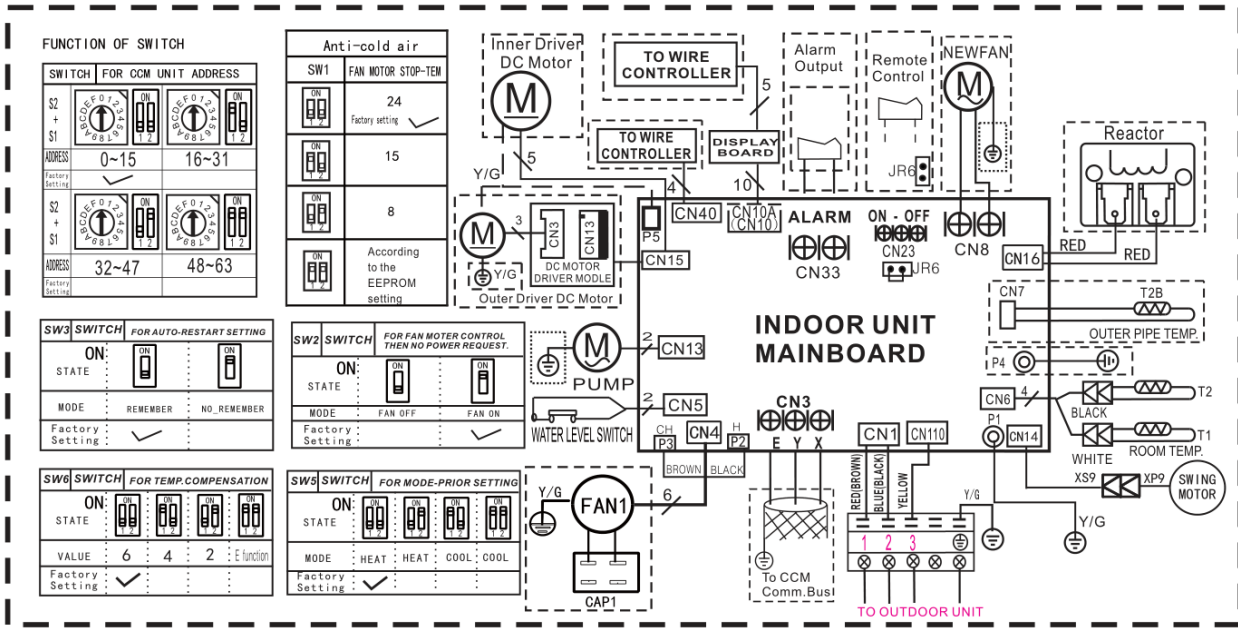

TIP24

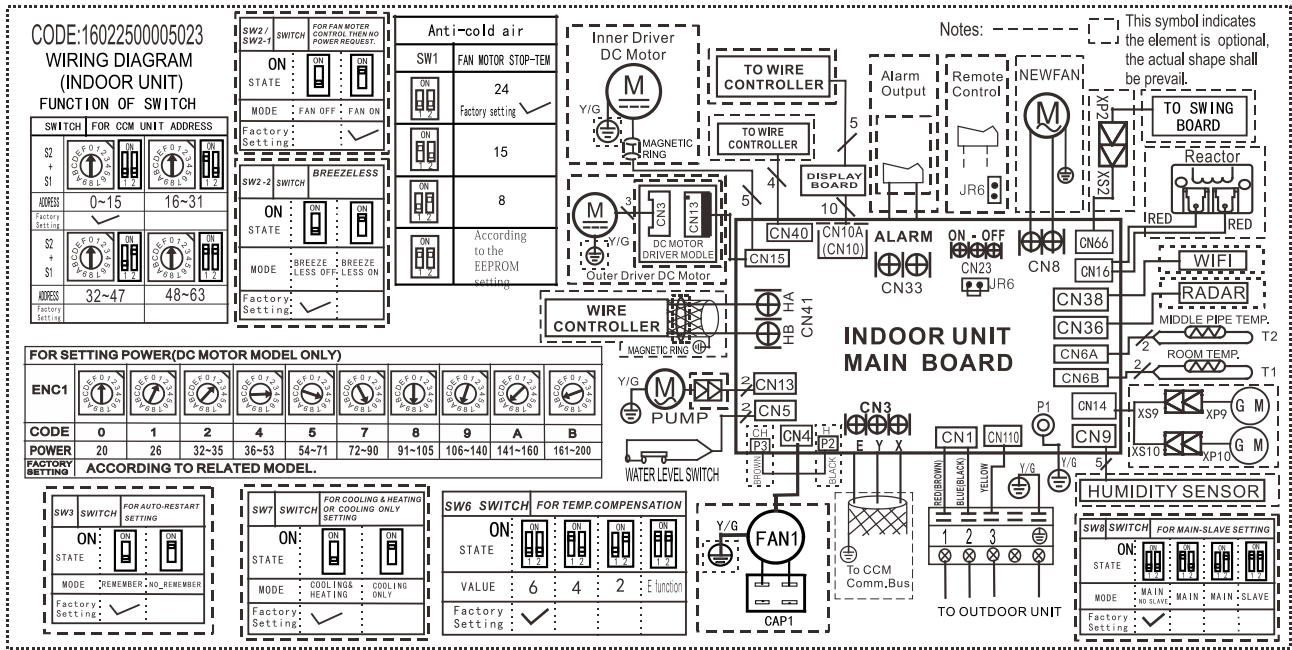

TIP36, TIP48

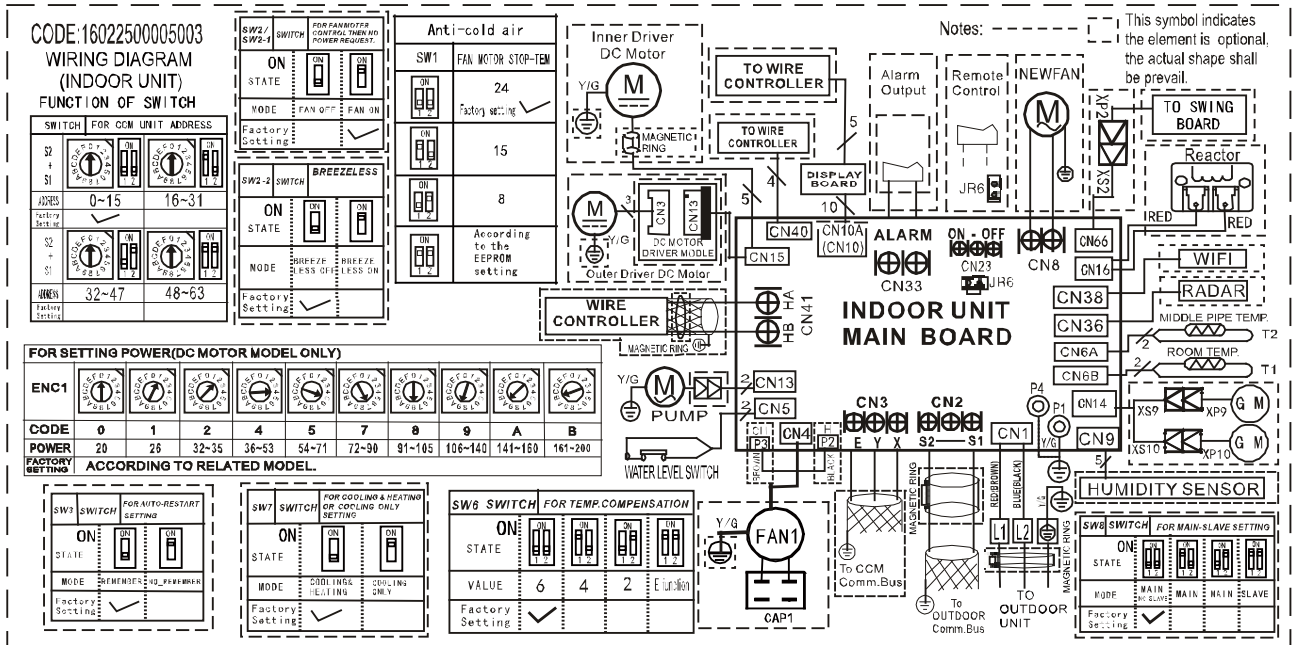

FPA-18, FPA-24

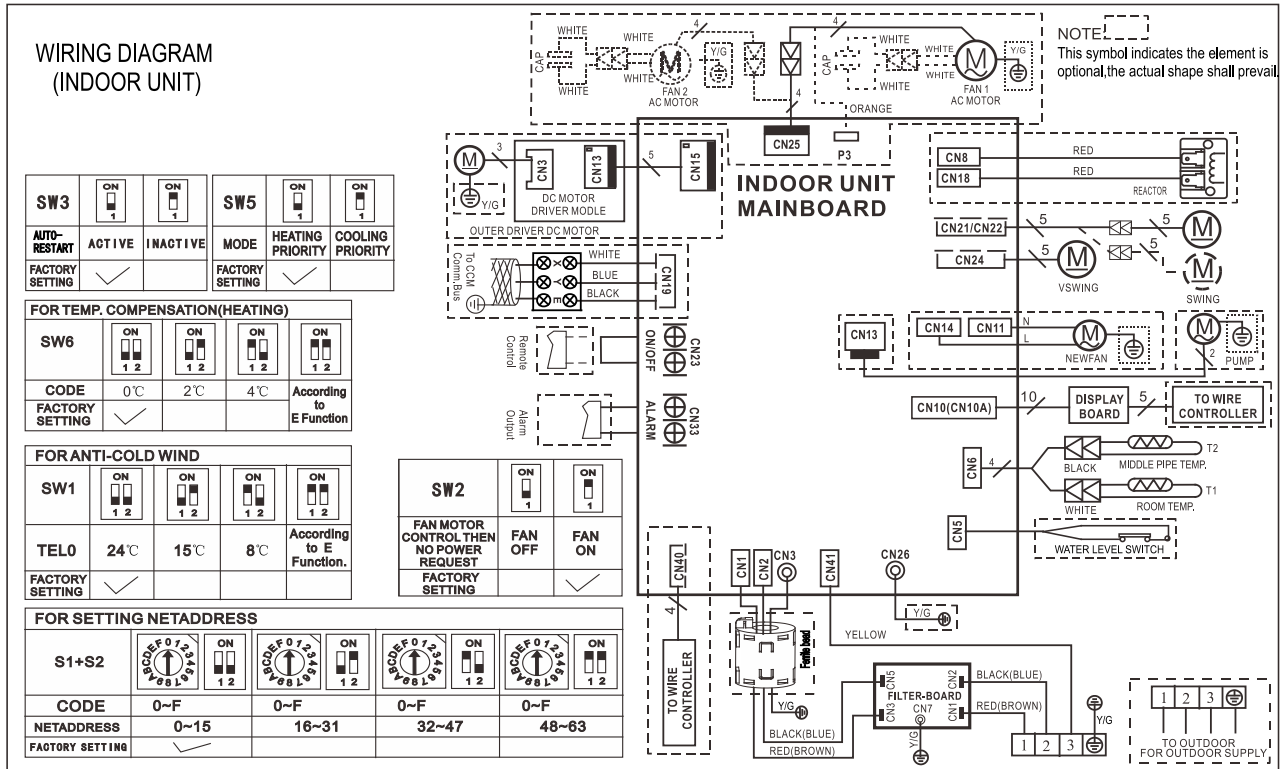

FPA-36DU

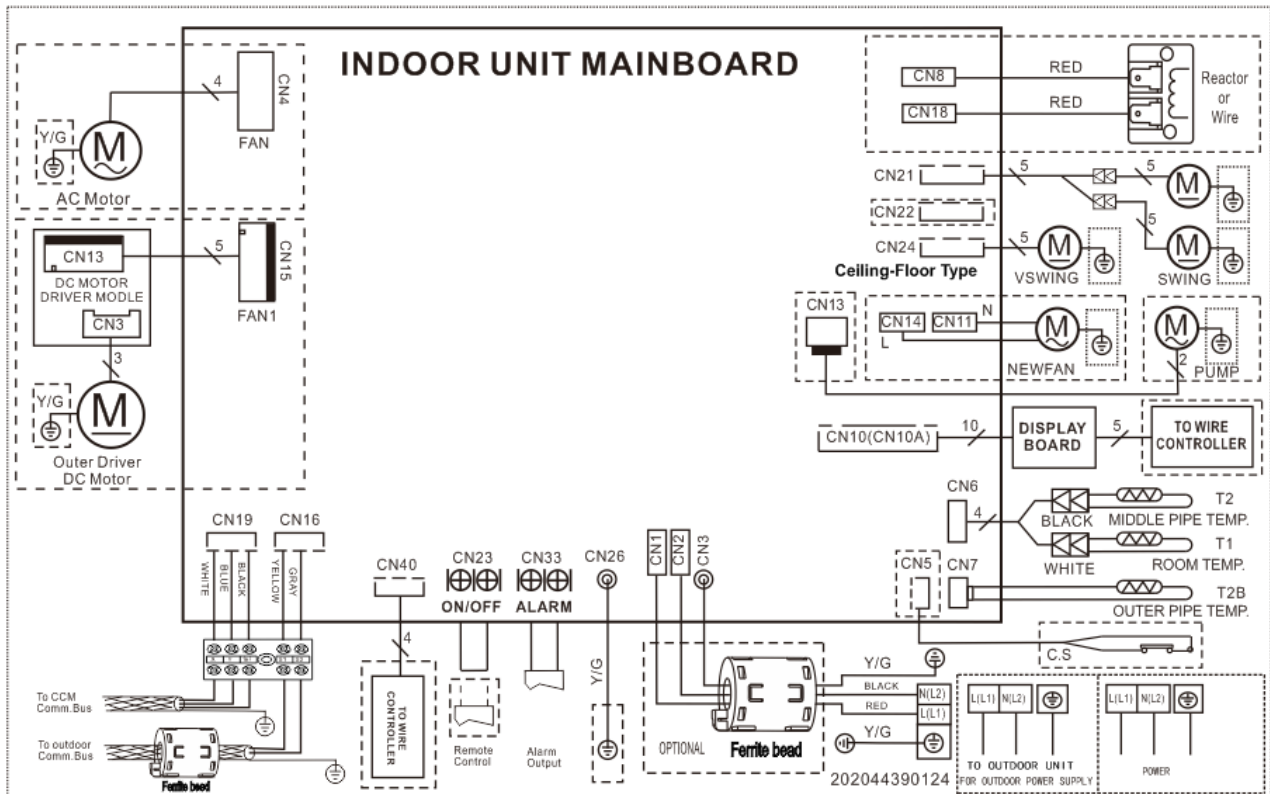

FPA-48DU

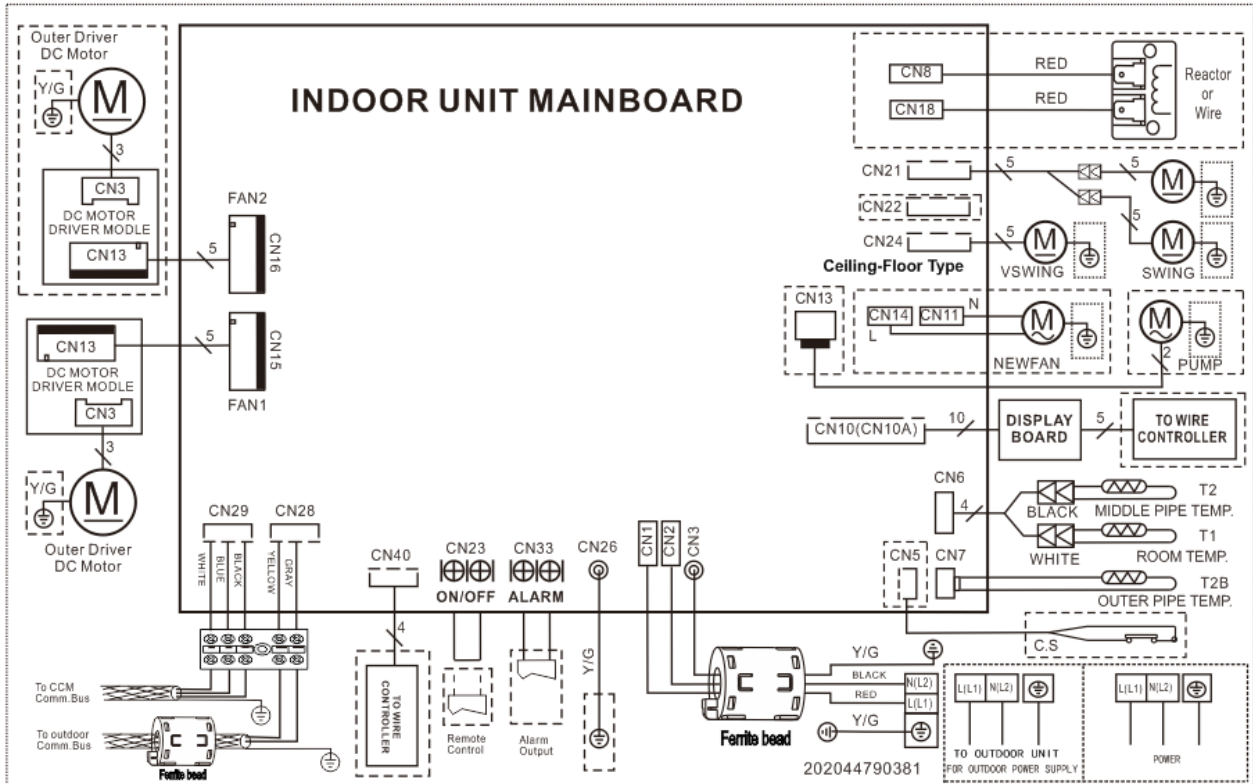

FPA-60DU

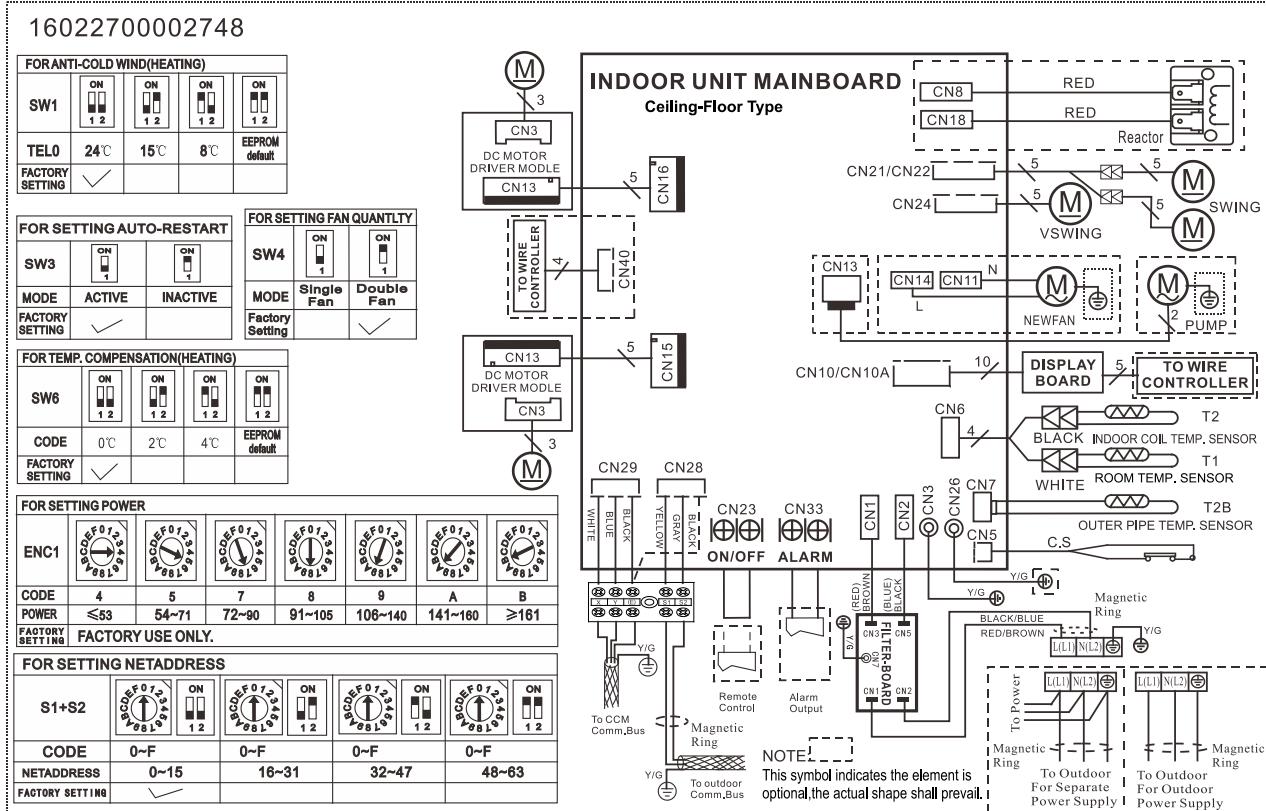

FPA-36DU, FPA-48DU

For Setting NETAddress				
S1+S2				
Code	0~F	00	0~F	01
NETAddress	0~15		16~31	
Factory Setting	✓			

FOR SETTING POWER						
ENC1						
CODE	4	5	7	8	9	A B
POWER	≤53	54~71	72~90	91~105	106~140	141~160 ≥161
FACTORY SETTING	ACCORDING TO RELATED MODEL.					

For temp. compensation				
SW6				
CEILING AND FLOOR TYPE	0°C	2°C	4°C	According to E Function
For Setting CEILING TYPE or FLOOR TYPE	FLOOR TYPE	CEILING TYPE		
Factory Setting	✓			

For Setting Fan Quantity (optional)		
SW4		
Mode	Single Fan	Double Fan
Factory Setting		✓

FOR ANTI-COLD WIND			
SW1			
TELO	24°C	15°C	Fan motor do not stop. According to the E Function.
FACTORY SETTING	✓		

FOR SETTING AUTO-RESTART		
SW3		
AUTO-RESTART	ACTIVE	INACTIVE
FACTORY SETTING	✓	

For Setting Fan Motor Control then No Power Request		
SW2		
Mode	Fan OFF	Fan ON
Factory Setting		✓

FUNCTION SETTING INDICATION
202044690388

CPA-09B, CPA-12B, CPA-18B, CPA-24B

1602300007041
WIRING DIAGRAM
(INDOOR UNIT)

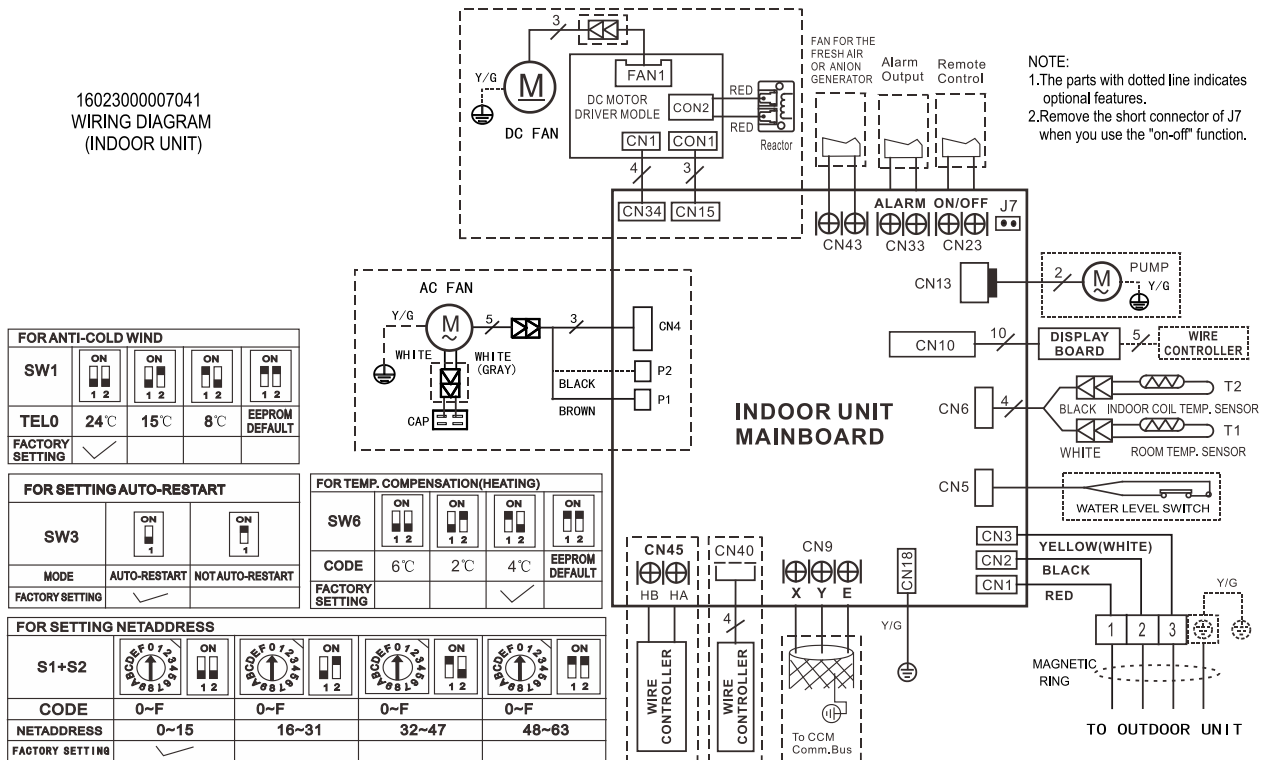

NOTE:
1.The parts with dotted line indicates optional features.
2.Remove the short connector of J7 when you use the "on-off" function.

CPA-36DUB , CPA-48DUB, CPA-60DU

16023000007021 WIRING DIAGRAM

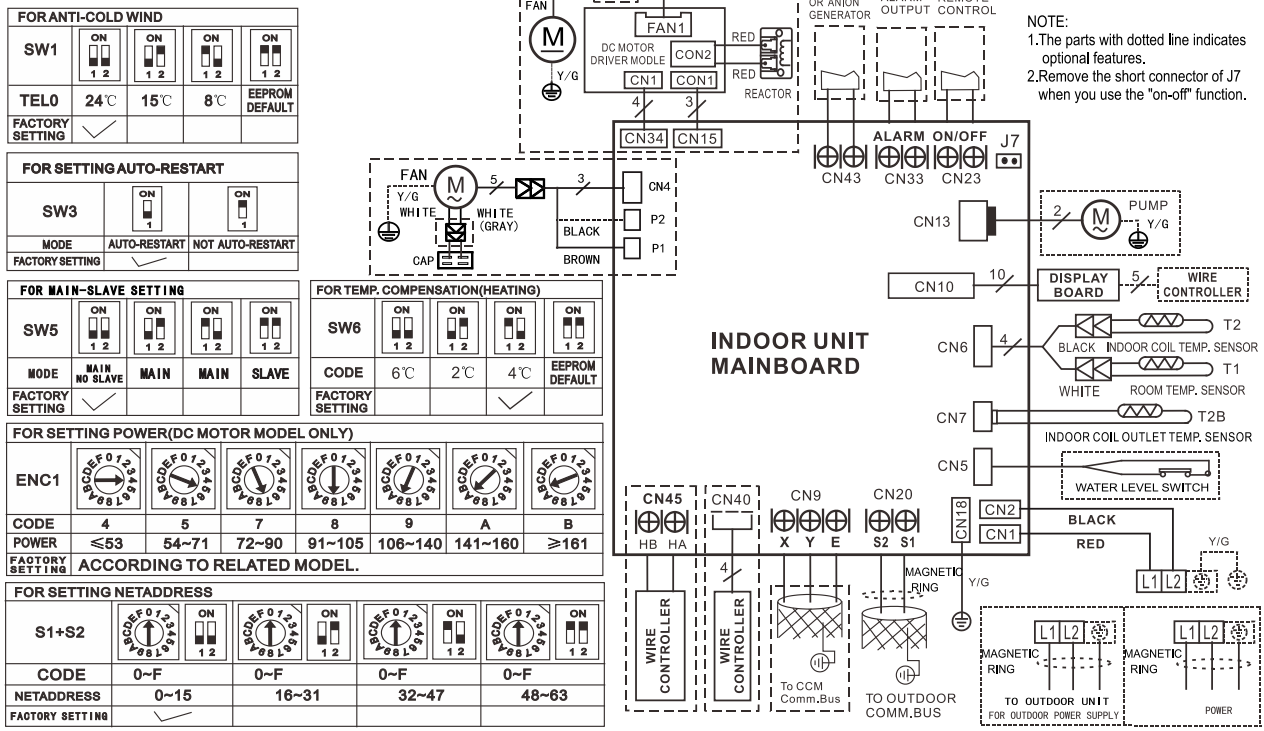

6.1.1 Some connectors introduce:

TPA-09, TPA-12, TPA-18, TIP24, TIP36, TIP48

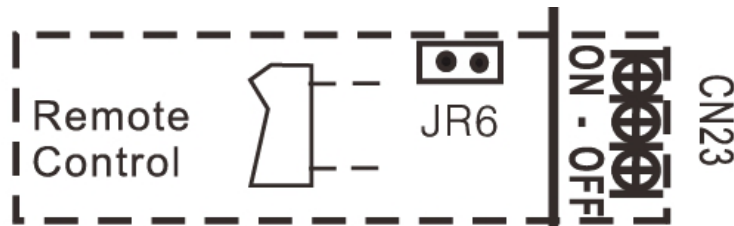

A For remote control (ON-OFF) terminal port CN23 and short connector of JR6

1. Remove the short connector of JR6 when you use ON-OFF function;
2. When remote switch off (OPEN), the unit would be off;
3. When remote switch on (CLOSE), the unit would be on;
4. When close/open the remote switch, the unit would be responded the demand within 2 seconds;
5. When the remote switch on. you can use remote controller/ wire controller to select the mode what you want ;when the remote switch off , the unit would not respond the demand from remote controller/wire controller.

When the remote switch off, but the remote controller / wire controller are on, CP code would be shown on the display board.

6. The voltage of the port is 12V DC , design Max. current is 5mA.

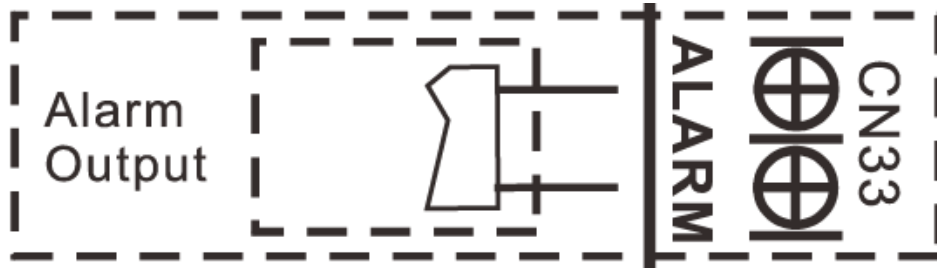
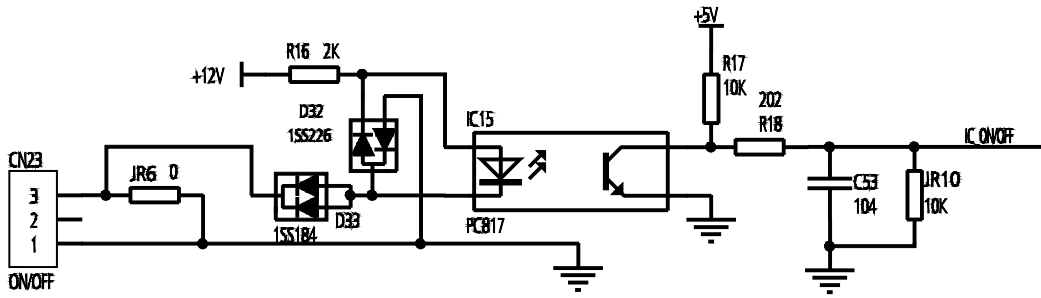

B For ALARM terminal port CN33

1. Provide the terminal port to connect ALARM, but no voltage of the terminal port , the power from the ALARM system (not from the unit)
2. Although design voltage can support higher voltage, but we strongly ask you connect the power less than 24V, current less than 0.5A
3. When the unit occurs the problem, the relay would be closed, then ALARM works

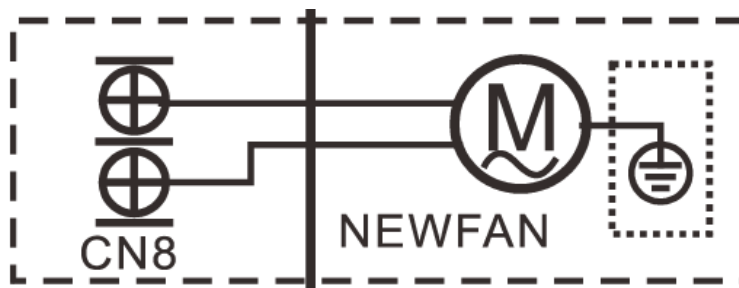
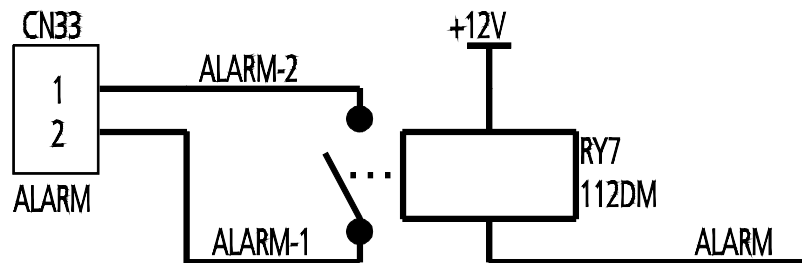

C. For new fresh motor terminal port CN8

1. Connect the fan motor to the port, no need care L/N of the motor;
2. The output voltage is the power supply;
3. The fresh motor cannot excess 200W or 1A, follow the smaller one;

4. The new fresh motor will be worked when the indoor fan motor work ;when the indoor fan motor stops , the new fresh motor would be stopped ;
5. When the unit enter force cooling mode or capacity testing mode, the fresh motor isn't work .

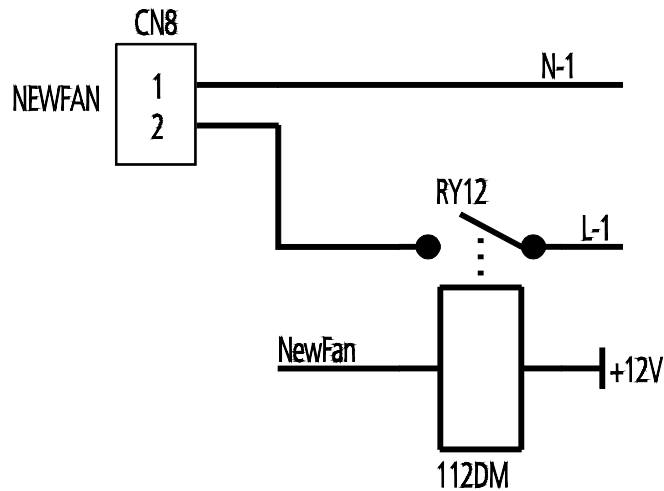

FPA-18, FPA-24, FPA-36DU, FPA-48DU, FPA-60DU

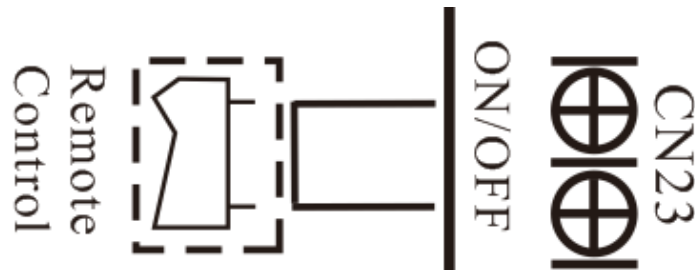

A For remote control (ON-OFF) terminal port CN23

1. Remove the short connector in CN23 when you use ON-OFF function;
2. When remote switch off (OPEN), the unit would be off;
3. When remote switch on (CLOSE), the unit would be on;
4. When close/open the remote switch, the unit would be responded the demand within 2 seconds;
5. When the remote switch on. You can use remote controller/wire controller to select the mode what you want; when the remote switch off, the unit would not respond the demand from remote controller/wire controller.

When the remote switch off, but the remote controller/wire controller are on, CP code would be shown on the display board.

6. The voltage of the port is 12V DC, design Max. current is 5mA.

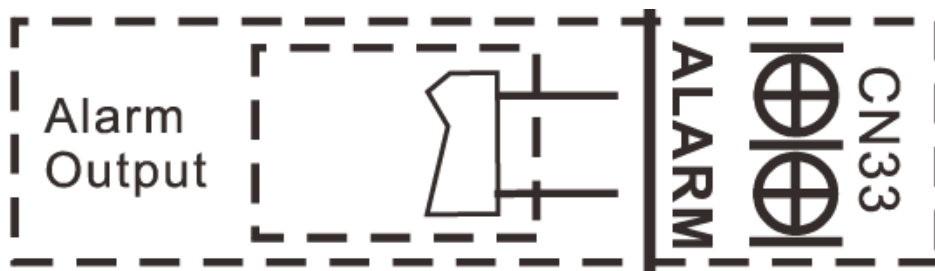
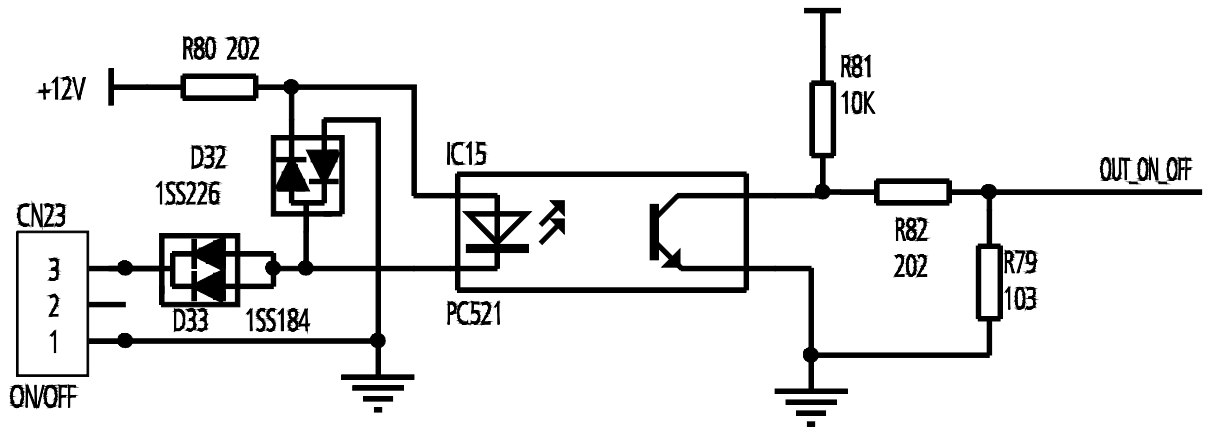

B For ALARM terminal port CN33

1. Provide the terminal port to connect ALARM, but no voltage of the terminal port , the power from the ALARM system (not from the unit)
2. Although design voltage can support higher voltage, but we strongly ask you connect the power less than 24V, current less than 0.5A
3. When the unit occurs the problem, the relay would be closed, then ALARM works

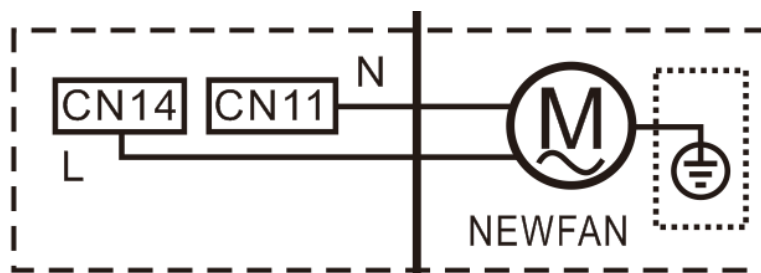
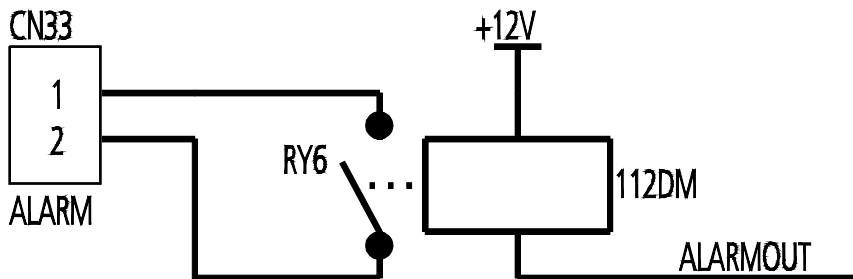

C. For new fresh motor terminal port CN14&CN14

1. Connect the fan motor to the port, no need care L/N of the motor;
2. The output voltage is the power supply;
3. The fresh motor cannot exceed 200W or 1A, follow the smaller one;
4. The new fresh motor will be worked when the indoor fan motor work ;when the indoor fan motor stops, the new fresh motor would be stopped;
5. When the unit enter force cooling mode or capacity testing mode, the fresh motor isn't work.

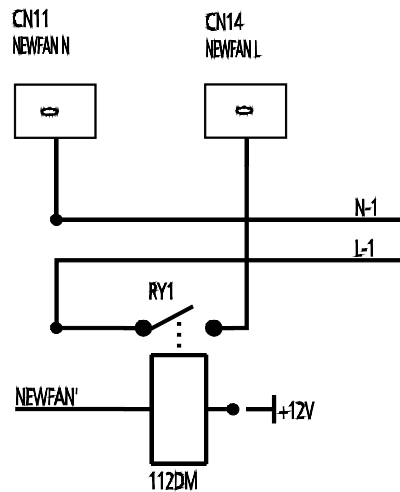

CPA-09B, CPA-12B, CPA-18B, CPA-24B, CPA-36DUB , CPA-48DUB, CPA-60DU

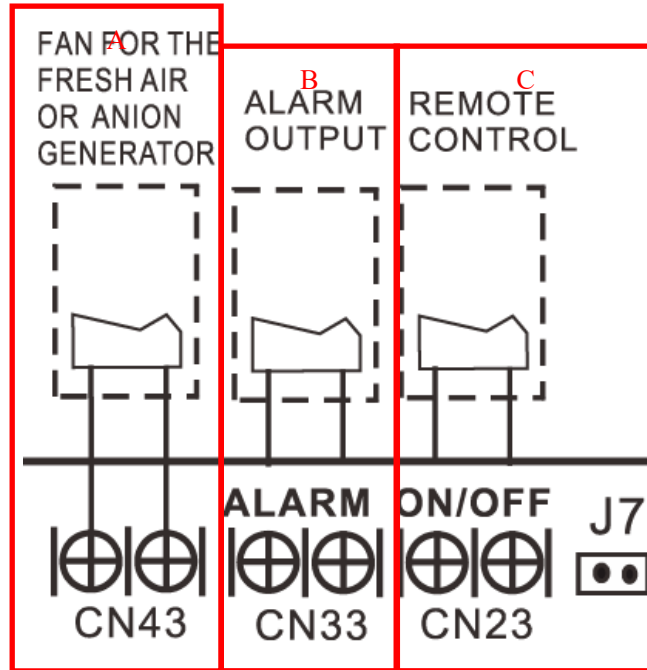

A. For new fresh motor terminal port (also for Anion generator) CN43:

1. Connect the fan motor to the port, no need care L/N of the motor;
2. The output voltage is the power supply;
3. The fresh motor cannot excess 200W or 1A, follow the smaller one;
4. The new fresh motor will be worked when the indoor fan motor work; when the indoor fan motor stops, the new fresh motor would be stopped;
5. When the unit enter force cooling mode or capacity testing mode, the fresh motor isn't work.

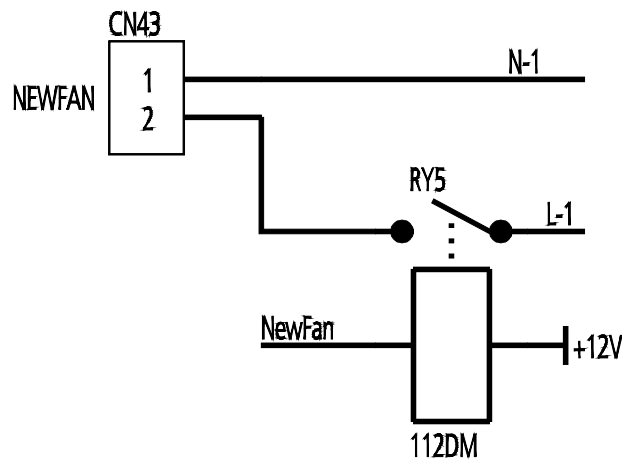

B For ALARM terminal port CN33

1. Provide the terminal port to connect ALARM, but no voltage of the terminal port, the power from the ALARM system (not from the unit)
2. Although design voltage can support higher voltage, but we strongly ask you connect the power less than 24V, current less than 0.5A
3. When the unit occurs the problem, the relay would be closed, then ALARM works

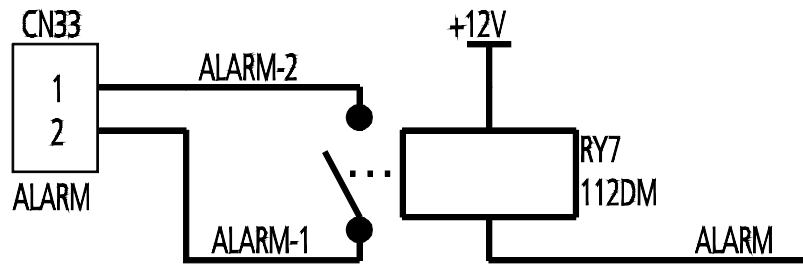

C. For remote control (ON-OFF) terminal port CN23 and short connector of J7

1. Remove the short connector of J7 when you use ON-OFF function;
2. When remote switch off (OPEN), the unit would be off;
3. When remote switch on (CLOSE), the unit would be on;
4. When close/open the remote switch, the unit would be responded the demand within 2 seconds;
5. When the remote switch on. You can use remote controller/wire controller to select the mode what you want; when the remote switch off, the unit would not respond the demand from remote controller/wire controller.

When the remote switch off, but the remote controller / wire controller are on, CP code would be shown on the display board.

6. The voltage of the port is 12V DC, design Max. current is 5mA.

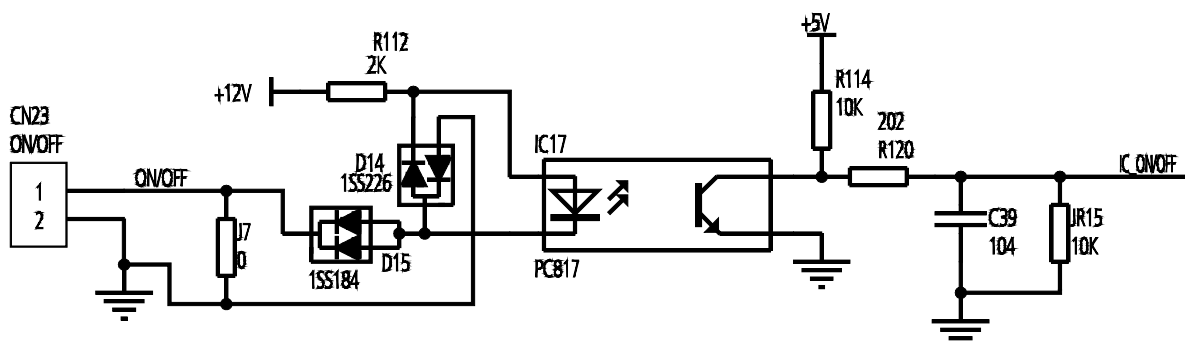

6.1.2 Micro-Switch Introduce:

TPA-09, TPA-12, TPA-18,

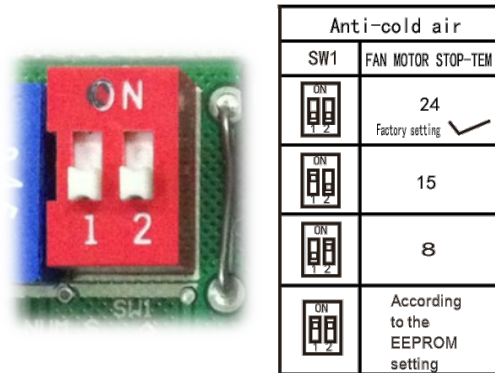

A. Micro-switch SW1 is for selection of indoor fan stop temperature (TEL0) when it is in anti-cold wind action in heating mode.

Range: 24°C, 15°C, 8 °C, according to EEROM setting (reserved for special customizing).

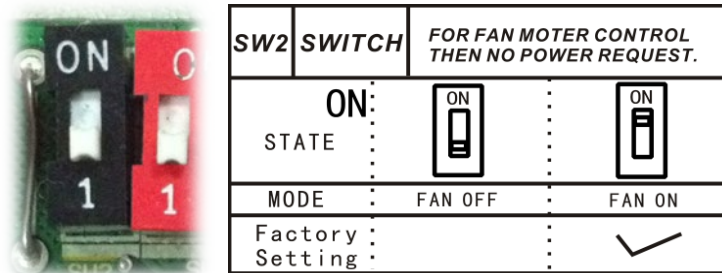
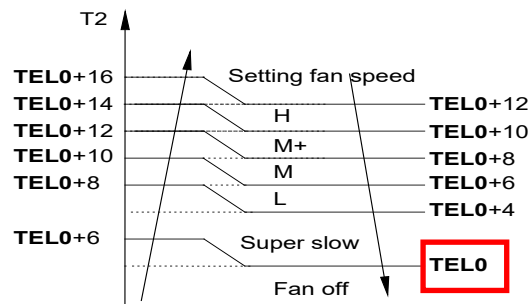

B. Micro-switch SW2 is for selection of indoor FAN ACTION if room temperature reaches the setpoint and the compressor stops.

Range: OFF (in 127s), Keep running.

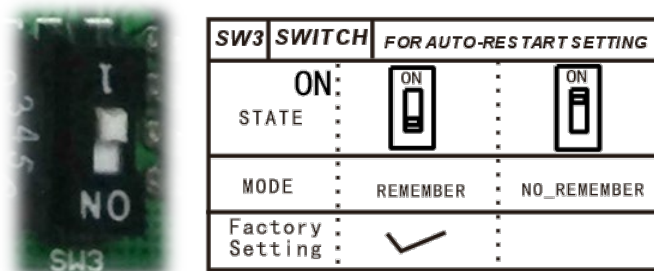

C. Micro-switch SW3 is for selection of auto-restart function.

Range: Active, inactive

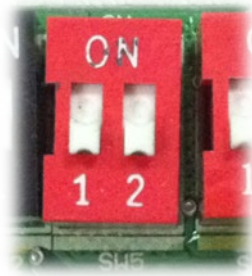

SW5	SWITCH	FOR MODE-PRIOR SETTING			
ON:					
STATE					
MODE		HEAT	HEAT	COOL	COOL
Factory Setting		✓			

D. Micro-switch SW5 is for setting mode priority of multi connection.

Range: Heat, cool.

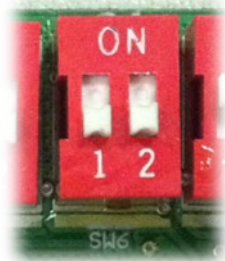

SW6	SWITCH	FOR TEMP. COMPENSATION			
ON:					
STATE					
VALUE		6	4	2	E function
Factory Setting		✓			

E. Micro-switch SW6 is for selection of temperature compensation in heating mode. This helps to reduce the real temperature difference between ceiling and floor so that the unit could run properly. If the height of installation is lower, smaller value could be chosen.

Range: 6°C, 4°C, 2°C, E function (reserved for special customizing)

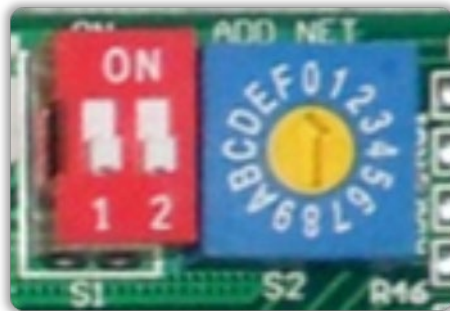

SWITCH		FOR CCM UNIT ADDRESS			
S2 + S1					
ADDRESS		0~15		16~31	
Factory Setting		✓			
S2 + S1					
ADDRESS		32~47		48~63	
Factory Setting					

F. Micro-switch S1 and dial-switch S2 are for address setting when you want to control this unit by a central controller.

Range: 00-63

TIP24, TIP36, TIP48

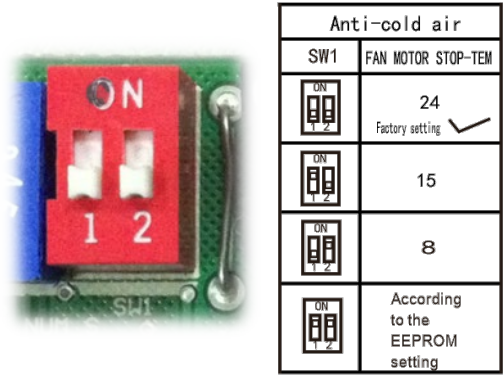

A. Micro-switch SW1 is for selection of indoor fan stop temperature (TEL0) when it is in anti-cold wind action in heating mode.

Range: 24°C, 15°C, 8°C, according to EEROM setting (reserved for special customizing).

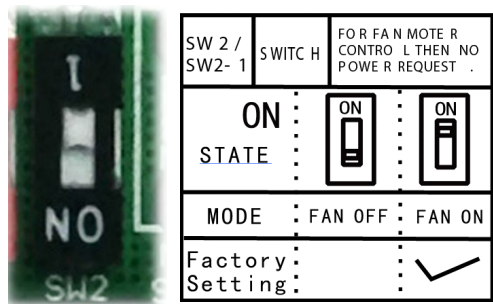
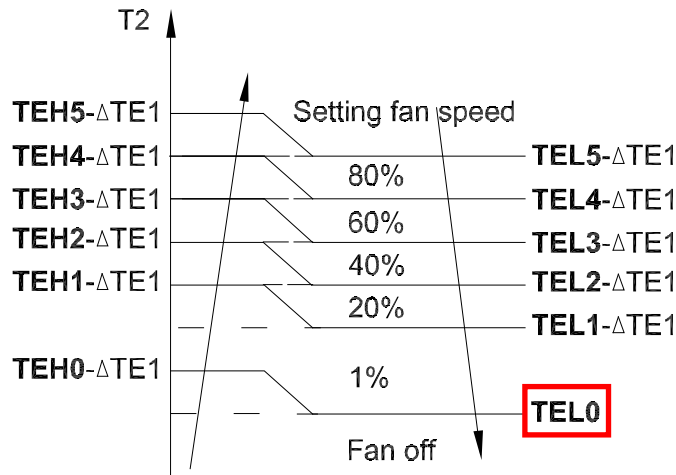

B. Micro-switch SW2/SW2-1 is for selection of indoor FAN ACTION if room temperature reaches the setpoint and the compressor stops.

Range: OFF (anti-cold wind is available in heating mode), keep running (No anti-cold wind function).

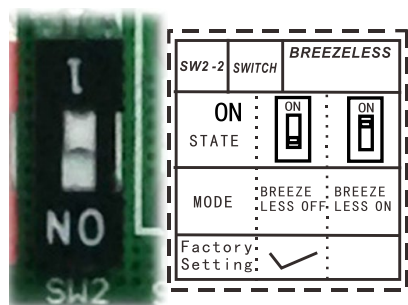

C. Micro-switch SW2-2 is for selection of Breezeless function.

Range: OFF, ON.

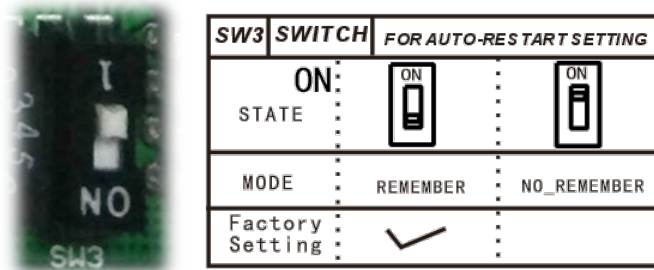

D. Micro-switch SW3 is for selection of auto-restart function.

Range: Active, inactive

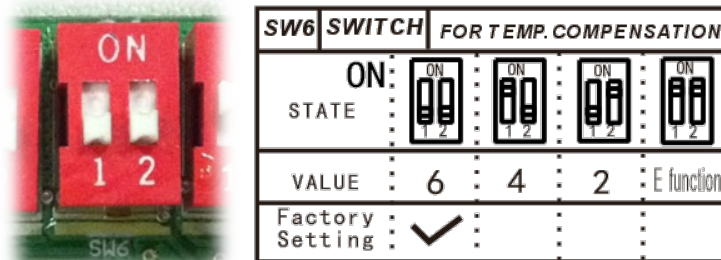

E. Micro-switch SW6 is for selection of temperature compensation in heating mode. This helps to reduce the real temperature difference between ceiling and floor so that the unit could run properly. If the height of installation is lower, smaller value could be chosen.

Range: 6°C, 4°C, 2°C, E function (reserved for special customizing)

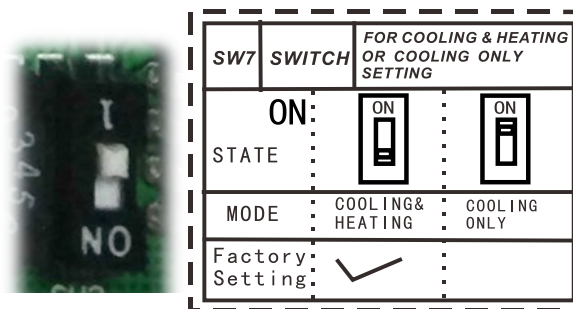

F. Micro-switch SW7 is for setting cooling & heating or cooling only.

Range: cooling & heating, cooling.

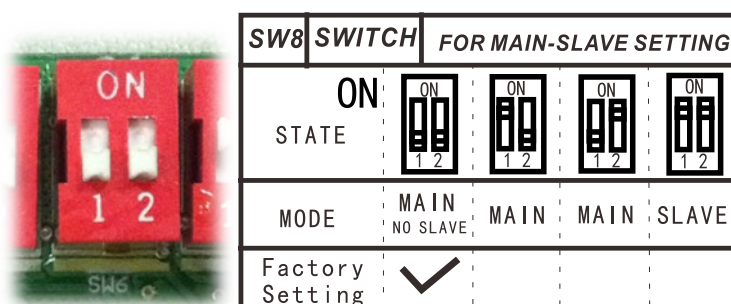

G. Micro-switch SW8 is for setting the master or slave unit when the unit is in twin connection.

Range: Master no slave (Normal 1 drive 1 connection), Master (2 positions without difference), Slave

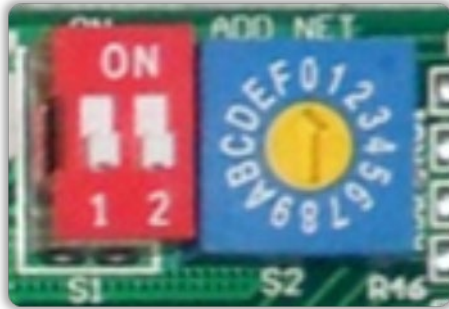

SWITCH		FOR CCM UNIT ADDRESS	
S2 + S1			
ADDRESS	0~15	16~31	
Factory Setting	✓		
S2 + S1			
ADDRESS	32~47	48~63	
Factory Setting			

H. Micro-switch S1 and dial-switch S2 are for address setting when you want to control this unit by a central controller.

Range: 00-63



FOR SETTING POWER(DC MOTOR MODEL ONLY)										
ENC1										
CODE	0	1	2	4	5	7	8	9	A	B
POWER	20	26	32~35	36~53	54~71	72~90	91~105	106~140	141~160	161~200
FACTORY SETTING	ACCORDING TO RELATED MODEL.									

I. Dial-switch ENC1: The indoor PCB is universal designed for whole series units from 7K to 68K. This ENC1 setting will tell the main program what size the unit is.

NOTE: Usually there is glue on it because the switch position cannot be changed at random unless you want to use this

PCB as a spare part to use in another unit. Then you have to select the right position to match the size of the unit.

“20” means 2kW (7K), “105” means 10.5kW(36K), and so on.

FPA-18, FPA-24

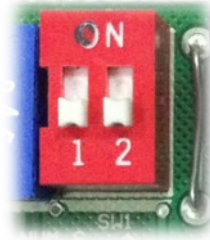

FOR ANTI-COLD WIND				
SW1				
TELO	24°C	15°C	8°C	According to E Function.
FACTORY SETTING	✓			

A. Micro-switch SW1 is for selection of indoor fan stop temperature (TELO) when it is in anti-cold wind action in heating mode.

Range: 24°C, 15°C, 8°C, According to EEROM setting (reserved for special customizing).

For FPA-24:

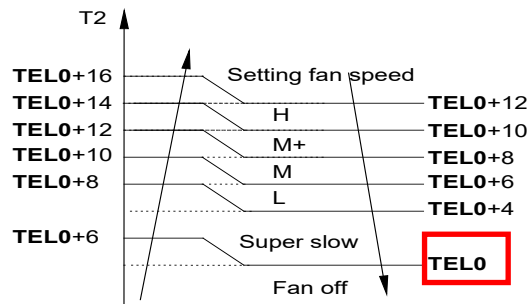

For FPA-18:

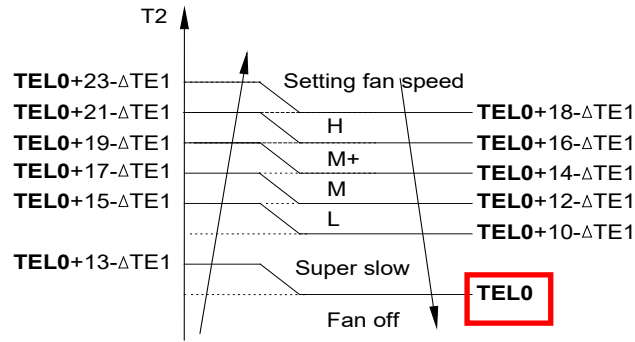

SW2		
FAN MOTOR CONTROL THEN NO POWER REQUEST	FAN OFF	FAN ON
FACTORY SETTING		✓

B. Micro-switch SW2 is for selection of indoor FAN ACTION if room temperature reaches the setpoint and the compressor stops.

Range: OFF (in 127s), Keep running.



FOR SETTING AUTO-RESTART		
SW3		
AUTO-RESTART	ACTIVE	INACTIVE
FACTORY SETTING	✓	

C. Micro-switch SW3 is for selection of auto-restart function.

Range: Active, inactive



SW5		
MODE	HEATING PRIORITY	COOLING PRIORITY
FACTORY SETTING	✓	

D. Micro-switch SW5 is for setting mode priority of multi connection.

Range: Heat, cool.



FOR SETTING TEMP. COMPENSATION(HEATING)				
SW6				
CODE	0°C	2°C	4°C	According to E function
FACTORY SETTING	✓			

E. Micro-switch SW6 is for selection of temperature compensation in heating mode. This helps to reduce the real temperature difference between ceiling and floor so that the unit could run properly. If the unit is on-floor installed, 0 should be chosen.

Range: 0°C, 2°C, 4°C, E function (reserved for special customizing)

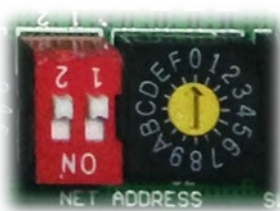

FOR SETTING NETADDRESS				
S1+S2				
CODE	0~F	0~F	0~F	0~F
NETADDRESS	0~15	16~31	32~47	48~63
FACTORY SETTING	✓			

F. Micro-switch S1 and dial-switch S2 are for address setting when you want to control this unit by a central controller.

Range: 00-63

FPA-36DU, FPA-48DU

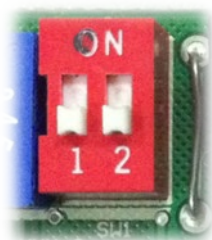

FOR ANTI-COLD WIND				
SW1				
TELO	24°C	15°C	Fan motor do not stop.	According to the EFunction.
FACTORY SETTING	✓			

A. Micro-switch SW1 is for selection of indoor fan stop temperature (TELO) when it is in anti-cold wind action in heating mode.

Range: 24°C, 15°C, Fan motor do not stop, According to EEROM setting (reserved for special customizing).

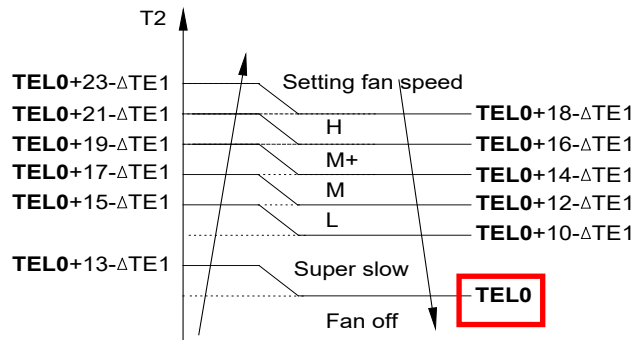

For Setting Fan Motor Control then No Power Request		
SW2		
Mode	Fan OFF	Fan ON
Factory Setting		✓

B. Micro-switch SW2 is for selection of indoor FAN ACTION if room temperature reaches the setpoint and the compressor stops.

Range: OFF (in 127s), Keep running.



FOR SETTING AUTO-RESTART		
SW3		
AUTO-RESTART	ACTIVE	INACTIVE
FACTORY SETTING	✓	

C. Micro-switch SW3 is for selection of auto-restart function.

Range: Active, inactive



For Setting Fan Quantity		
SW4		
Mode	Single Fan	Double Fan
Factory Setting		✓

D. Micro-switch SW4 is for selection of quantity of fan motors. Same as size selection switch, this switch is for making the PCB suitable for all series units. DO NOT change it at random unless you want to use the PCB as a spare part

Range: Single Fan, Double Fan

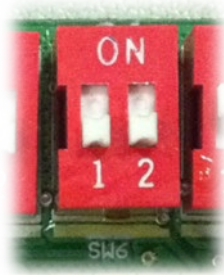

For temp. compensation			
SW6			
CEILING AND FLOOR TYPE	0°C	2°C	4°C
For Setting CEILING TYPE or FLOOR TYPE	FLOOR TYPE	CEILING TYPE	According to E Function
Factory Setting	✓		

E. Micro-switch SW6 is for selection of temperature compensation in heating mode. This helps to reduce the real temperature difference between ceiling and floor so that the unit could run properly. If the unit is on-floor installed, 0 should be chosen.

Range: 0°C, 2°C, 4°C, E function (reserved for special customizing)

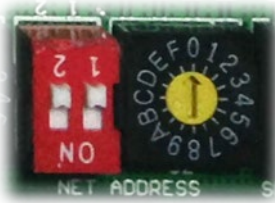

FOR SETTING NETADDRESS			
S1+S2			
CODE	0~F	0~F	0~F
NETADDRESS	0~15	16~31	32~47
FACTORY SETTING	✓		

F. Micro-switch S1 and dial-switch S2 are for address setting when you want to control this unit by a central controller.

Range: 00-63

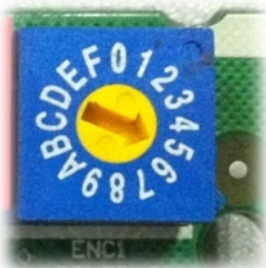

FOR SETTING POWER(FACTORY USE ONLY)						
ENC1						
CODE	4	5	7	8	9	A
POWER	≤53	54~71	72~90	91~105	106~140	141~160
FACTORY SETTING	ACCORDING TO RELATED MODEL.					





G. Dial-switch ENC1: The indoor PCB is universal designed for whole series units from 18K to 55K. This ENC1 setting will tell the main program what size the unit is.

NOTE: Usually there is glue on it because the switch position cannot be changed at random unless you want to use this PCB as a spare part to use in another unit. Then you have to select the right position to match the size of the unit.

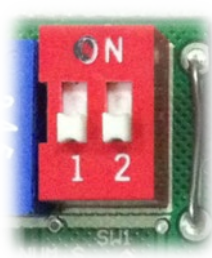
“53” means 5.3kW (18K), “105” means 10.5kW(36K), and so on.



FPA-60DU



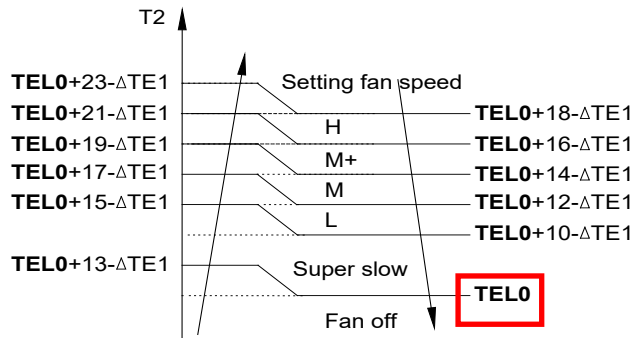

FOR ANTI-COLD WIND				
SW1				
TELO	24°C	15°C	8°C	EEPROM DEFAULT
FACTORY SETTING	✓			

A. Micro-switch SW1 is for selection of indoor fan stop temperature (TELO) when it is in anti-cold wind action in heating mode.

Range: 24°C, 15°C, 8°C , According to EEROM setting (reserved for special customizing).





FOR SETTING AUTO-RESTART		
SW3		
AUTO-RESTART	ACTIVE	INACTIVE
FACTORY SETTING	✓	

B. Micro-switch SW3 is for selection of auto-restart function.

Range: Active, inactive



For Setting Fan Quantity		
SW4		
Mode	Single Fan	Double Fan
Factory Setting		✓

C. Micro-switch SW4 is for selection of quantity of fan motors. Same as size selection switch, this switch is for making the PCB suitable for all series units. DO NOT change it at random unless you want to use the PCB as a spare part

Range: Single fan, double fan

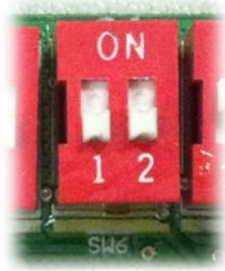

FOR TEMP. COMPENSATION(HEATING)				
SW6				
CODE	0°C	2°C	4°C	EEPROM default
FACTORY SETTING	✓			

D. Micro-switch SW6 is for selection of temperature compensation in heating mode. This helps to reduce the real temperature difference between ceiling and floor so that the unit could run properly. If the unit is on-floor installed, 0 should be chosen.

Range: 0°C, 2°C, 4°C, E function (reserved for special customizing)

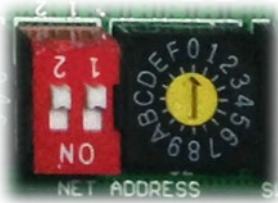

FOR SETTING NETADDRESS				
S1+S2				
CODE	0~F	0~F	0~F	0~F
NETADDRESS	0~15	16~31	32~47	48~63
FACTORY SETTING	✓			

E. Micro-switch S1 and dial-switch S2 are for address setting when you want to control this unit by a central controller.

Range: 00-63



FOR SETTING POWER(FACTORY USE ONLY)							
ENC1							
CODE	4	5	7	8	9	A	B
POWER	≤53	54~71	72~90	91~105	106~140	141~160	≥161
FACTORY SETTING	ACCORDING TO RELATED MODEL.						

F. Dial-switch ENC1: The indoor PCB is universal designed for whole series units from 18K to 55K. This ENC1 setting will tell the main program what size the unit is.

NOTE: Usually there is glue on it because the switch position cannot be changed at random unless you want to use this PCB as a spare part to use in another unit. Then you have to select the right position to match the size of the unit.

“53” means 5.3kW (18K), “105” means 10.5kW(36K), and so on.

CPA-09B, CPA-12B, CPA-18B, CPA-24B

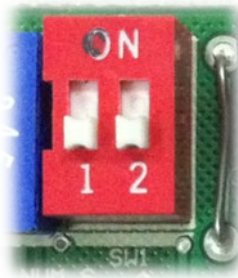

FOR ANTI-COLD WIND				
SW1				
TELO	24°C	15°C	8°C	EEPROM DEFAULT
FACTORY SETTING	✓			

A. Micro-switch SW1 is for selection of indoor fan stop temperature (TELO) when it is in anti-cold wind action in heating mode.

Range: 24°C, 15°C, 8°C, according to EEROM setting (reserved for special customizing).

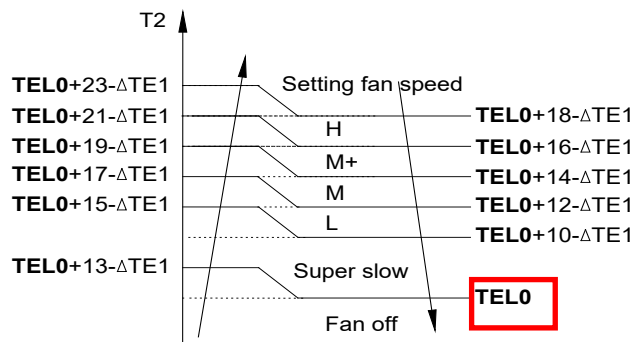

FOR SETTING AUTO-RESTART		
SW3		
MODE	AUTO-RESTART	NOT AUTO-RESTART
FACTORY SETTING	✓	

B. Micro-switch SW3 is for selection of auto-restart function.

Range: Active, inactive

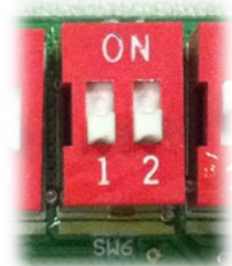

FOR TEMP. COMPENSATION(HEATING)				
SW6				
CODE	6°C	2°C	4°C	EEPROM DEFAULT
FACTORY SETTING			✓	

C. Micro-switch SW6 is for selection of temperature compensation in heating mode. This helps to reduce the real temperature difference between ceiling and floor so that the unit could run properly. If the height

of installation is lower, smaller value could be chosen.

Range: 6°C, 4°C, 2°C, E function (reserved for special customizing)

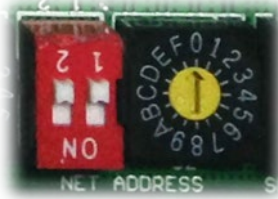

FOR SETTING NETADDRESS				
S1+S2				
CODE	0~F	0~F	0~F	0~F
NETADDRESS	0~15	16~31	32~47	48~63
FACTORY SETTING	<input checked="" type="checkbox"/>			

D. Micro-switch S1 and dial-switch S2 are for address setting when you want to control this unit by a central controller.

Range: 00-63

CPA-36DUB , CPA-48DUB, CPA-60DU

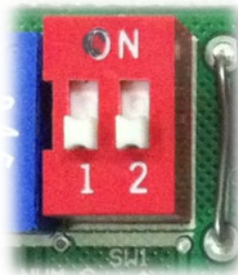

FOR ANTI-COLD WIND				
SW1				
TELO	24°C	15°C	8°C	EEPROM DEFAULT
FACTORY SETTING	<input checked="" type="checkbox"/>			

A. Micro-switch SW1 is for selection of indoor fan stop temperature (TELO) when it is in anti-cold wind action in heating mode.

Range: 24°C, 15°C, 8°C, according to EEROM setting (reserved for special customizing).

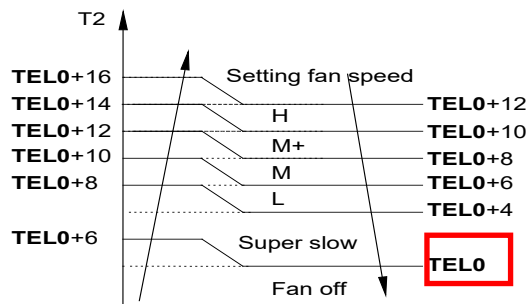



FOR SETTING AUTO-RESTART		
SW3		
MODE	AUTO-RESTART	NOT AUTO-RESTART
FACTORY SETTING	<input checked="" type="checkbox"/>	

B. Micro-switch SW3 is for selection of auto-restart function.

Range: Active, inactive

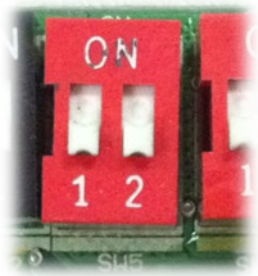

FOR MAIN-SLAVE SETTING				
SW5				
MODE	MAIN NO SLAVE	MAIN	MAIN	SLAVE
FACTORY SETTING	<input checked="" type="checkbox"/>			

C. Micro-switch SW5 is for setting the master or slave unit when the unit is in twin connection.

Range: Master no slave (Normal 1 drive 1 connection), Master (2 positions without difference), Slave

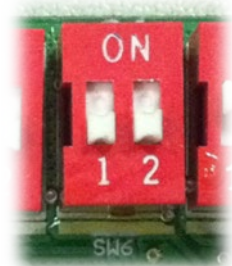

FOR TEMP. COMPENSATION(HEATING)				
SW6				
CODE	6°C	2°C	4°C	EEPROM DEFAULT
FACTORY SETTING			<input checked="" type="checkbox"/>	

D. Micro-switch SW6 is for selection of temperature compensation in heating mode. This helps to reduce the real temperature difference between ceiling and floor so that the unit could run properly. If the height of installation is lower, smaller value could be chosen.

Range: 6°C, 4°C, 2°C, E function (reserved for special customizing)

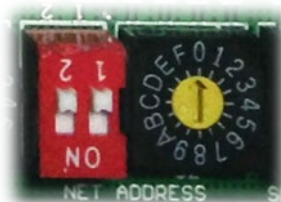

FOR SETTING NETADDRESS				
S1+S2				
CODE	0~F	0~F	0~F	0~F
NETADDRESS	0~15	16~31	32~47	48~63
FACTORY SETTING	✓			

E. Micro-switch S1 and dial-switch S2 are for address setting when you want to control this unit by a central controller.

Range: 00-63

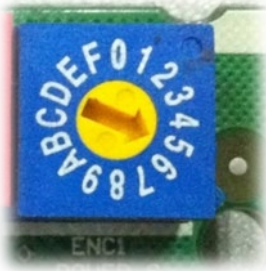

FOR SETTING POWER(FACTORY USE ONLY)							
ENC1							
CODE	4	5	7	8	9	A	B
POWER	≤53	54~71	72~90	91~105	106~140	141~160	≥161
FACTORY SETTING	ACCORDING TO RELATED MODEL.						

F. Dial-switch ENC1: The indoor PCB is universal designed for whole series units from 18K to 55K. This ENC1 setting will tell the main program what size the unit is.

NOTE: Usually there is glue on it because the switch position cannot be changed at random unless you want to use this PCB as a spare part to use in another unit. Then you have to select the right position to match the size of the unit.

“53” means 5.3kW (18K), “105” means 10.5kW(36K), and so on.

6.2 Outdoor Unit

CZP09CD(O), CZP12CD(O), CHF09CD(O), CHF12CD(O)

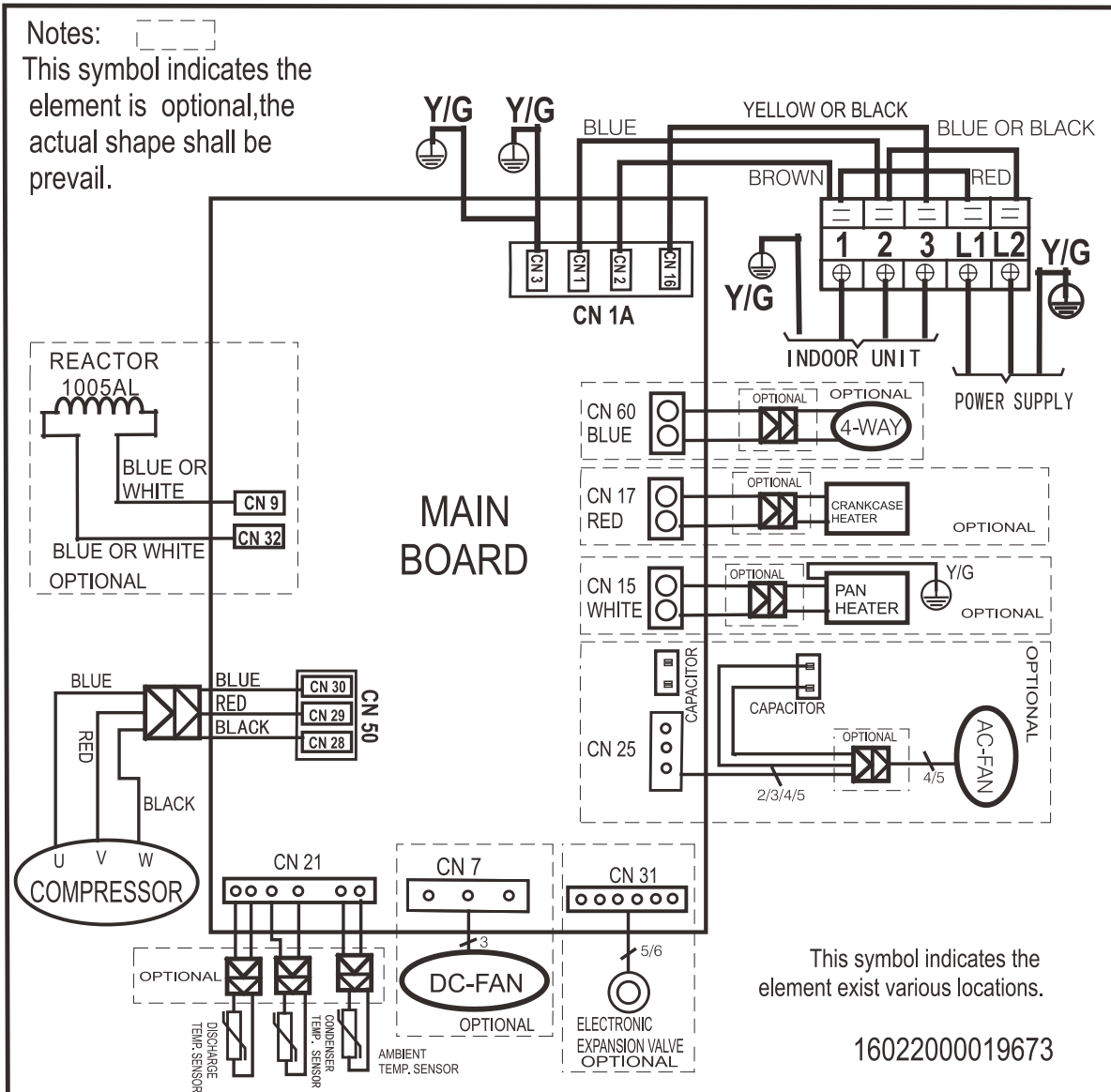

WIRING DIAGRAM

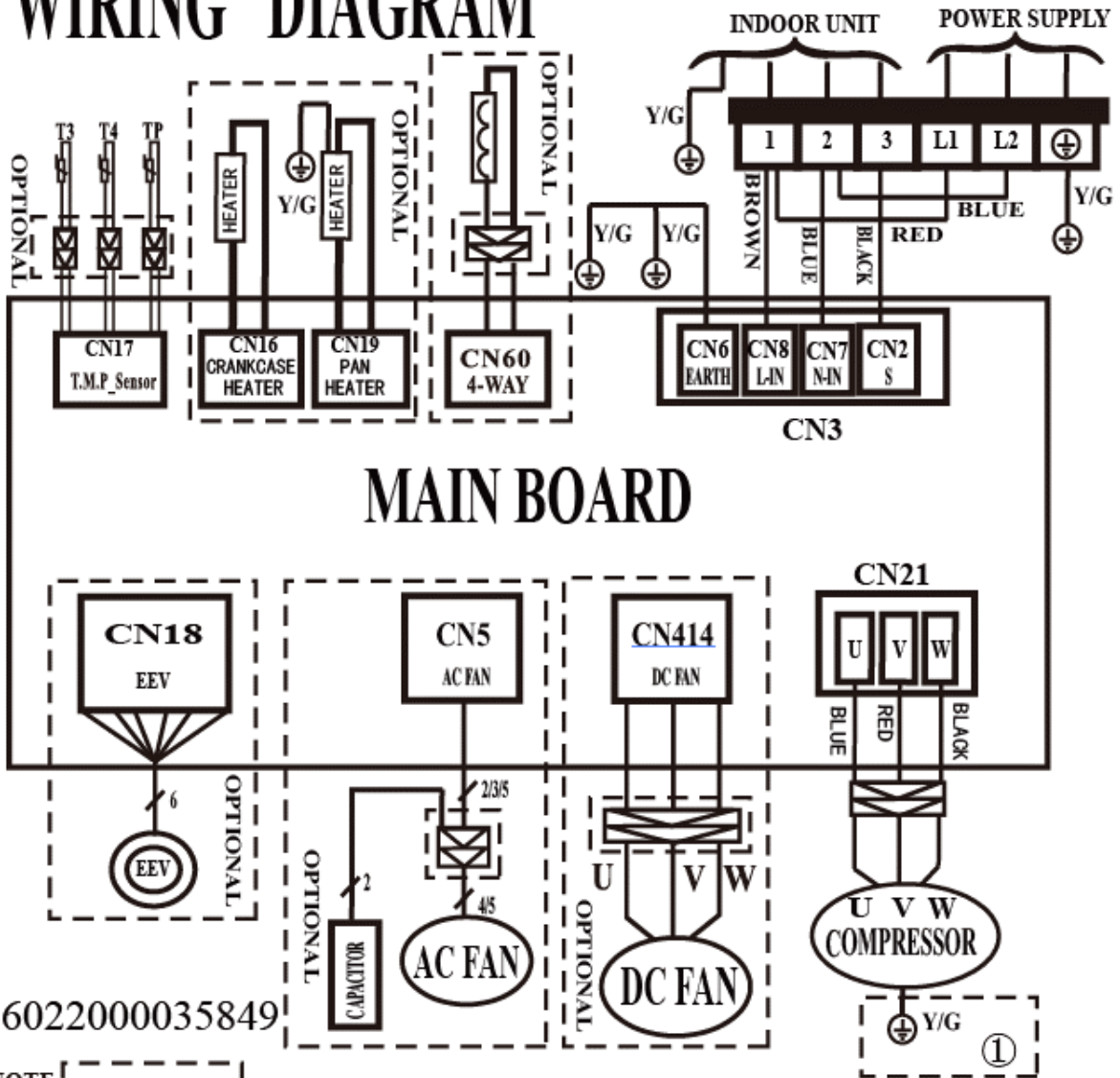

16022000035849

NOTE

This symbol indicates the element is optional, the actual shape shall be prevail.

① The D box contains the ground wire of the compressor, and the other boxes do not.

CHF24CD(O)

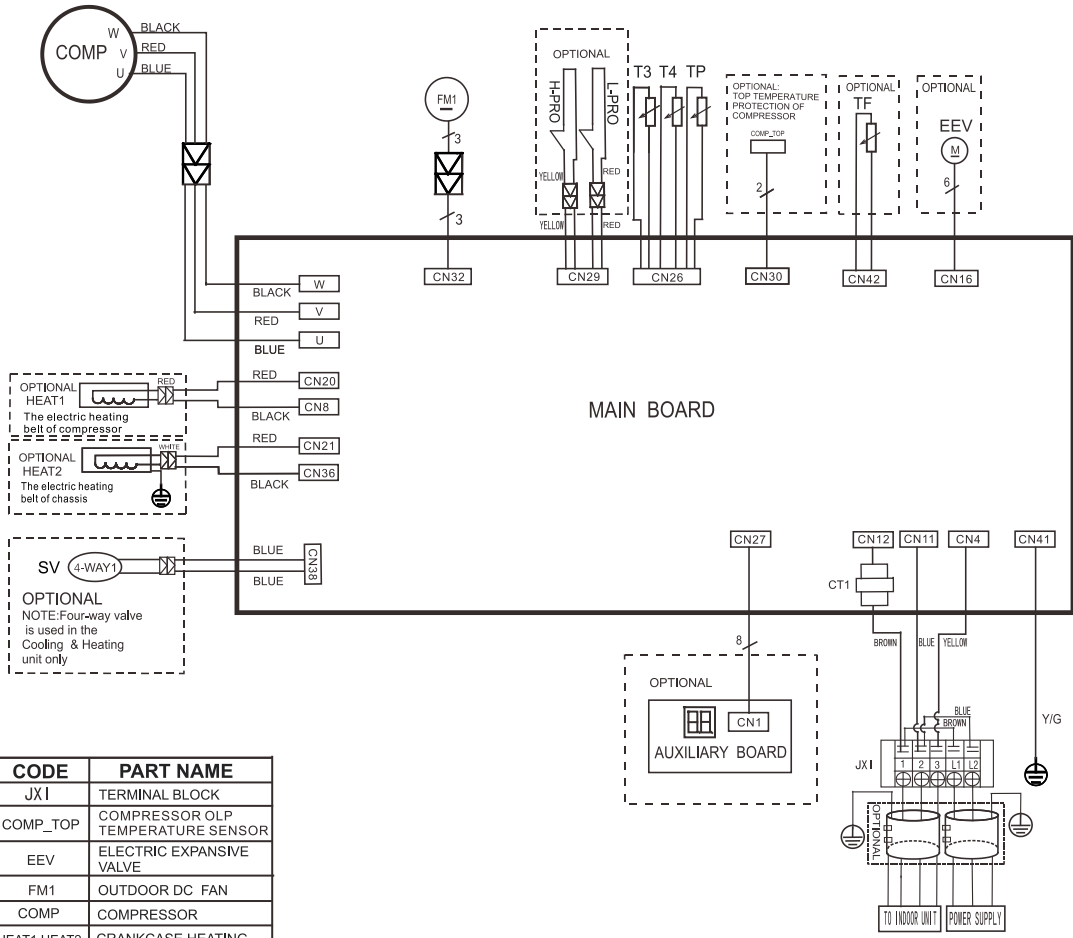

CODE	PART NAME
JX1	TERMINAL BLOCK
COMP_TOP	COMPRESSOR OLP TEMPERATURE SENSOR
EEV	ELECTRIC EXPANSIVE VALVE
FM1	OUTDOOR DC FAN
COMP	COMPRESSOR
HEAT1,HEAT2	CRANKCASE HEATING
CT1	AC CURRENT DETECTOR
H-PRO	HIGH PRESSURE SWITCH
L-PRO	LOW PRESSURE SWITCH
SV	4-WAY VALVE
TP	EXHAUST TEMPERATURE SENSOR
T3	CONDENSER TEMPERATURE SENSOR
T4	OUTDOOR AMBIENT TEMPERATURE SENSOR
TF	TUBE FOR HEATSINK TEMPERATURE SENSOR

Notes:
 This symbol indicates the element is optional, the actual shape shall be prevail.

16022000034529

CHF36CD(O), CHF48CD(O)

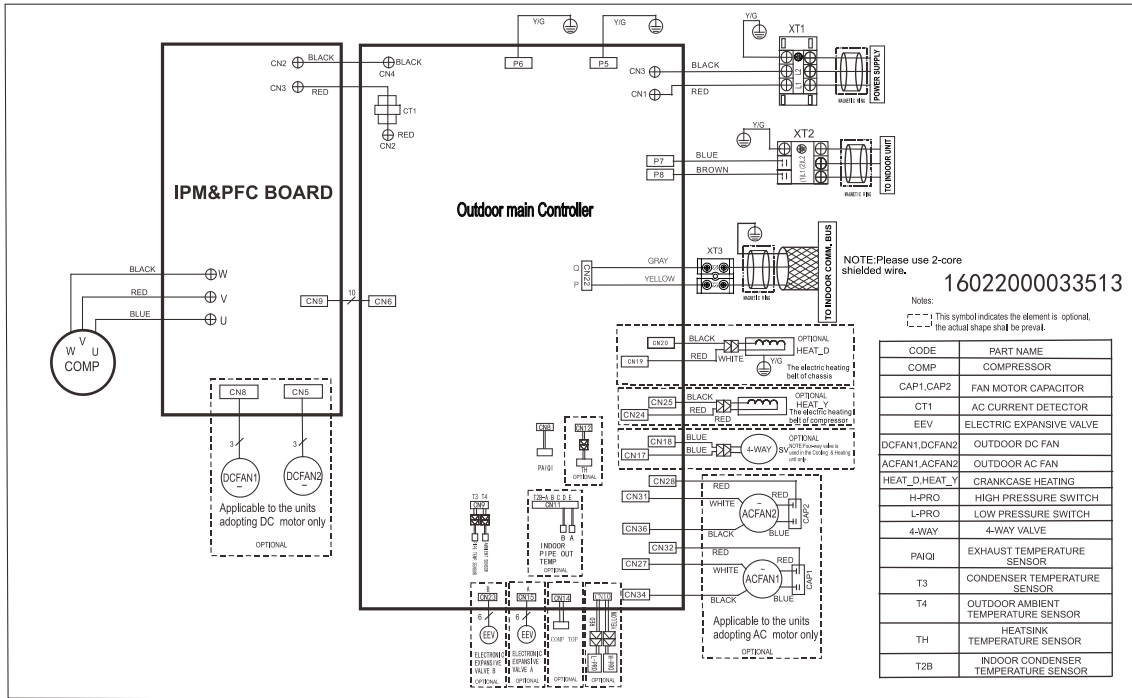

CZP36CD(O)

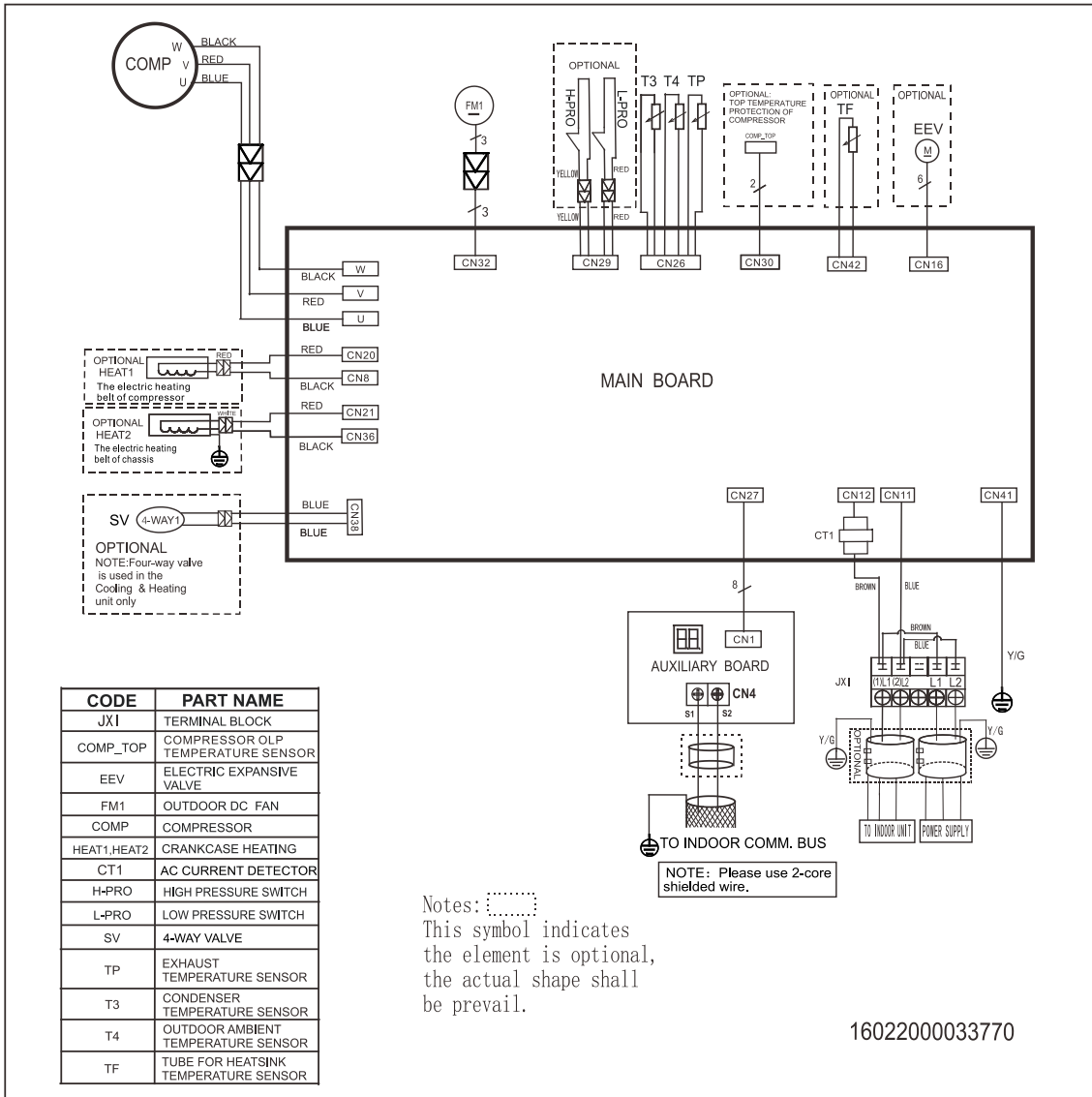

CZP48CD(O), CZP60CD(O)

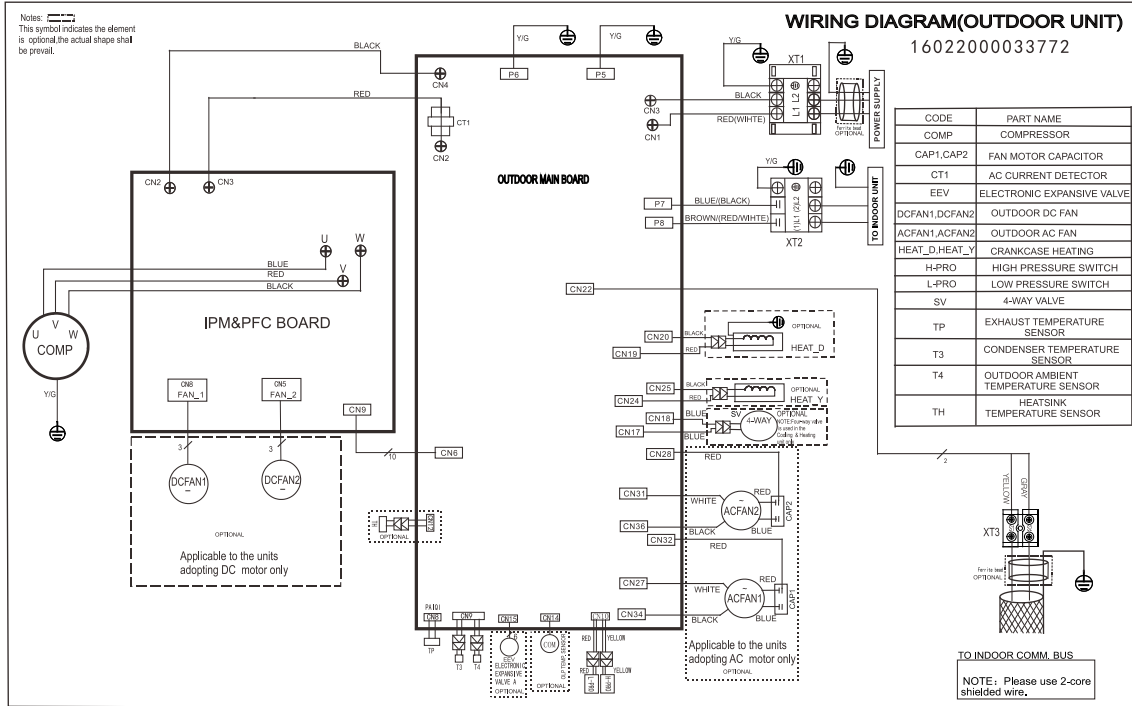

**PCB board of CZP09CD(O), CZP12CD(O), CHF09CD(O)
CHF12CD(O)**

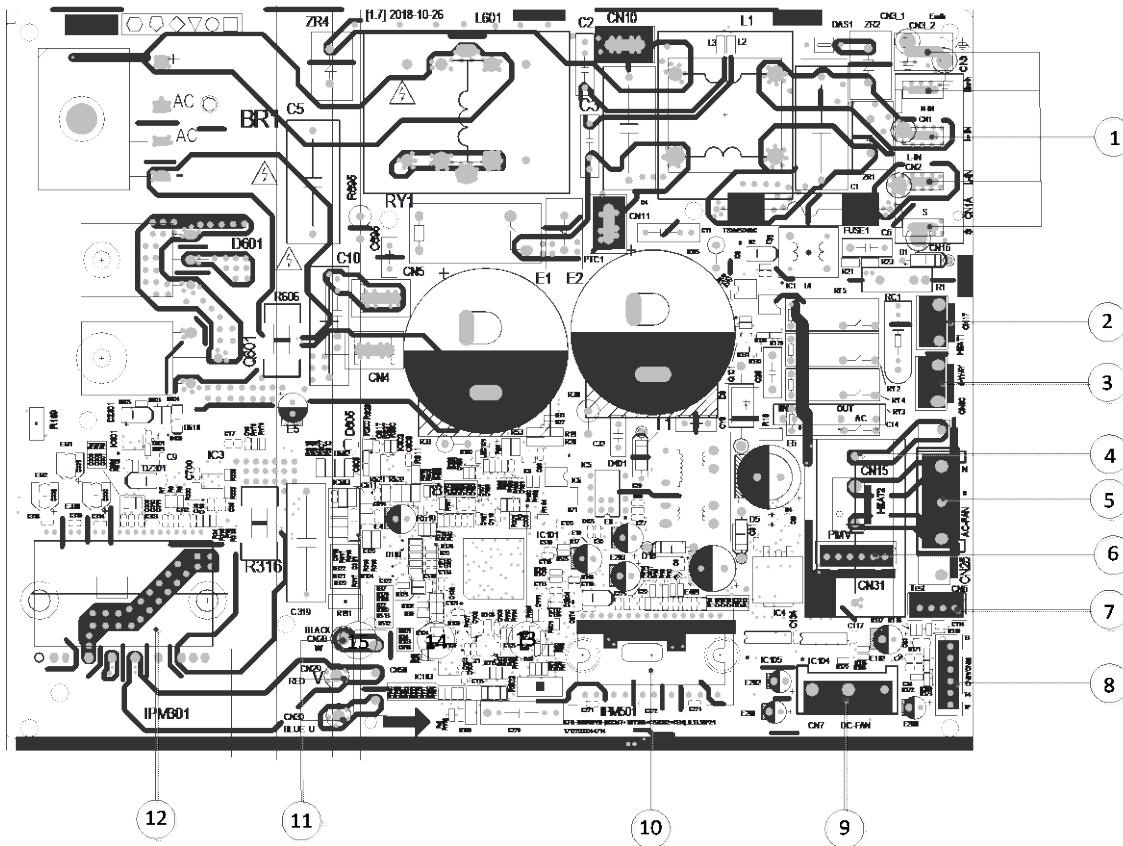

No.	Name	CN#	Meaning
1	Power Supply (CN1A)	CN3	Earth: connect to Ground
		CN1	N_in: connect to N-line (208-230V AC input)
		CN2	L_in: connect to L-line (208-230V AC input)
		CN16	S: connect to indoor unit communication
2	HEAT1	CN17	connect to compressor heater, 208-230V AC when is ON
3	4-WAY	CN60	connect to 4 way valve, 208-230V AC when is ON.
4	HEAT2	CN15	connect to chassis heater, 208-230V AC when is ON
5	AC-FAN	CN25	connect to AC fan
6	PMV	CN31	connect to Electric Expansion Valve
7	TESTPORT	CN6	used for testing
8	T5 T4 T3	CN21/CN22	connect to pipe temp. sensor T3, ambient temp. sensor T4, exhaust temp. sensor T5
9	DC-FAN	CN7	connect to DC fan
10	FAN_IPM	IPM 501	IPM for DC fan
11	W	CN28	connect to compressor
	U	CN29	0V AC (standby)
	V	CN30	10-200V AC (running)
12	COMP_IPM	IPM 301	IPM for compressor

PCB board of CHF18CD(O)

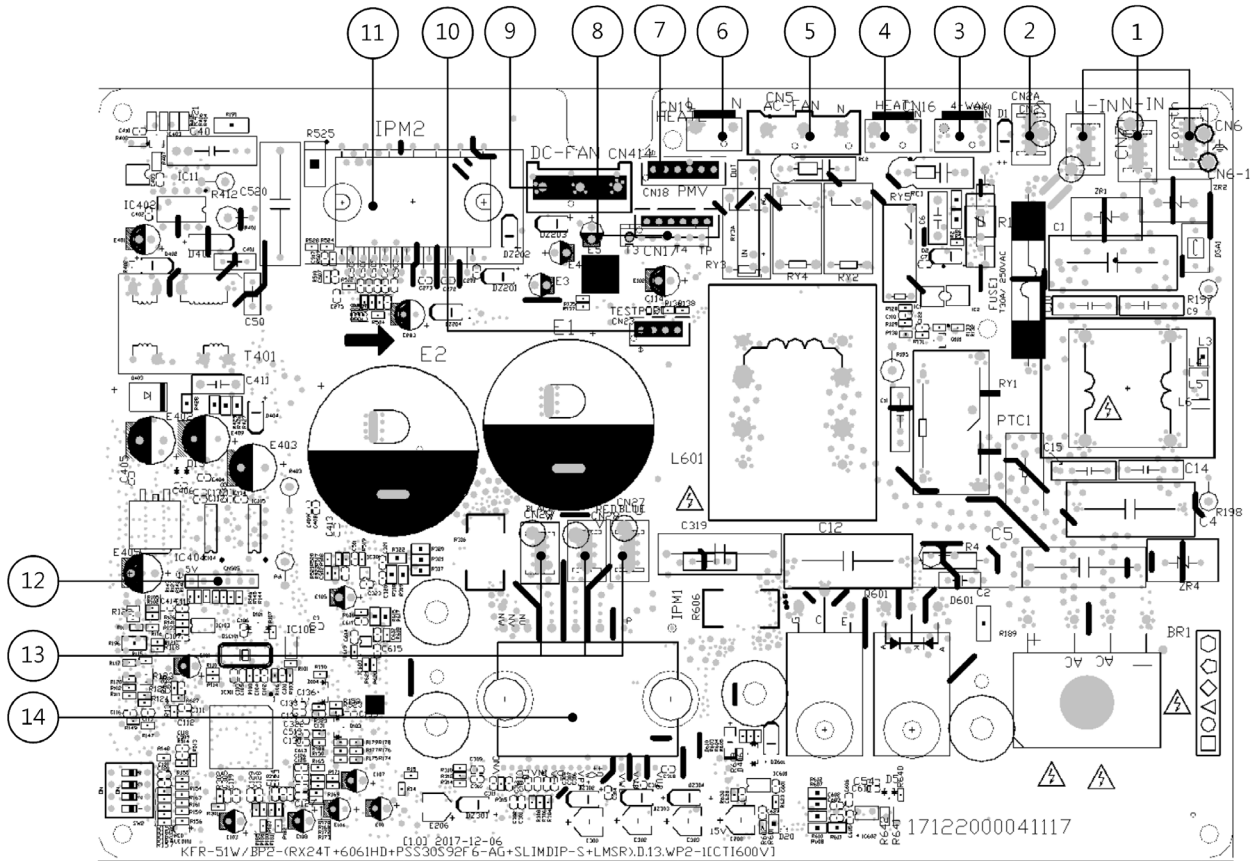

No.	Name	CN#	Meaning
1	Power Supply (CN3)	CN6	Earth: connect to Ground
		CN7	N_in: connect to N-line (208-230V AC input)
		CN8	L_in: connect to L-line (208-230V AC input)
2	S	CN2	S: connect to indoor unit communication
3	4-WAY	CN60	connect to 4 way valve, 208-230V AC when is ON.
4	HEAT1	CN16	connect to compressor heater, 208-230V AC when is ON
5	AC-FAN	CN5	connect to AC fan
6	HEAT2	CN19	connect to chassis heater, 208-230V AC when is ON
7	PMV	CN18	connect to Electric Expansion Valve
8	T5 T4 T3	CN17	connect to pipe temp. sensor T3, ambient temp. sensor T4, exhaust temp. sensor T5
9	DC-FAN	CN41	connect to DC fan
10	TESTPORT	CN23	used for testing
11	FAN_IPM	IPM2	IPM for DC fan
12	EE_PORT	CN505	EEPROM programmer port
		CN28	connect to compressor
		CN29	0V AC (standby)
13	U	CN28	connect to compressor
	V	CN29	0V AC (standby)
14	W	CN30	10-200V AC (running)
	COMP_IPM	IPM1	IPM for compressor

PCB board of CZP18CD(O), CZP24CD(O)

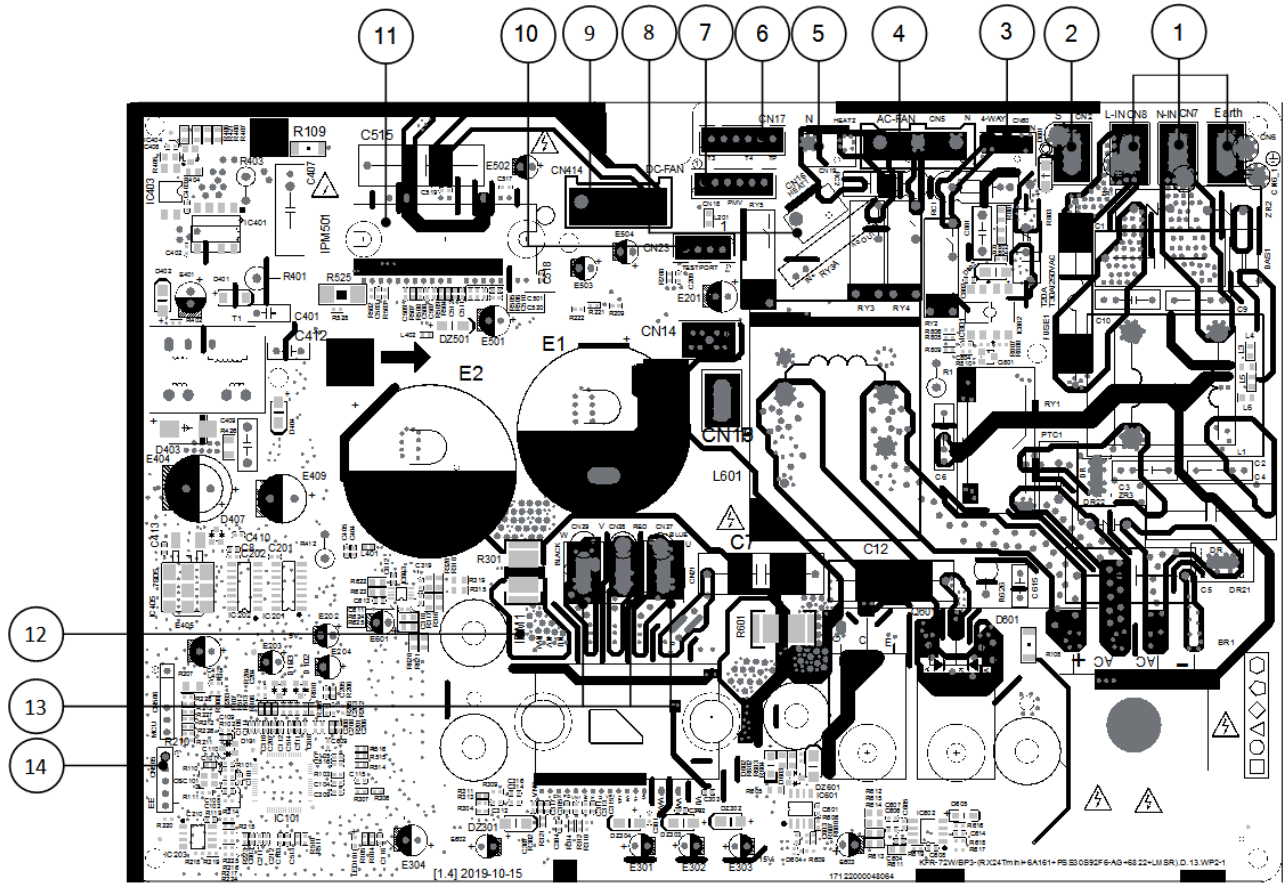

No.	Name	CN#	Meaning	
1	Power Supply	CN6	Earth: connect to Ground	
		CN7	N_in: connect to N-line (208-230V AC input)	
		CN8	L_in: connect to L-line (208-230V AC input)	
2	S	CN2	S: connect to indoor unit communication	
3	4-WAY	CN60	connect to 4 way valve, 208-230V AC when is ON.	
4	AC-FAN	CN5	connect to AC fan	
5	HEAT2	CN19	connect to chassis heater, 208-230V AC when is ON	
6	T5 T4 T3	CN17	connect to pipe temp. sensor T3, ambient temp. sensor T4, exhaust temp. sensor T5	
7	PMV	CN18	connect to Electric Expansion Valve	
8	HEAT1	CN16	connect to compressor heater, 208-230V AC when is ON	
9	DC-FAN	CN414	connect to DC fan	
10	TESTPORT	CN23	used for testing	
11	FAN_IPM	IPM501	IPM for DC fan	
13	COMP_IPM	IPM1	IPM for compressor	
		U	CN27	connect to compressor
		V	CN28	0V AC (standby)
	W	CN29	200-300V AC (running)	
14	EE_PORT	CN505	EEPROM programmer port	

PCB board of CHF24CD(O), CZP36CD(O)

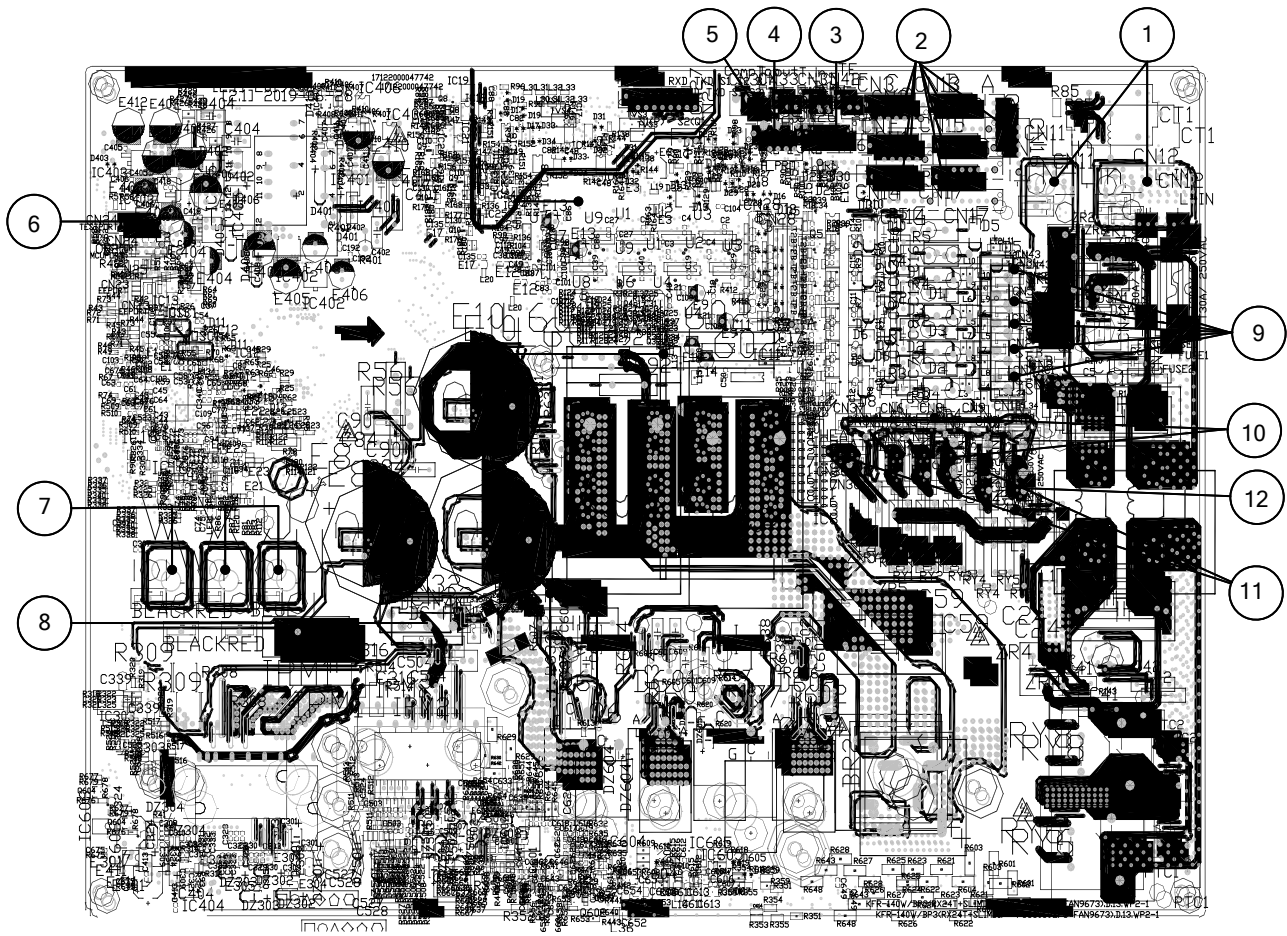

No.	Name	CN#	Meaning
1	Power Supply	CN11	N_in: connect to N-line (208-230V AC input)
		CN12	L_in: connect to L-line (208-230V AC input)
2	EEV-A	CN16	connect to electric expansion valve
	EEV-B	CN13	
	EEV-C	CN3	
	EEV-D	CN15	
	EEV-E	CN1	
	EEV-F	CN17	
3	T5 T4 T3	CN26	connect to pipe temp. sensor T3, ambient temp. sensor T4, exhaust temp. sensor T5
4	H-PRO,L-RPO	CN29	connect to high and low pressure switch(pin1-pin2&pin3-pin4:5VDC pulse wave)
5	OLP TEMP. SENSOR	CN30	connect to compressor top temp. sensor (5VDC Pulse wave)
6	TESTPORT	CN24	used for testing
7	COMPRESSOR	U	connect to compressor
		V	0V AC (standby)
		W	10-200V AC (running)

8	DC-FAN	CN32	connect to DC fan
9	S-E	CN31	S: connect to indoor unit communication(pin1-pin2: 24VDC Pulse wave; pin2-pin3: 208-230V AC input)
	S-D	CN5	
	S-C(mono)	CN34	
	S-B	CN2	
	S-A	CN4	
10	HEAT_D	CN8	connect to chassis heater, 208-230V AC when is ON
		CN20	
11	HEAT_Y	CN21	connect to compressor heater, 208-230V AC when is ON
		CN36	
12	4-WAY	CN38	connect to 4 way valve, 208-230V AC when is ON.

PCB board of CHF36CD(O), CZP48CD(O), CHF48CD(O), CZP60CD(O)

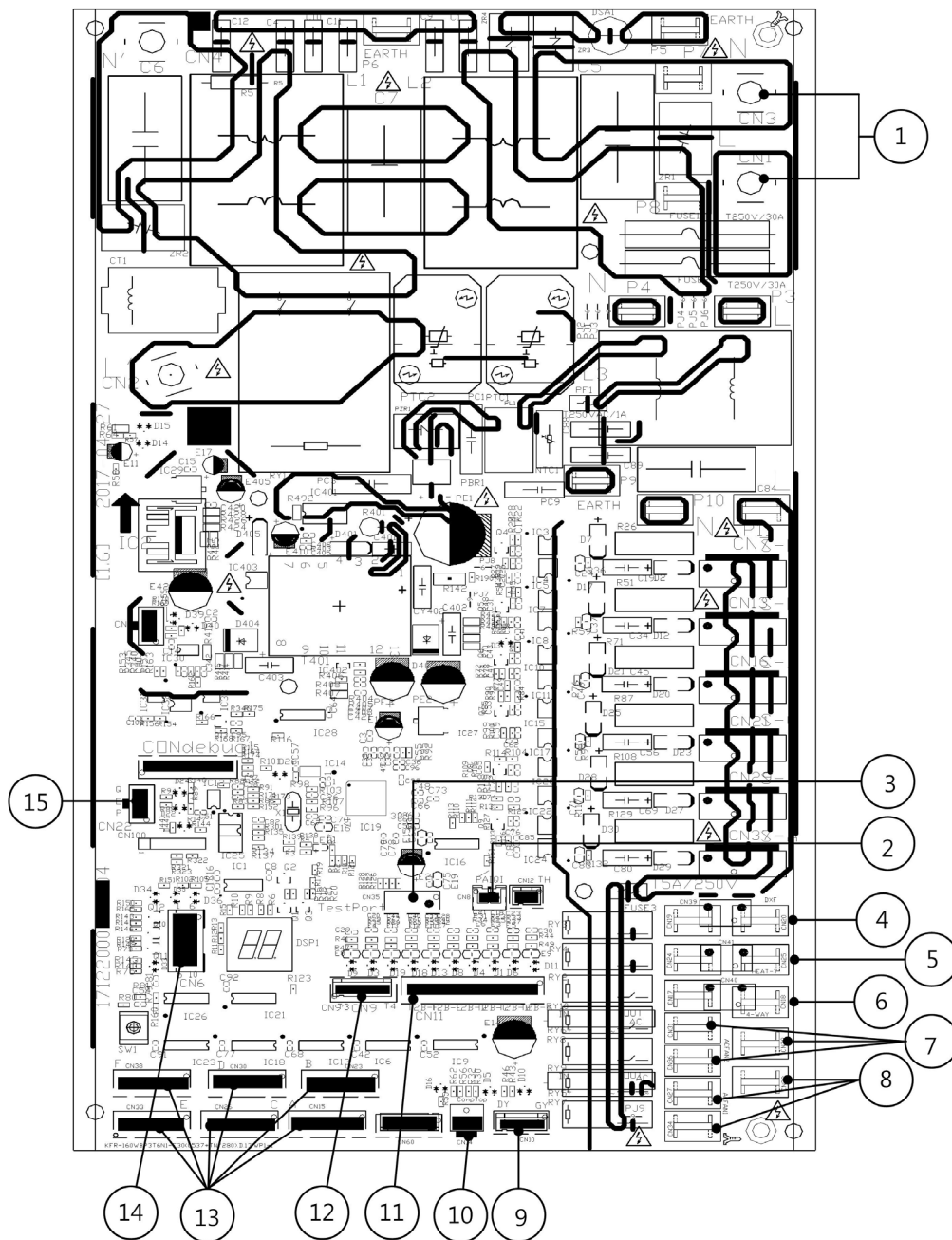

No.	Name	CN#	Meaning
1	Power Supply	CN1	L1_in: connect to L1-line (230V AC input)
		CN3	L2_in: connect to L2-line (230V AC input)
2	T5	CN8	Exhaust temp. sensor T5
3	TESTPORT	CN35	used for testing
4	HEAT1	CN19/CN20	connect to chassis heater, 208-230V AC when is ON
5	HEAT2	CN24/CN25	connect to compressor heater, 208-230V AC when is ON
6	4-WAY	CN17/CN18	connect to 4 way valve, 208-230V AC when is ON.
7	AC-FAN2	CN31/CN36/CN28	connect to AC fan2
8	AC-FAN1	CN27/CN34/CN32	connect to AC fan1
9	H-PRO,L-RPO	CN10	connect to high and low pressure switch

			(pin1-pin2&pin3-pin4:5VDC pulse wave)
10	Compressor Top	CN14	connect to compressor top temperature sensor
11	T2B	CN11	connect to pipe temp. sensor T2B
12	T4 T3	CN9	connect to pipe temp. sensor T3, ambient temp. sensor T4
13	PMV	CN15/CN23/CN26/ CN30/CN33/CN38	connect to Electric Expansion Valve(A~F)
14	/	CN6	connect to IPM&PFC board CN9
15	PQE	CN22	Communication to indoor unit

**IPM board of CHF36CD(O),
CZP48CD(O),CHF48CD(O), CZP60CD(O)**

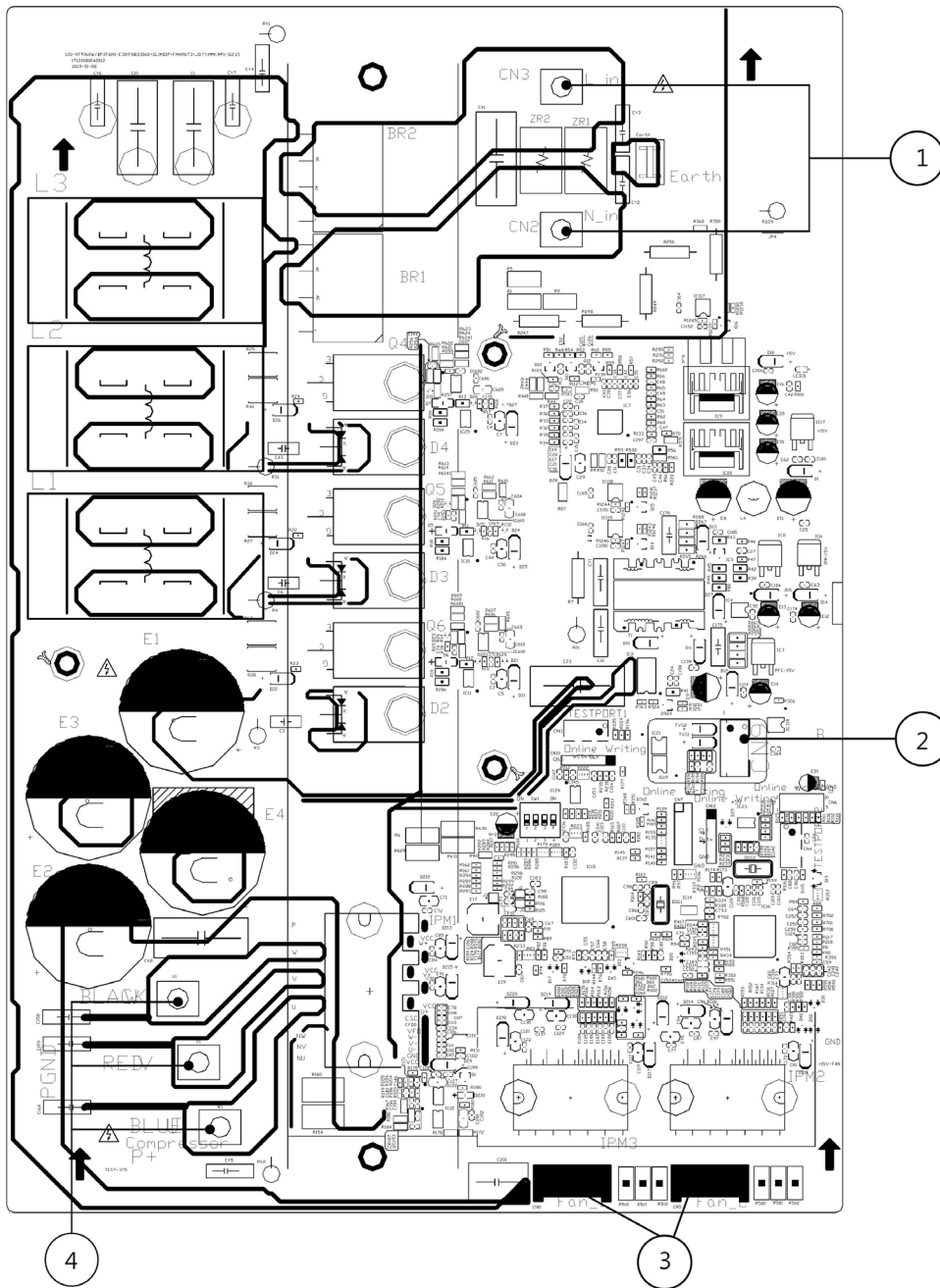

No.	Name	CN#	Meaning
1	Power Supply	CN3	connect to main board L-Out
		CN2	connect to main board N-Out
2	CN9	CN9	Connect to main PCB CN6
3	FAN_DC	FAN_1/FAN_2	connect to outdoor DC fan 1& DC fan 2
4	CN_COMP	U1	Connect to compressor
		V1	
		W1	

7. Fan Curves

CPA-09B,

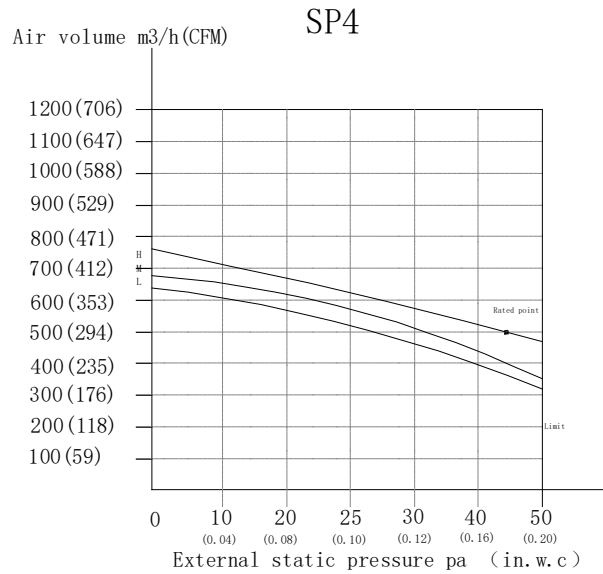
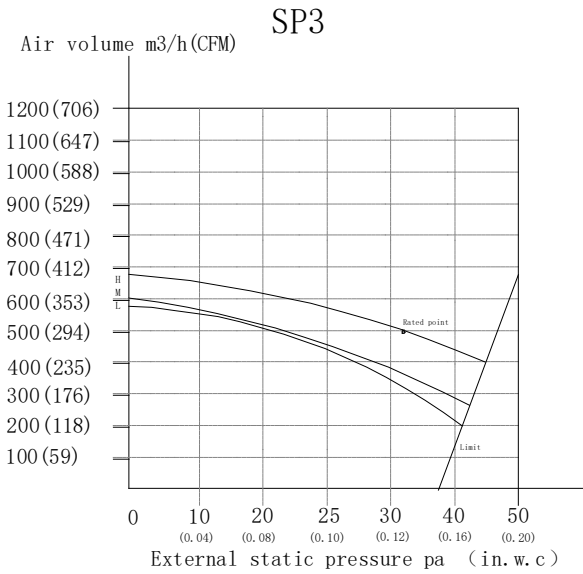
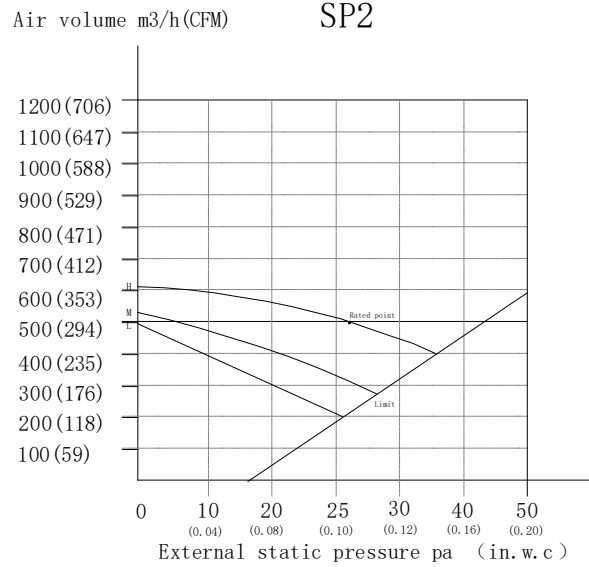
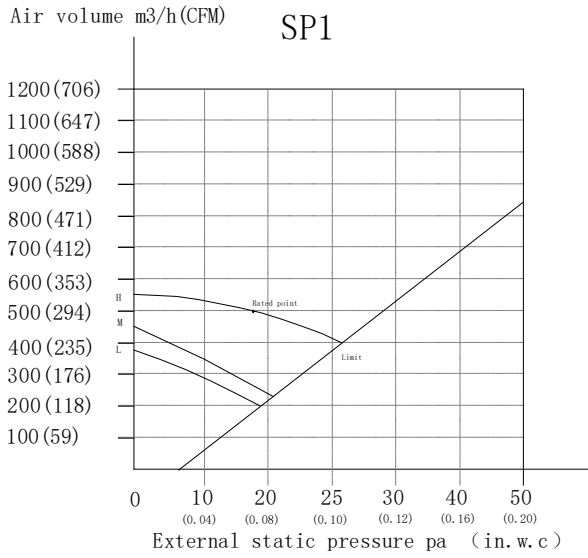

CPA-12B

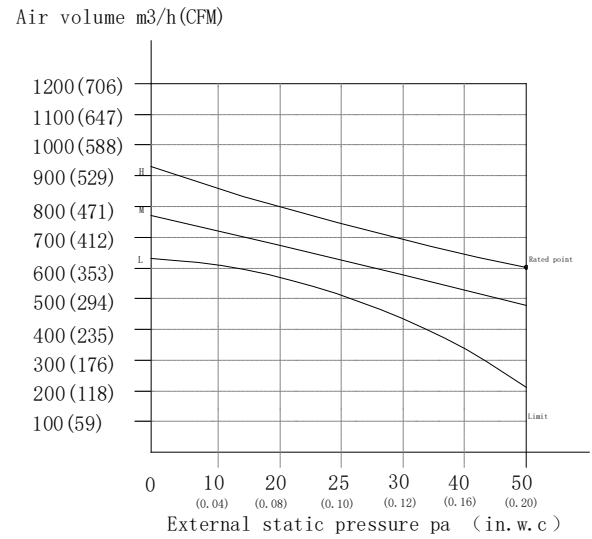
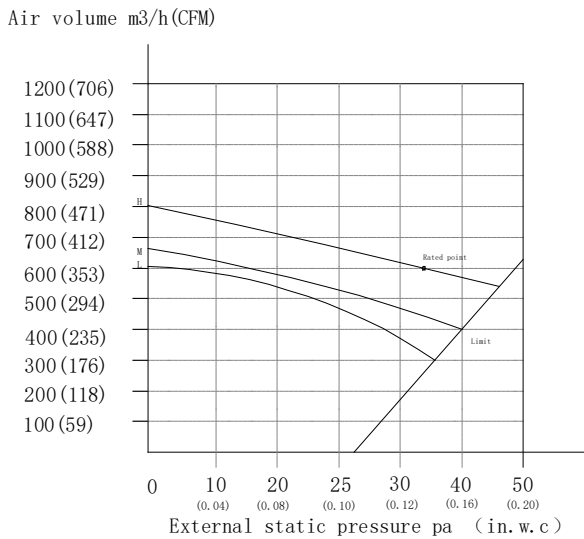
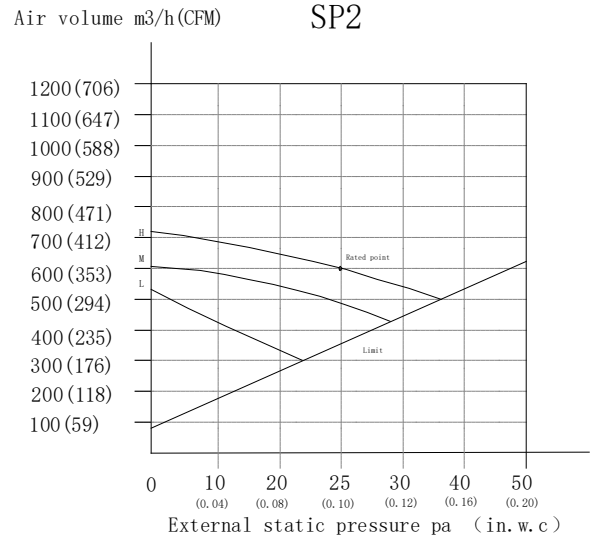
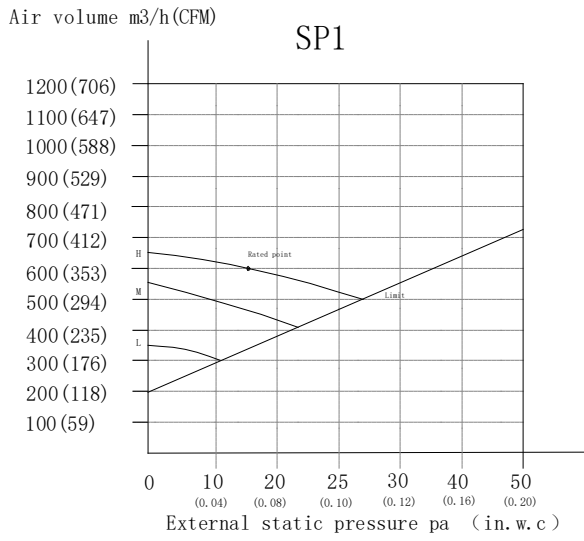

CPA-18B

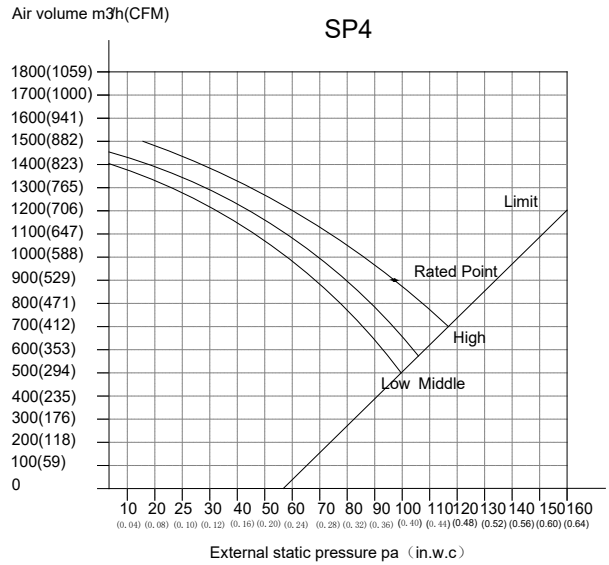
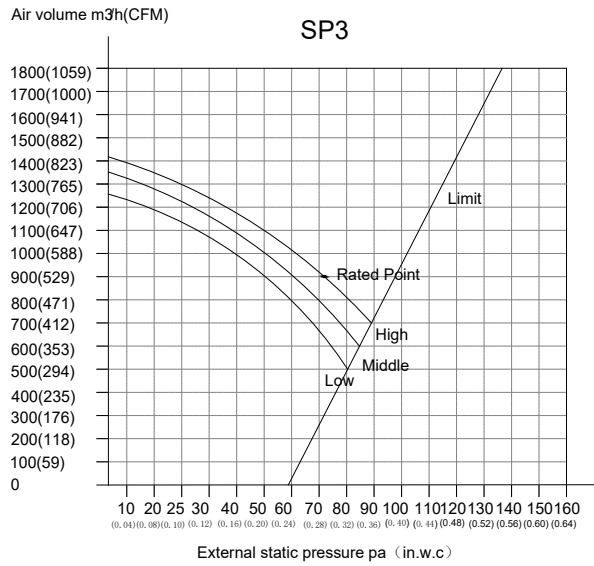
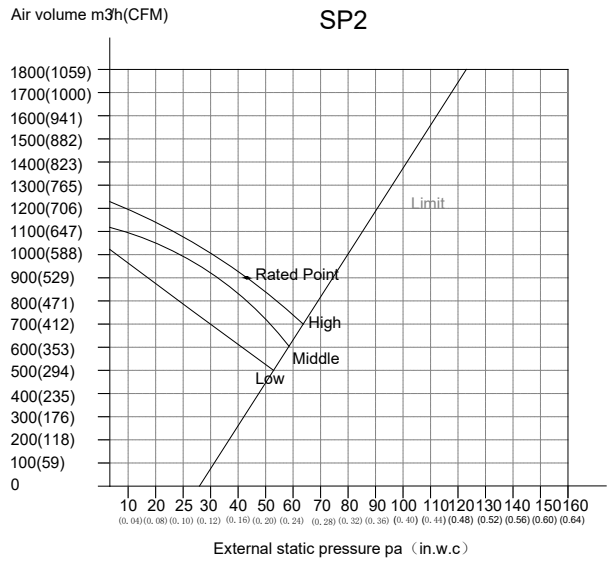
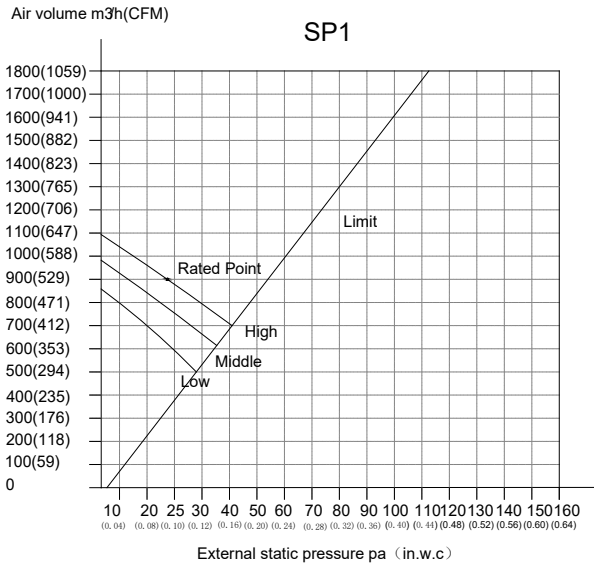

CPA-24B

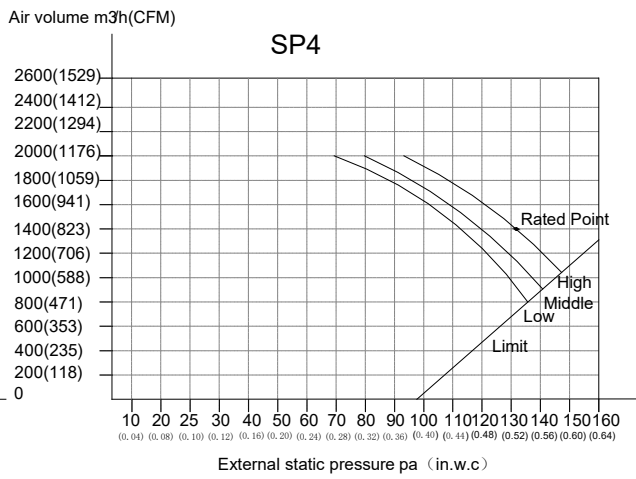
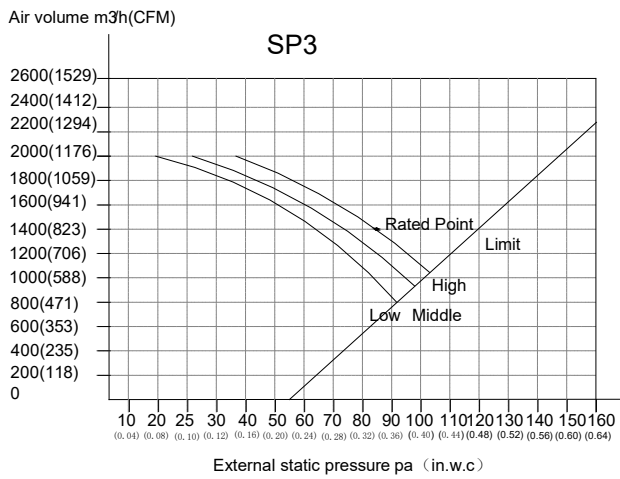
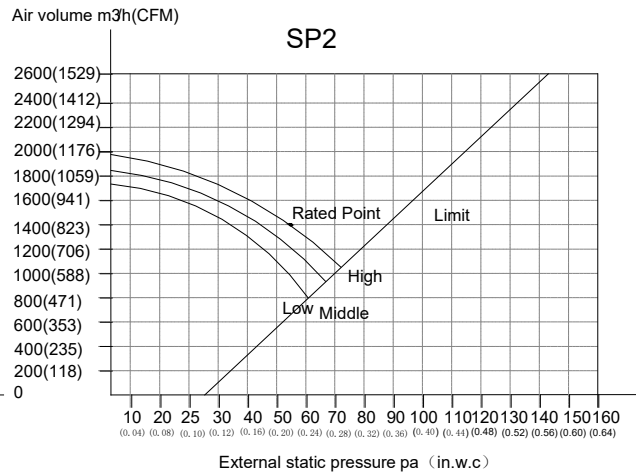
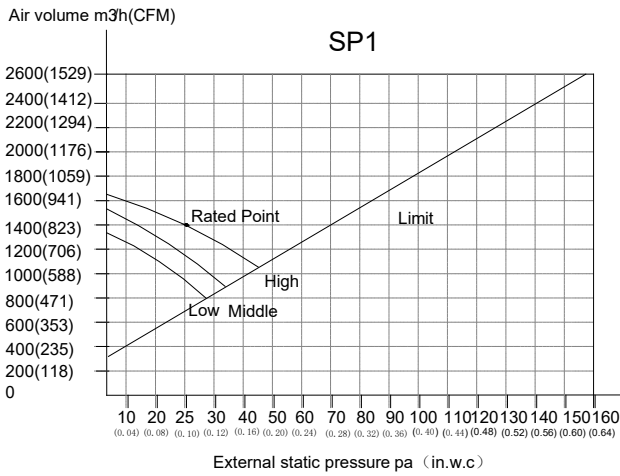

CPA-36DUB

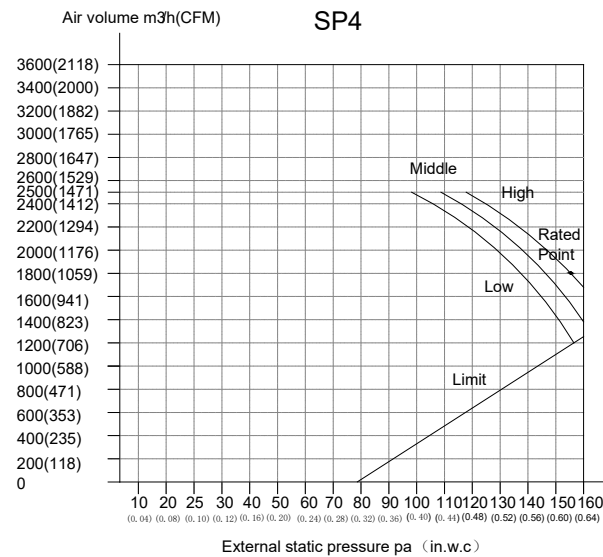
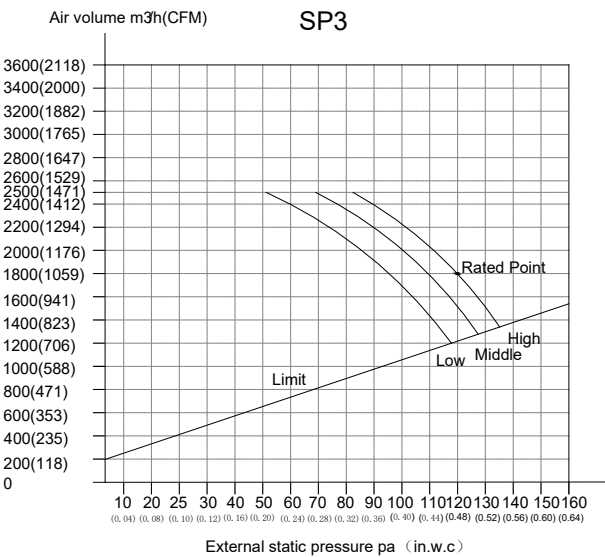
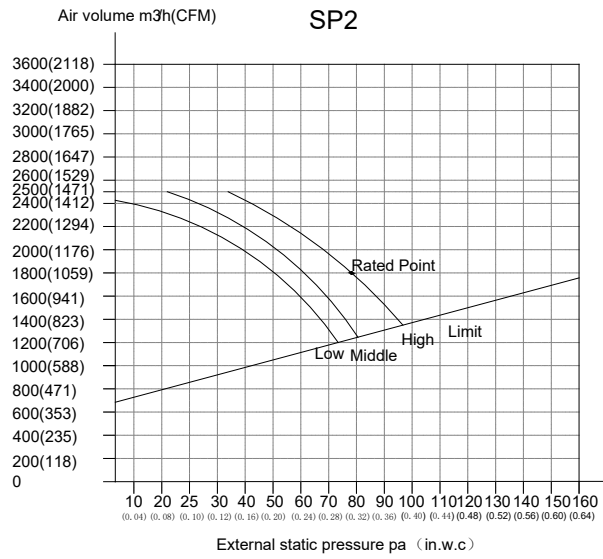
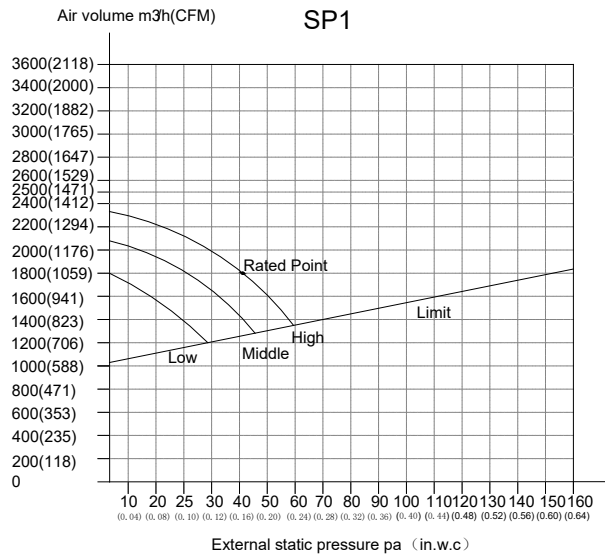

CPA-48DUB

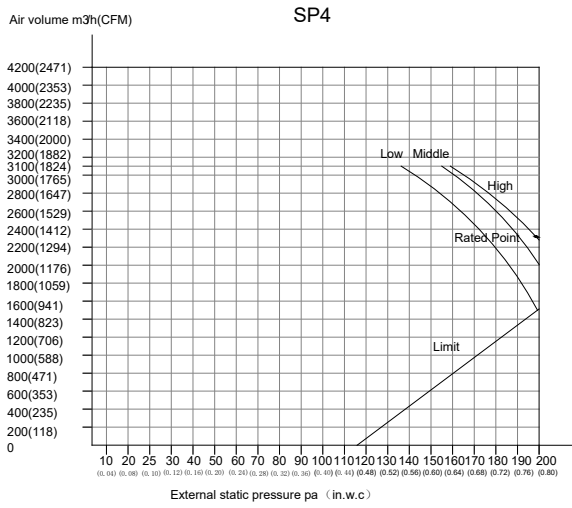
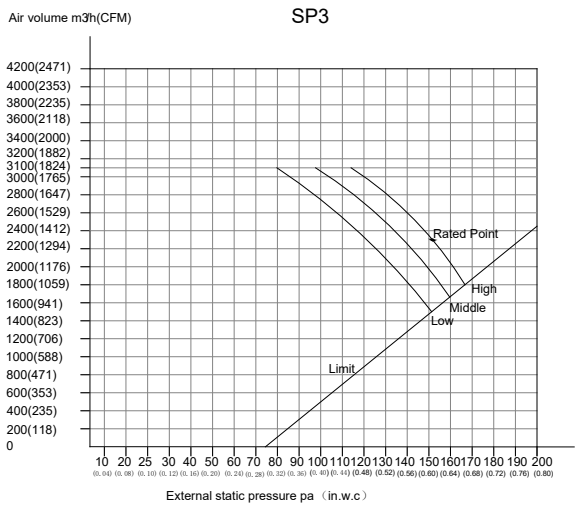
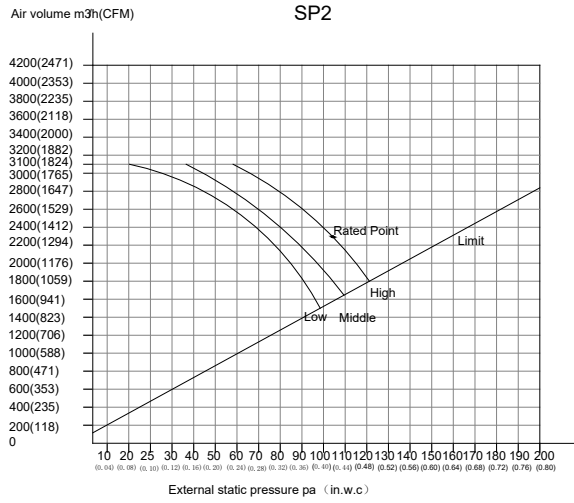
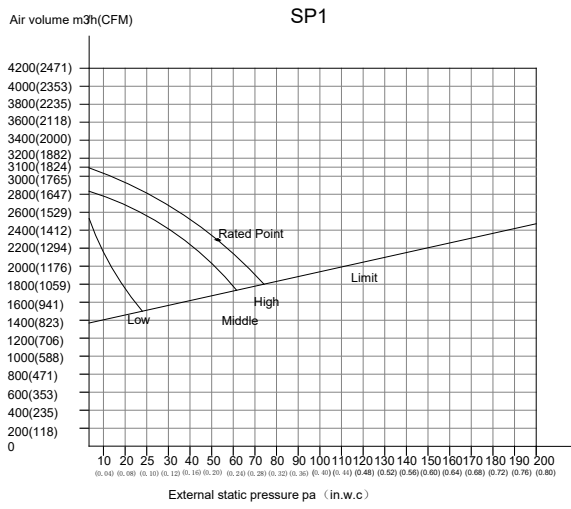

CPA-60DU

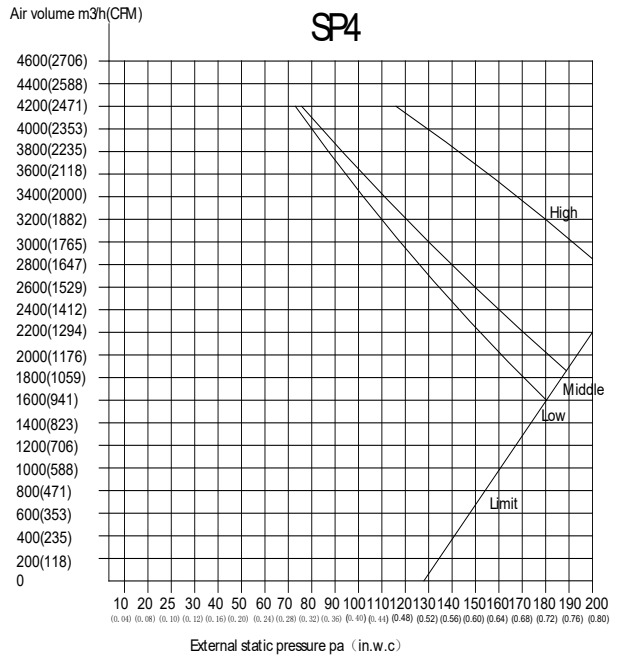
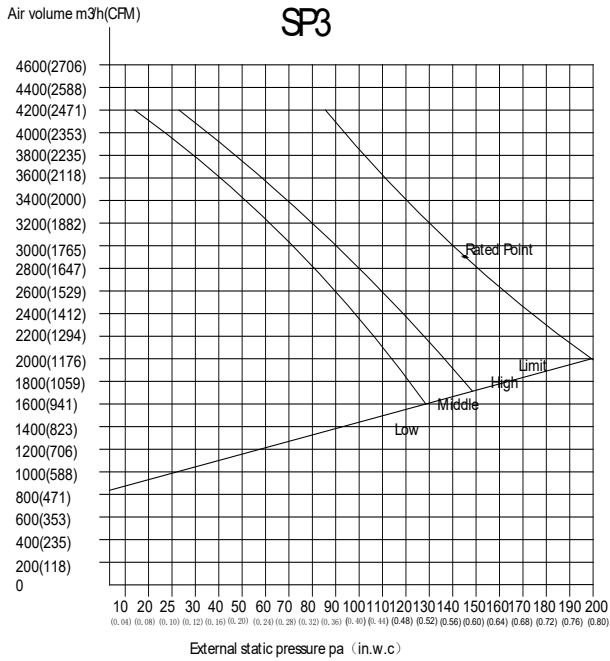
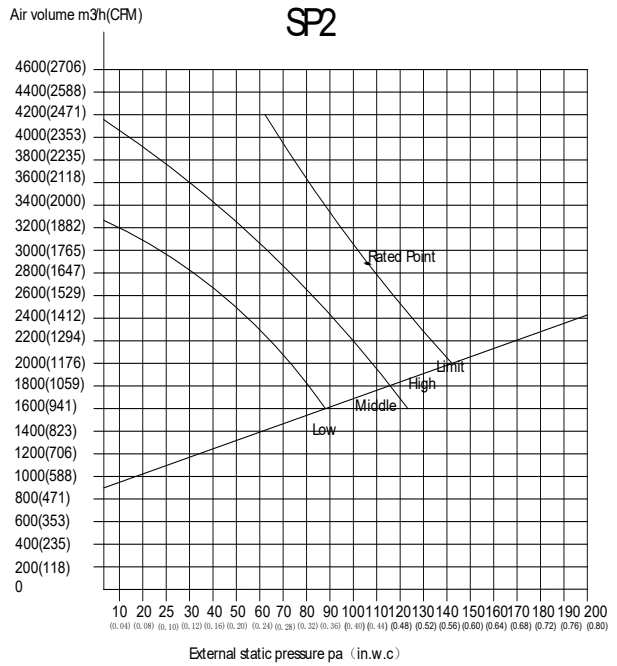
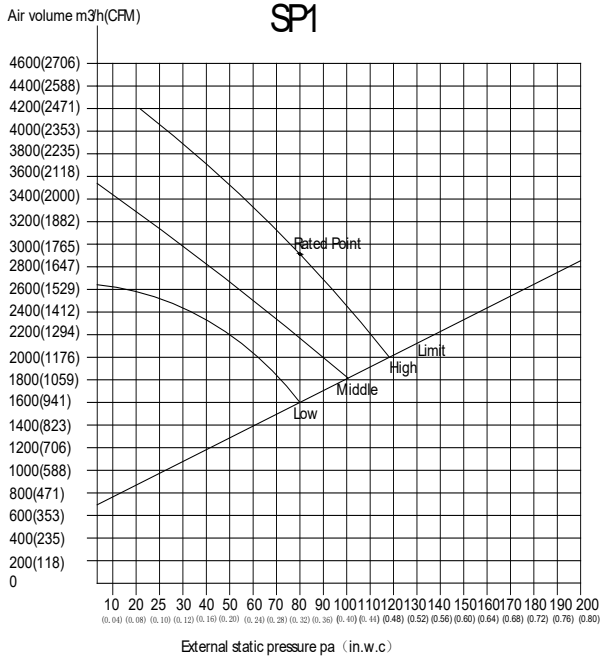

7.1 Using the wire controller to set external static pressure

- You can use the unit's automatic airflow adjustment function to set external static pressure.
- Automatic airflow adjustment is the volume of blow-off air that has been automatically adjusted to the quantity rated.

1. Make sure the test run is done with a dry coil. If the coil is not dry, run the unit for 2 hours in FAN ONLY mode to dry the coil.

2. Check that both power supply wiring and duct installation have been completed. Check that any closing dampers are open. Check that the air filter is properly attached to the air suction side passage of the unit.

3. If there is more than one air inlet and outlet, adjust the dampers so that the airflow rate of each air inlet and outlet conforms with the designed airflow rate. Make sure the unit is in FAN ONLY mode. Press and set the airflow adjustment button on the remote control to change the airflow rate from H or L.

4. Set the parameters for automatic airflow adjustment. When the air conditioning unit is off, perform the following steps:

- When the unit is turned off, hold the MODE button and

FAN button down together for three seconds. ("AF" indicator flashes for 3 times.)

- Press "△" or "▽" to select the AF.

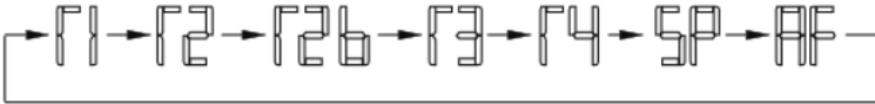

- Press "MODE". The air conditioning unit will then start the fan for airflow automatic adjustment.

After 3 to 6 minutes, the air conditioning unit stops operating once automatic airflow adjustment has finished.

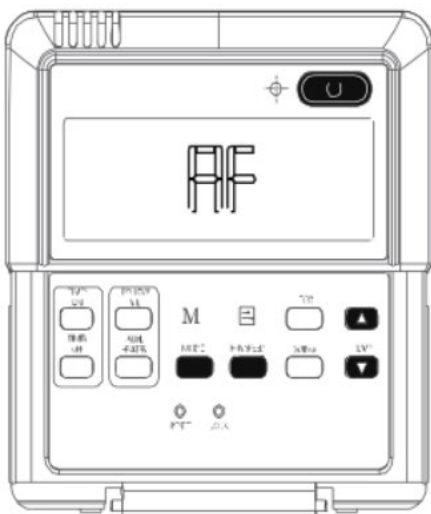

Caution: DO NOT adjust the dampers when automatic airflow adjustment is active.

7.2 Using the wire controller to set airflow rate

When the air conditioning unit is off, perform the following steps:

1. Press "MODE" and "FAN" for three seconds.
2. Press "△" or "▽" to select the SP.
3. Press "MODE" to set the airflow rate in the range of 0~4.



"0": No airflow change

"1"~"4": Airflow increase progressively

4. Press "ON/OFF" to finish the airflow setting.

8. Air Velocity Distributions

Console Units

Cooling

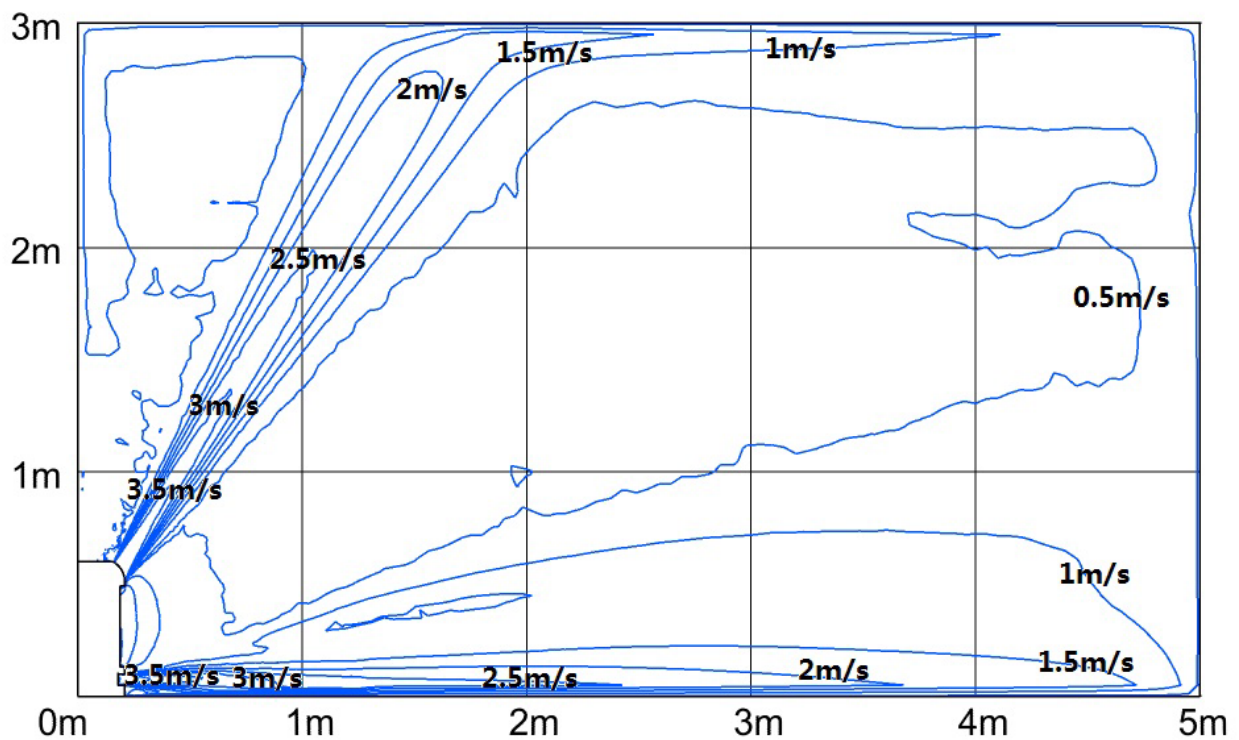
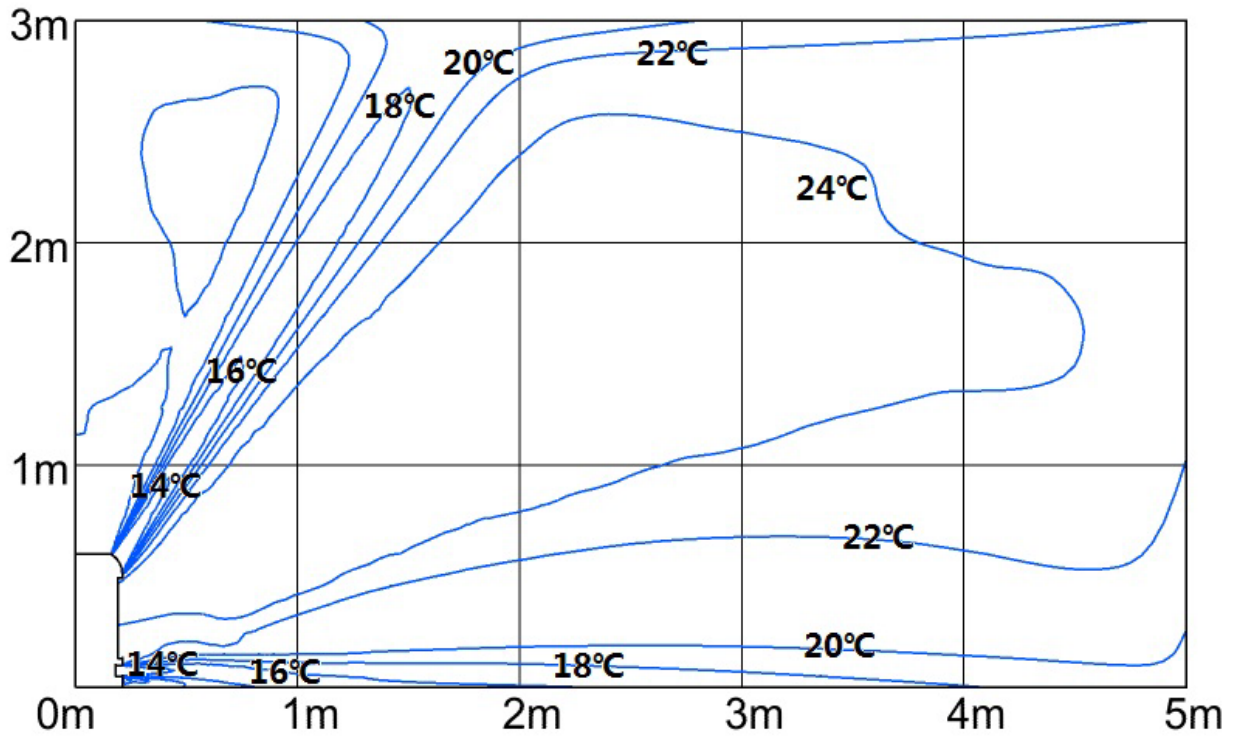

Heating

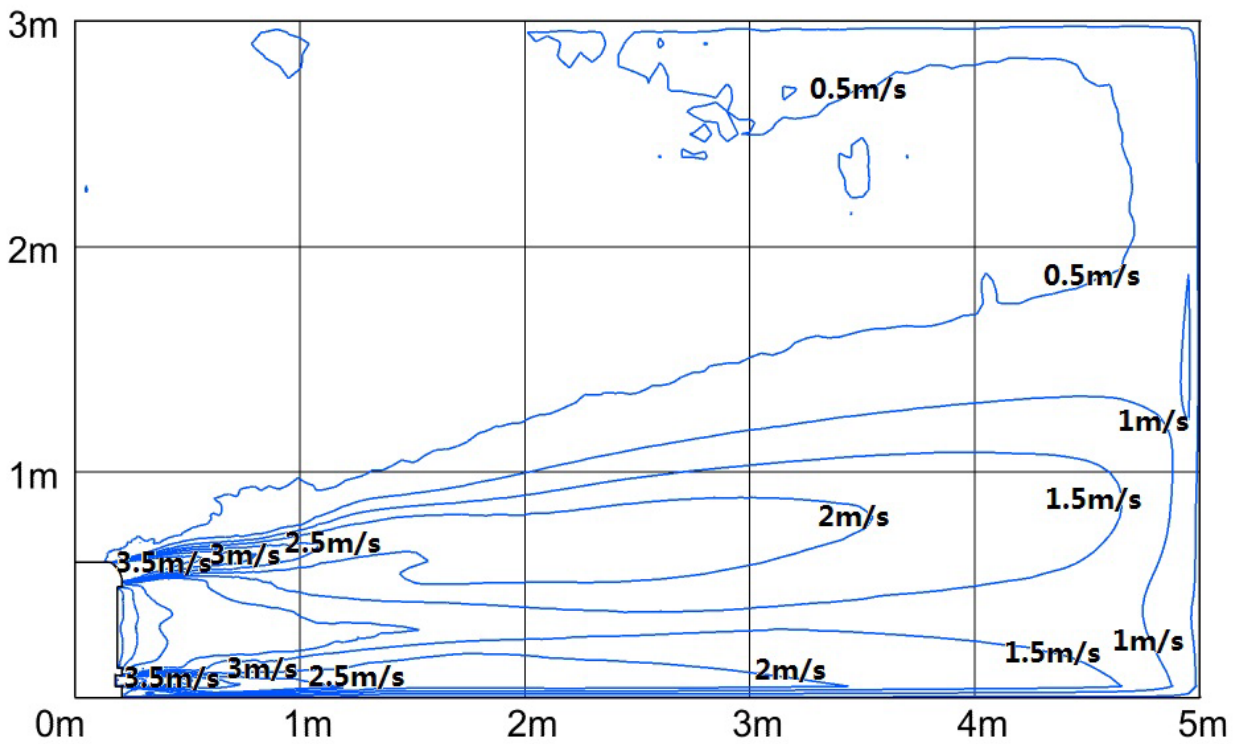
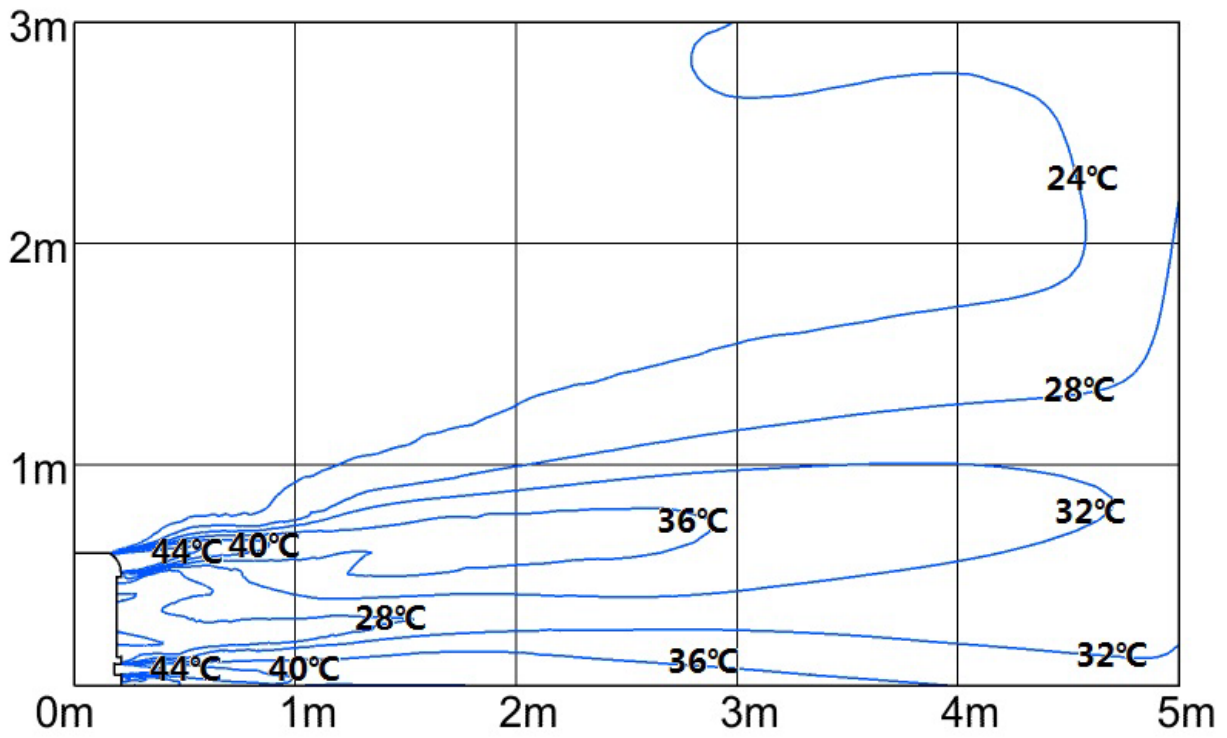

Cassette Units
9K/12K
Cooling
Discharge Angle 30°

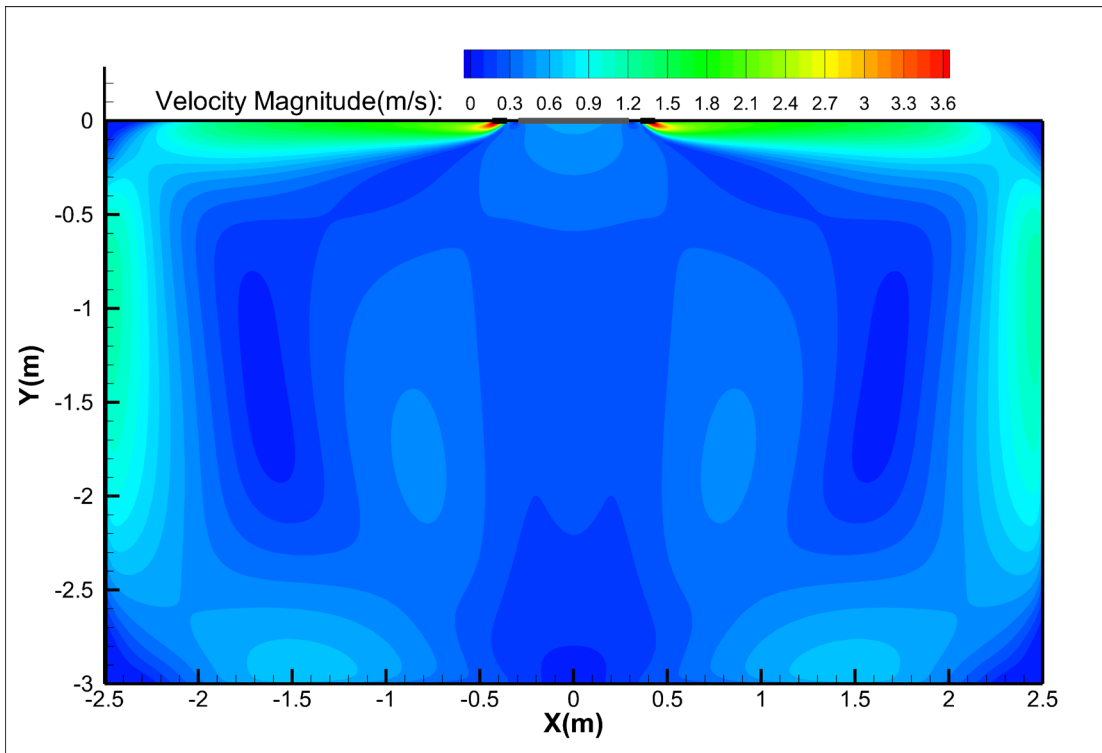
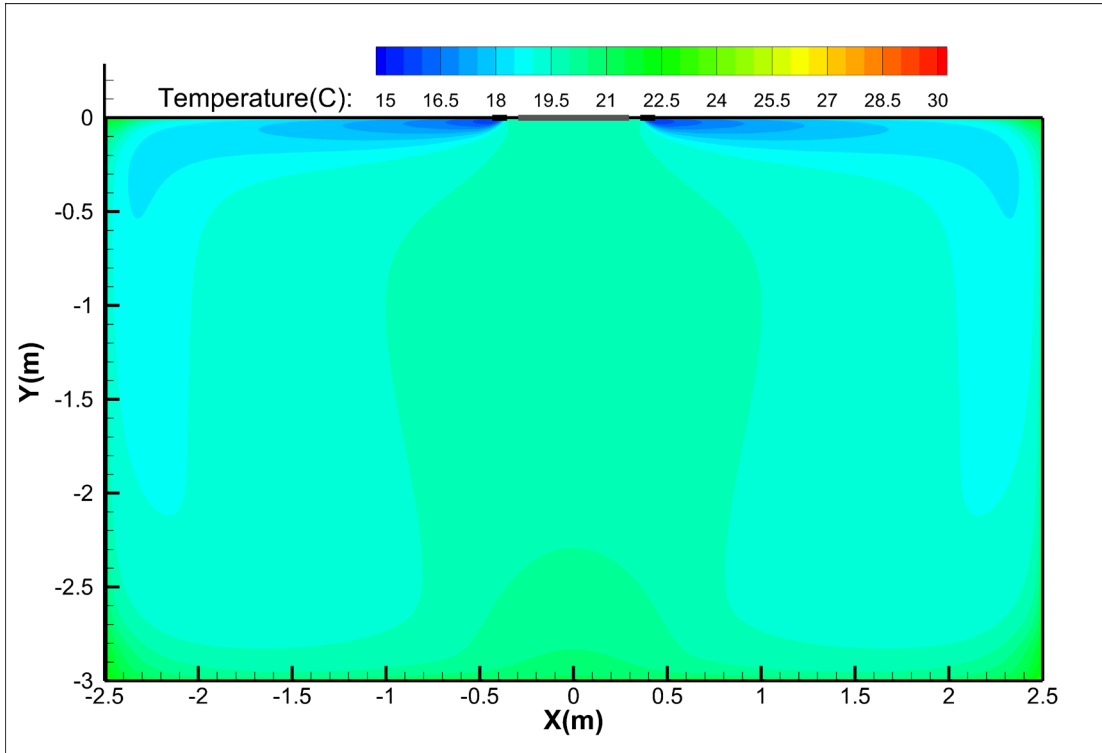

Discharge Angle 60°

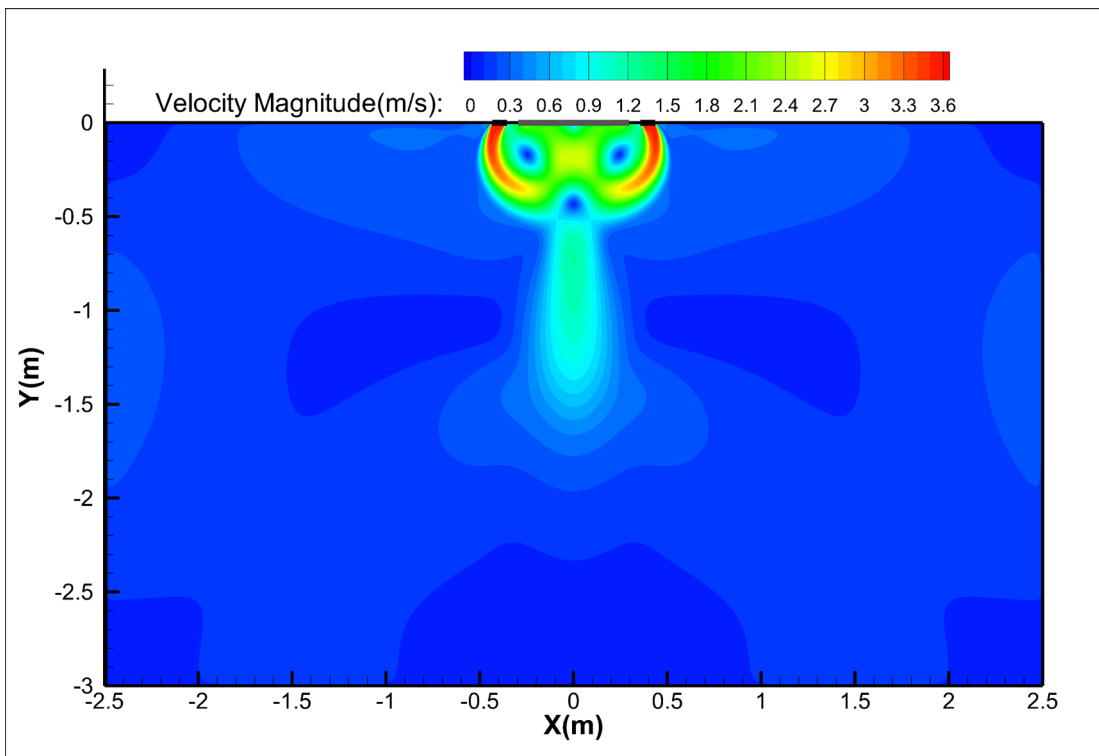
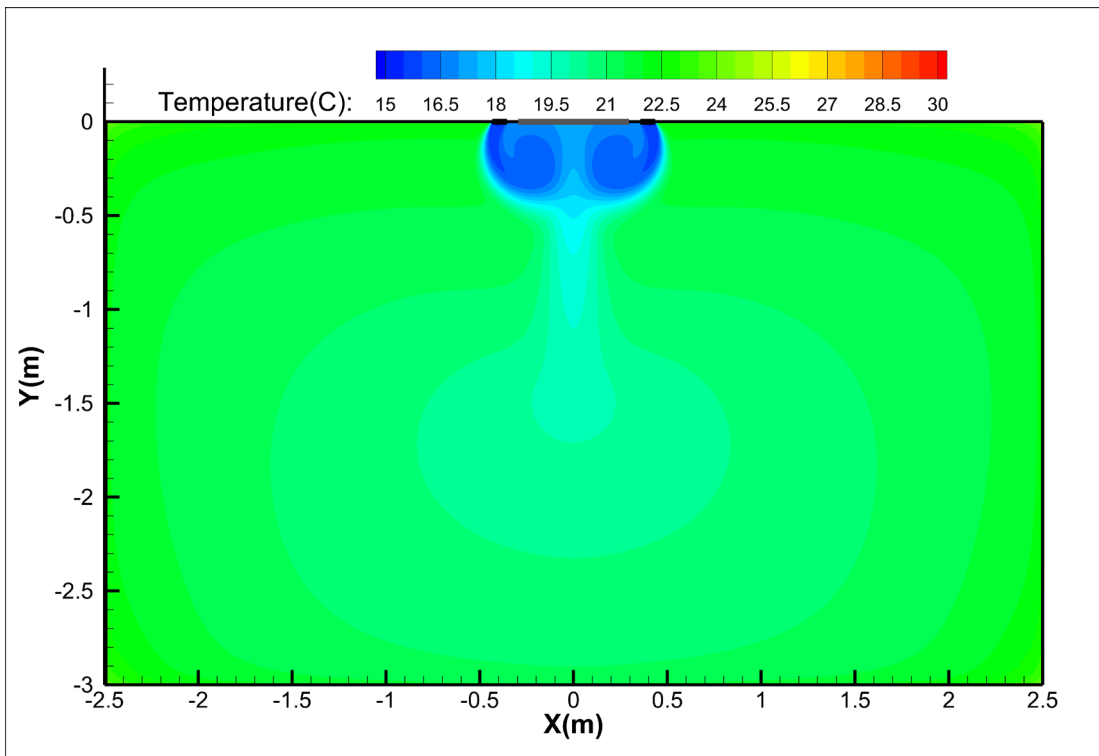

Heating
Discharge Angle 30°

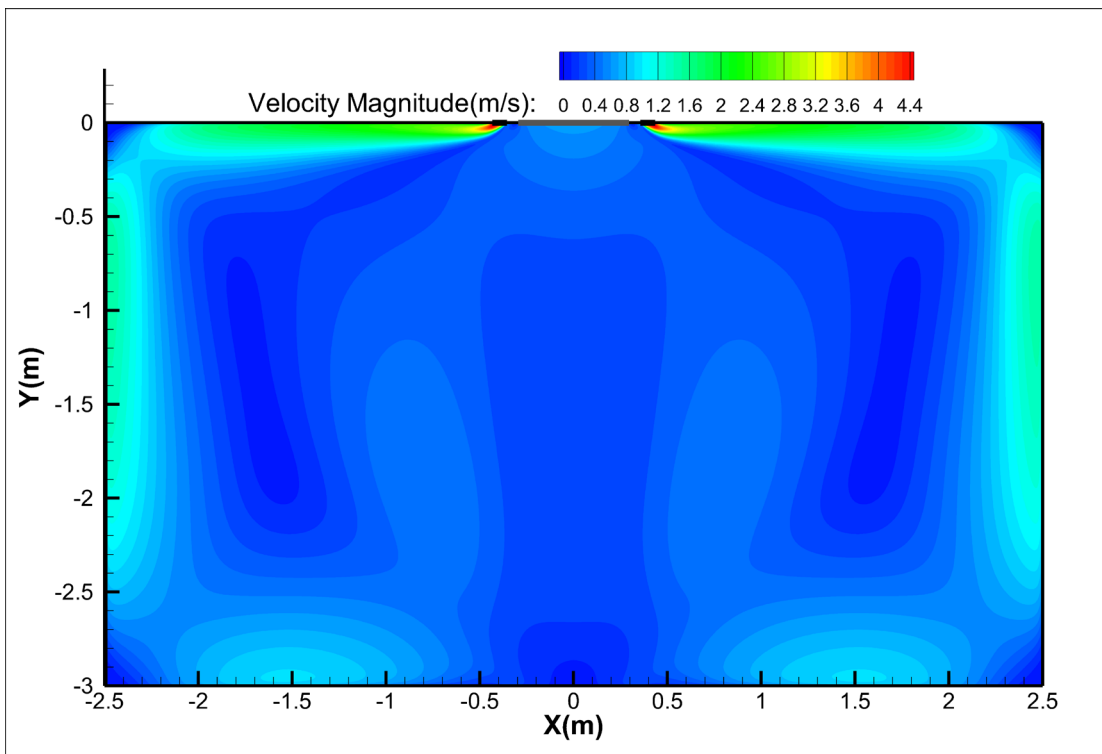
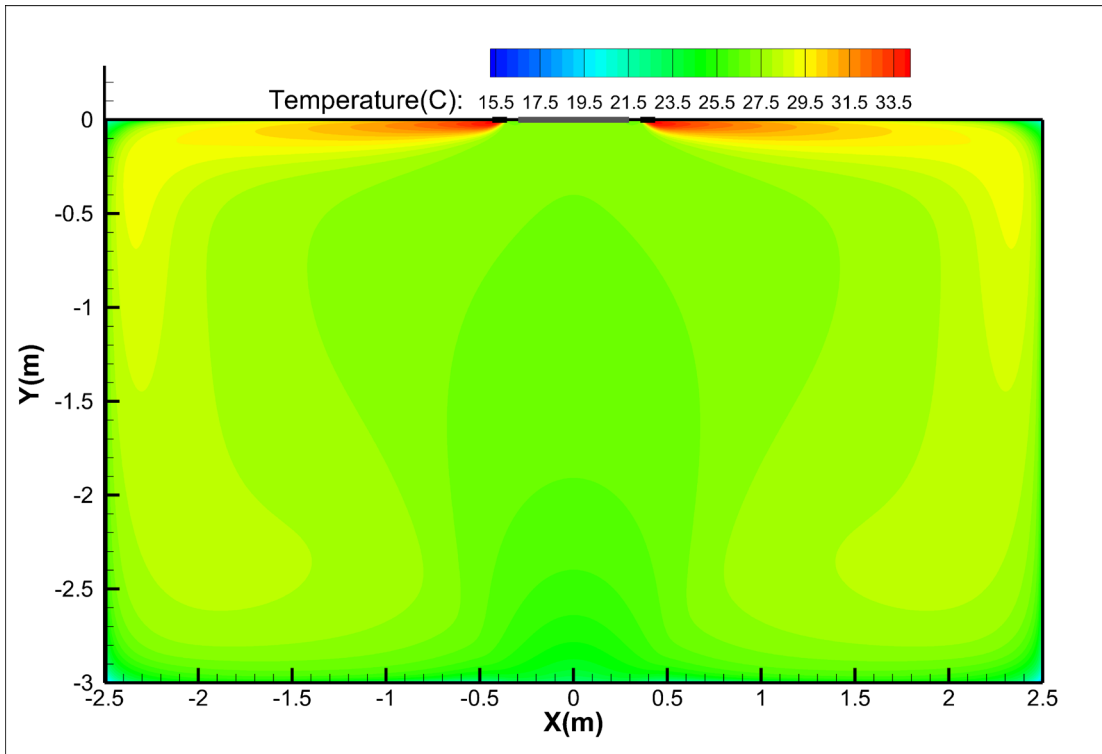

Discharge Angle 60°

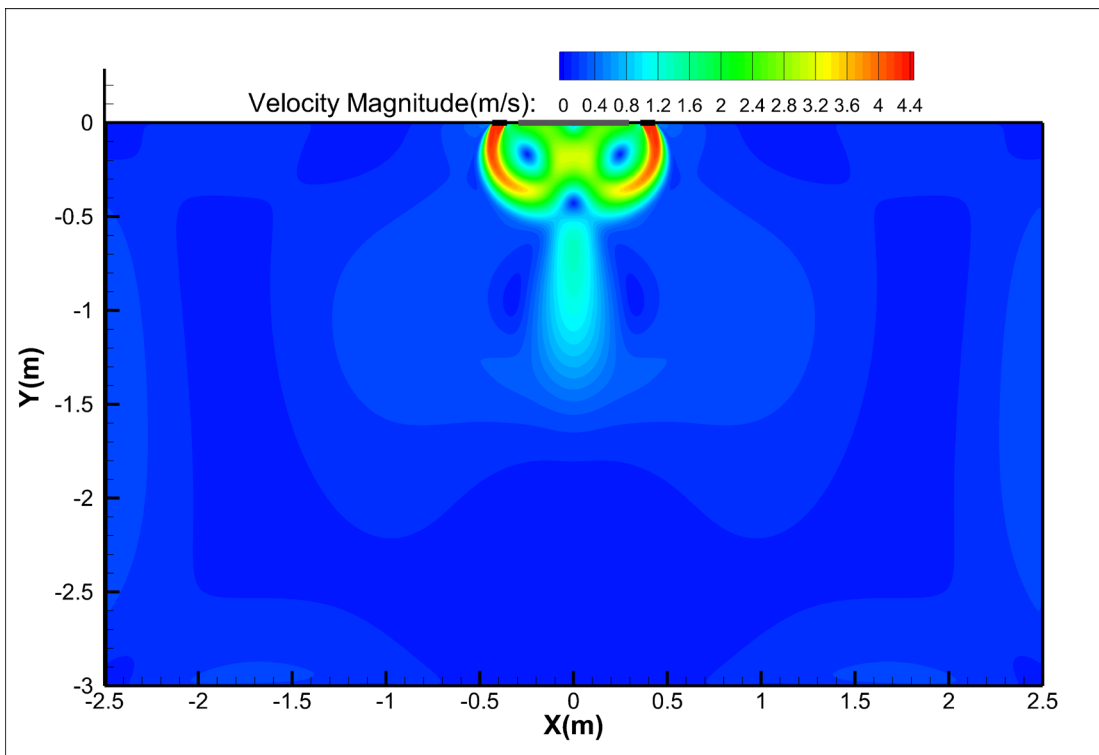
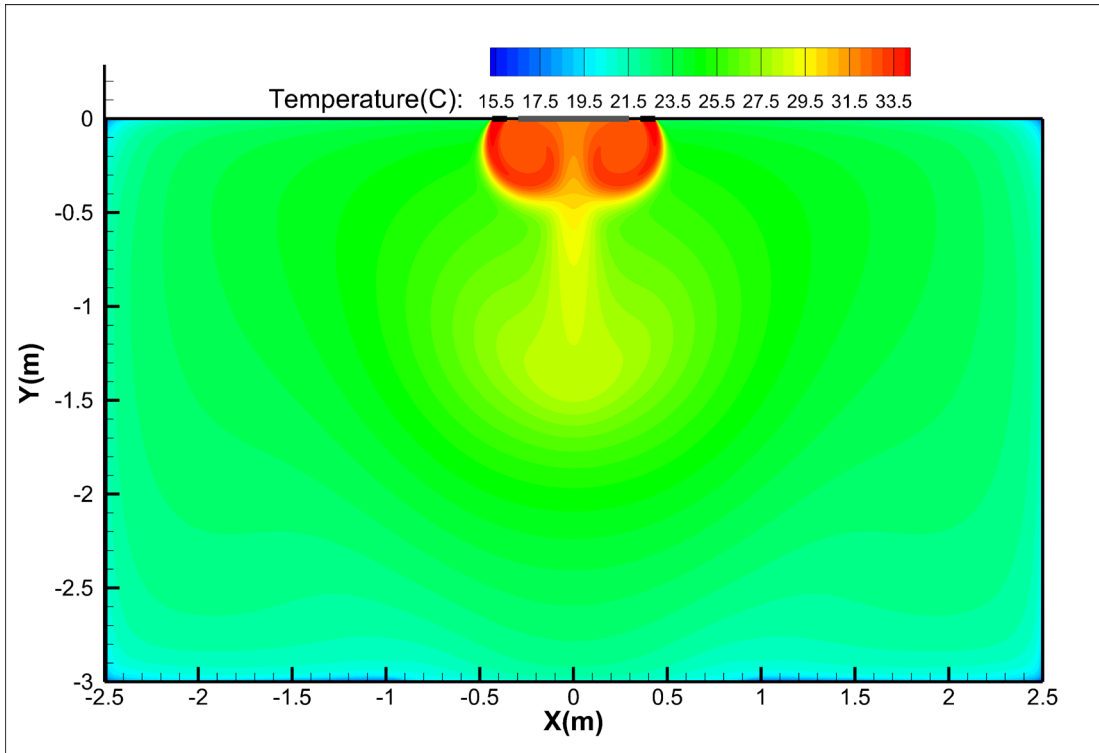

18K

Cooling

Discharge Angle 30°

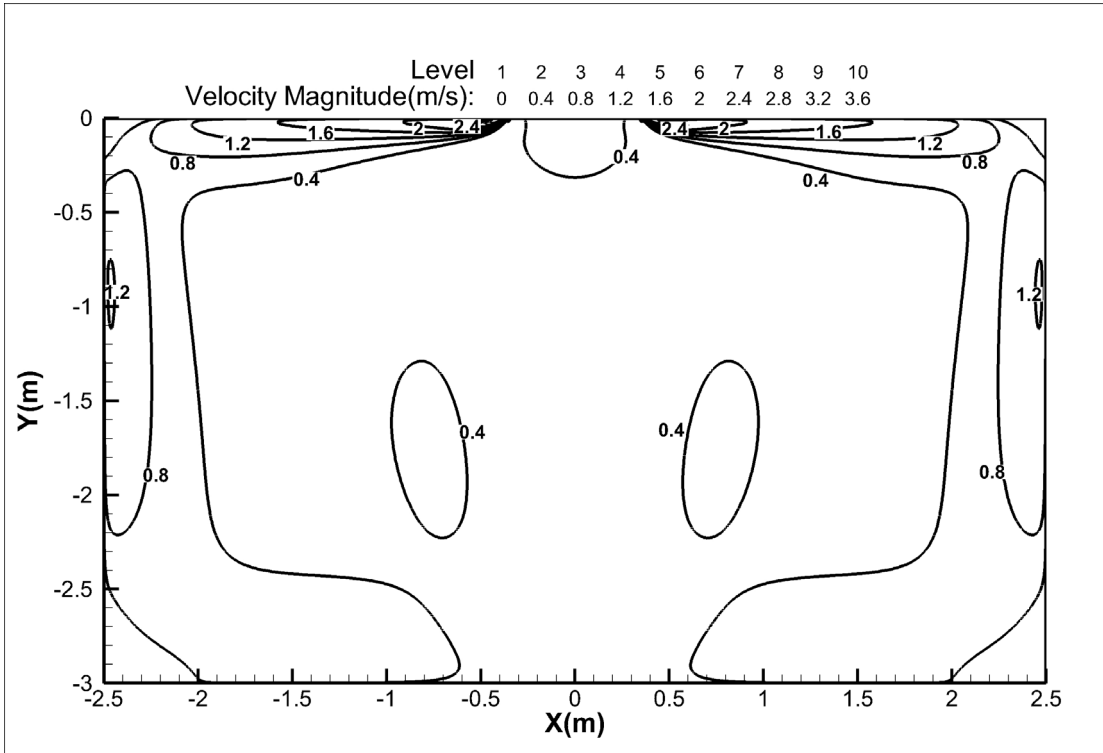
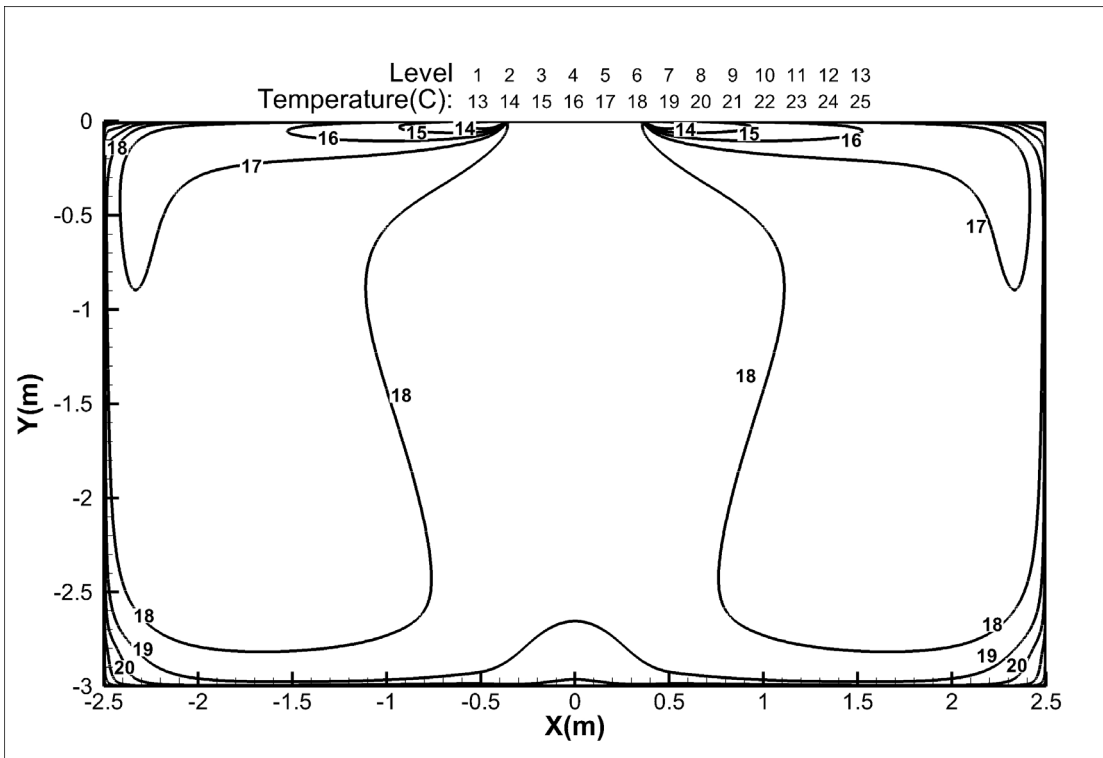

Discharge Angle 60°

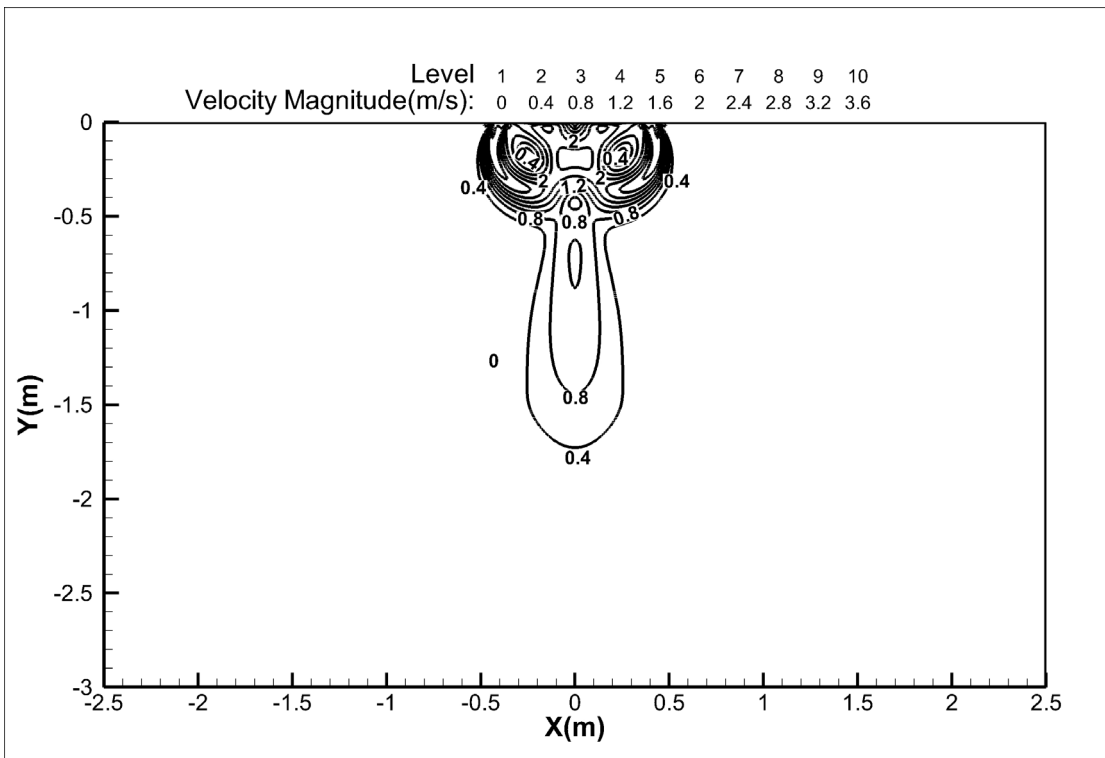
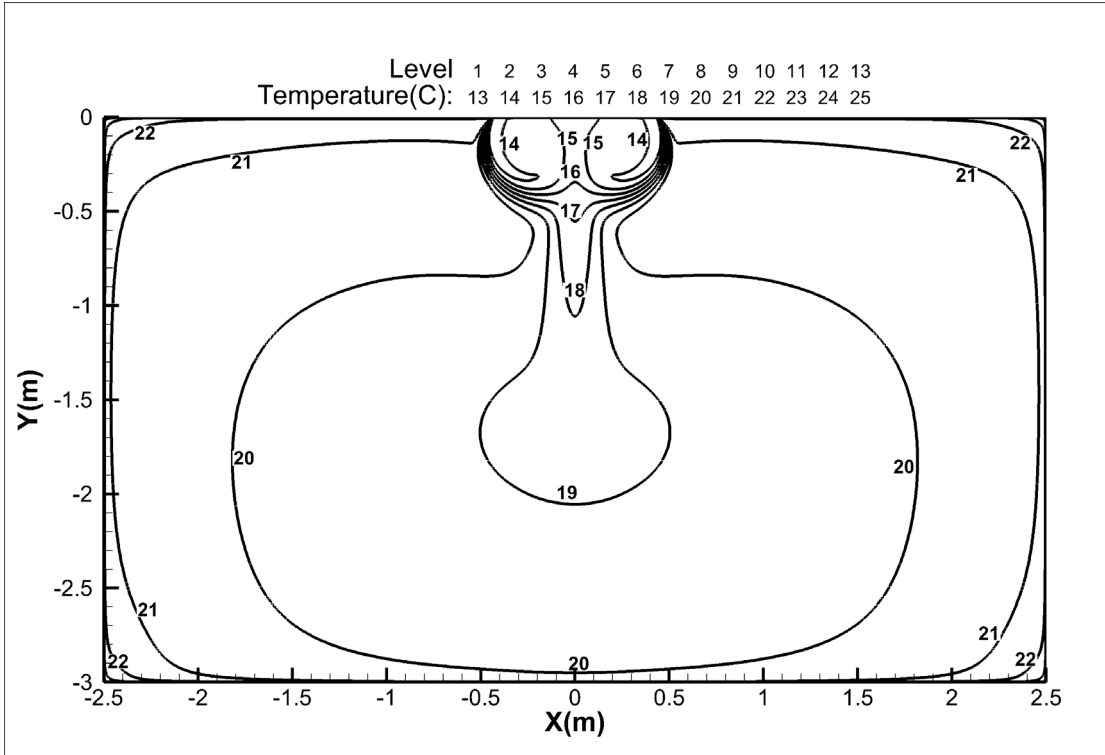

Heating
Discharge Angle 30°

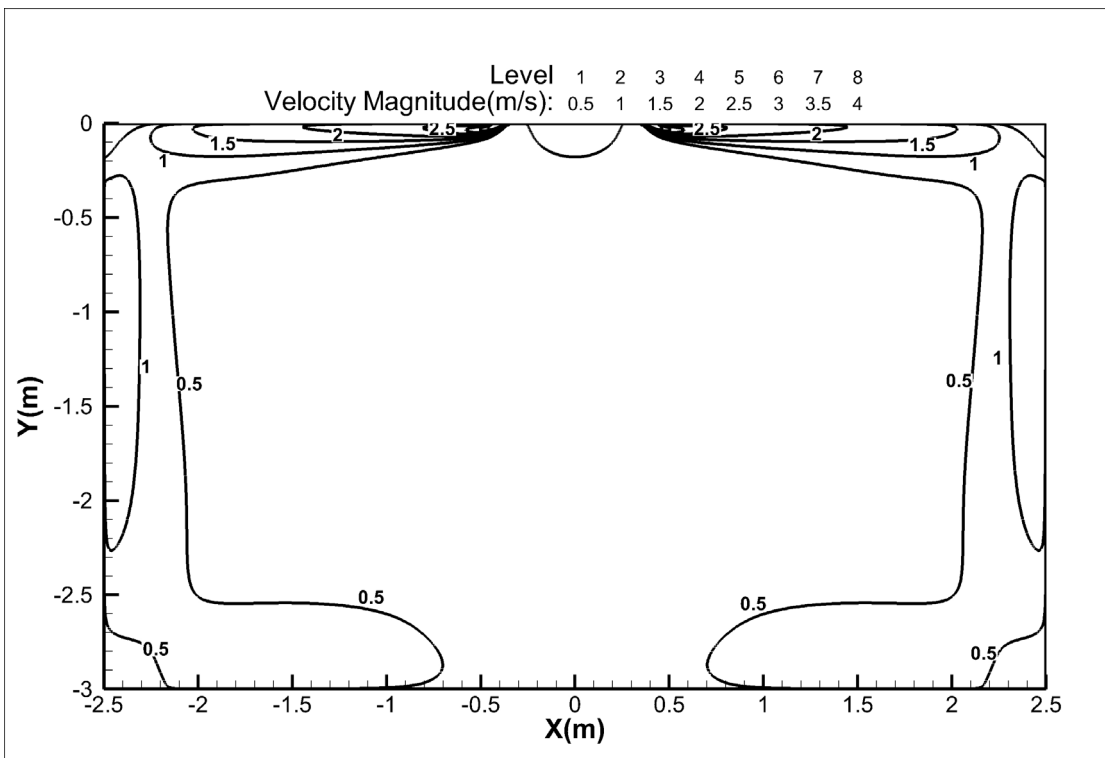
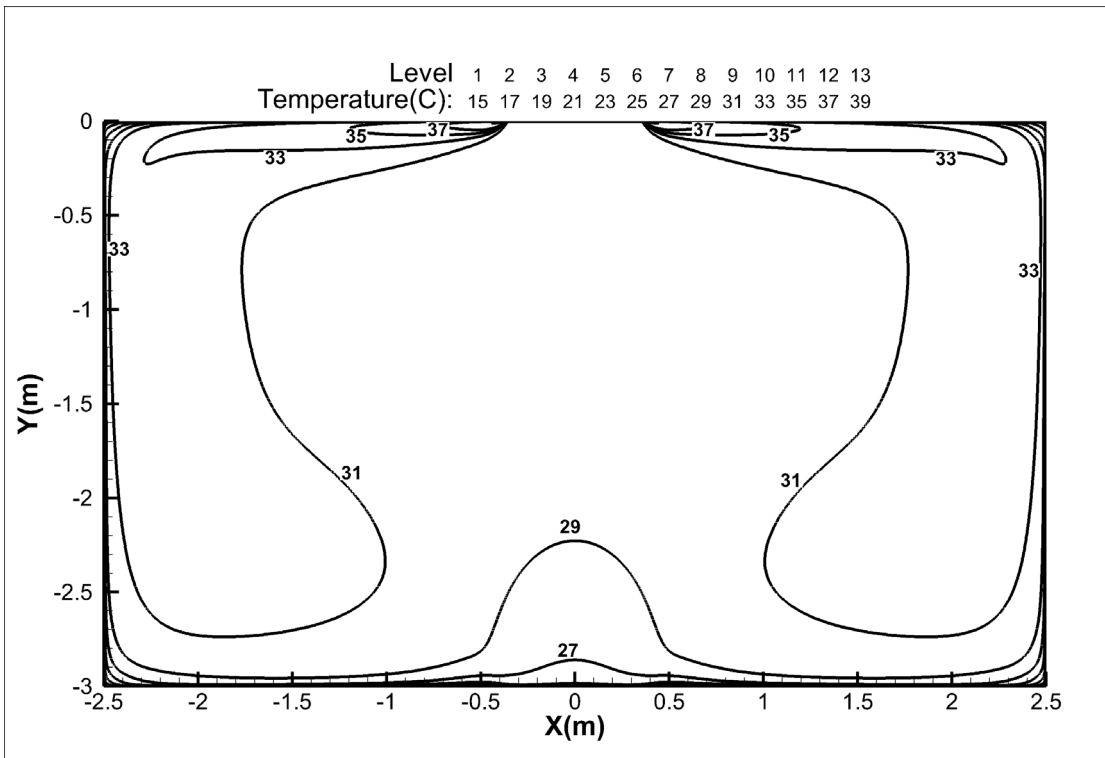

Discharge Angle 60°

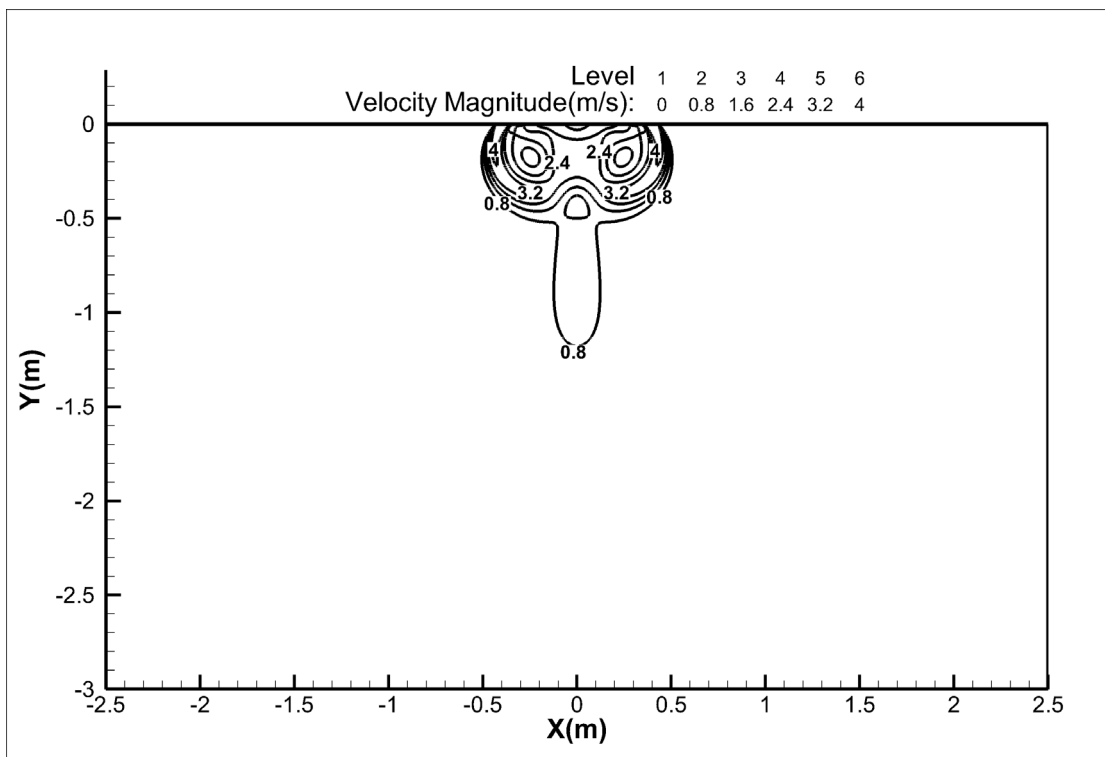
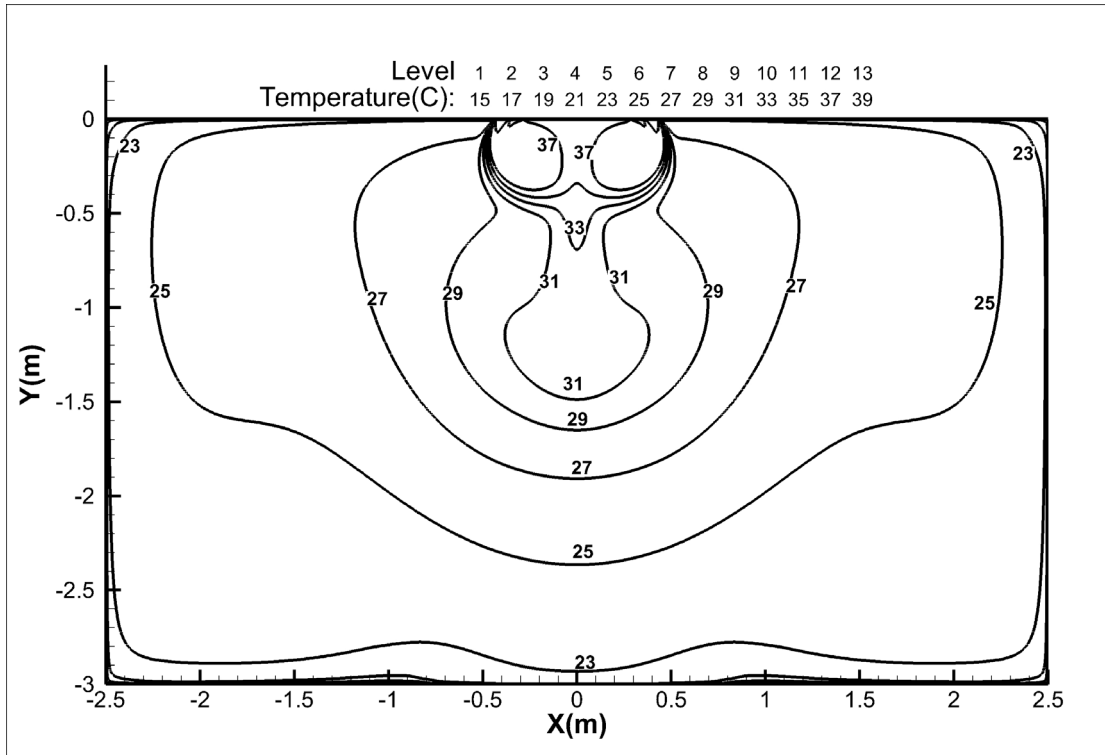

24K

Cooling

Discharge Angle 30°

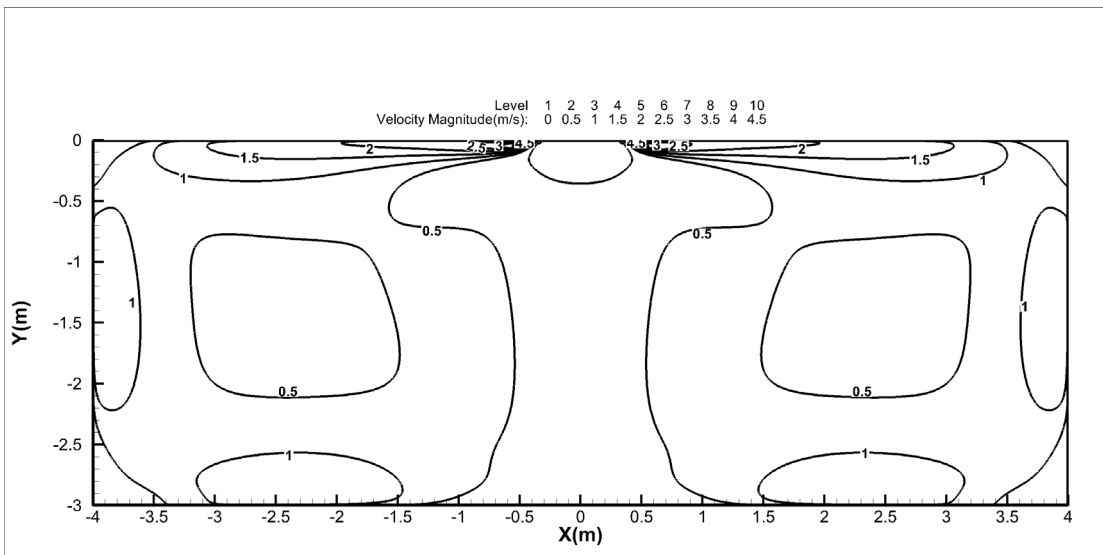
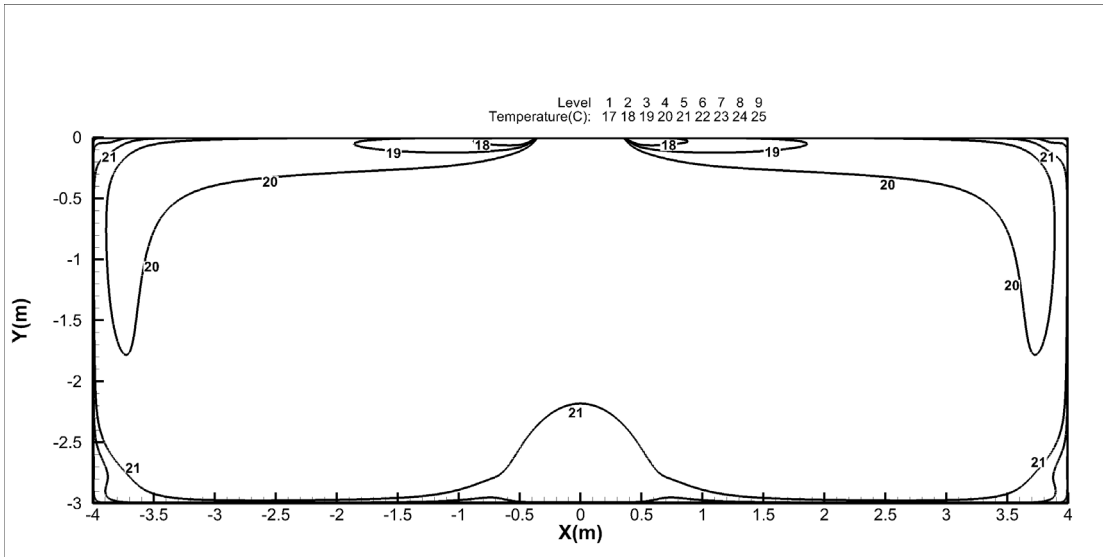

Discharge Angle 60°

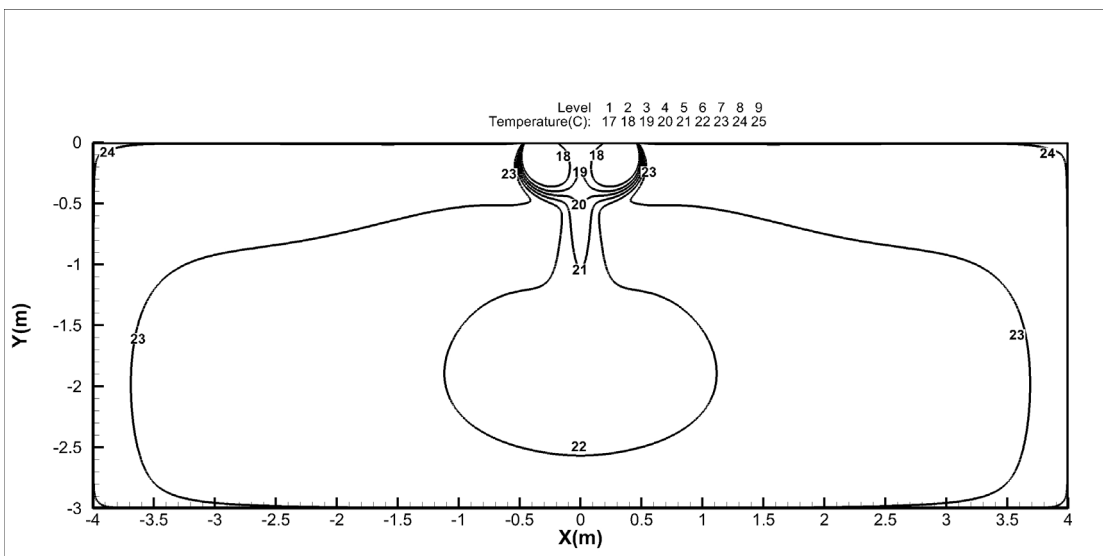

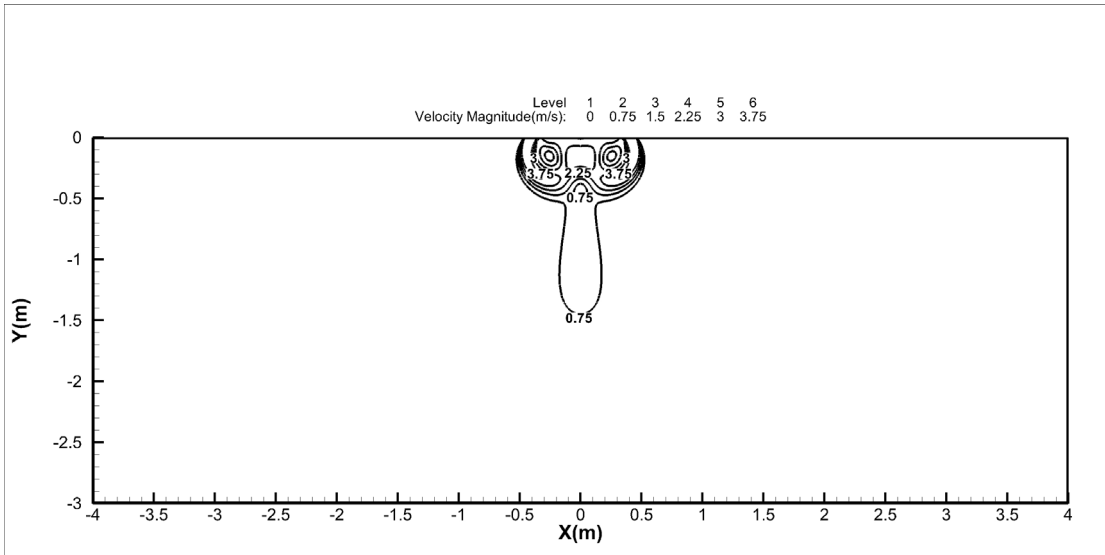

Heating
Discharge Angle 30°

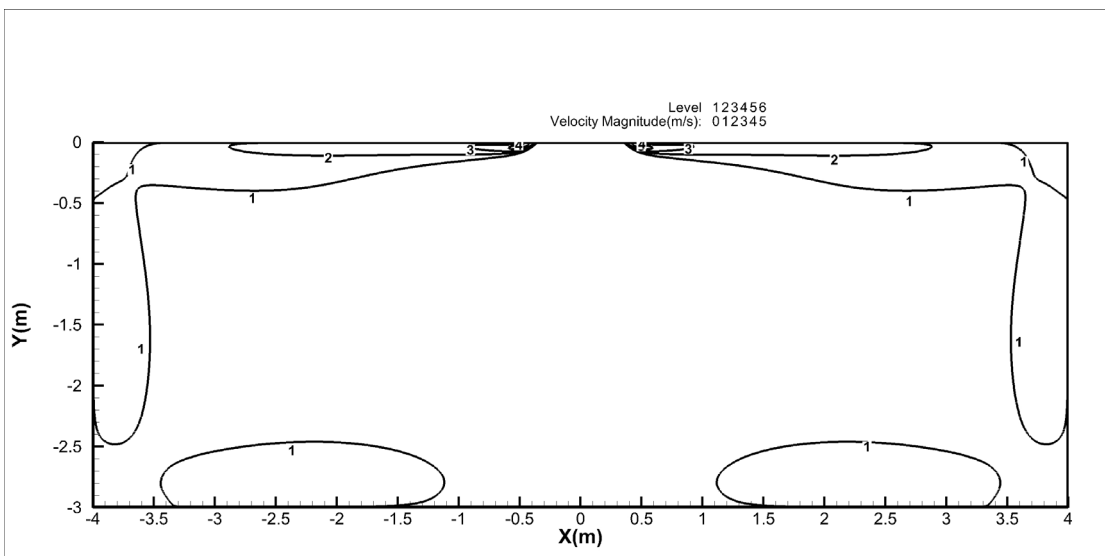
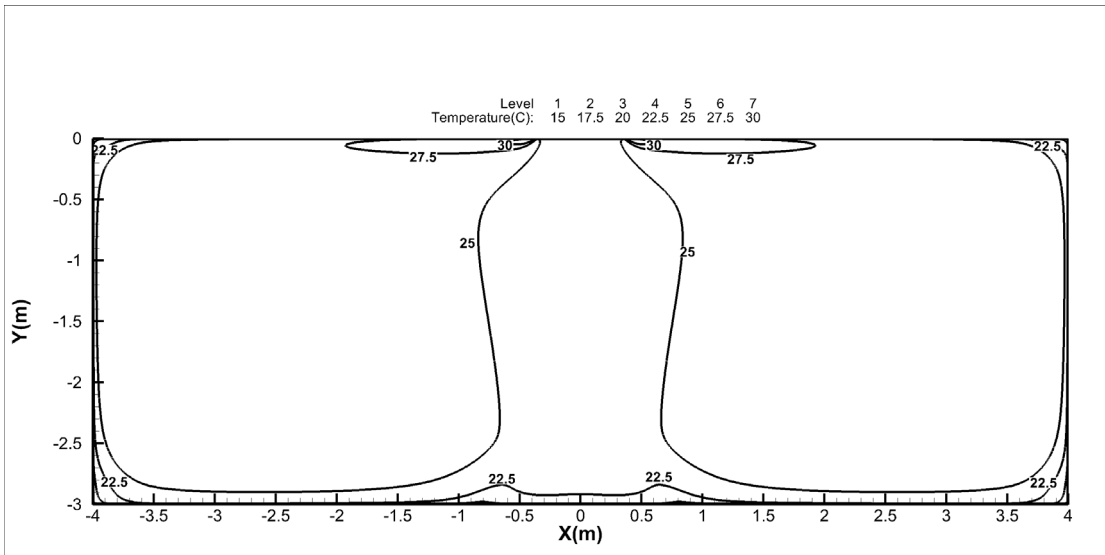

Discharge Angle 60°

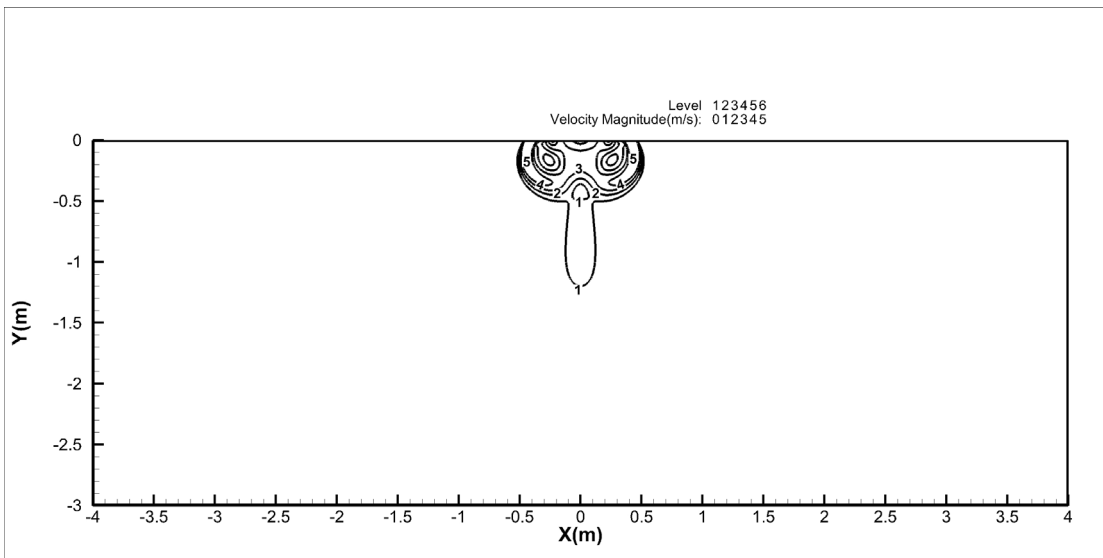
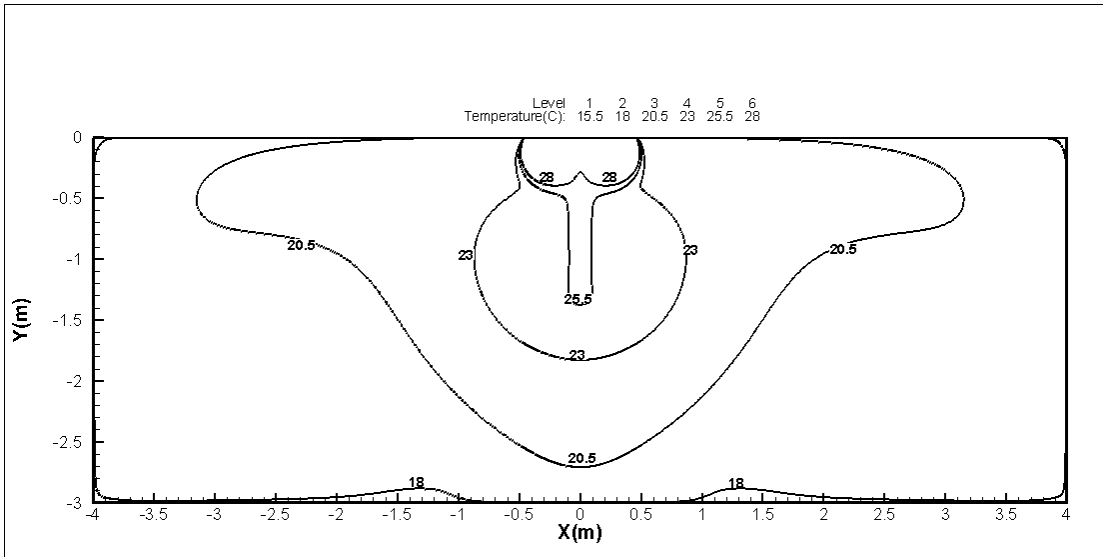

36K

Cooling

Discharge Angle 30°

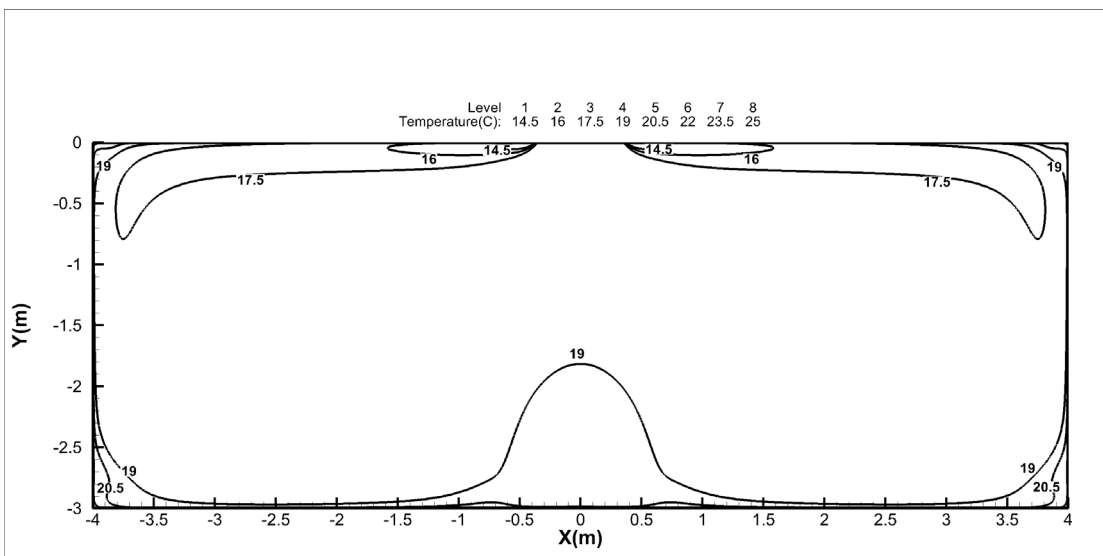

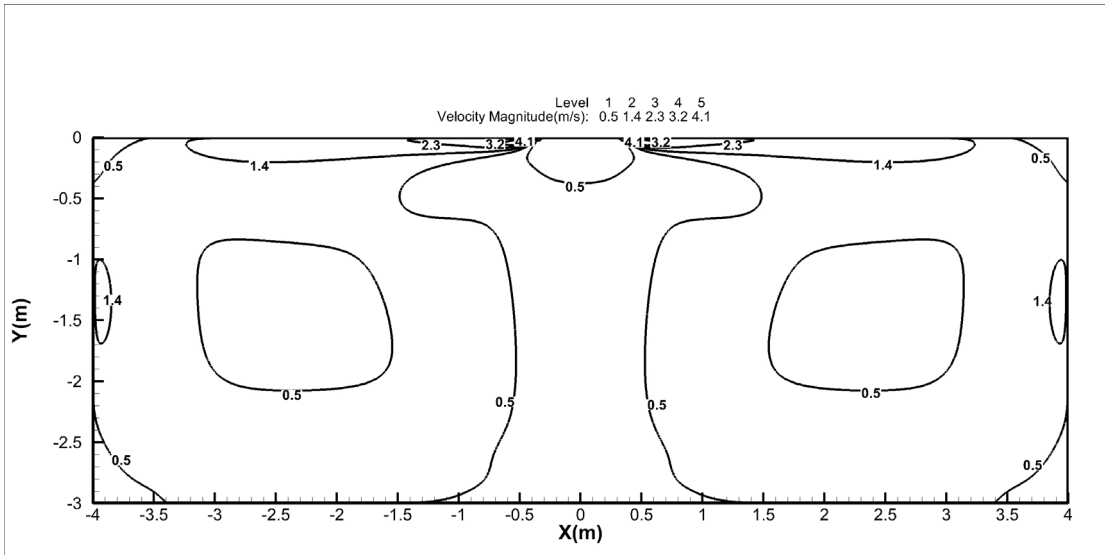

Discharge Angle 60°

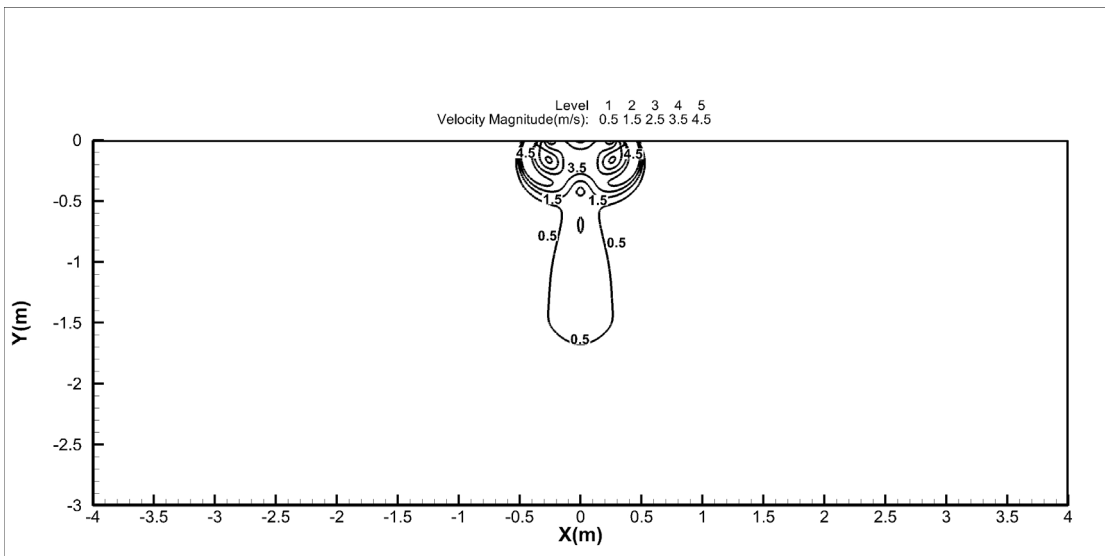
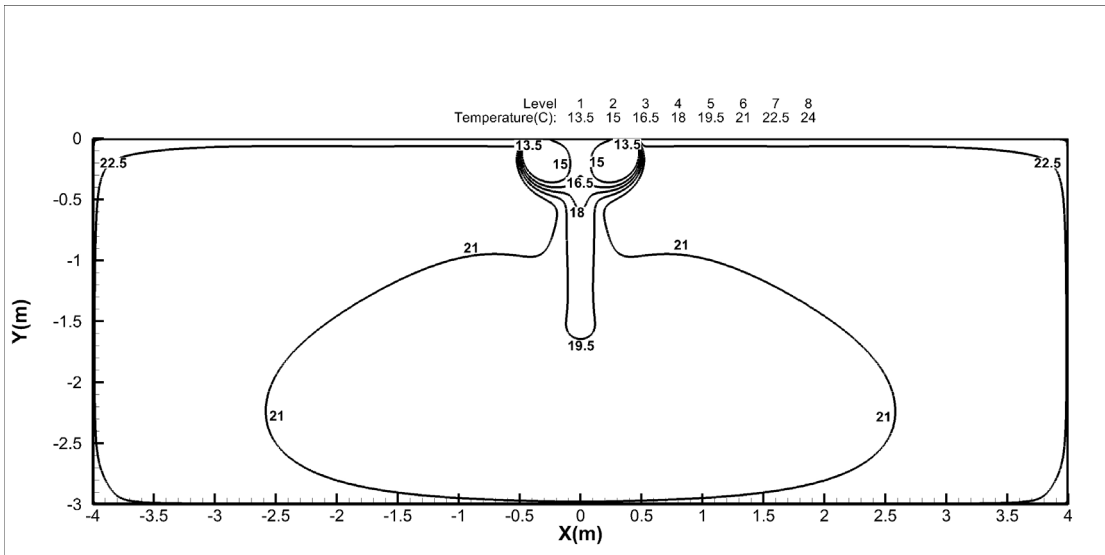

Heating
Discharge Angle 30°

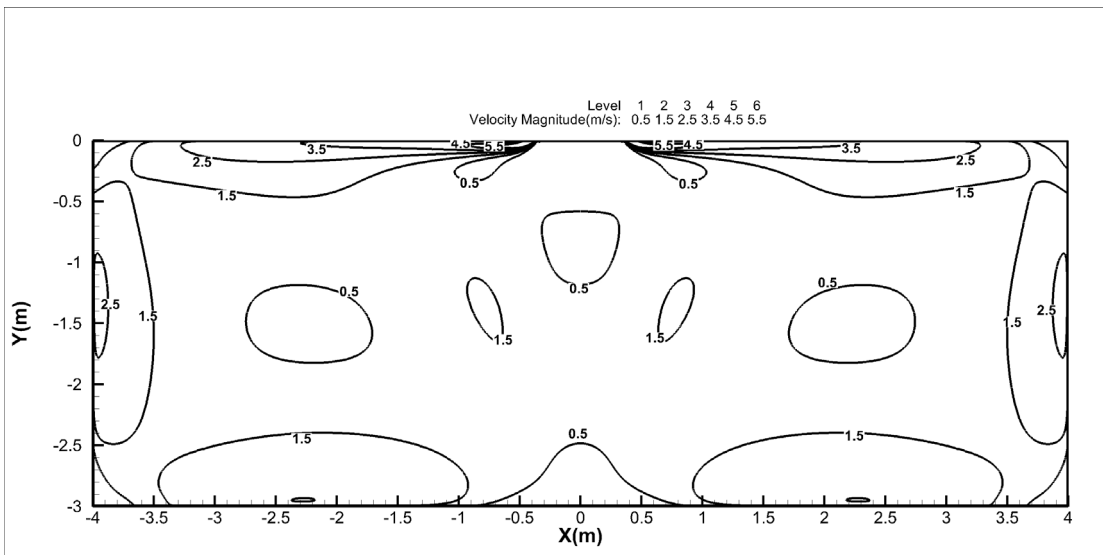
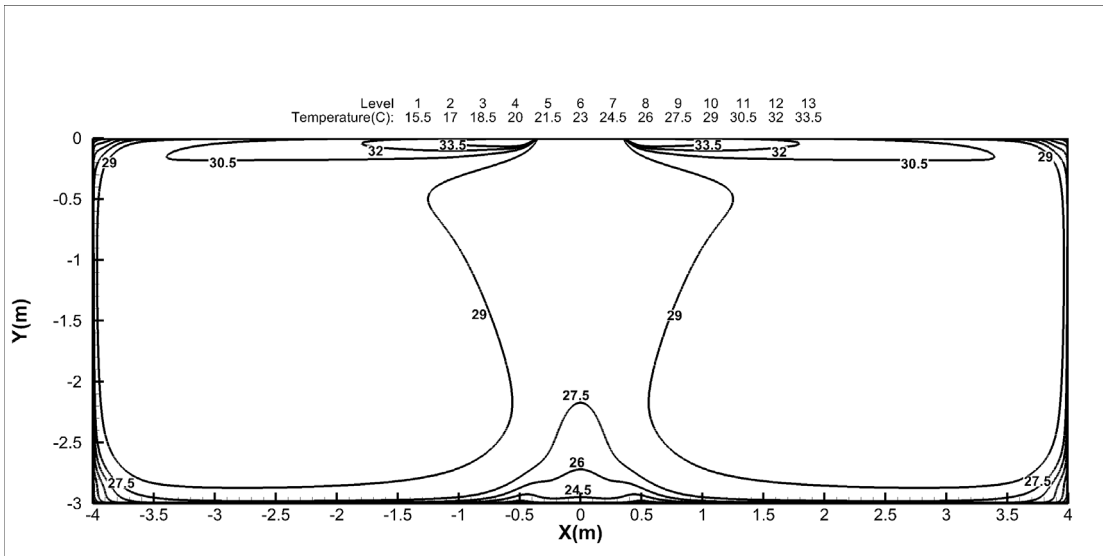

Discharge Angle 60°

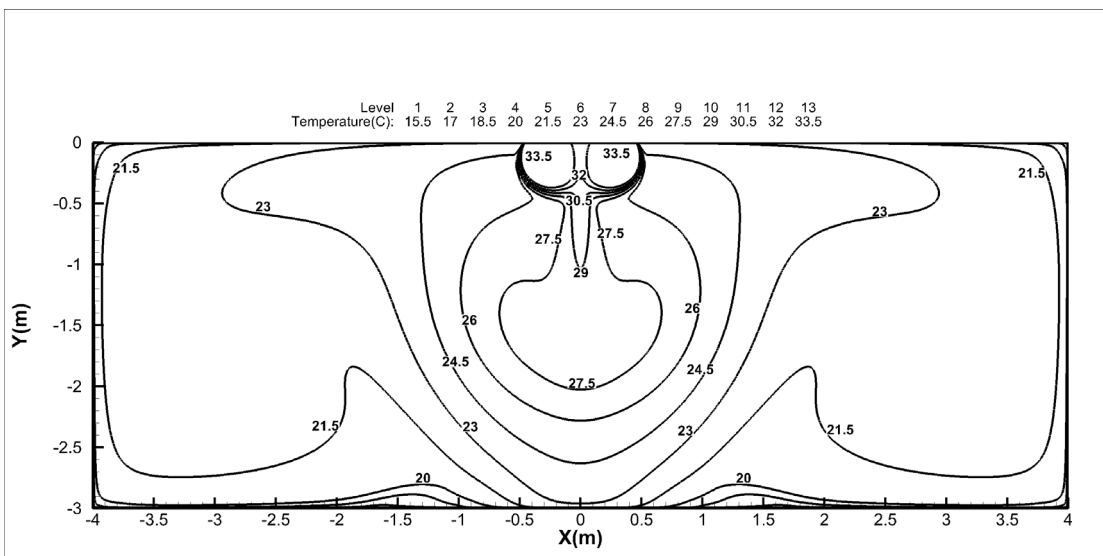

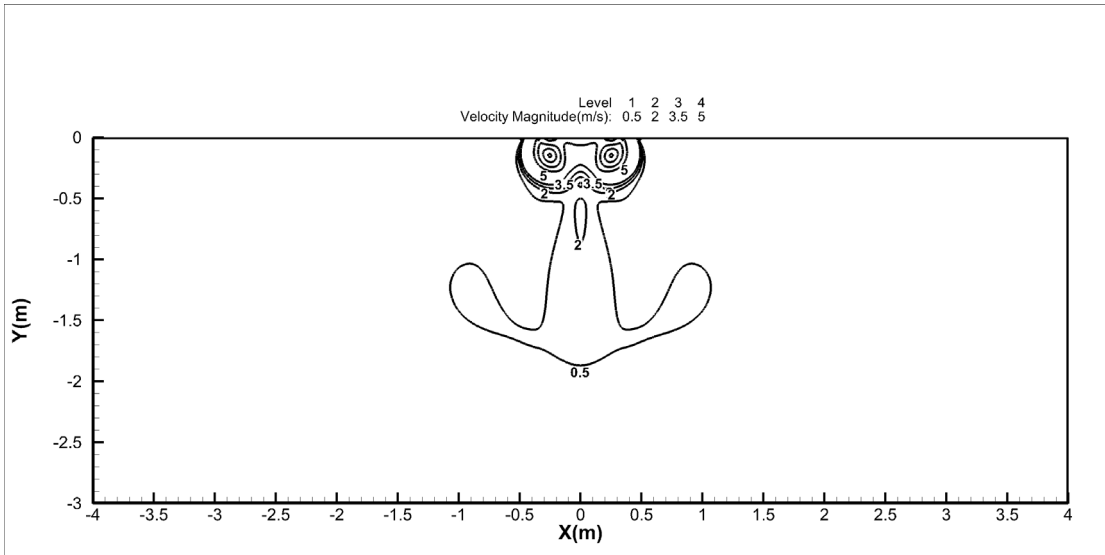

48K

Cooling

Discharge Angle 30°

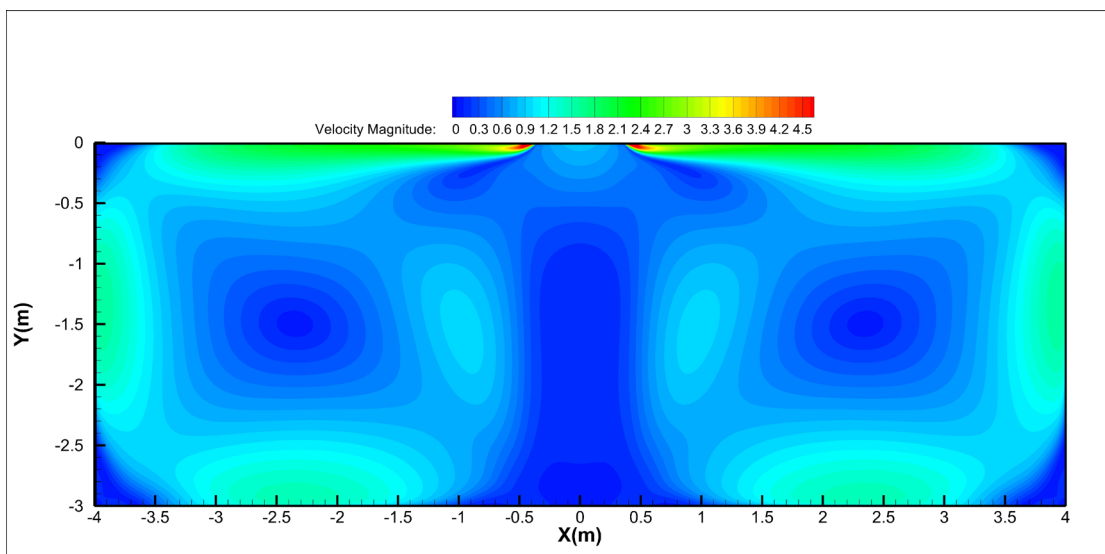
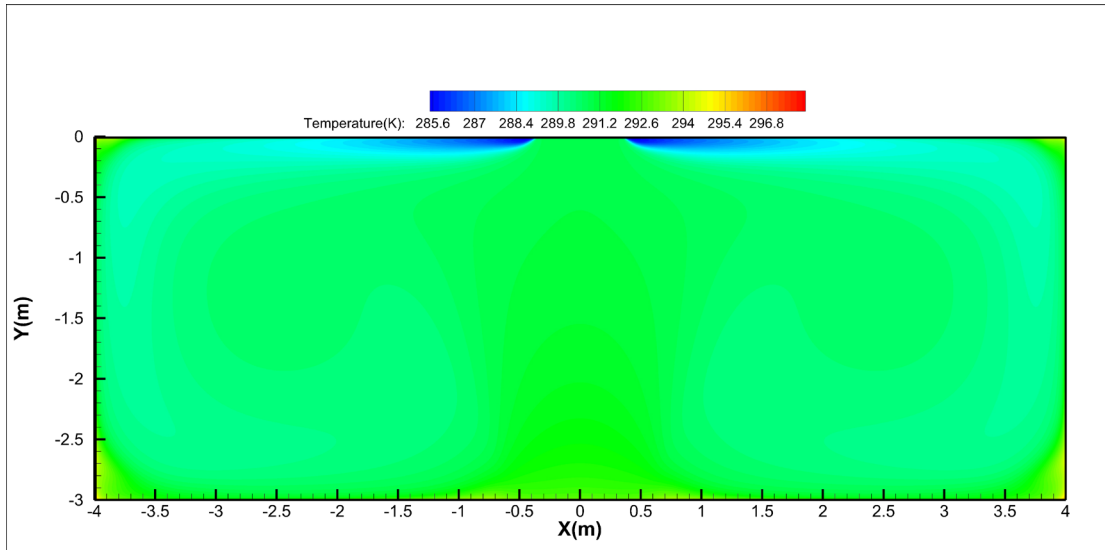

Discharge Angle 60°

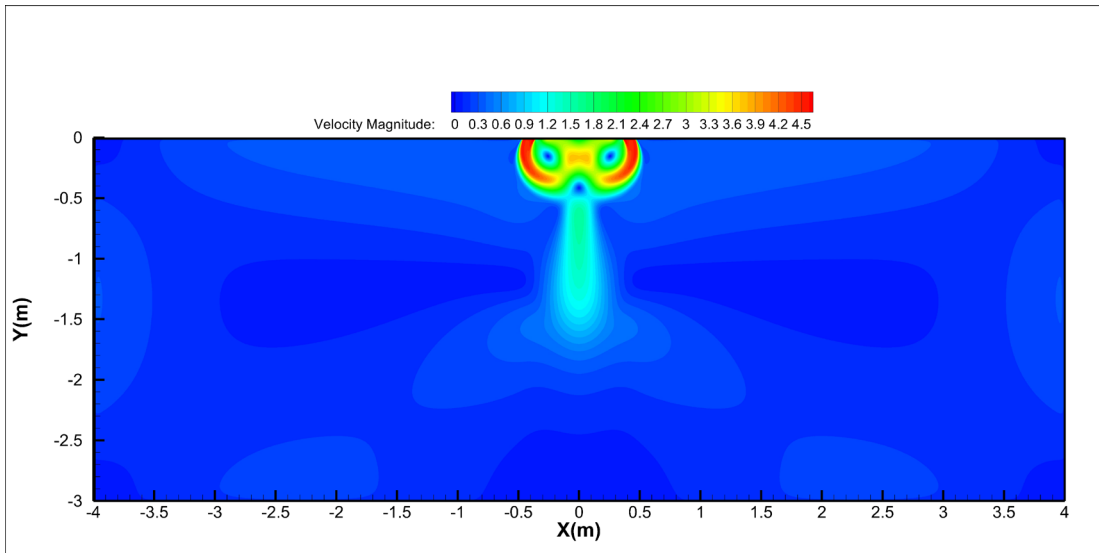
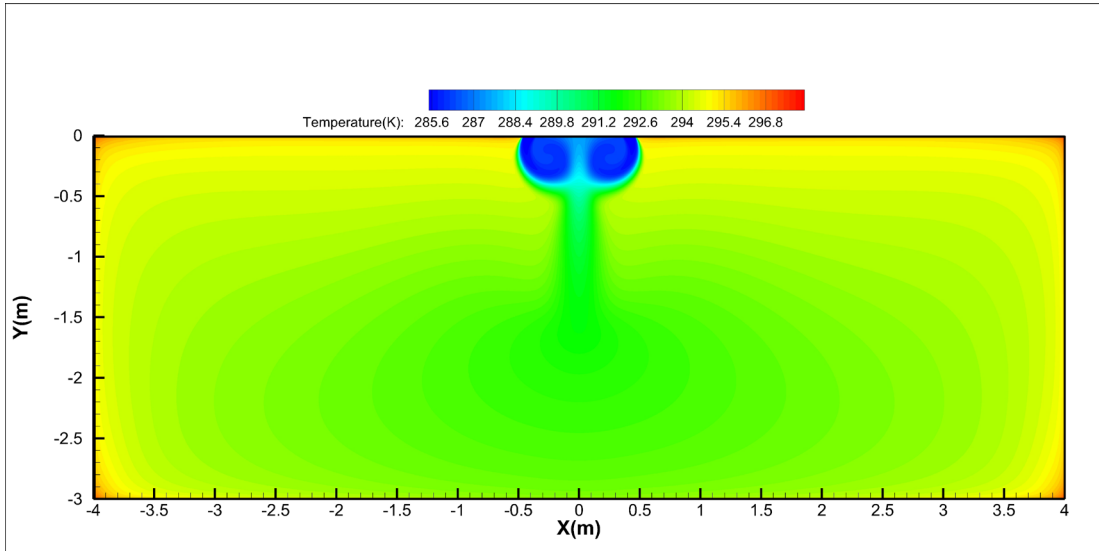

Heating
Discharge Angle 30°

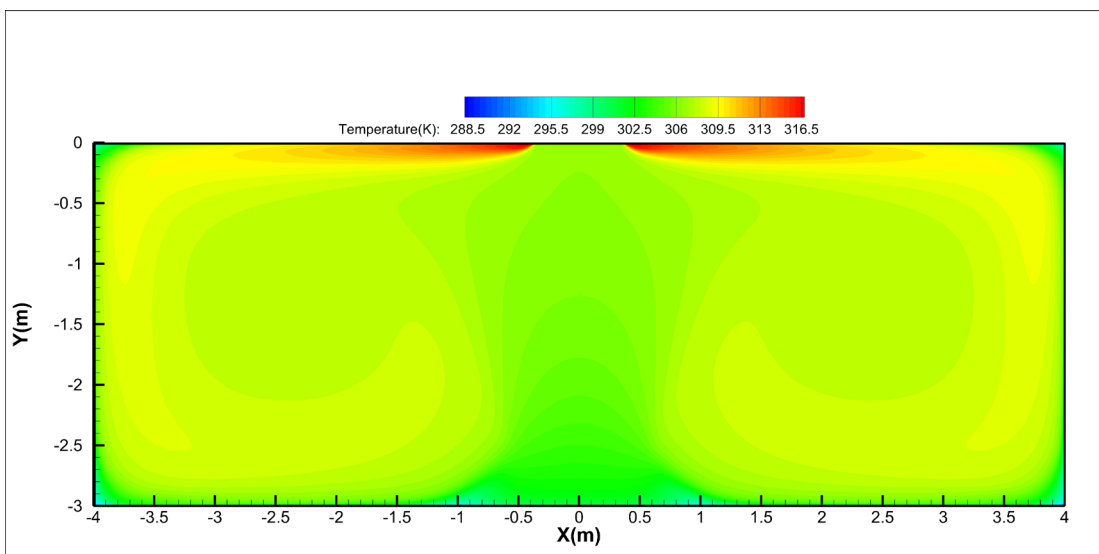

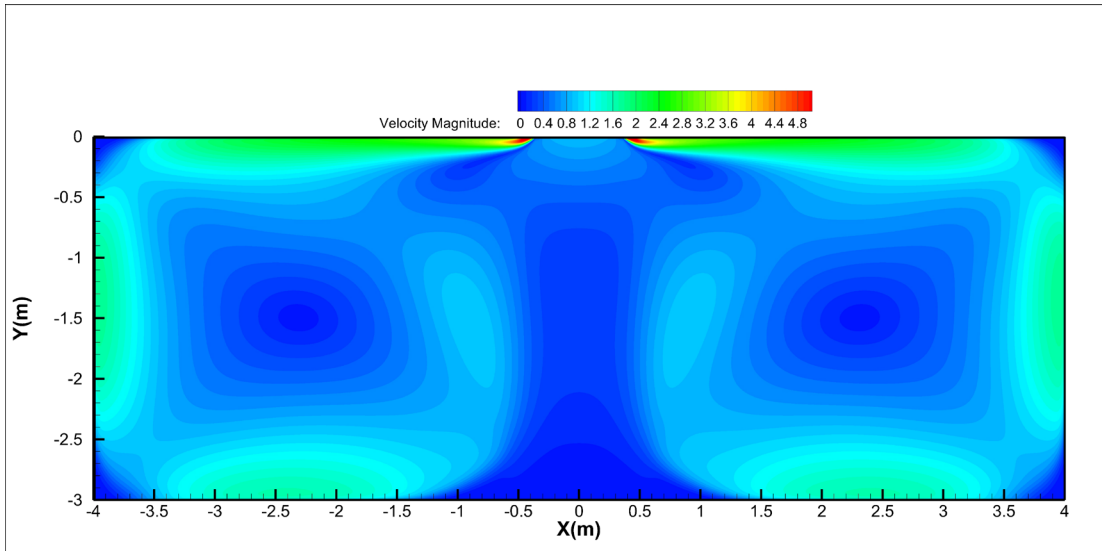

Discharge Angle 60°

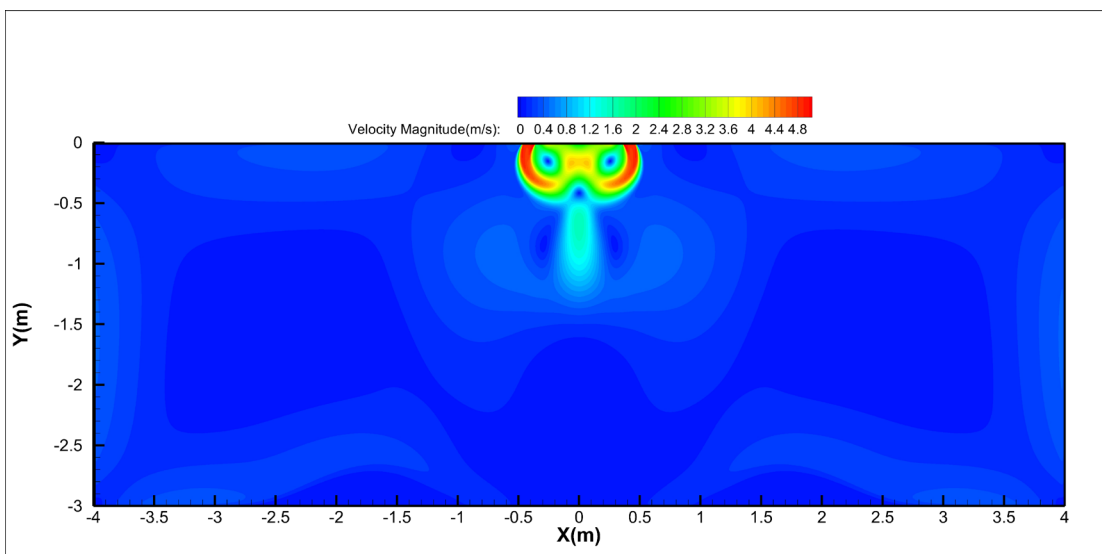
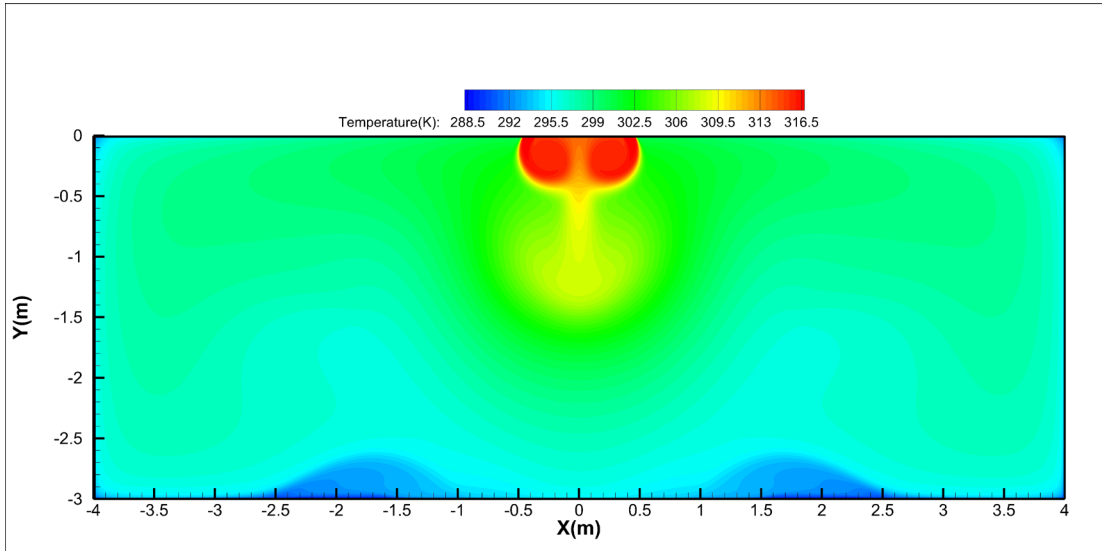

Ceiling-floor Units

18K

Cooling

Ceiling installation:

Discharge Angle 30°

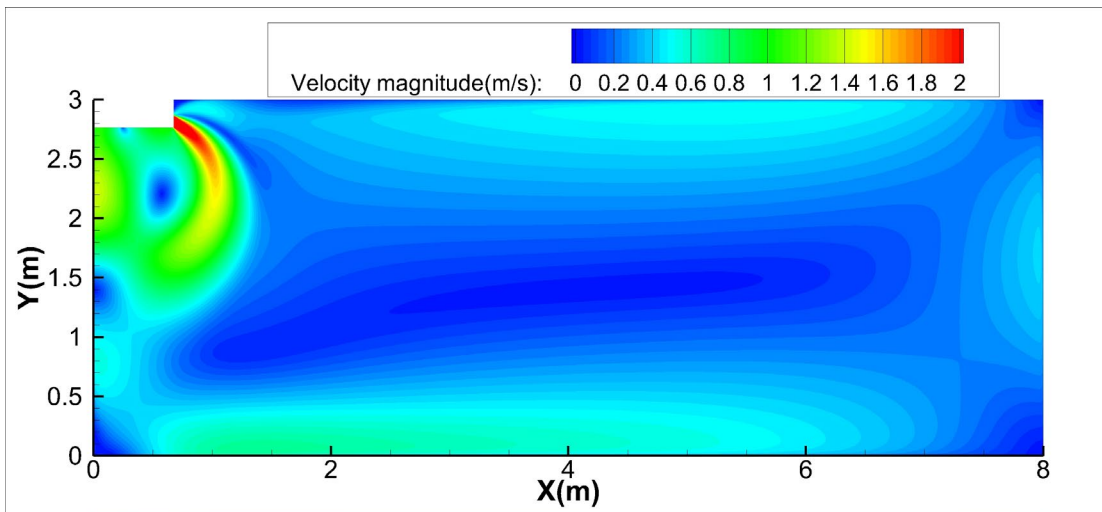
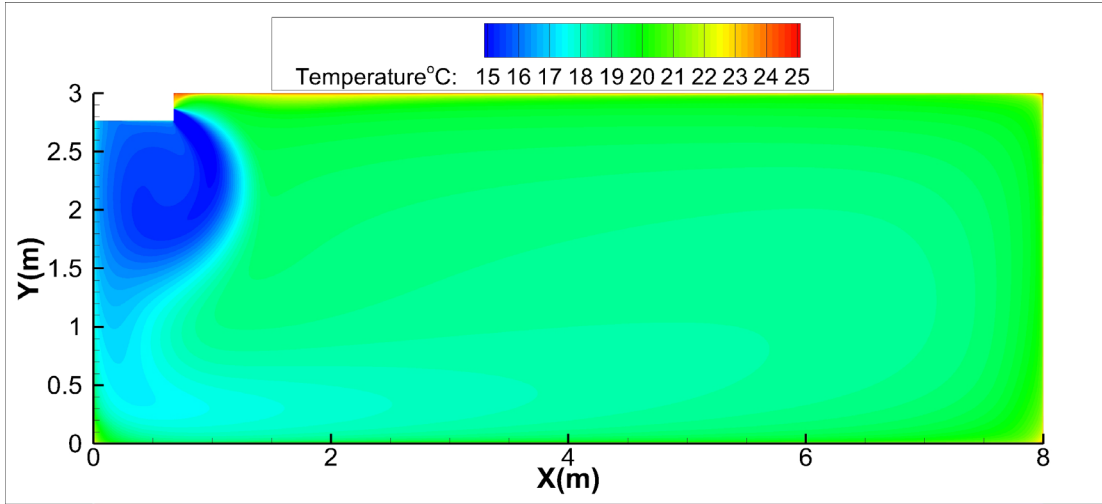

Discharge Angle 60°

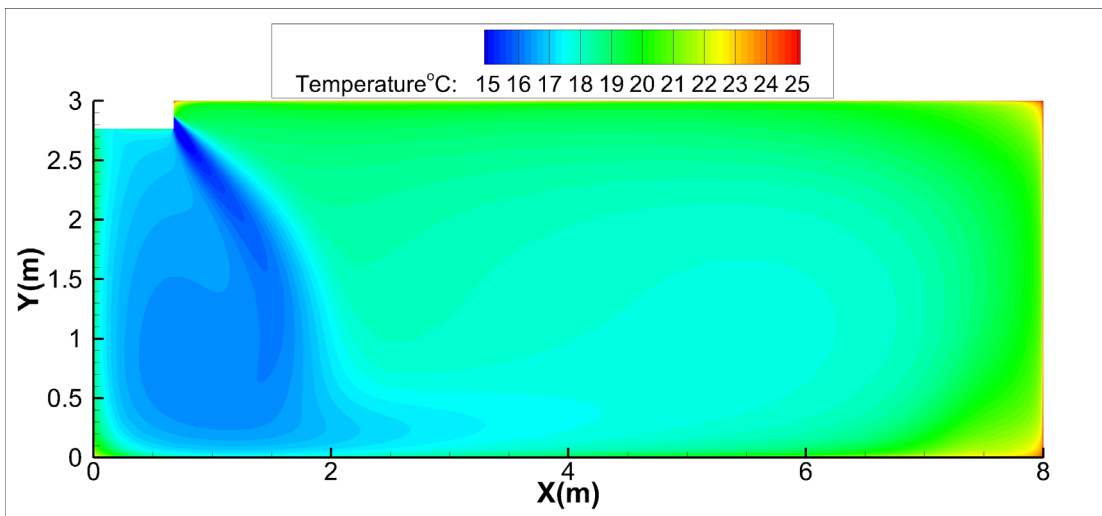

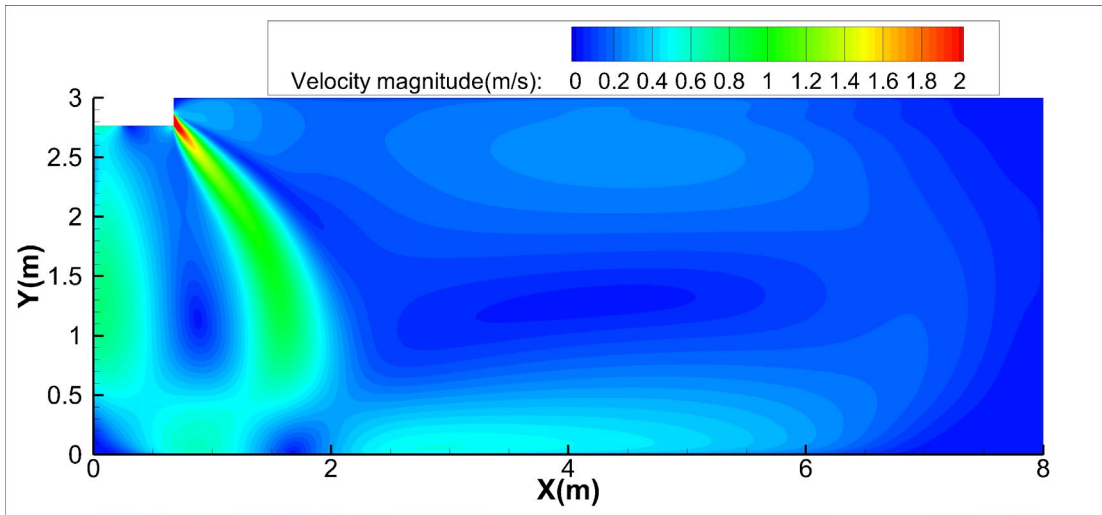

Floor installation:
Discharge Angle 30°

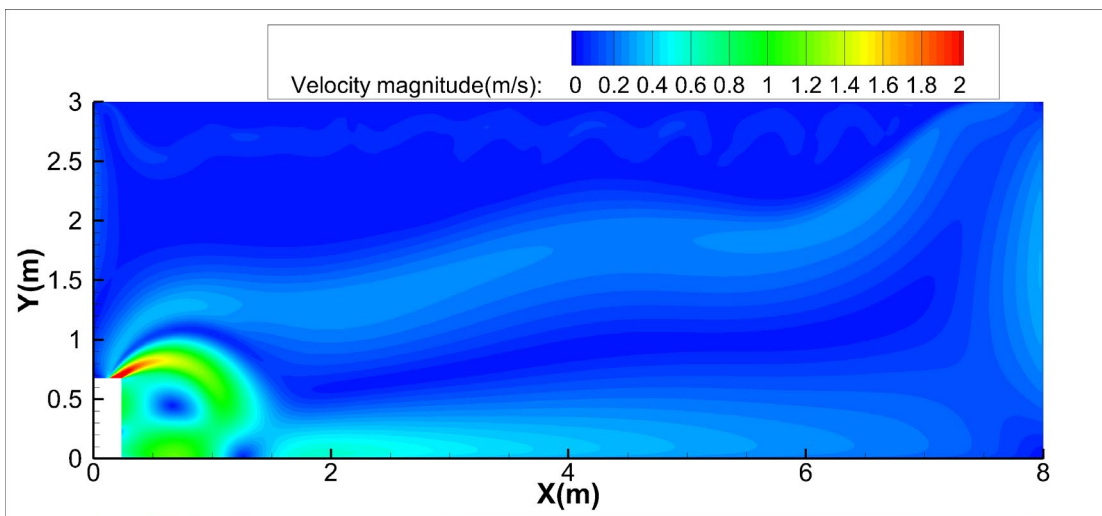
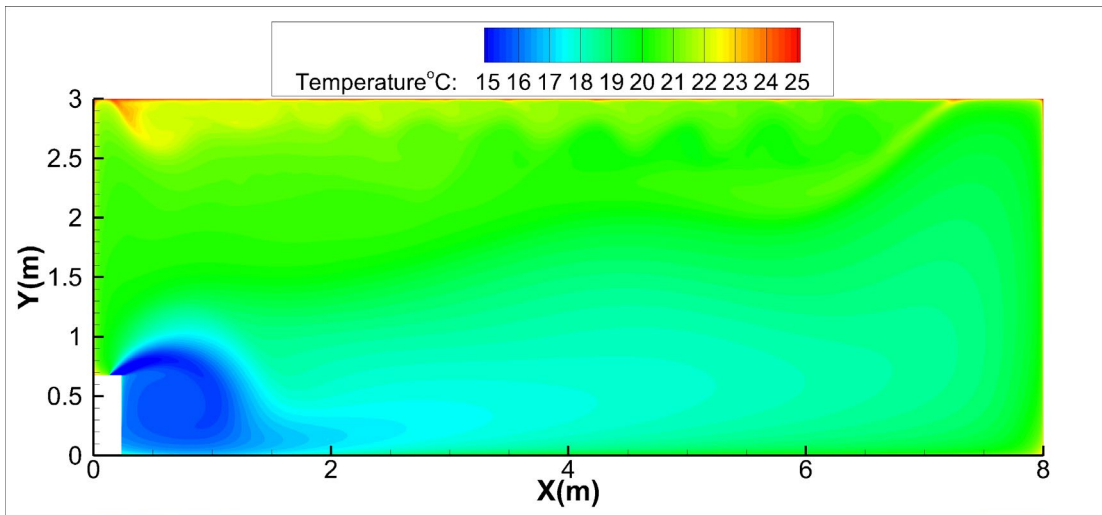

Discharge Angle 60°

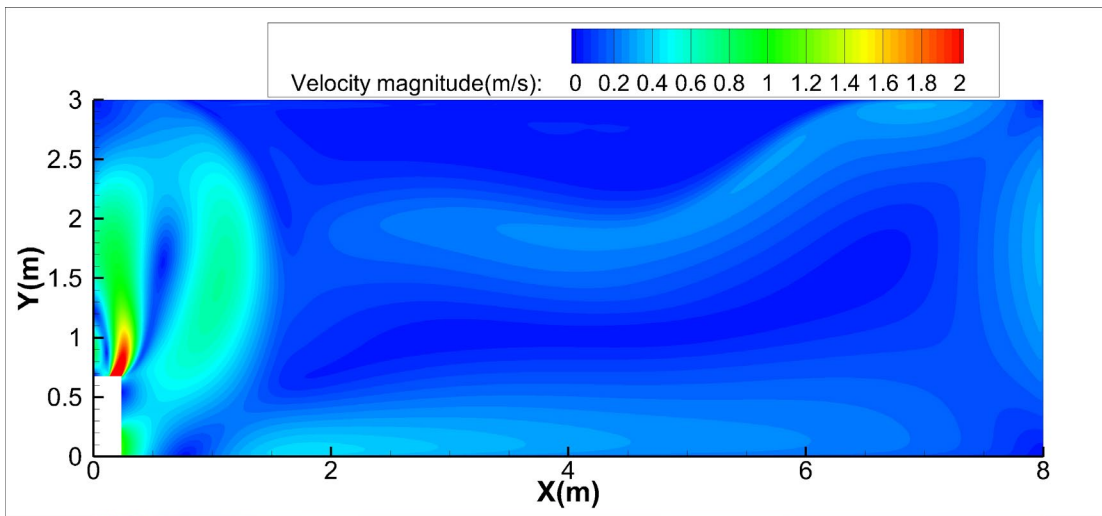
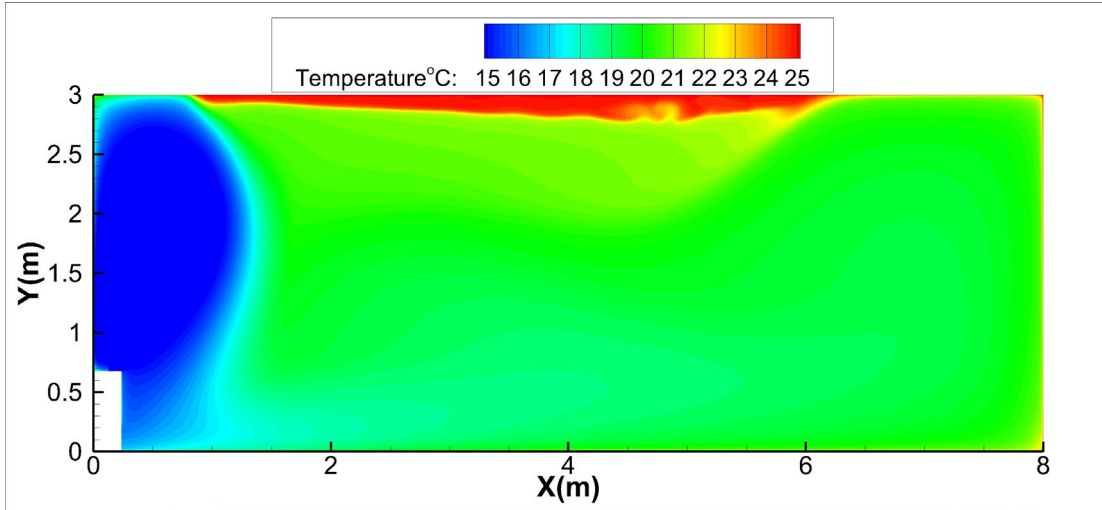

Heating

Ceiling installation:

Discharge Angle 30°

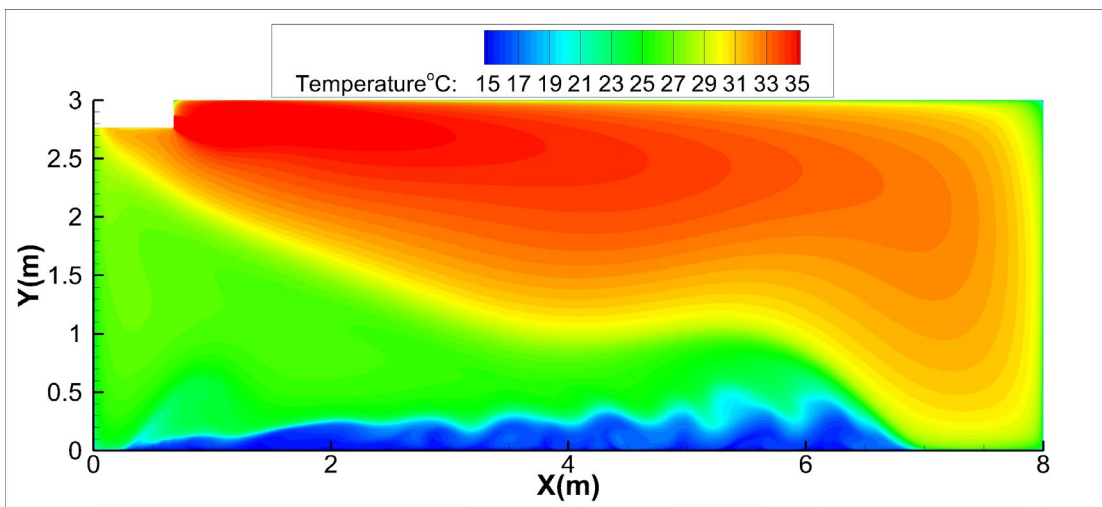

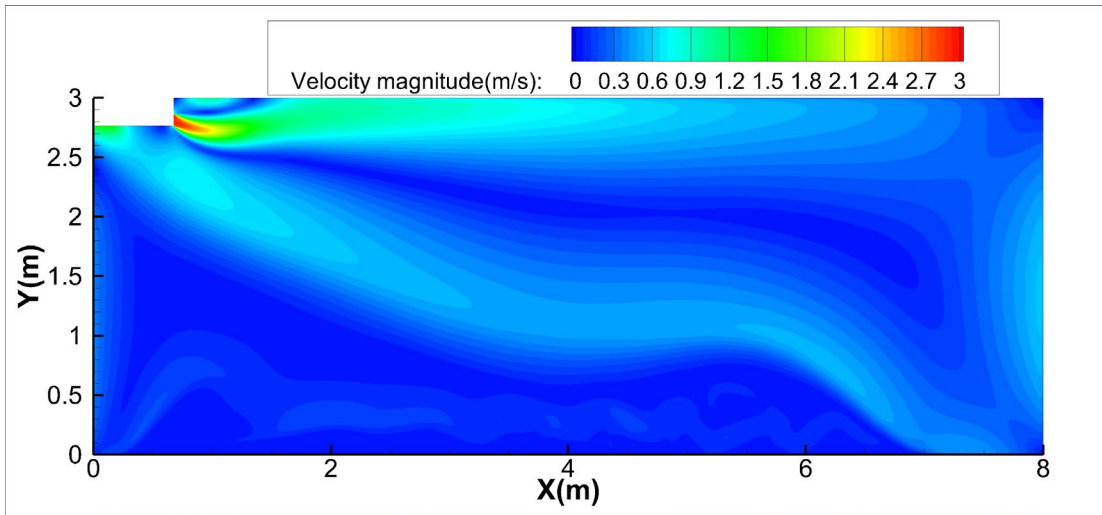

Discharge Angle 60°

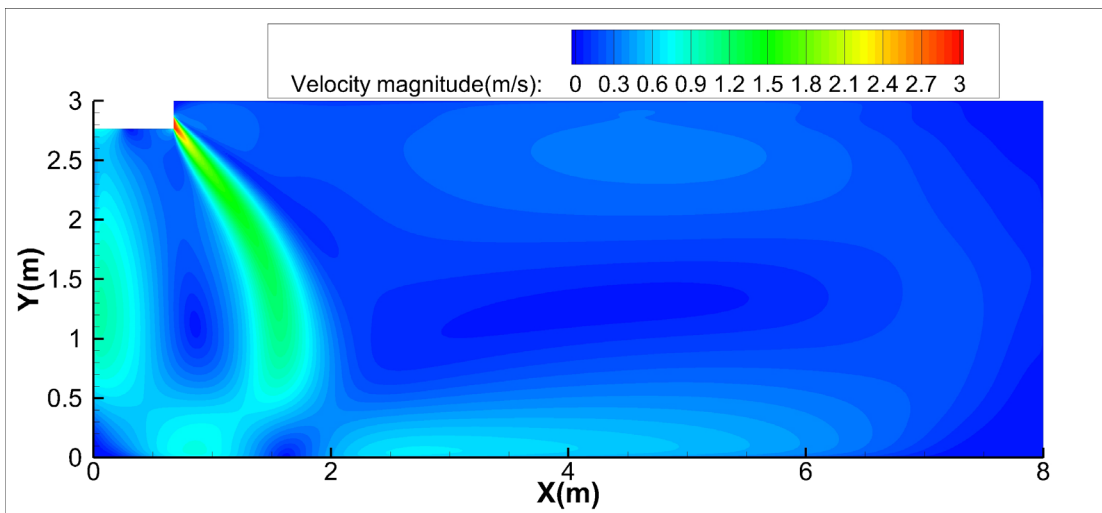
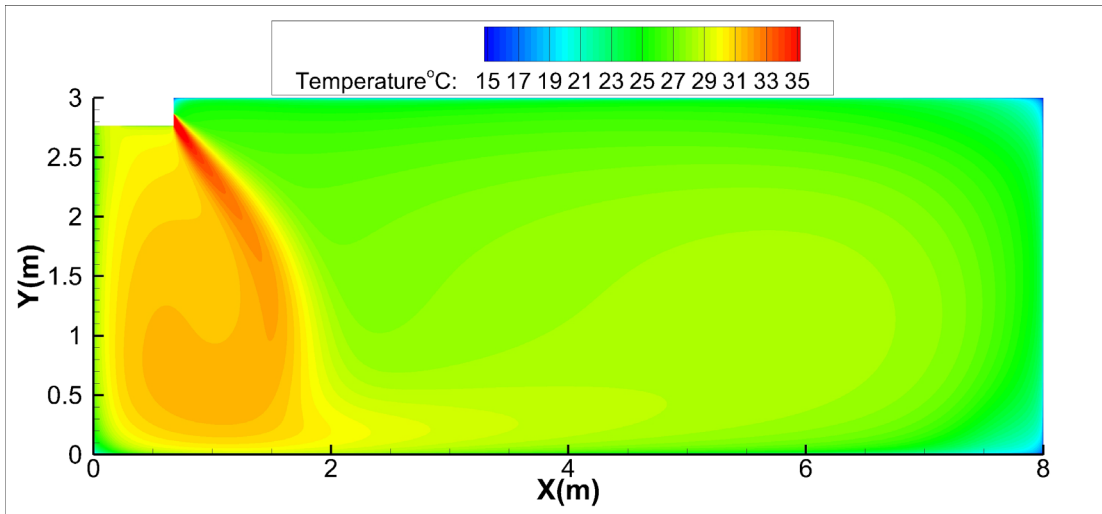

Floor installation:
Discharge Angle 30°

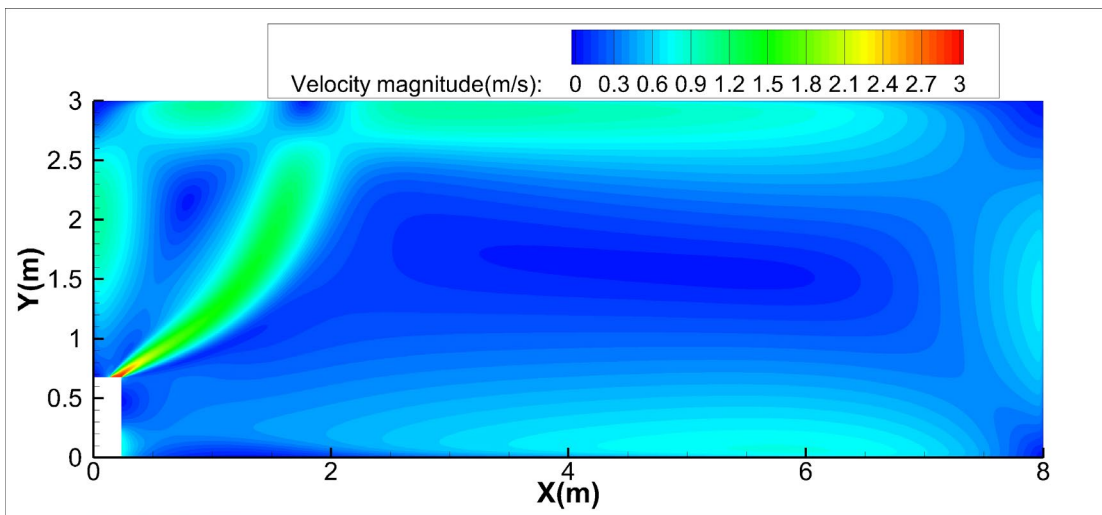
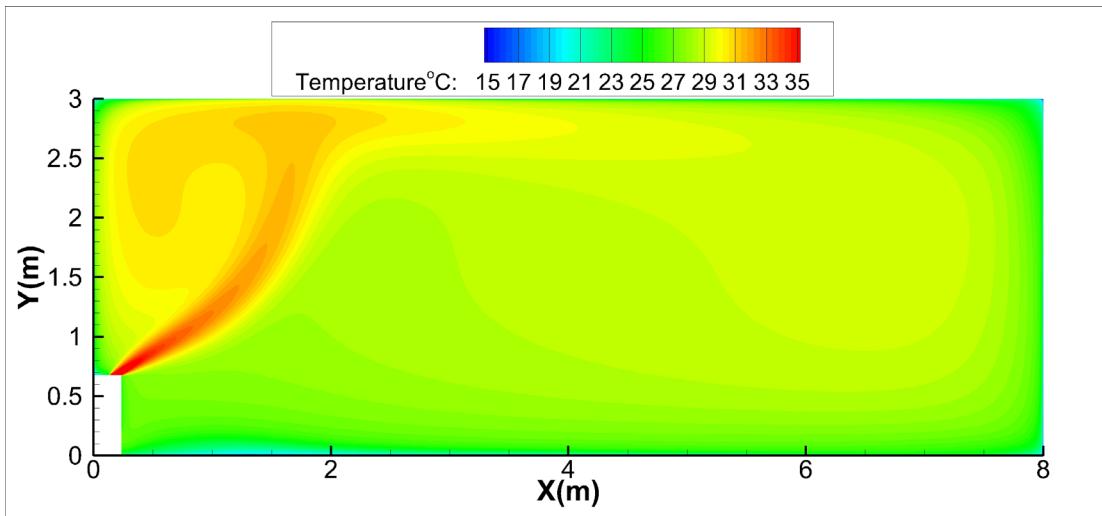

Discharge Angle 60°

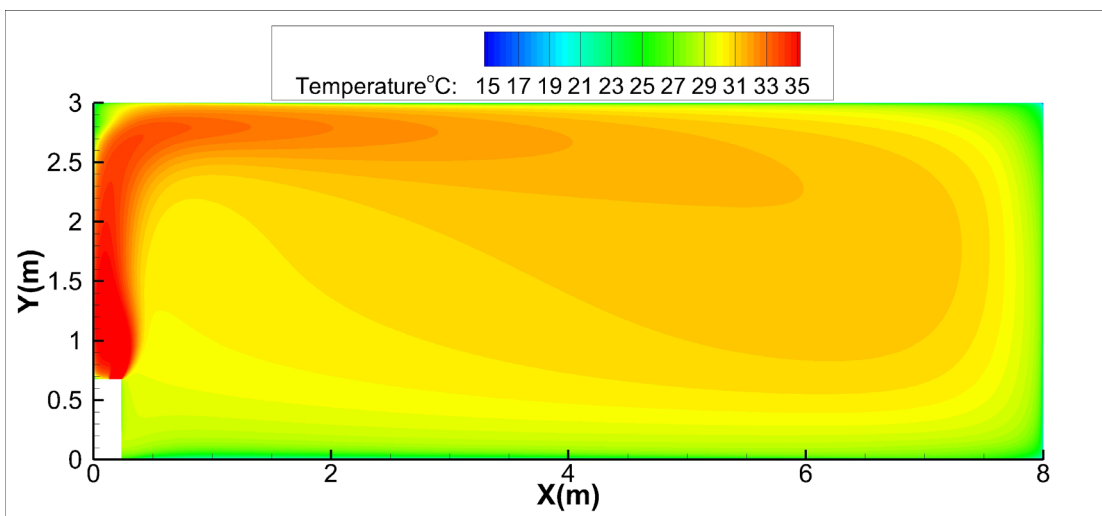

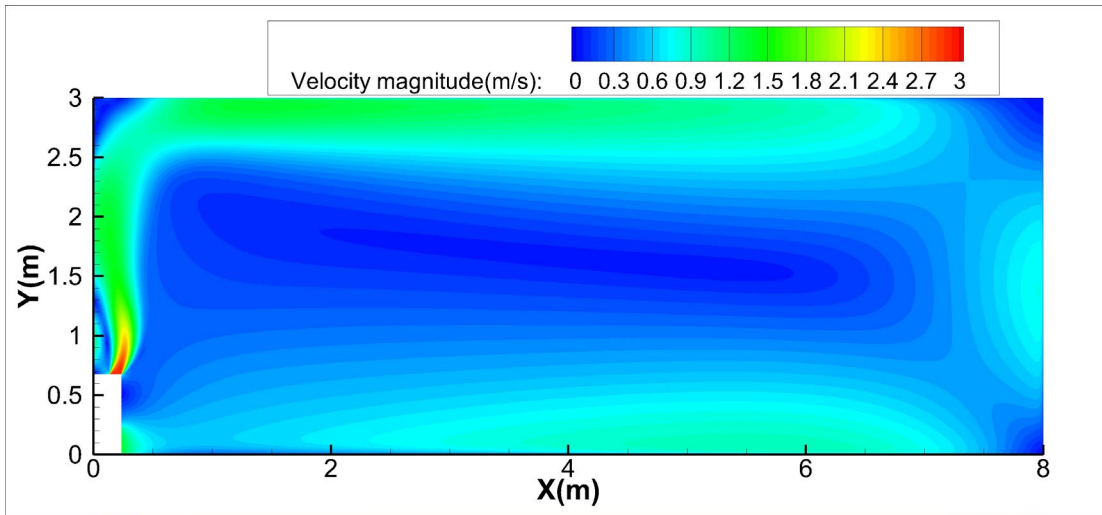

24K
 Cooling
 Ceiling installation:
 Discharge Angle 30°

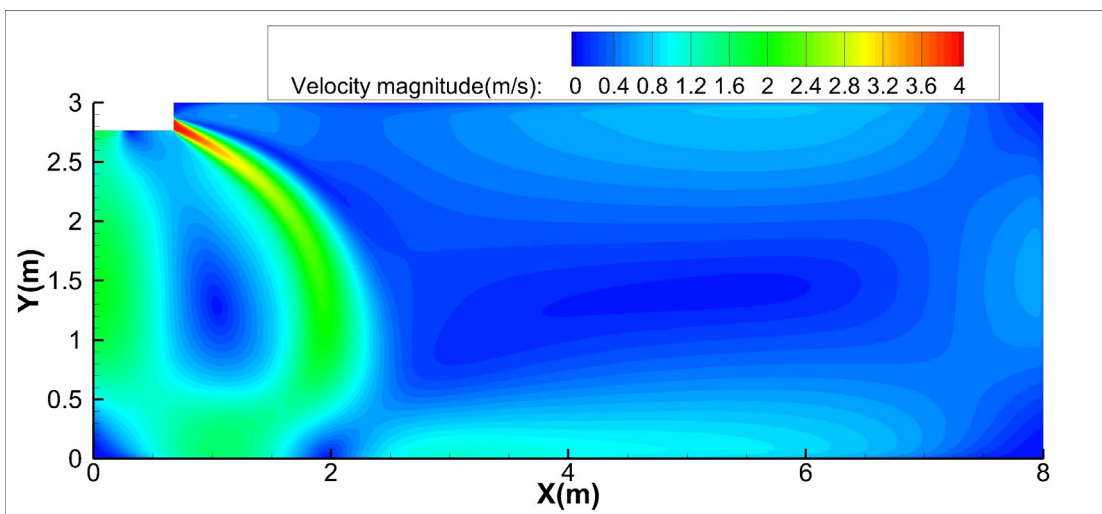
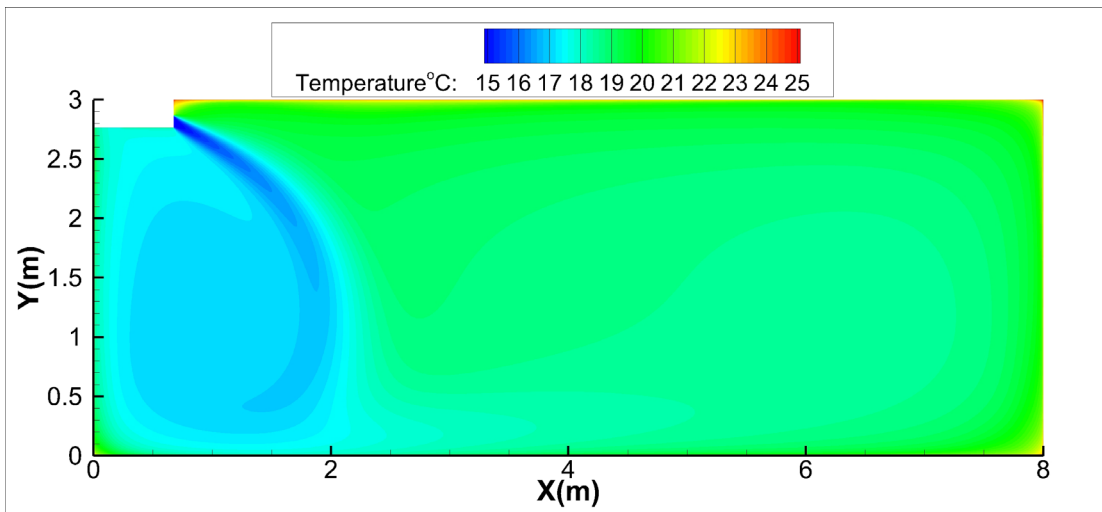

Discharge Angle 60°

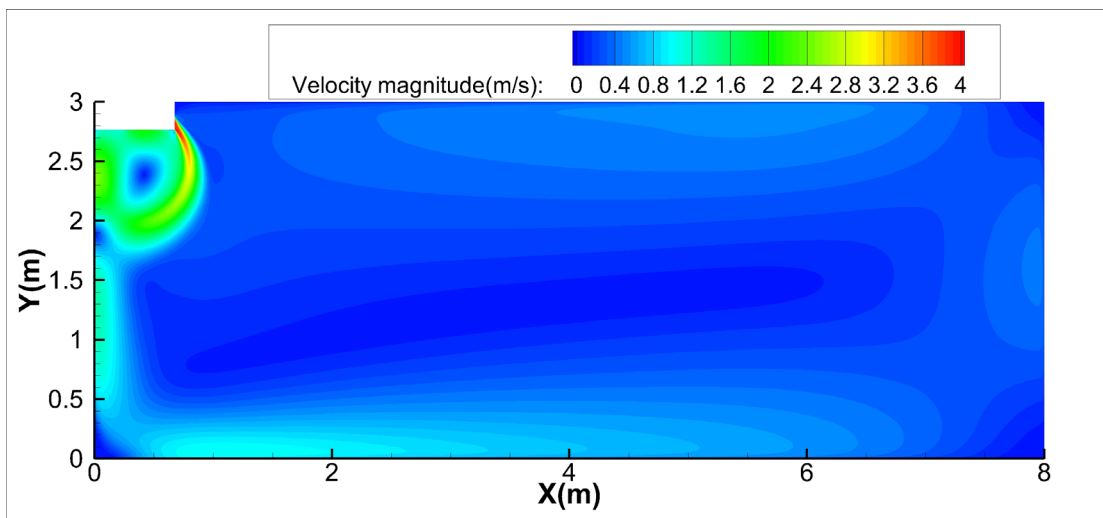
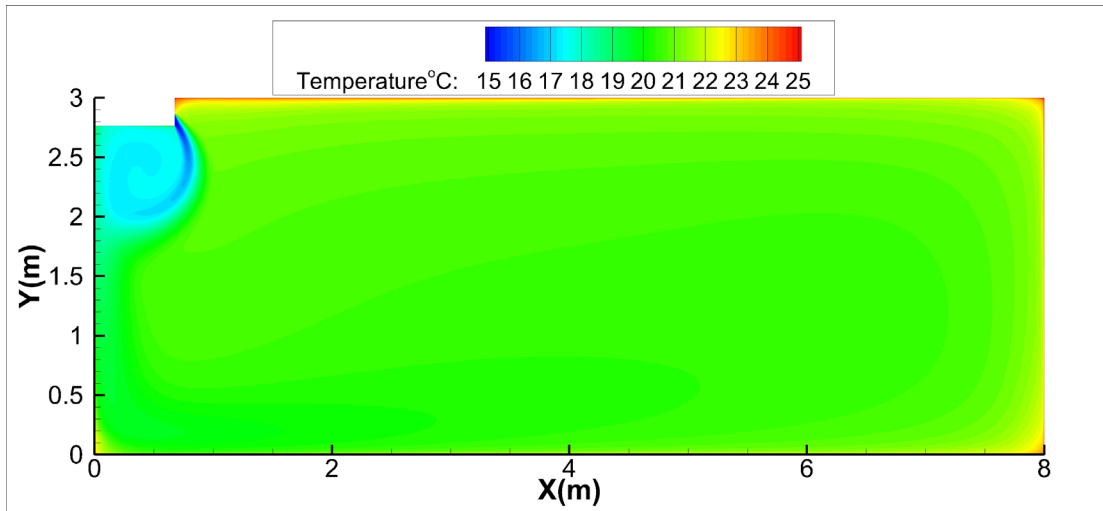

Floor installation:
Discharge Angle 30°

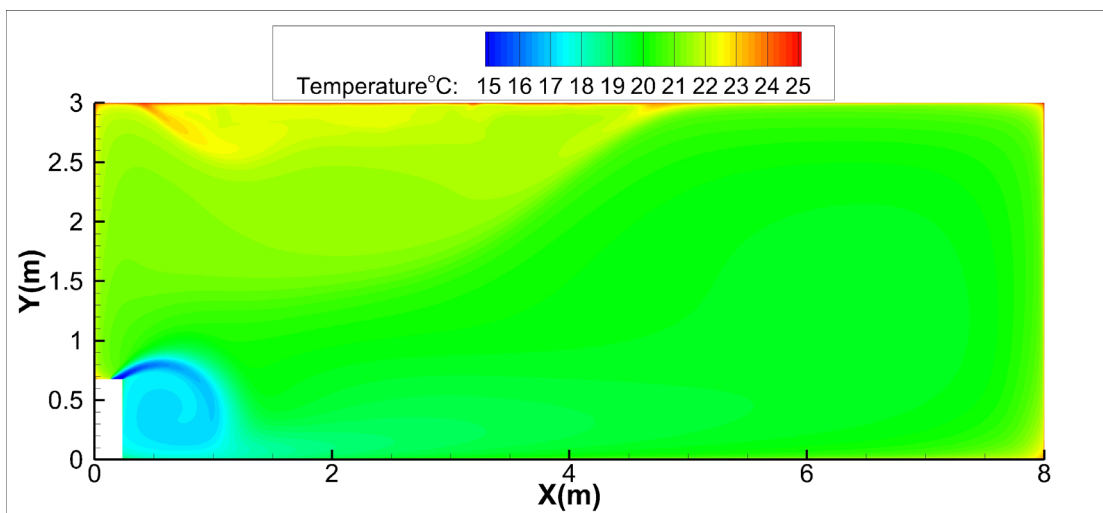

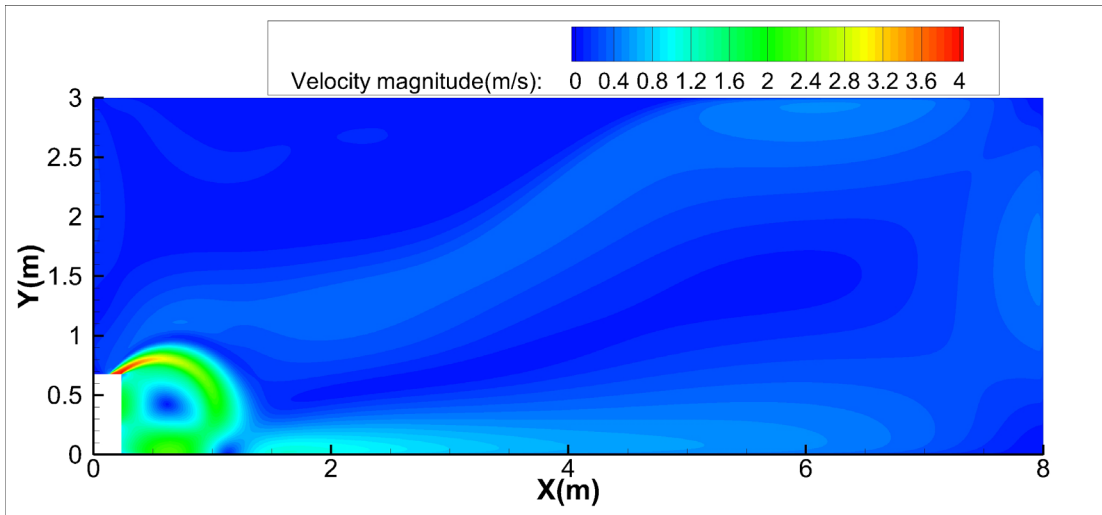

Discharge Angle 60°

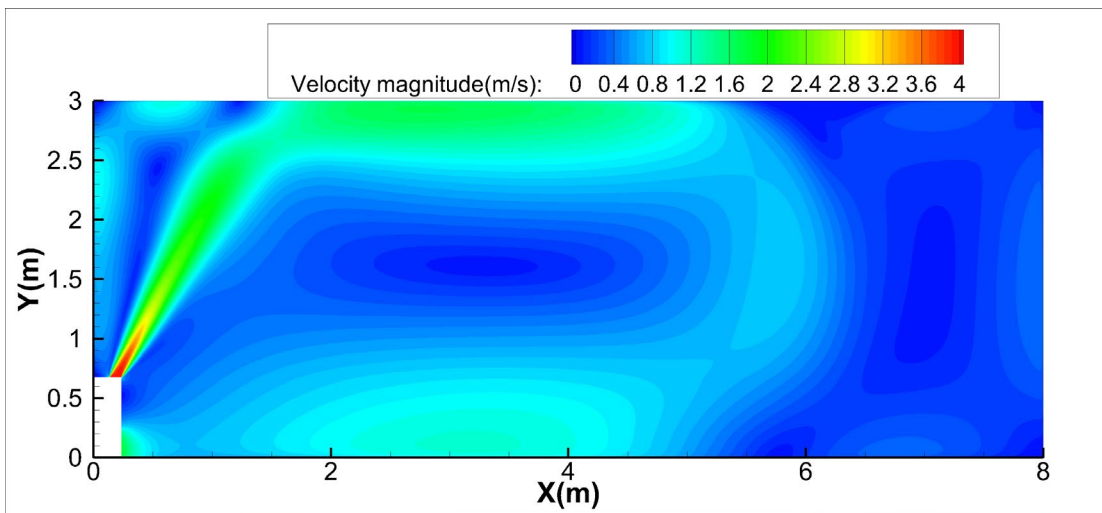
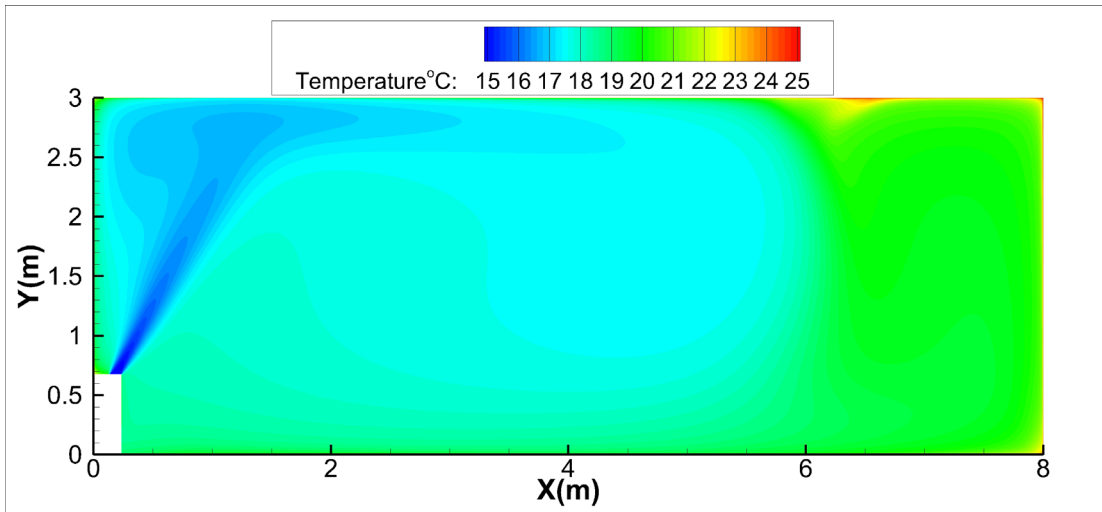

Heating

Ceiling installation:

Discharge Angle 30°

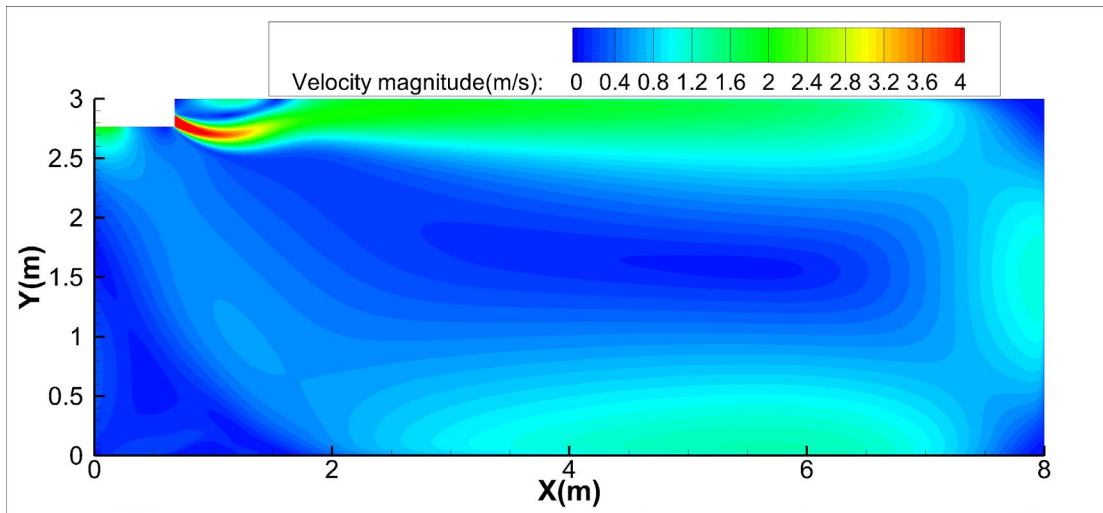
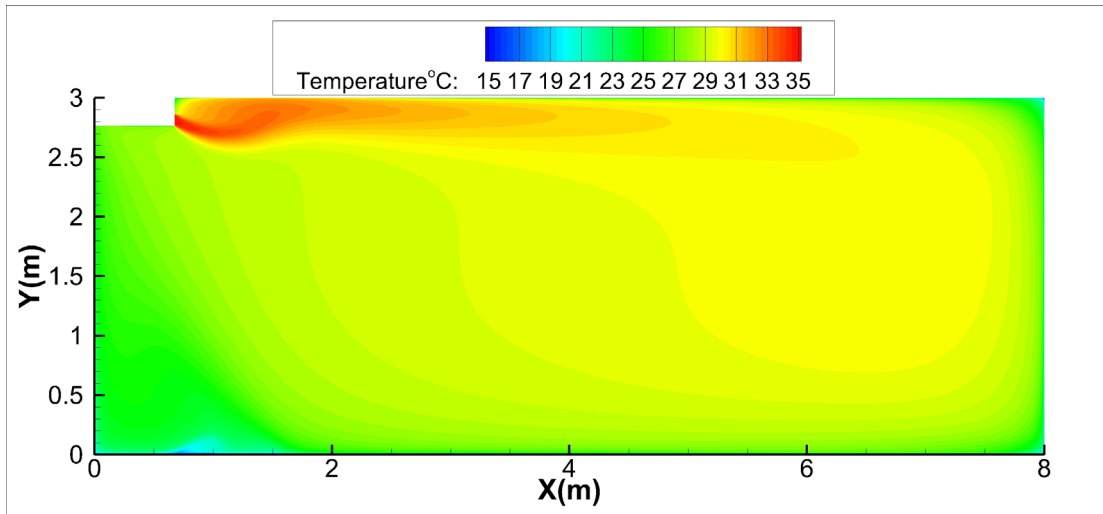

Discharge Angle 60°

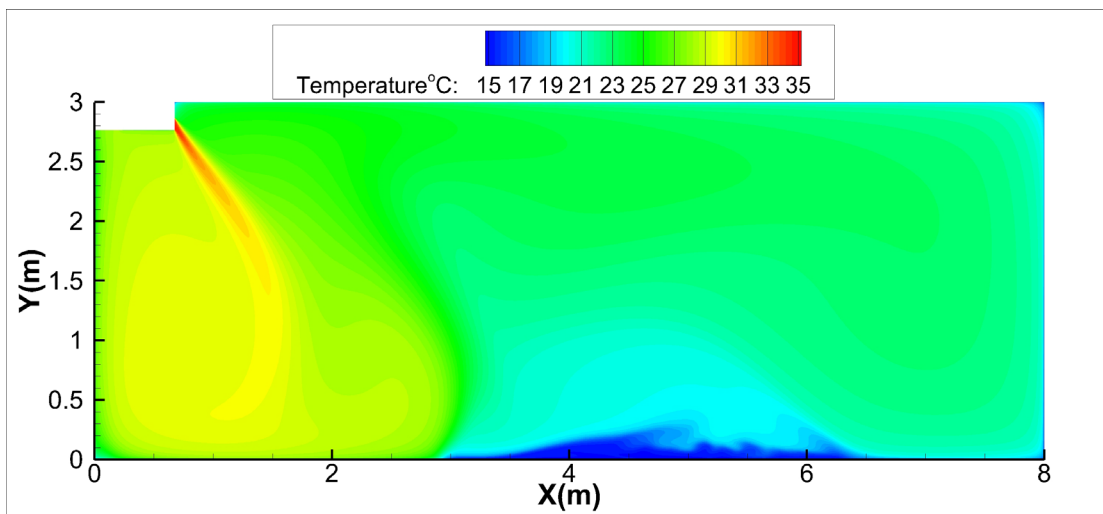

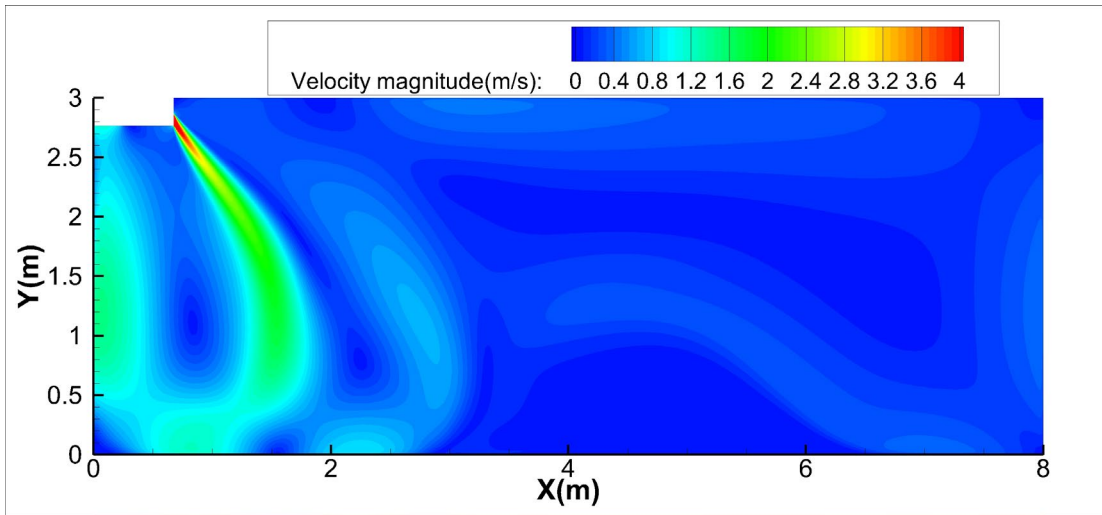

Floor installation:
Discharge Angle 30°

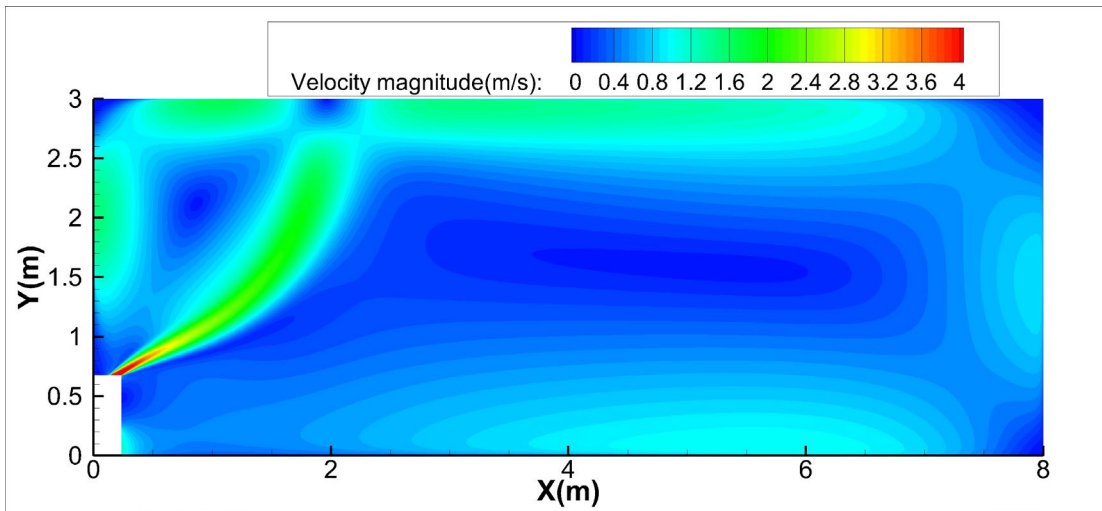
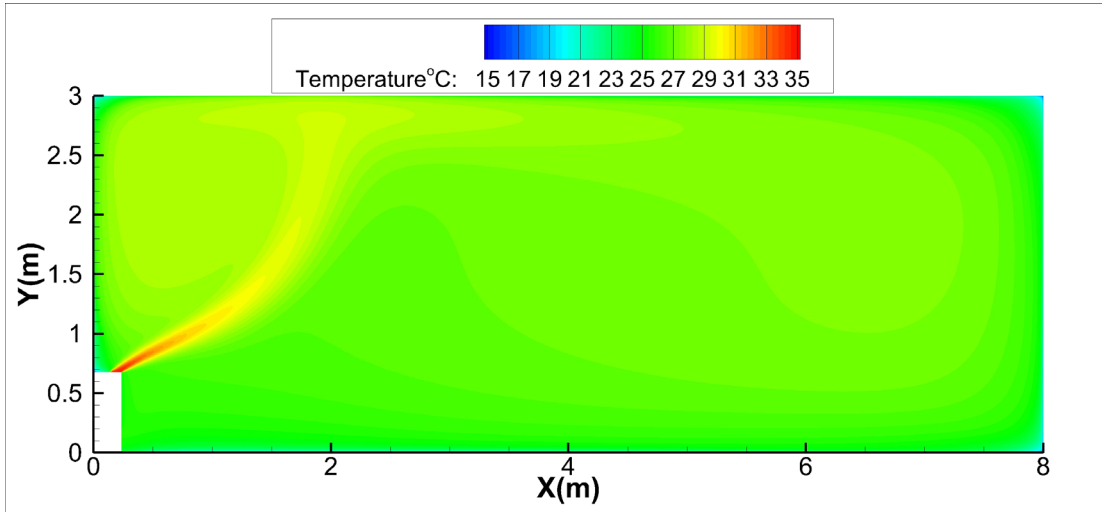

Discharge Angle 60°

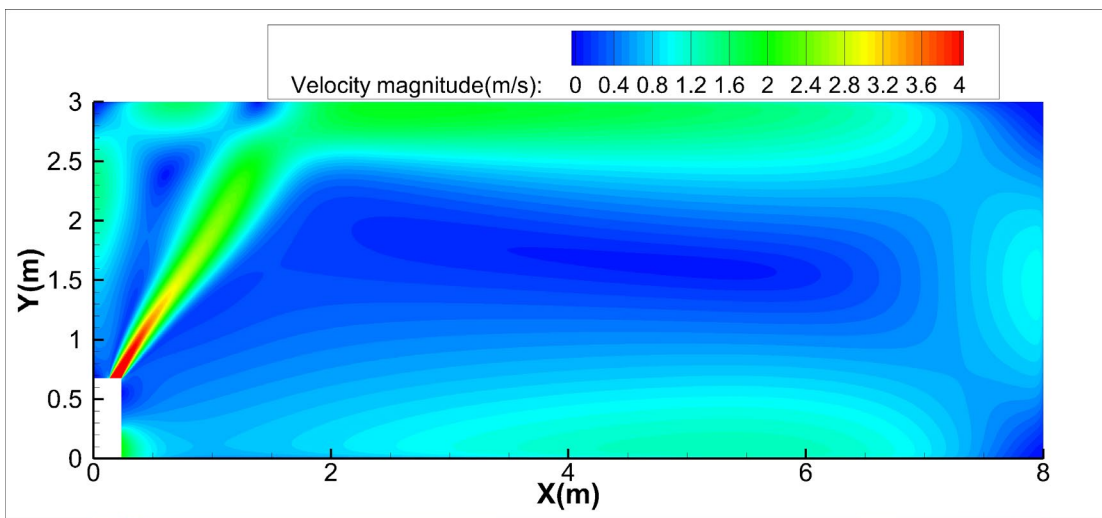
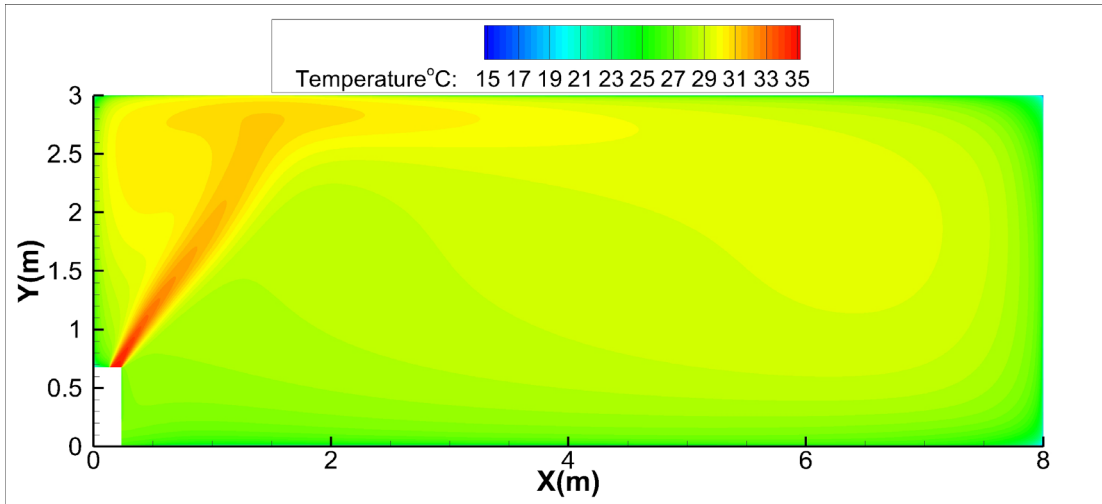

36K

Cooling

Ceiling installation:

Discharge Angle 30°

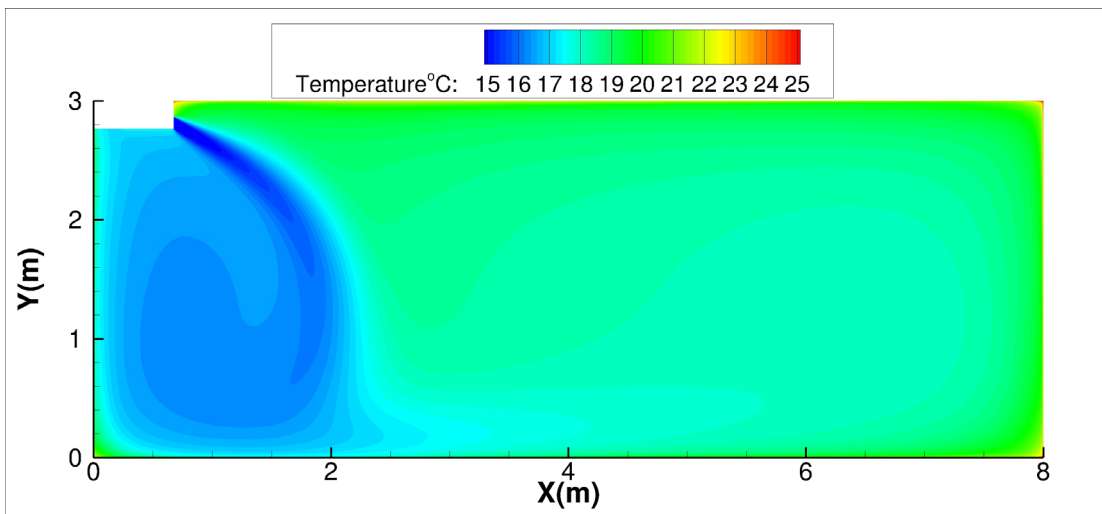

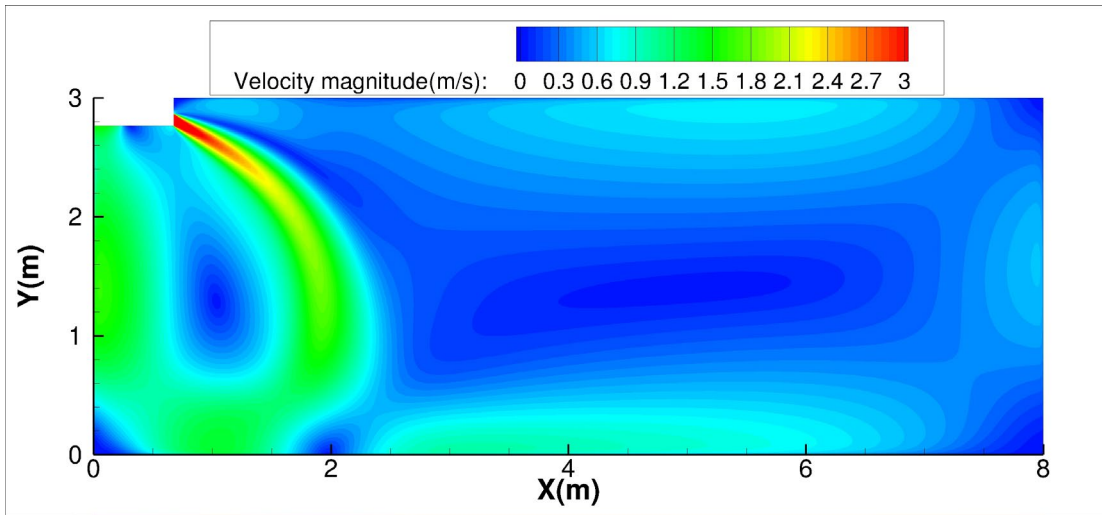

Discharge Angle 60°

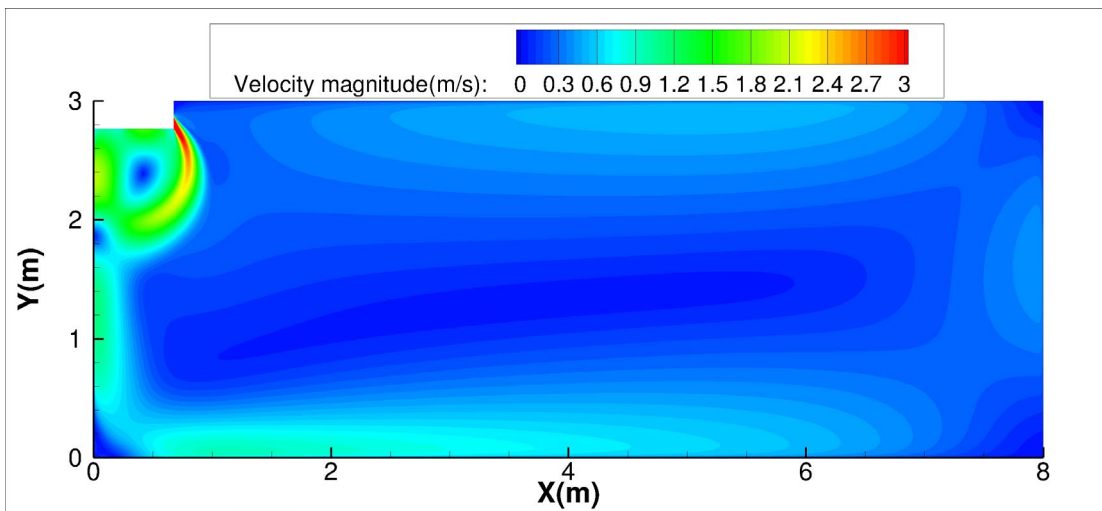
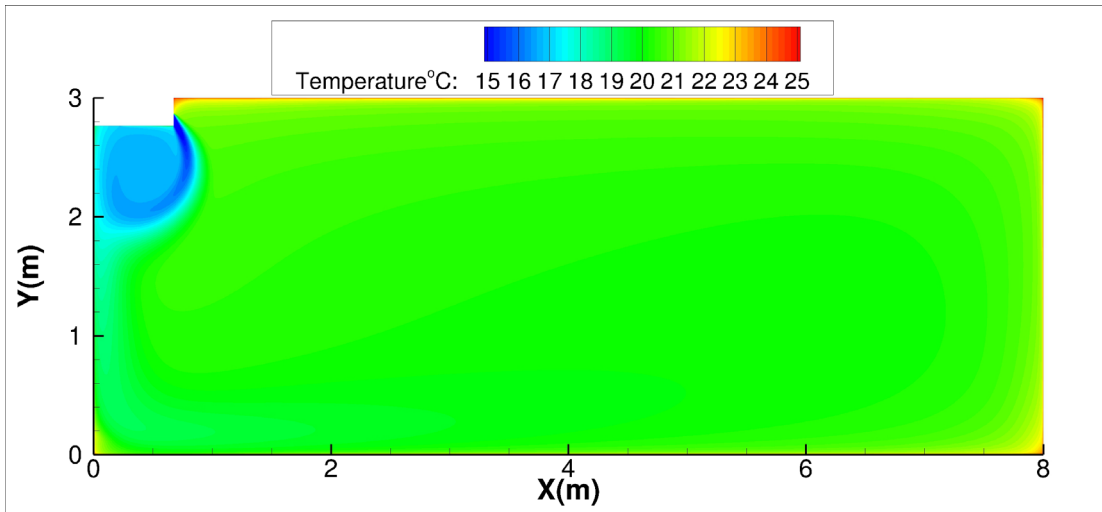

Floor installation:
Discharge Angle 30°

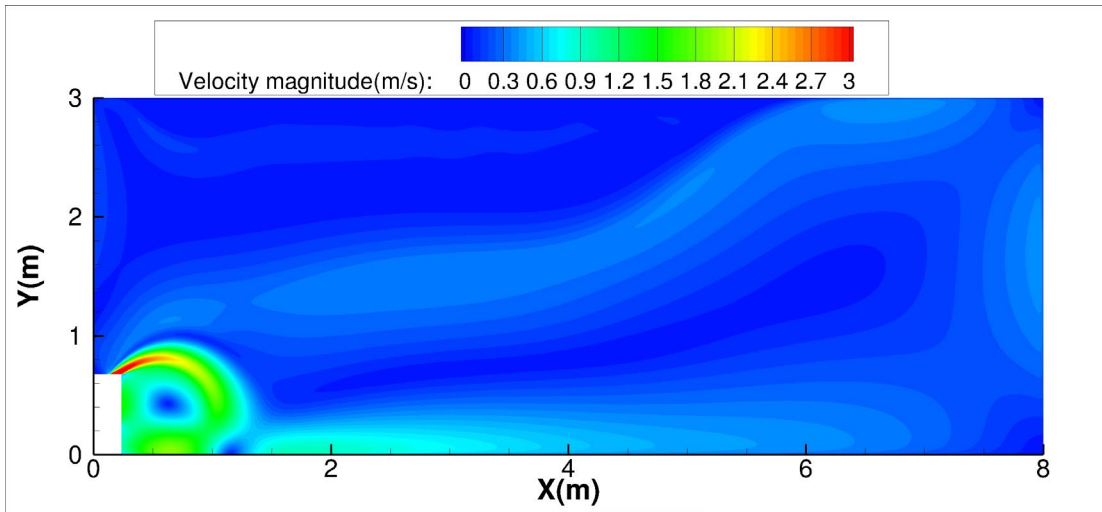
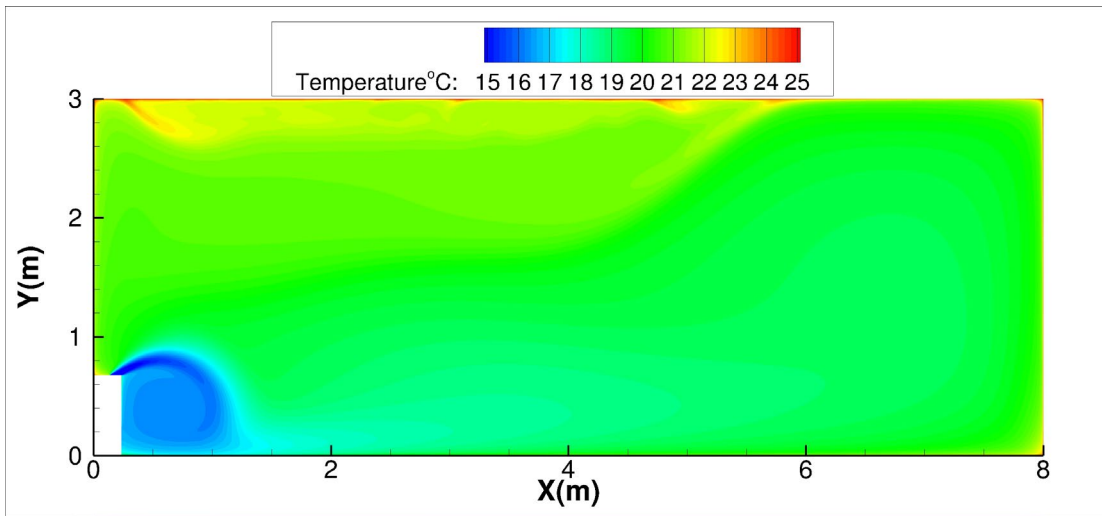

Discharge Angle 60°

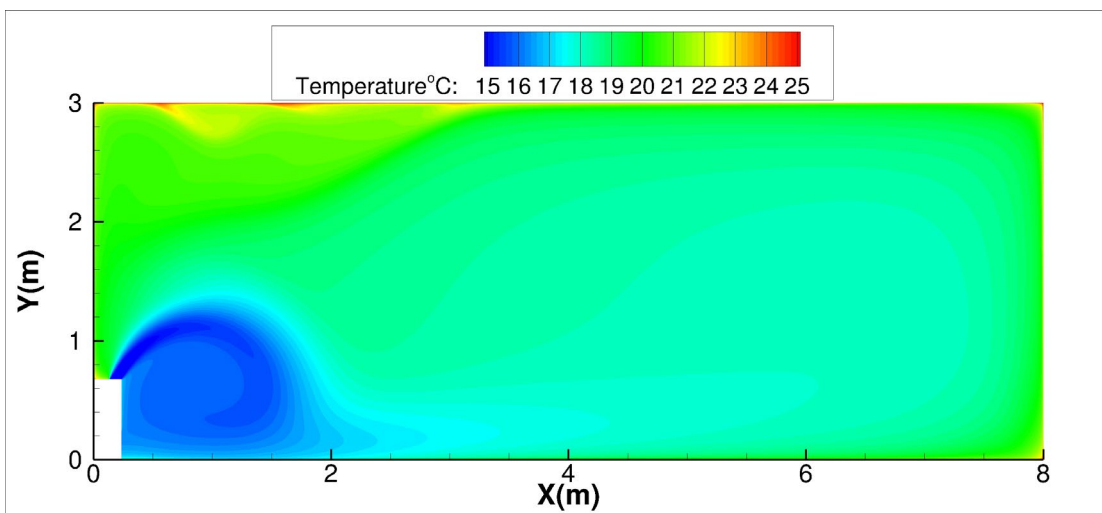

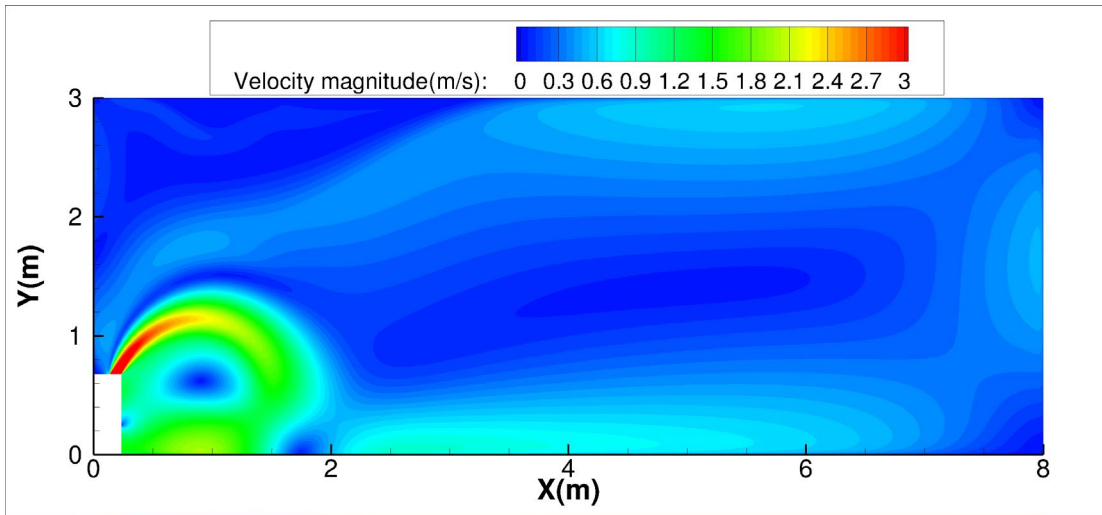

Heating
 Ceiling installation:
 Discharge Angle 30°

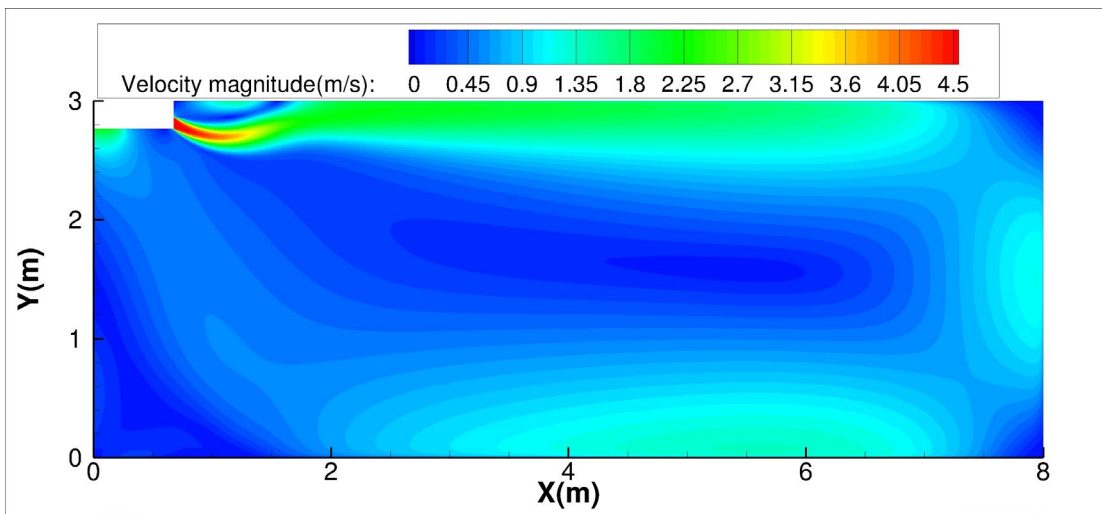
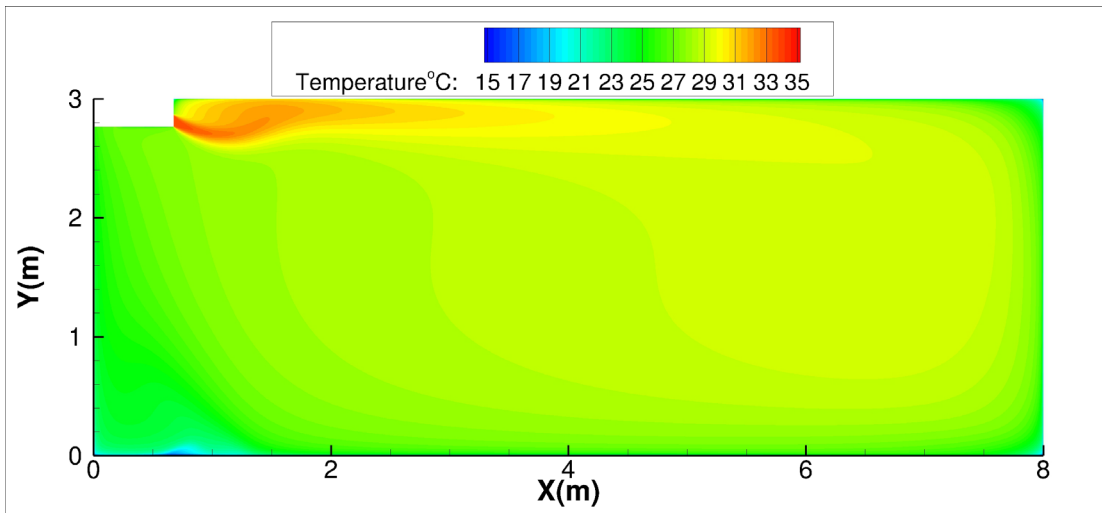

Discharge Angle 60°

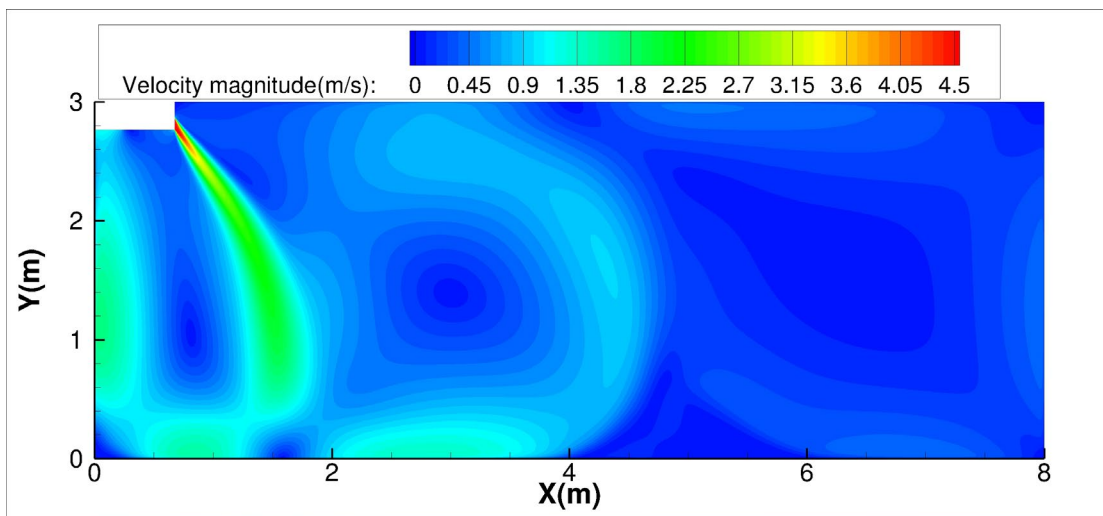
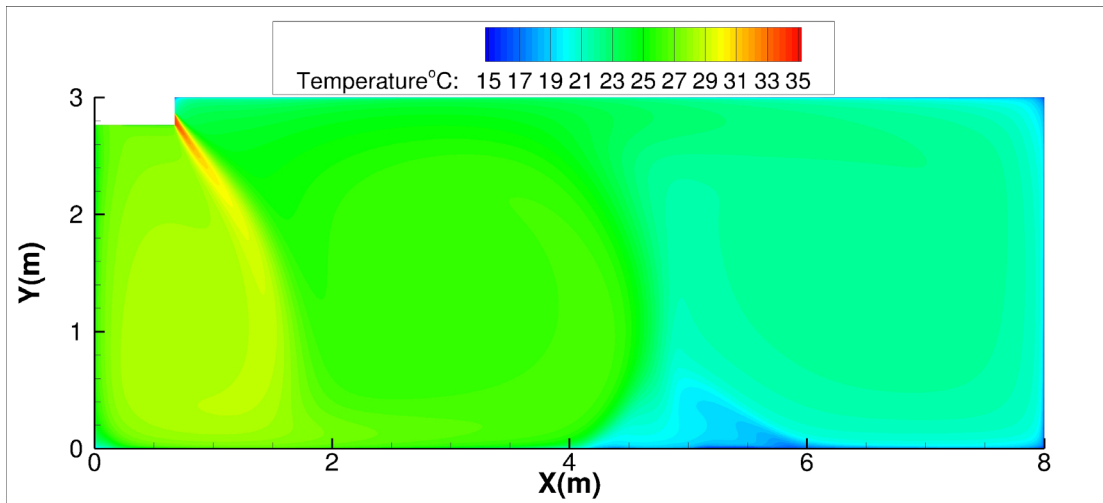

Floor installation:
Discharge Angle 30°

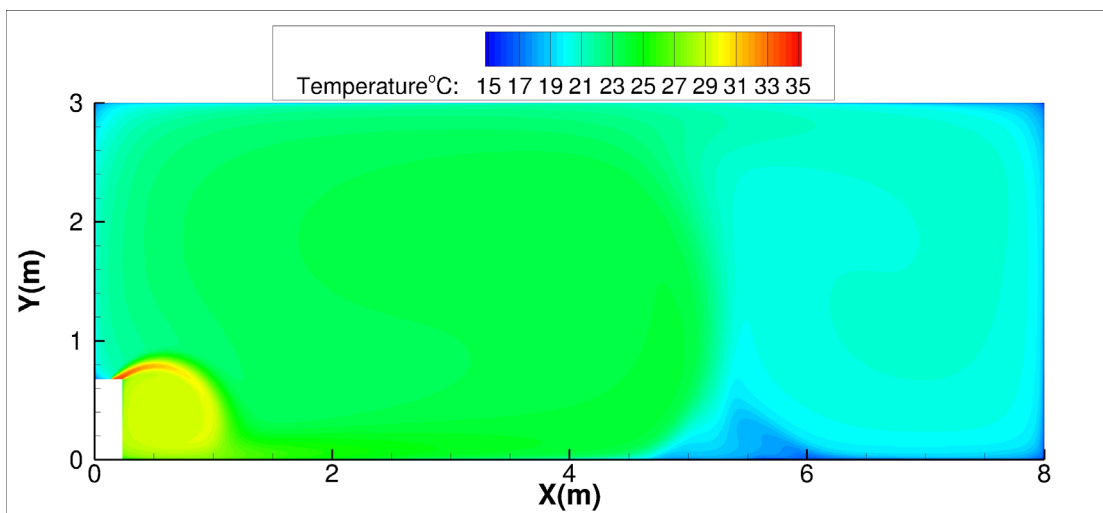

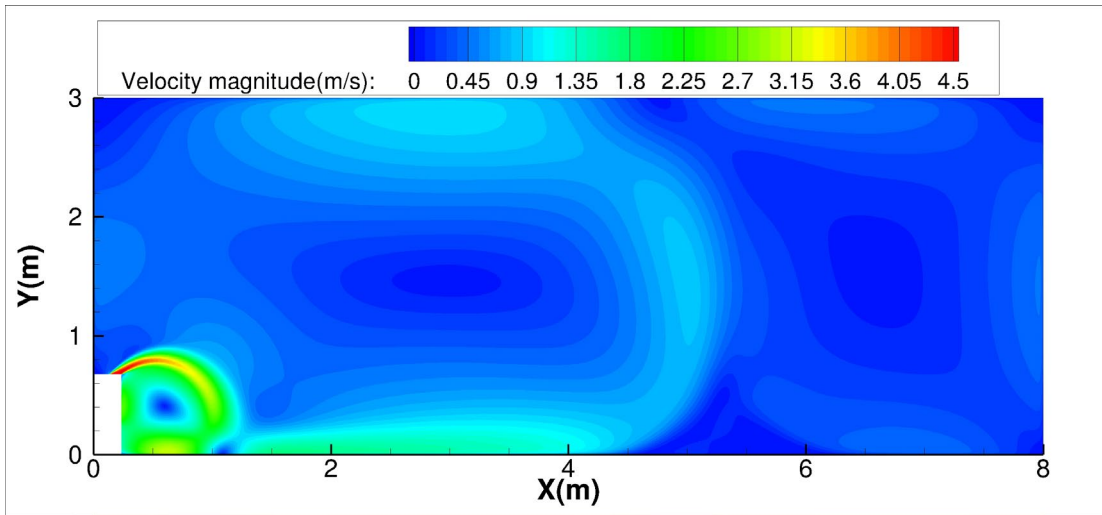

Discharge Angle 60°

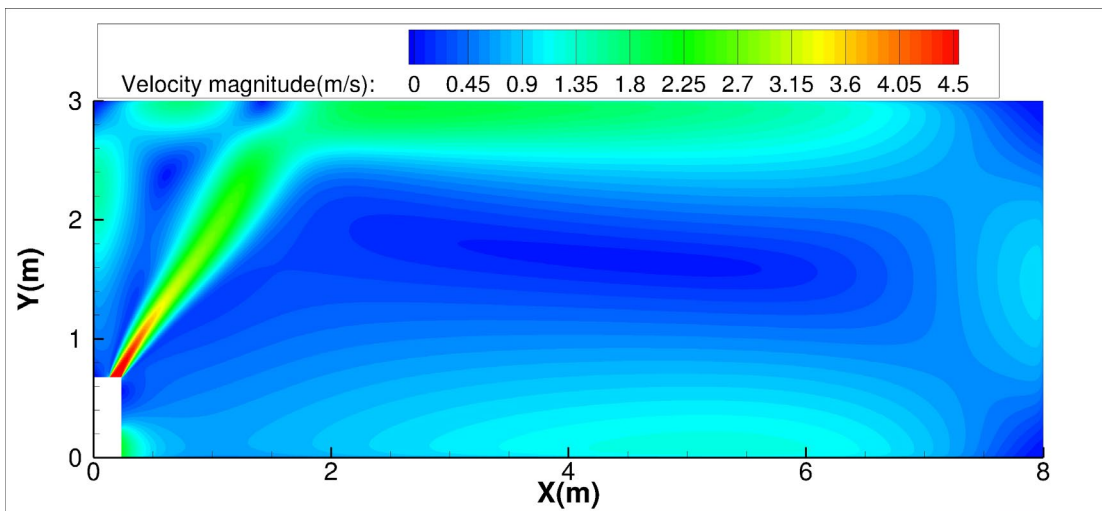
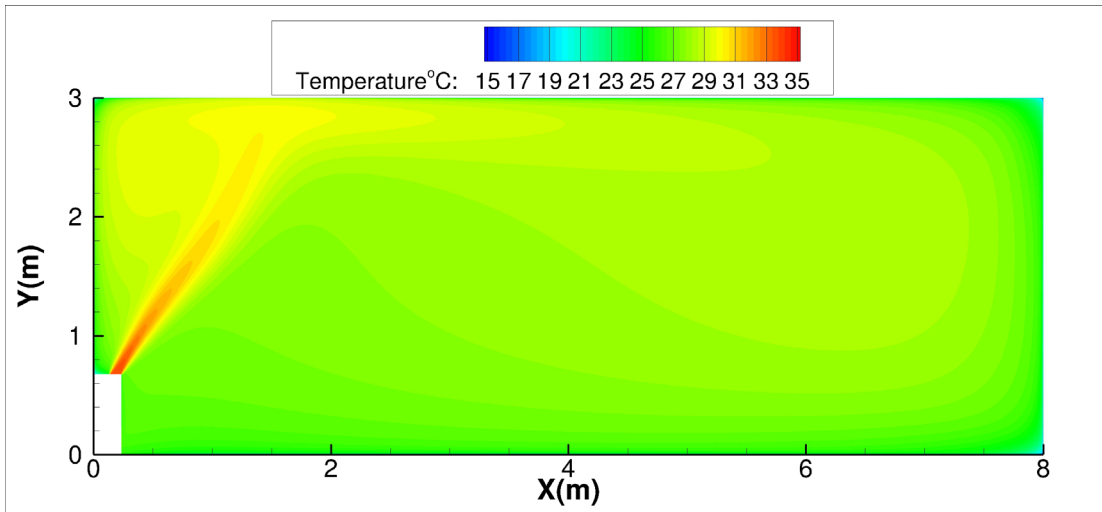

48K
Cooling
Ceiling installation:
Discharge Angle 30°

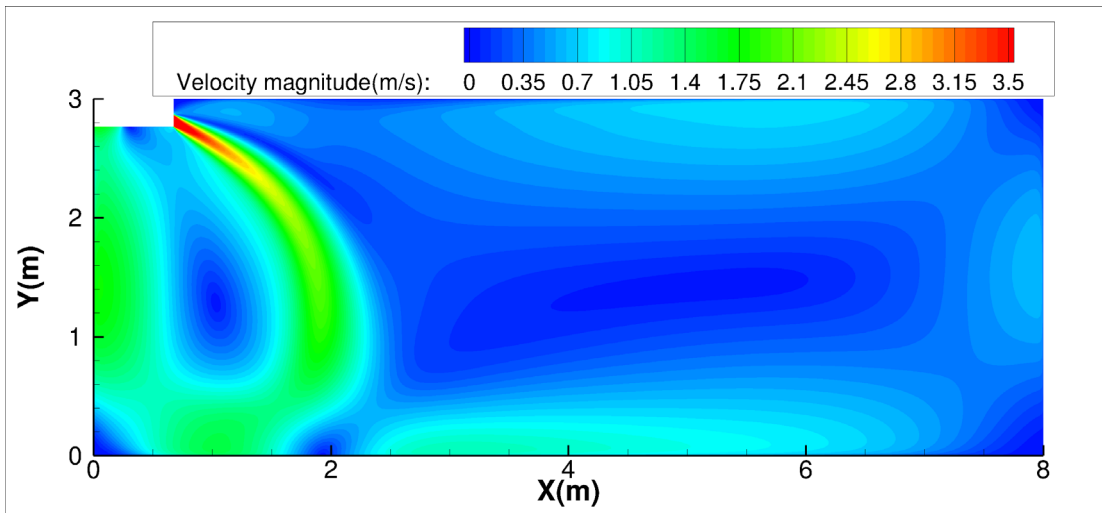
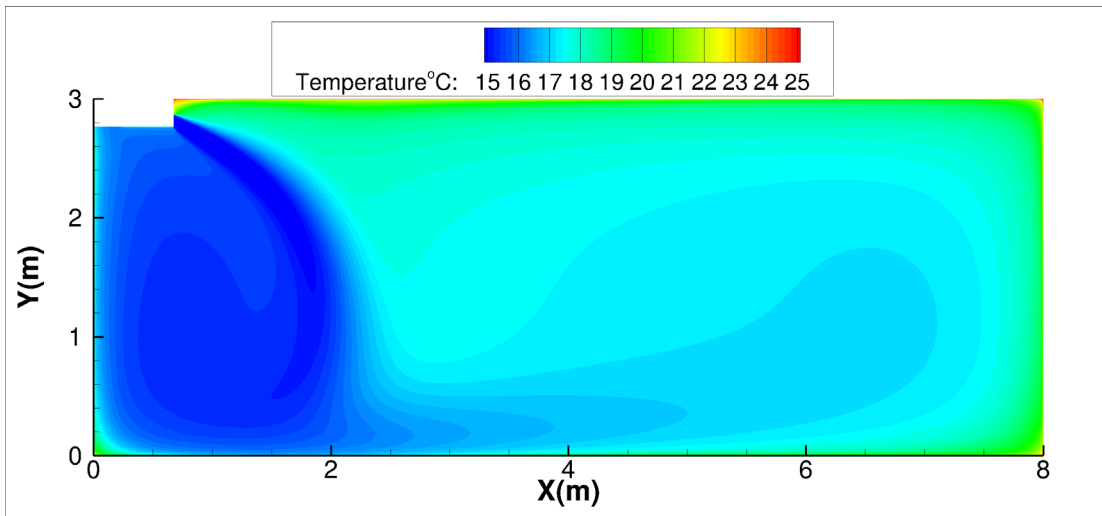

Discharge Angle 60°

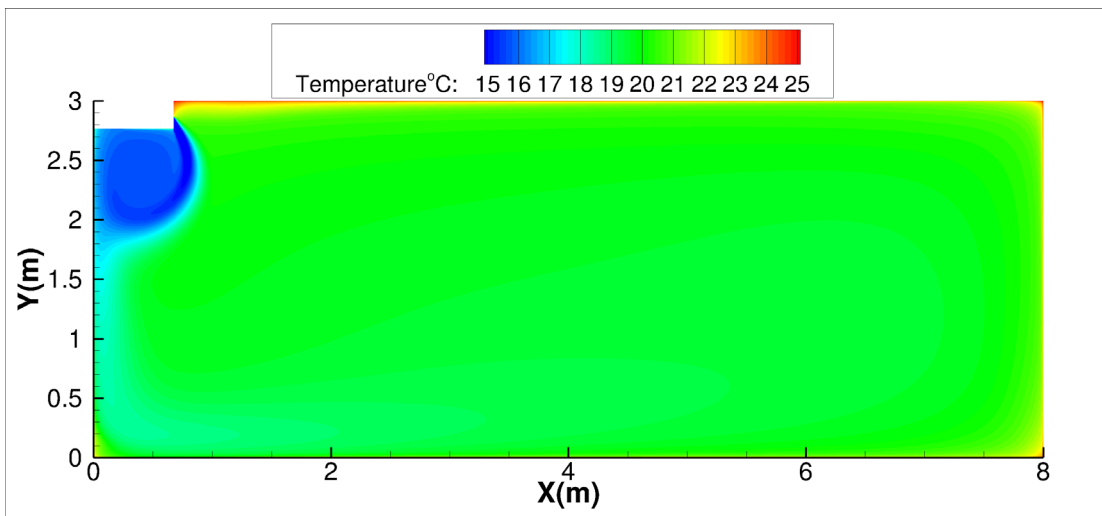

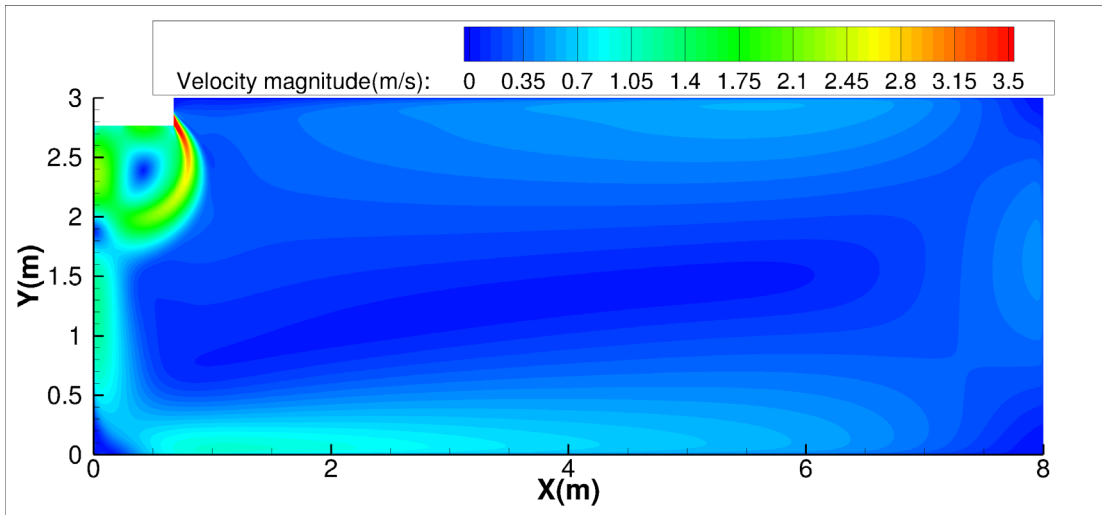

Floor installation:
Discharge Angle 30°

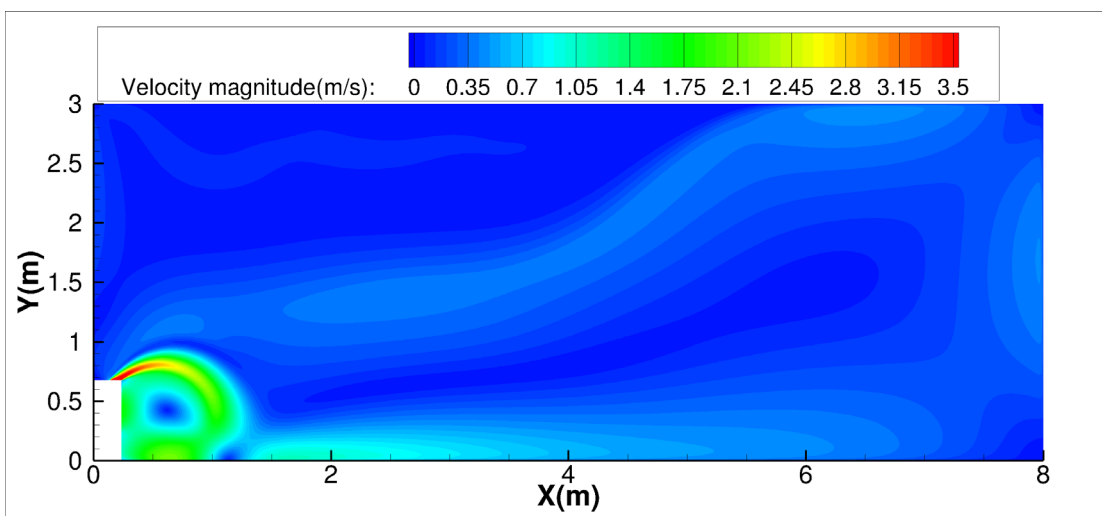
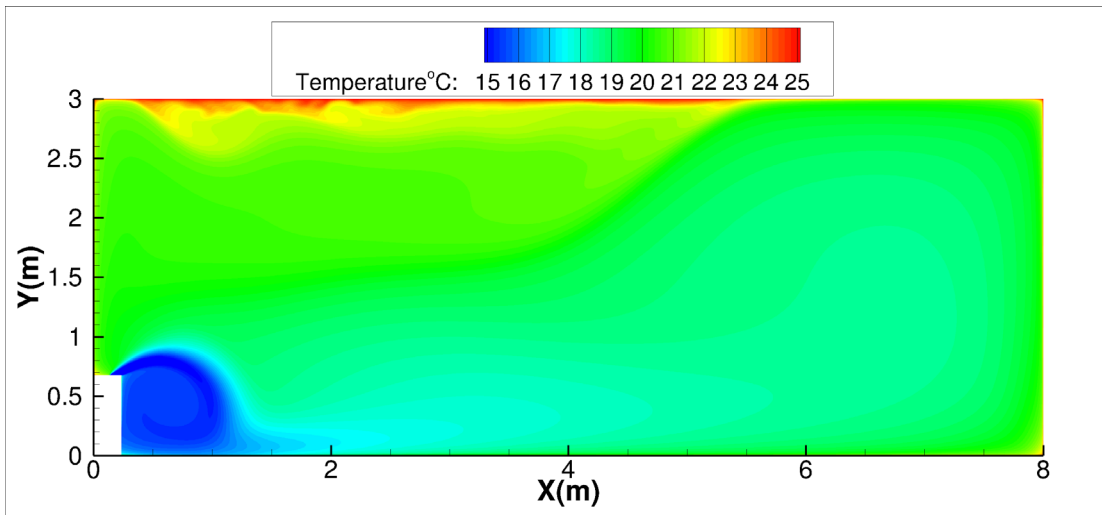

Discharge Angle 60°

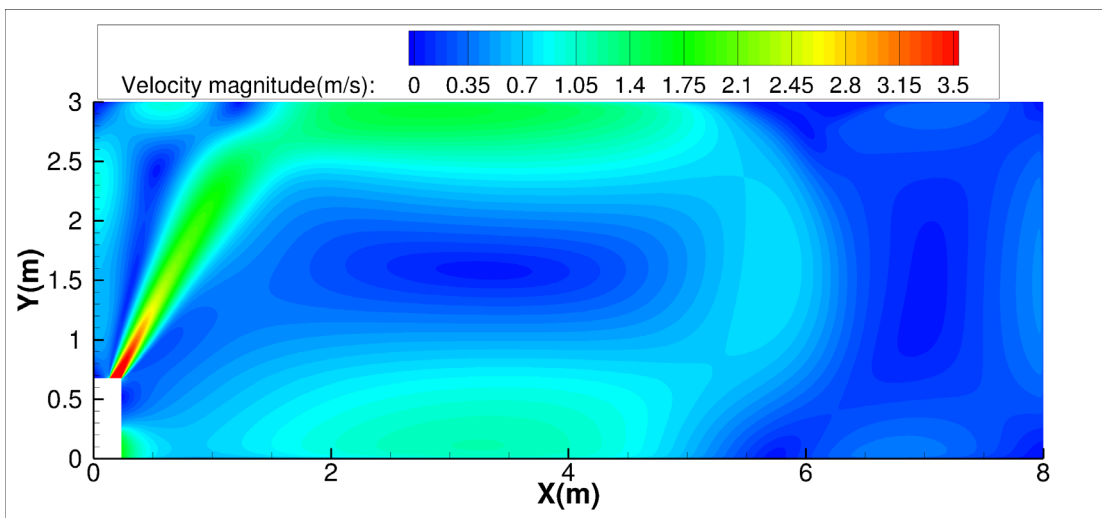
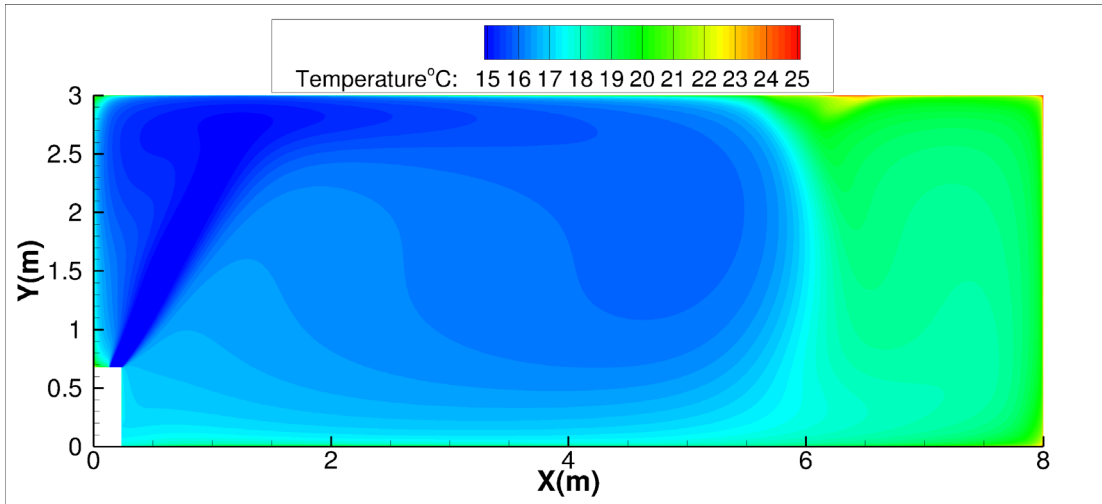

Heating

Ceiling installation:

Discharge Angle 30°

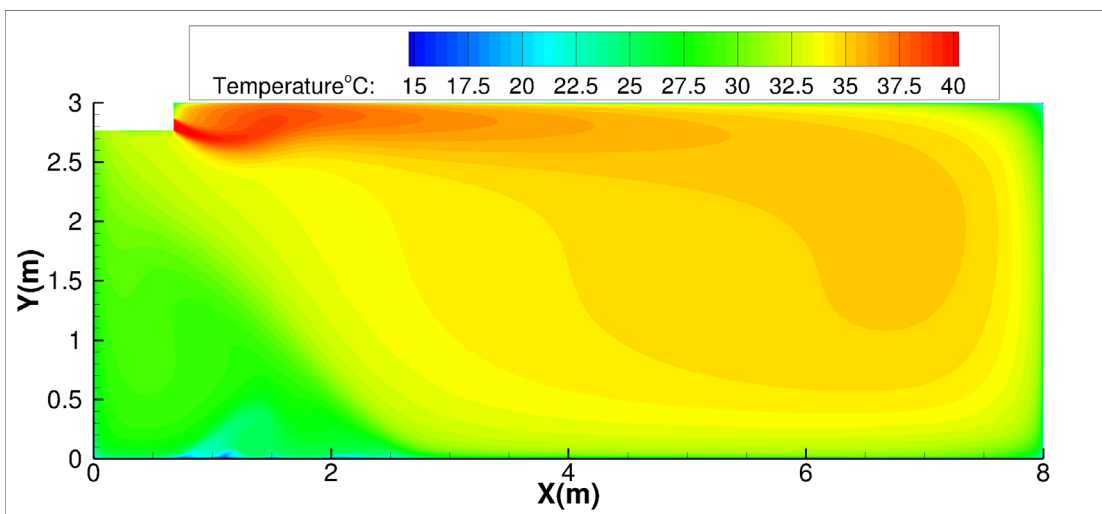

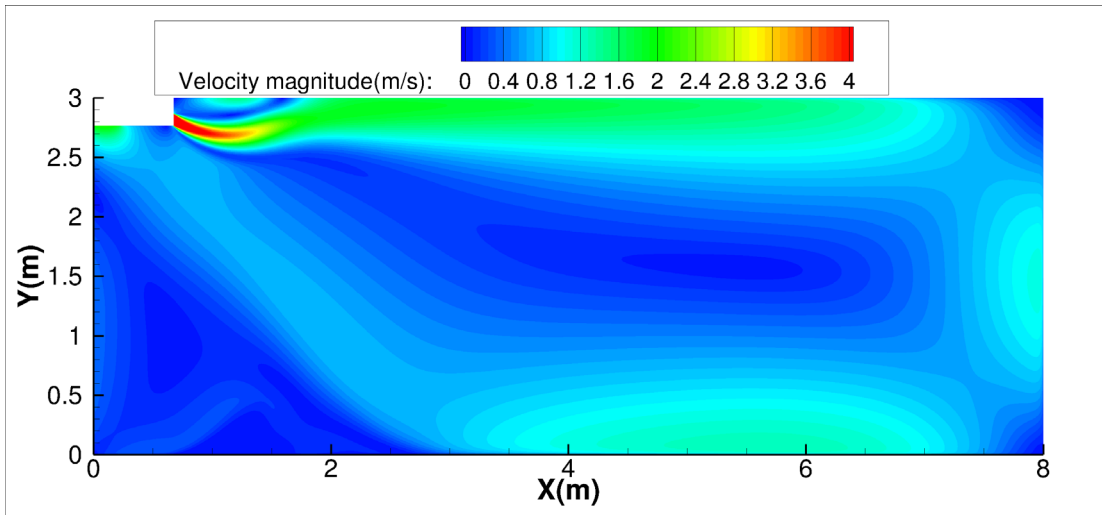

Discharge Angle 60°

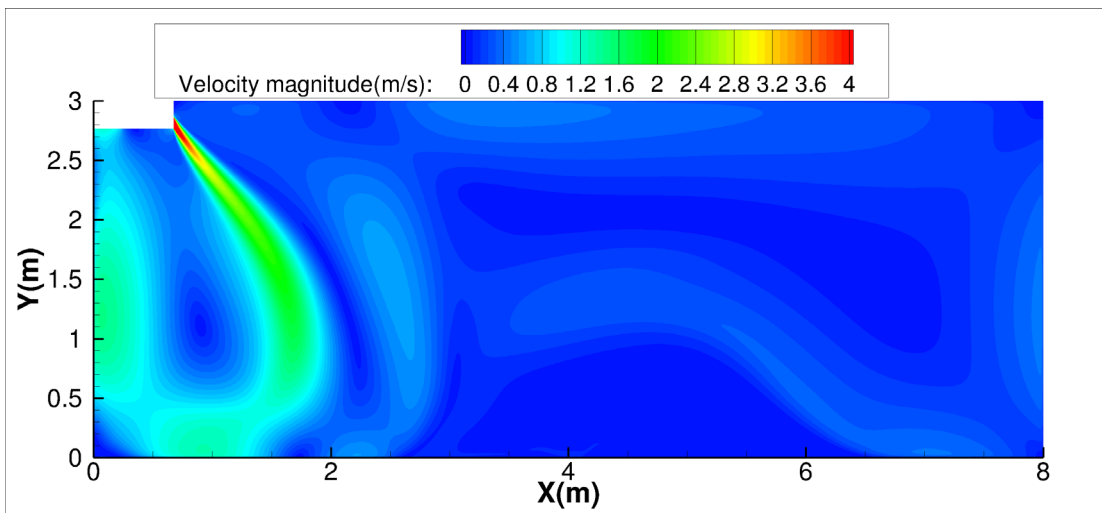
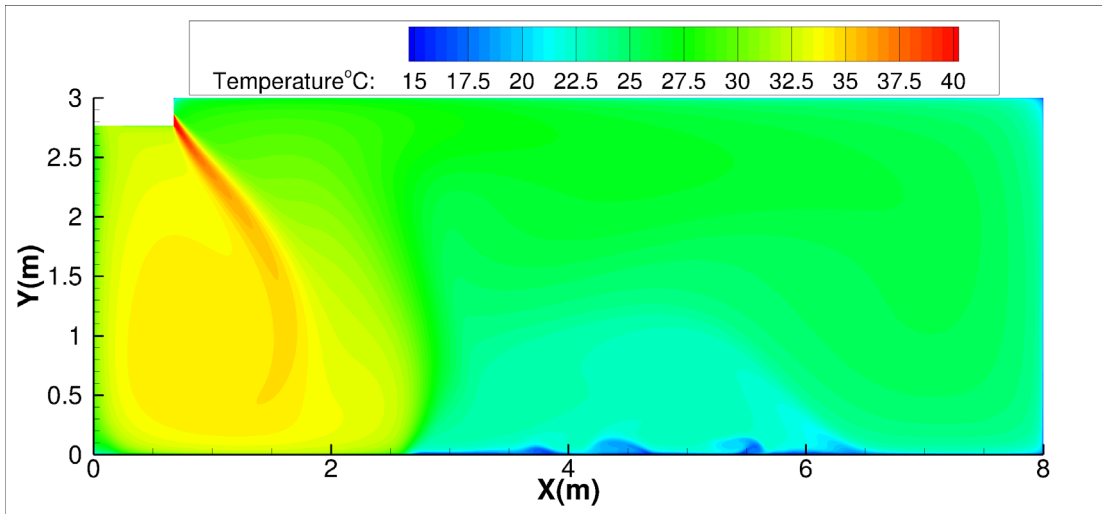

Floor installation:
Discharge Angle 30°

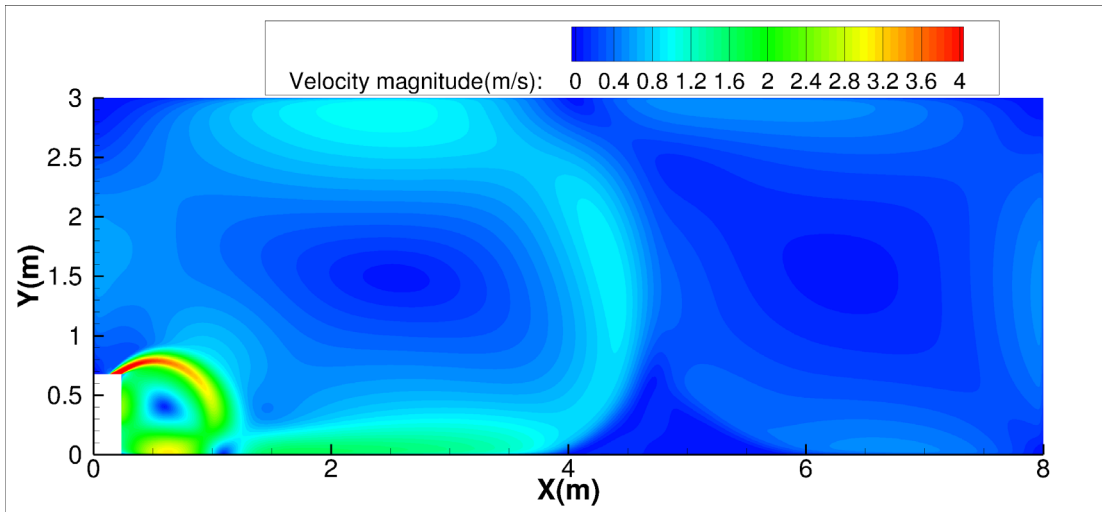
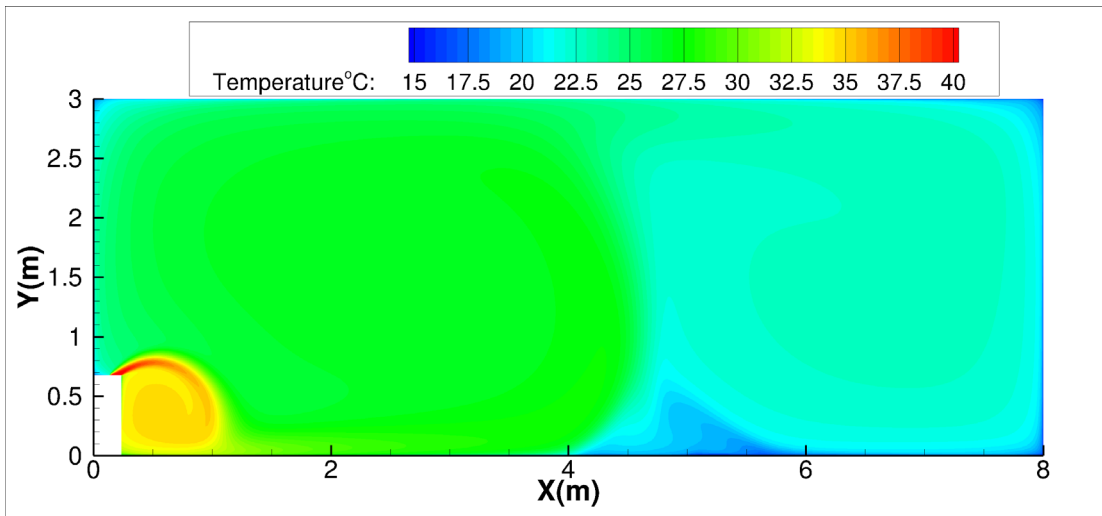

Discharge Angle 60°

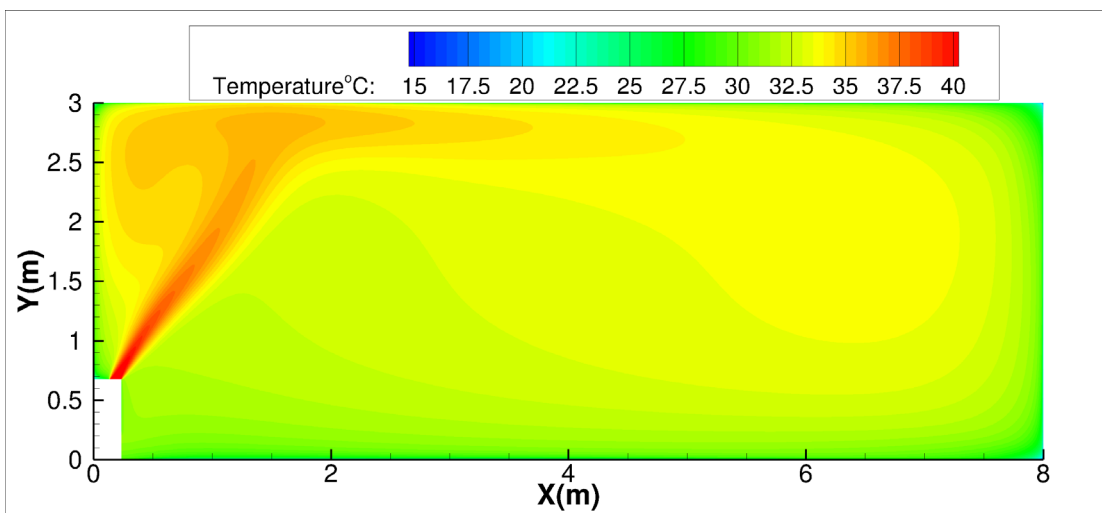

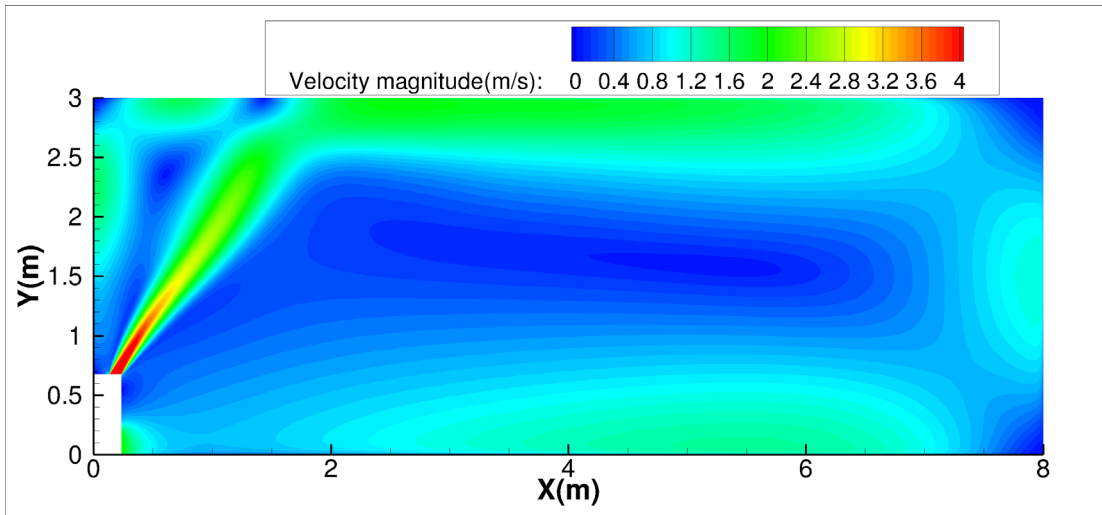

60K
 Cooling
 Ceiling installation:
 Discharge Angle 30°

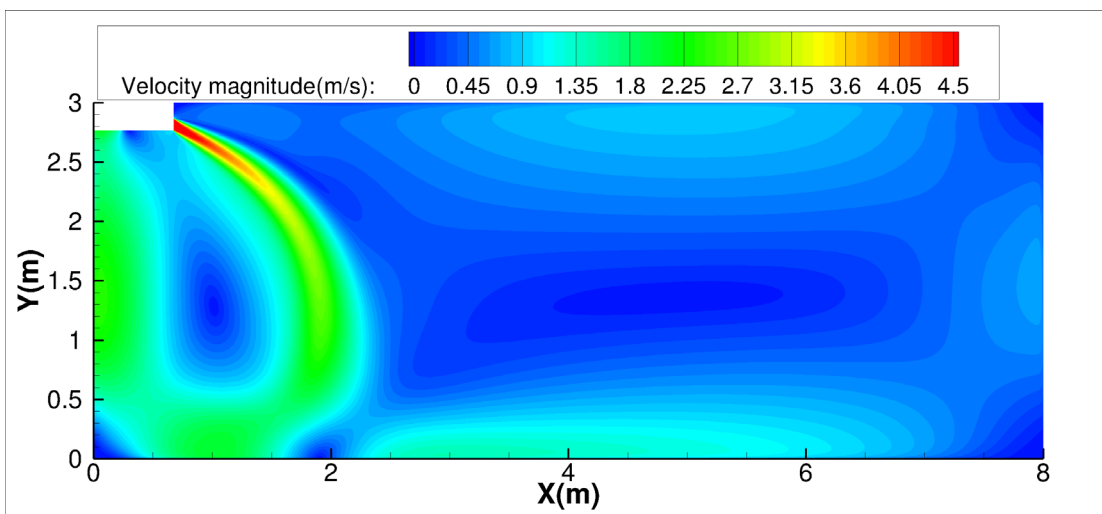
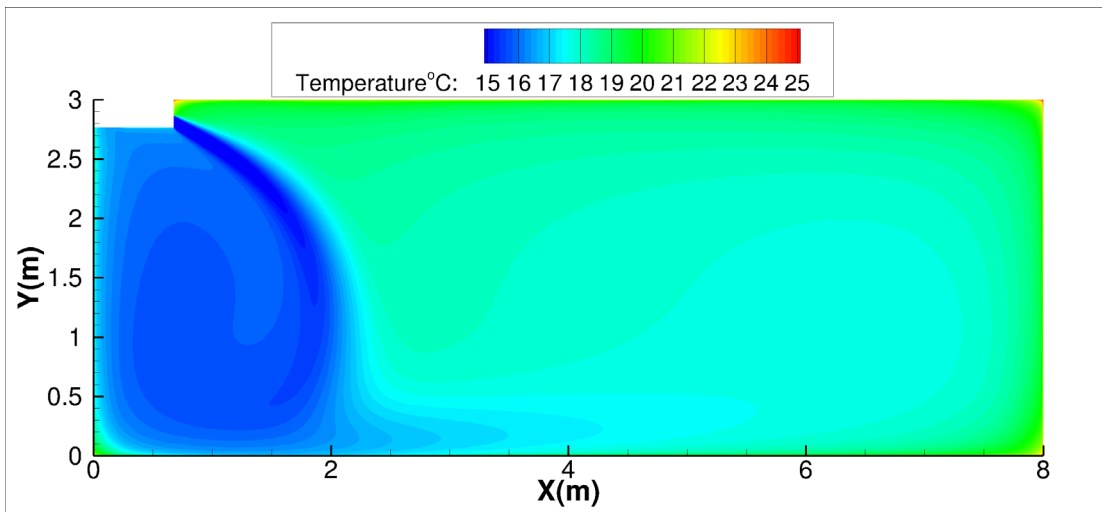

Discharge Angle 60°

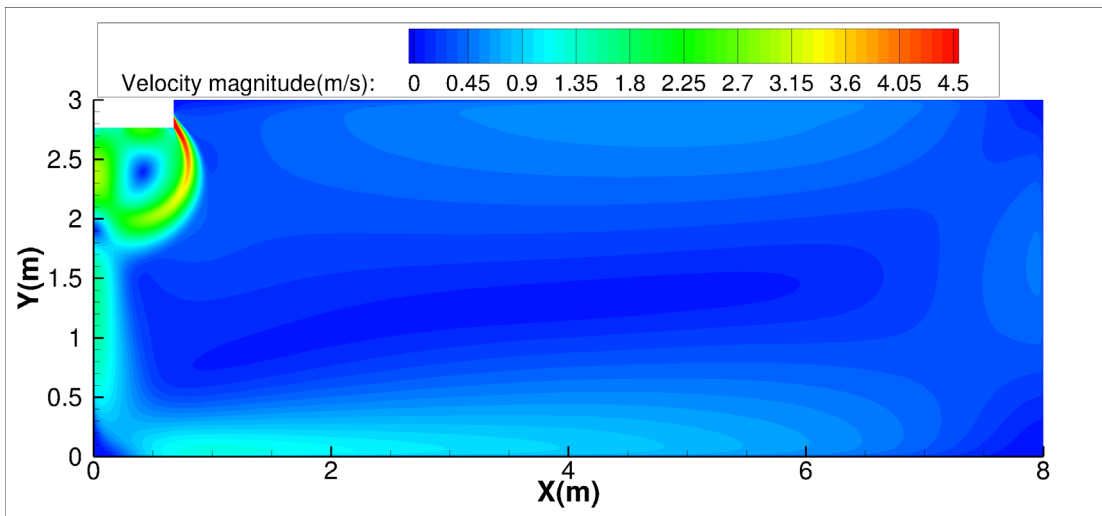
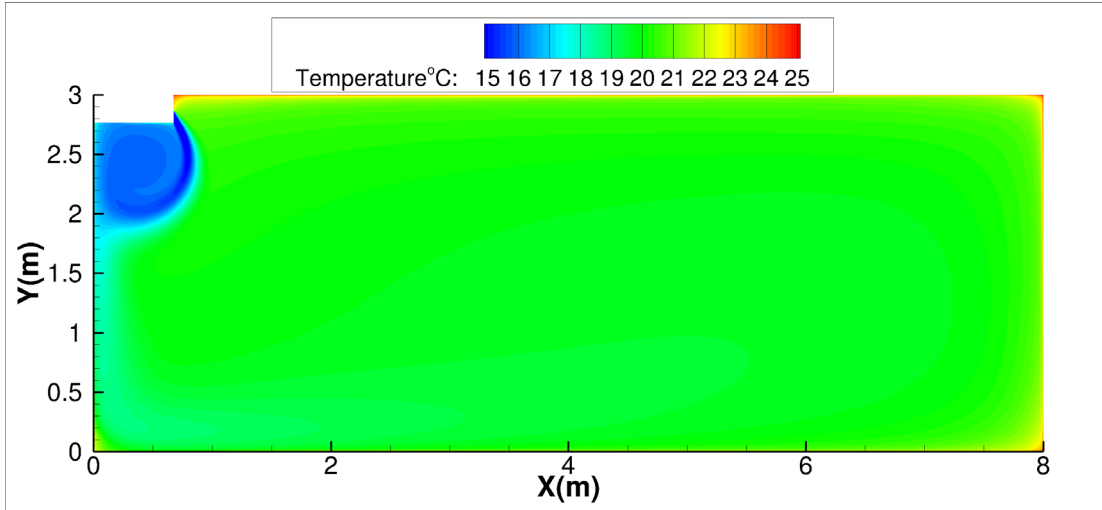

Floor installation:
Discharge Angle 30°

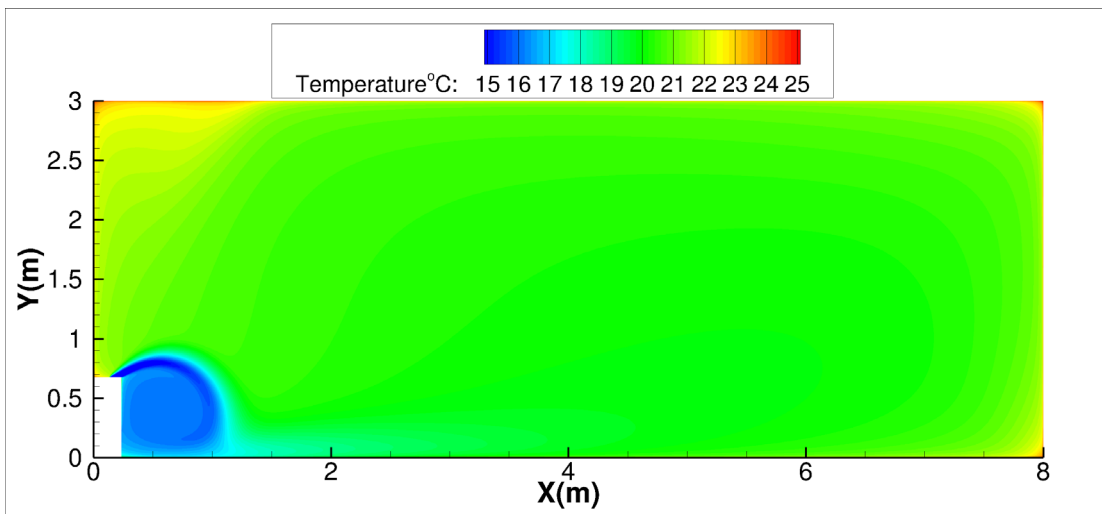

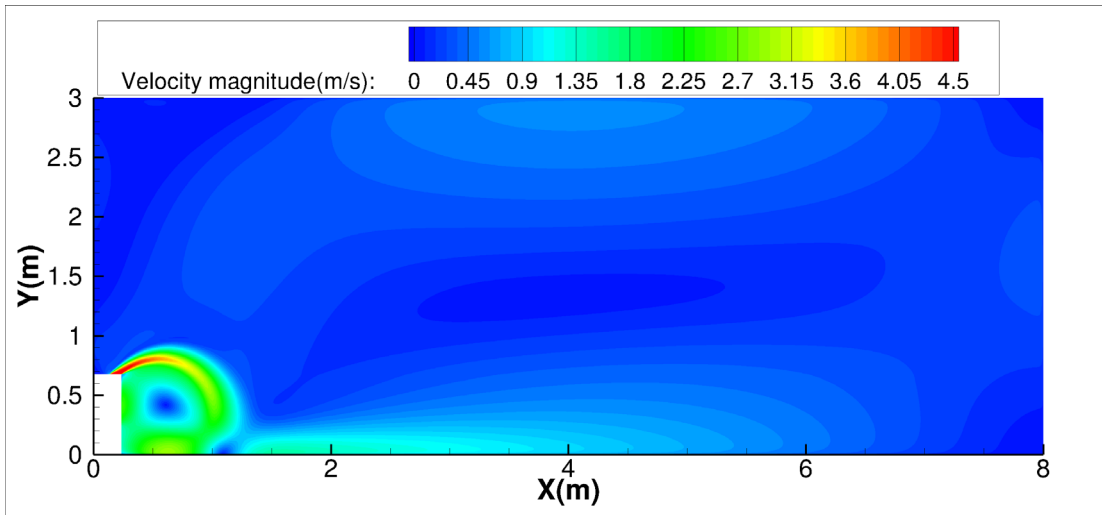

Discharge Angle 60°

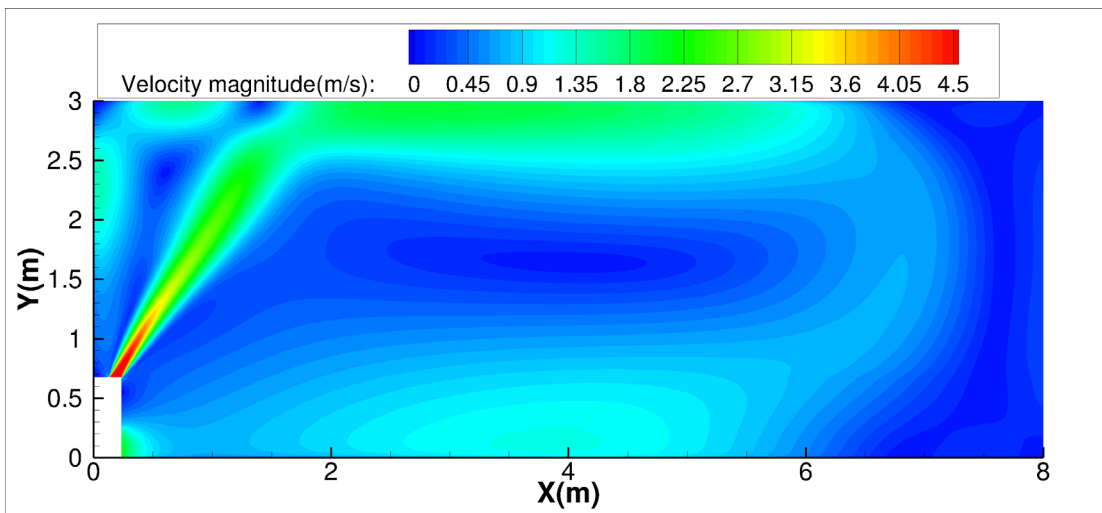
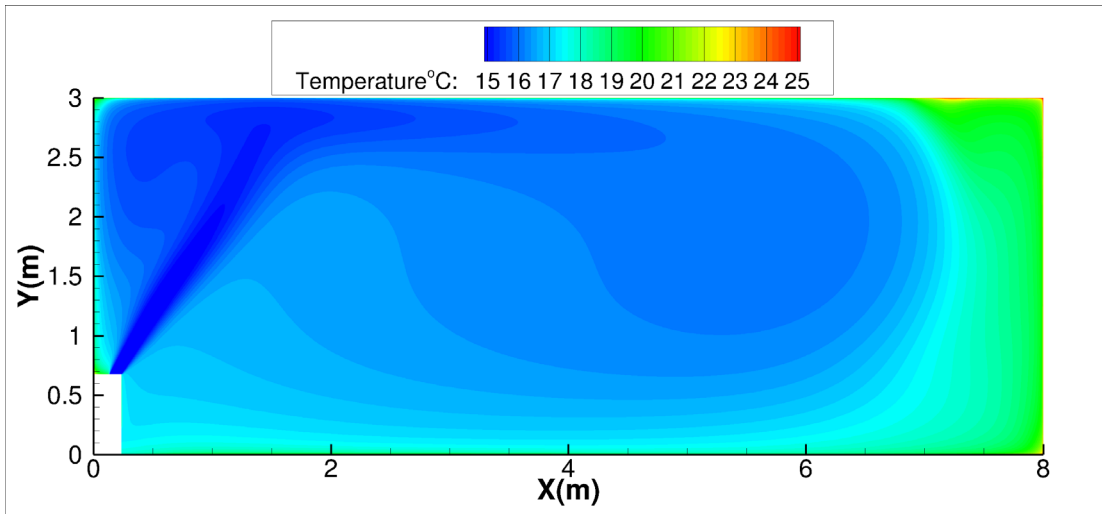

Heating

Ceiling installation:

Discharge Angle 30°

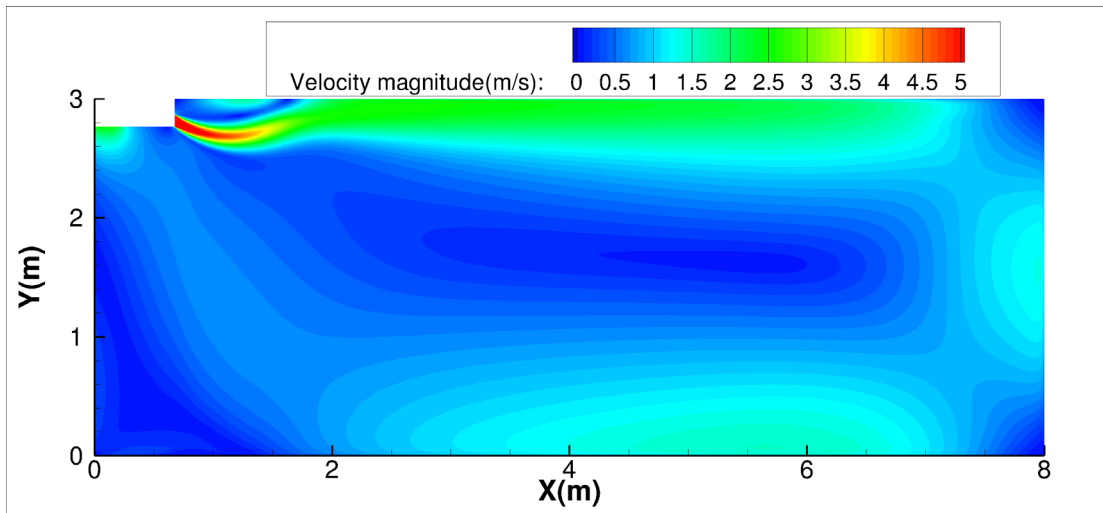
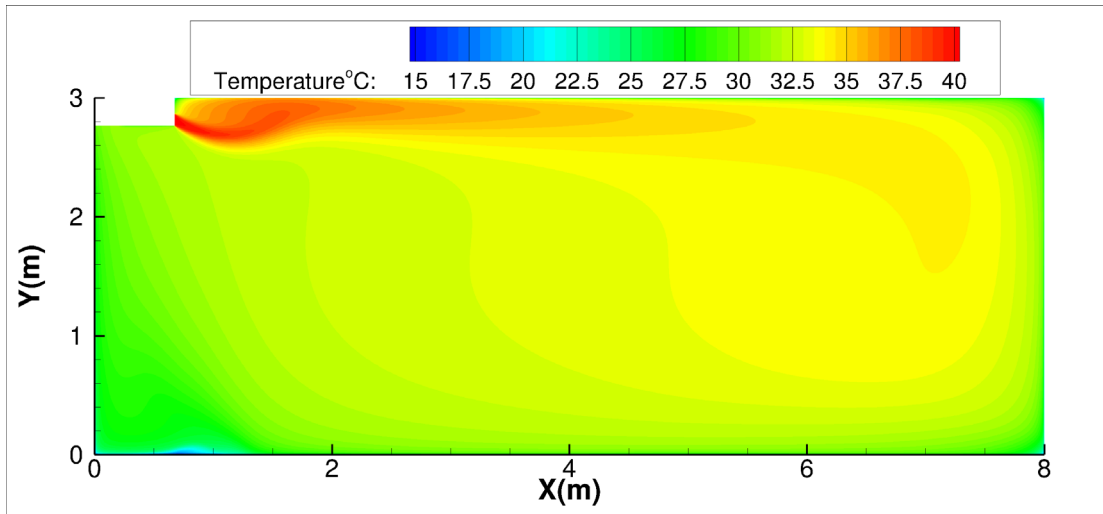

Discharge Angle 60°

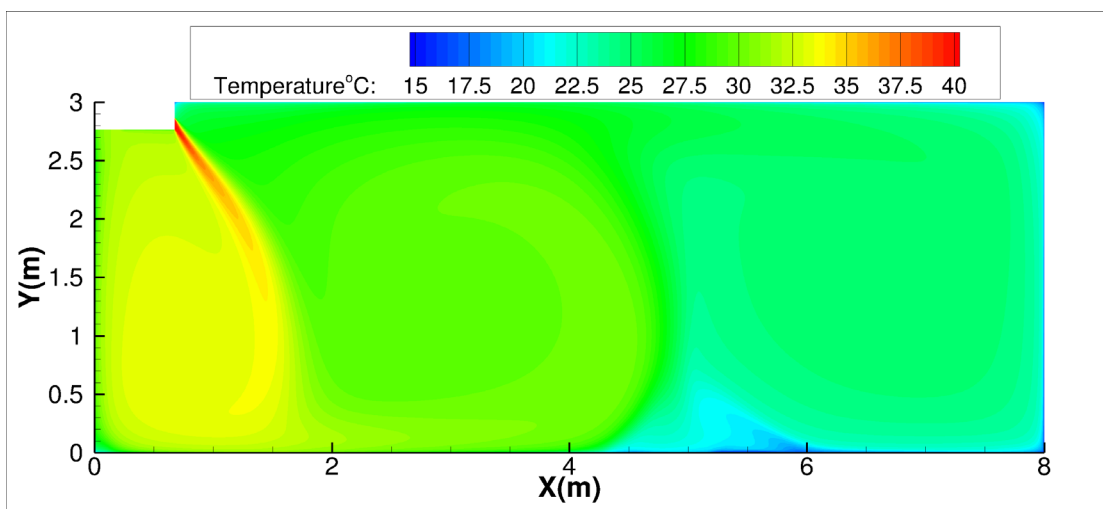

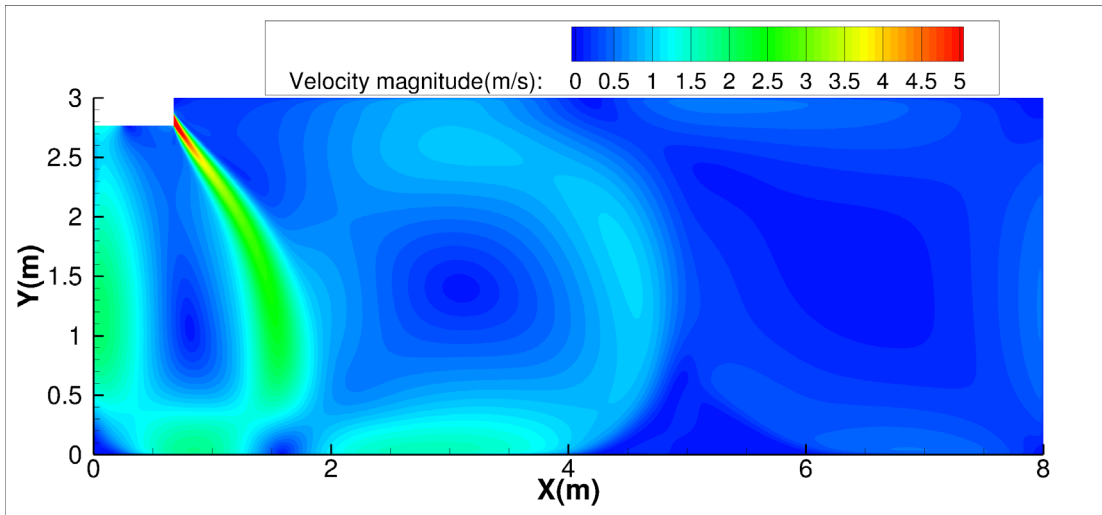

Floor installation:
Discharge Angle 30°

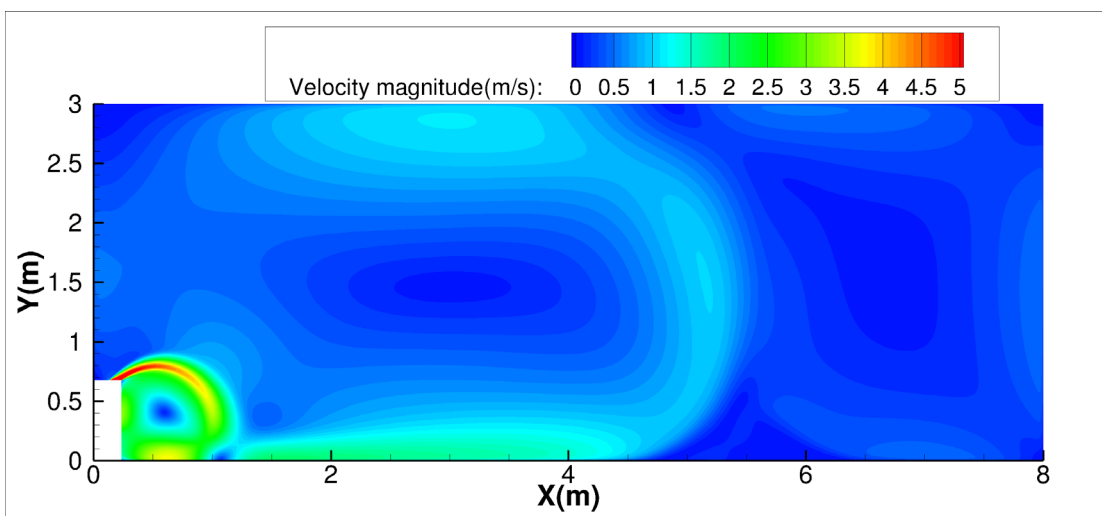
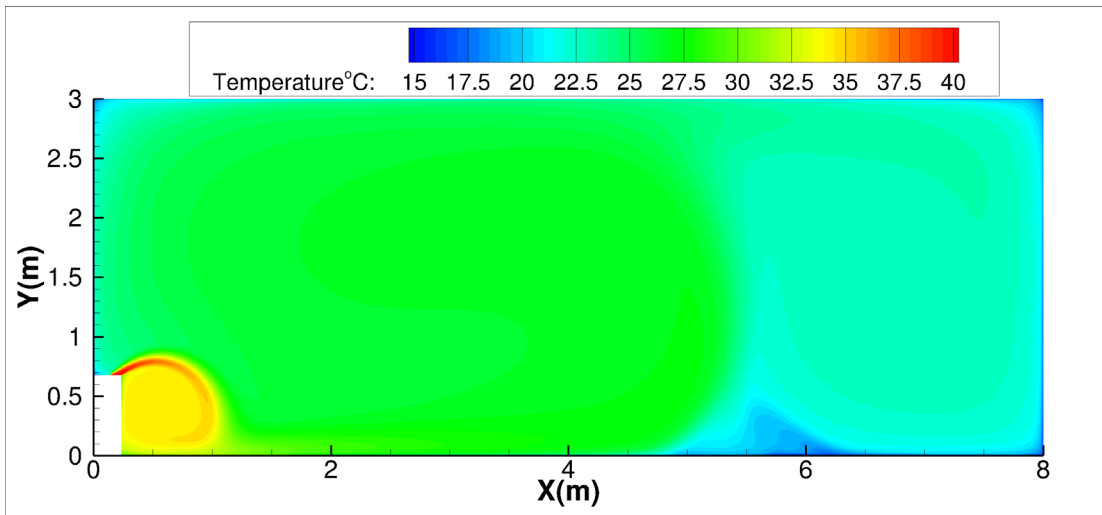

Discharge Angle 60°

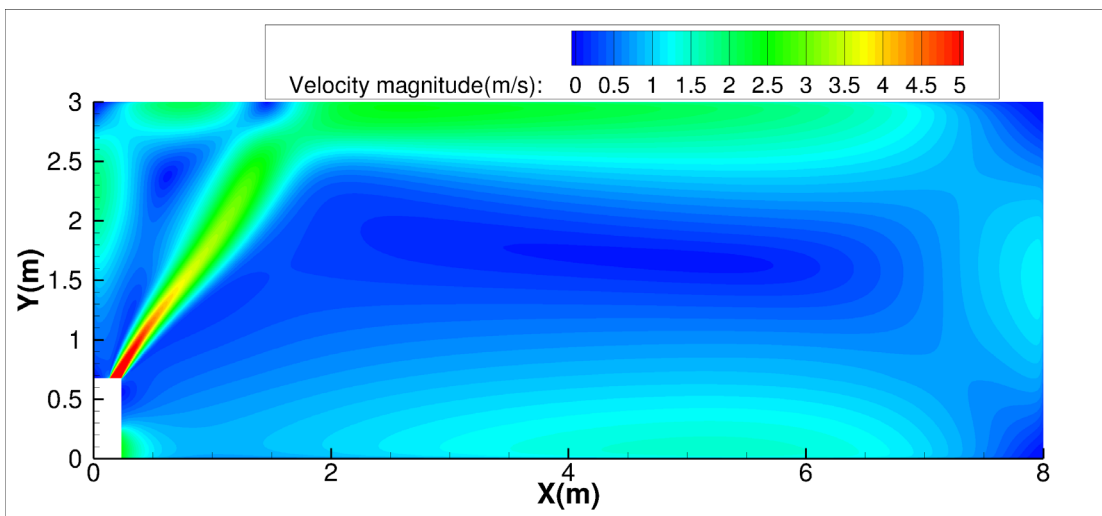
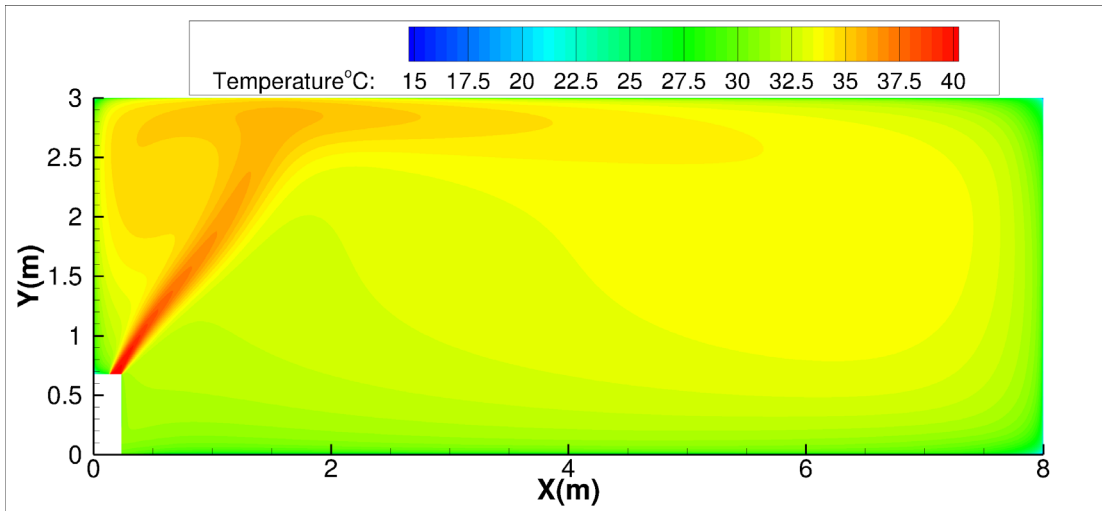

9. Electric Characteristics

Model	Indoor Unit			
	Hz	Voltage	Min.	Max.
TPA-09	60	208-230V	187V	253V
CPA-09B	60	208-230V	187V	253V
TPA-12	60	208-230V	187V	253V
CPA-12B	60	208-230V	187V	253V
TIP24	60	208-230V	187V	253V
FPA-24	60	208-230V	187V	253V
CPA-24B	60	208-230V	187V	253V
FPA-36DU	60	208-230V	187V <td 253V	
CPA-36DUB	60	208-230V	187V	253V
TIP36	60	208-230V	187V	253V
TIP48	60	208-230V	187V	253V
FPA-48DU	60	208-230V	187V	253V
CPA-48DUB	60	208-230V	187V	253V
CPA-60DU	60	208-230V	187V	253V
FPA-60DU	60	208-230V	187V	253V

10. Sound Level

10.1 Indoor unit

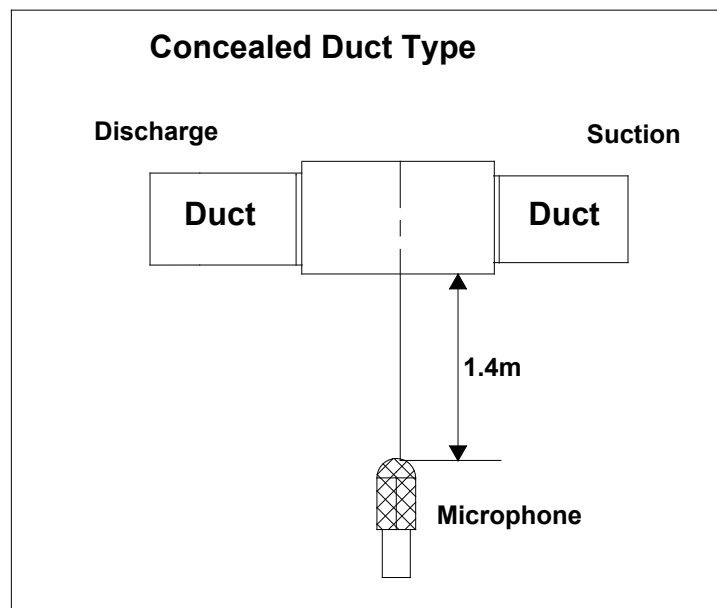

Model	Noise level dB(A)		
	H	M	L
CPA-09B	37	32	30
CPA-12B	38	33	30
CPA-18B	39	37	35
CPA-24B	44	40	35
CPA-36DUB	46	42	39
CPA-48DUB	52	49	46
CPA-60DU	57	54	51

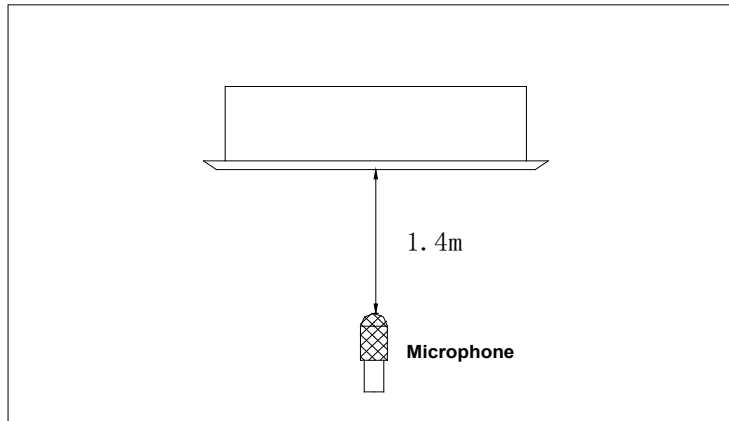

Model	Noise level dB(A)		
	H	M	L
TPA-09	41	39	37
TPA-12	41	38	35
TPA-18	46	43	41
TIP24	49	46	43
TIP36	52.5	50	46.5
TIP48	55	53	50

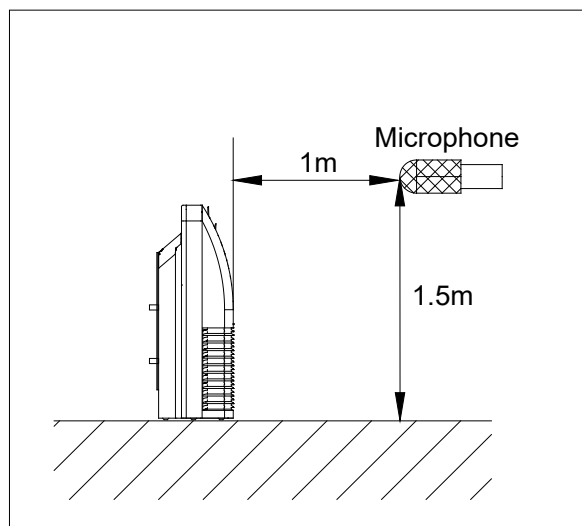
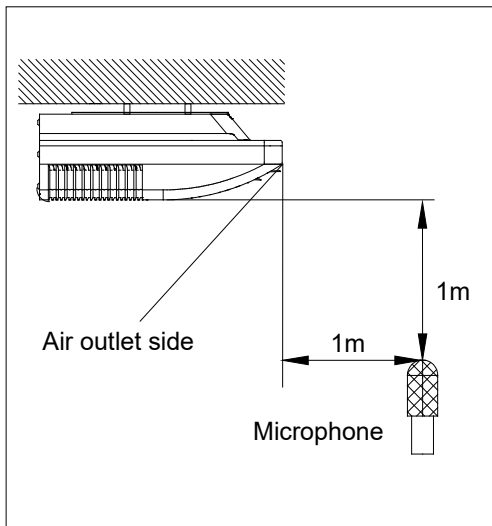

Model	Noise level dB(A)		
	H	M	L
FPA-18	47	44	38
FPA-24	53	49	45
FPA-36DU	55	48	41
FPA-48DU	57	54	52
FPA-60DU	55	49	46

10.2 Outdoor unit

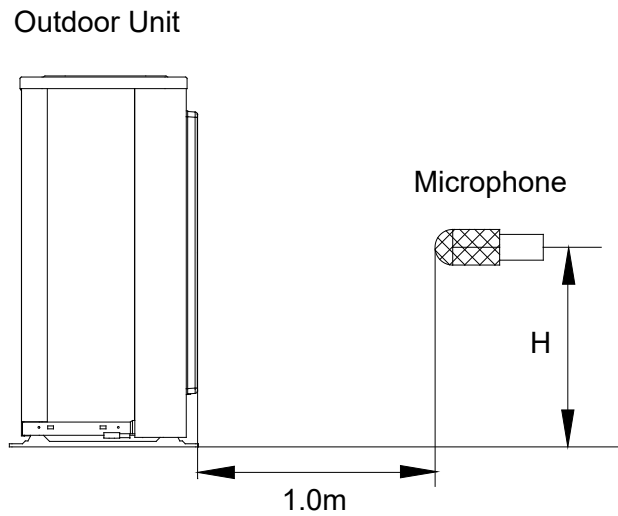







Note: $H = 0.5 \times \text{height of outdoor unit}$

Model	Noise Level dB(A)
CZP09CD(O)	55
CZP12CD(O)	54
CHF09CD(O)	55
CHF12CD(O)	54
CHF18CD(O)	59
CZP18CD(O)	60.5
CHF24CD(O)	62.5
CZP24CD(O)	61
CHF36CD(O)	65
CZP48CD(O)	65
CHF48CD(O)	66.5
CZP60CD(O)	65







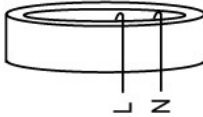





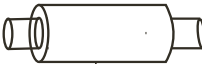

11. Accessories

Duct Units

	Name	Shape	Quantity
Tubing & Fittings	Soundproof / insulation sheath		2
	Binding tape		1
	Seal sponge		1



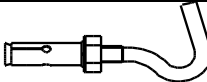

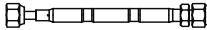
Drainpipe Fittings (for cooling & heating)	Drain joint		1
	Seal ring		1
Wired controller & Its Frame	Wired controller		1
Others	Manual		2-3
EMS & It's fitting	Magnetic ring (twist the electric wires L and N around it to five circles)		1

Cassette Units





	Name	Shape	Quantity
Installation Fittings	Installation paper board		1
Tubing & Fittings	Soundproof / insulation sheath		1
Drainpipe Fittings	Out-let pipe sheath		1
	Out-let pipe clasp		1
	Drain joint		1
	Seal ring		1
Remote controller & Its Frame (The product you have might not be provided the following accessories)	Remote controller & Its Frame		1
	Remote controller holder		1
	Mounting screw(ST2.9×10-C-H)		2
	Remote controller manual		1
	Alkaline dry batteries (AM4)		2
Others	Manual		2-3
Installation accessory (The product you have might not be provided the following accessories)	Expansive hook		4
	Installation hook		4
	Orifice		1

Console Units

	Name	Shape	Quantity
Installation fittings	Hook		2

Remote controller & Its Frame	Remote controller		1
	Frame		1
	Mounting screw(ST2.9×10-C-H)		2
	Alkaline dry batteries (AM4)		2
Others	Manual	/	2~3

Ceiling-floor Units

	Name	Shape	Quantity
Remote controller & Its holder	1. Remote controller		1
	2. Remote controller holder		1
	3. Mounting screw (ST2.9×10-C-H)		2
	4. Alkaline dry batteries (AM4)		2
Others	5. Manual		2-3

12. The Specification of Power

Type		9K-18K	24K
Power	Phase	1-phase	1-phase
	Frequency and Voltage	208-230V, 60Hz	208-230V, 60Hz
Circuit Breaker/ Fuse (A)		25/20	25/20
Indoor Unit Power Wiring		—————	—————
Indoor/Outdoor Connecting Wiring	Outdoor Unit Power Wiring	3-core cable (14AWG)	3-core cable (14AWG)
	Strong Electric Signal	4-core cable (16AWG)	4-core cable (16AWG)
		4-core cable (14AWG)(with auxiliary electric heater)	4-core cable (14AWG)(with auxiliary electric heater)
	Weak Electric Signal	—————	—————

Model		36K	48K/60k
Power	Phase	1-phase	1-phase
	Frequency and Voltage	208-230V, 60Hz	208-230V, 60Hz
Circuit Breaker/ Fuse (A)		40/30	50/40
Indoor Unit Power Wiring		—————	—————
Indoor/Outdoor Connecting Wiring	Outdoor Unit Power Wiring	3-core cable 12AWG	3-core cable 10AWG
	Strong Electric Signal	3-core cable 16AWG	3-core cable 16AWG
		4-core cable (14AWG)(with auxiliary electric heater)	4-core cable (14AWG)(with auxiliary electric heater)
	Weak Electric Signal	2-core shielded cable 24AWG	2-core shielded cable 24AWG

13. Field Wiring

9K~24K

Air Condition Link-Circuit

1602300007042

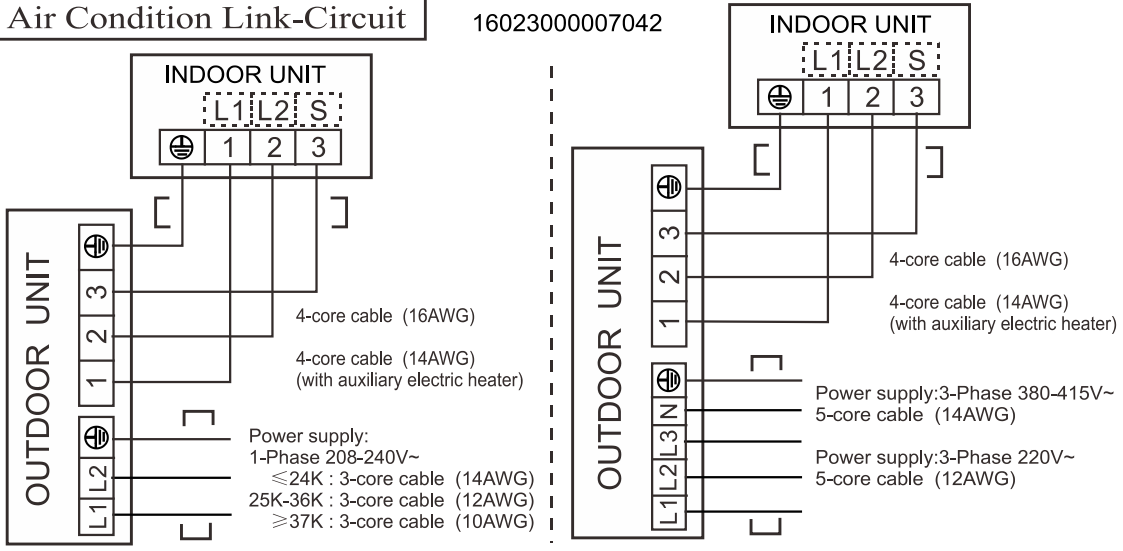

36K, 48K

Air Condition Link-Circuit

202070790610

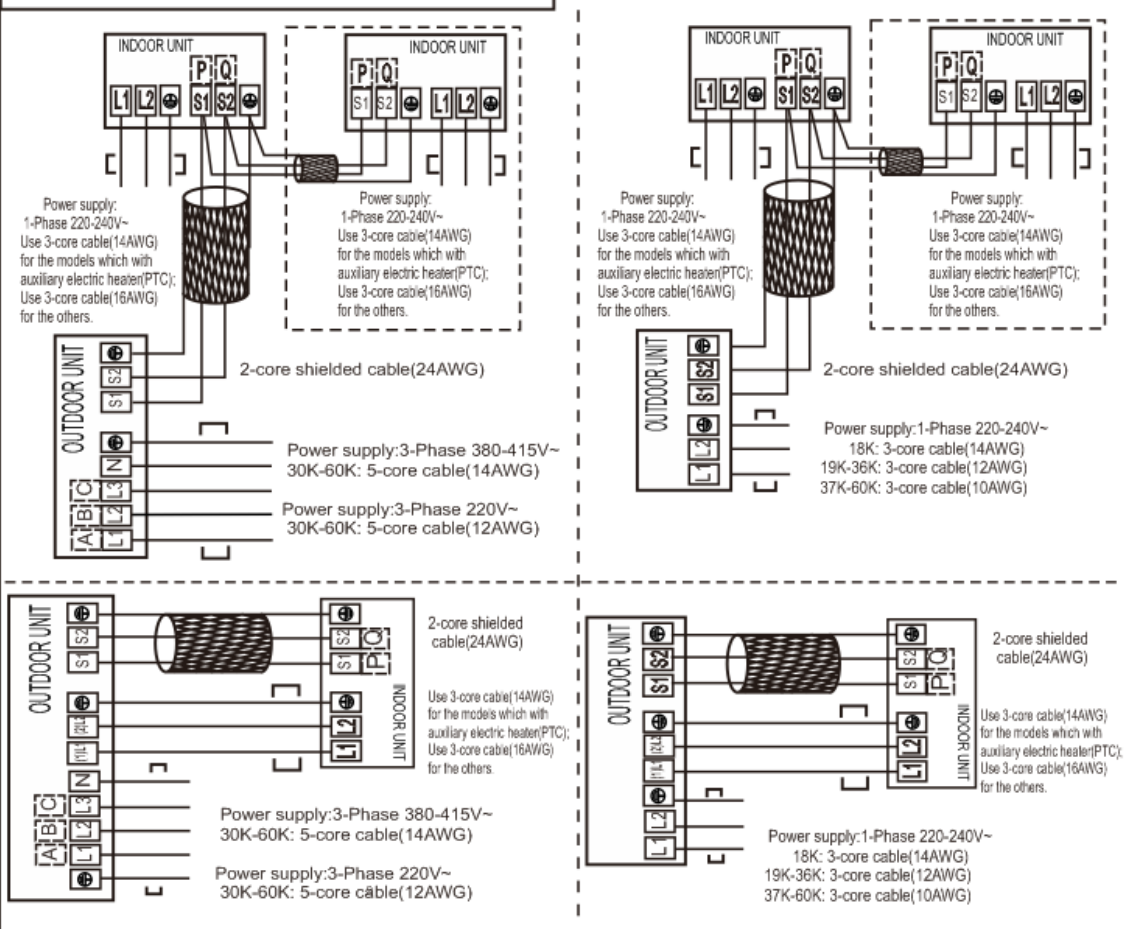

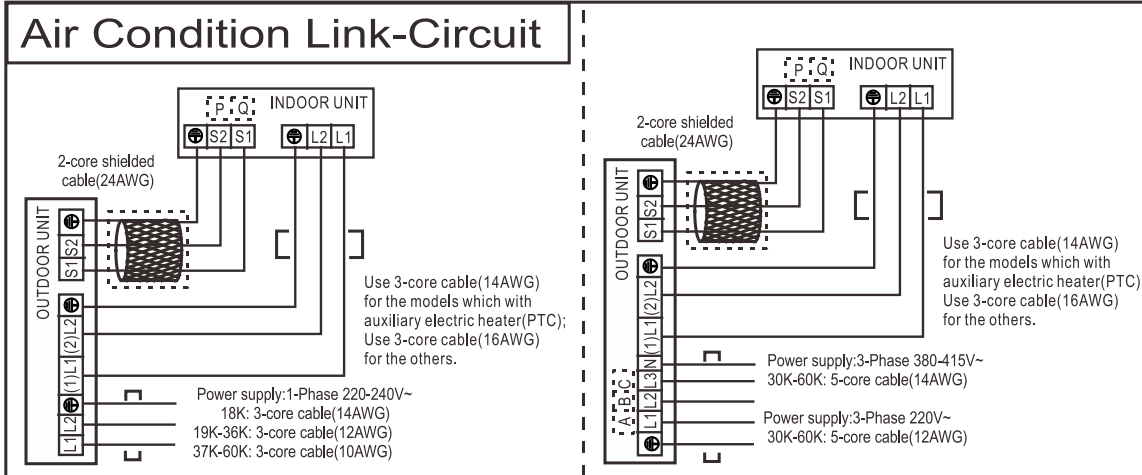

14 .Installation Details

14.1Location selection

14.1.1 Indoor unit location selection

- The place shall easily support the indoor unit's weight.
- The place can ensure the indoor unit installation and inspection.
- The place can ensure the indoor unit horizontally installed.
- The place shall allow easy water drainage.
- The place shall easily connect with the outdoor unit.
- The place where air circulation in the room should be good.
- There should not be any heat source or steam near the unit.
- There should not be any oil gas near the unit
- There should not be any corrosive gas near the unit
- There should not be any salty air neat the unit
- There should not be strong electromagnetic wave near the unit
- There should not be inflammable materials or gas near the unit
- There should not be strong voltage vibration.

14.1.2 Outdoor unit location selection

- The place shall easily support the outdoor unit's weight.
- Locate the outdoor unit as close to indoor unit as possible
- The piping length and height drop cannot exceed the allowable value.
- The place where the noise, vibration and outlet air do not disturb the neighbors.
- There is enough room for installation and maintenance.
- The air outlet and the air inlet are not impeded, and not face the strong wind.
- It is easy to install the connecting pipes and cables.
- There is no danger of fire due to leakage of inflammable gas.
- It should be a dry and well ventilation place
- The support should be flat and horizontal
- Do not install the outdoor unit in a dirty or severely polluted place, so as to avoid

blockage of the heat exchanger in the outdoor unit.

- If is built over the unit to prevent direct sunlight, rain exposure, direct strong wend, snow and other scraps accumulation, make sure that heat radiation from the condenser is not restricted.

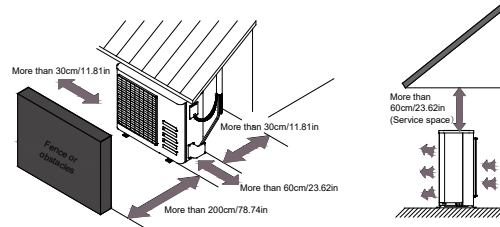

14.2 Indoor unit installation

14.2.1 FPA Duct indoor unit installation

14.2.1.1 Service space for indoor unit

FPA Duct

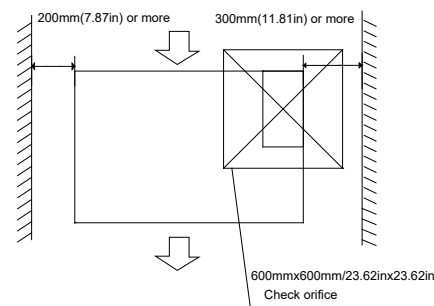

14.2.1.2 Bolt pitch

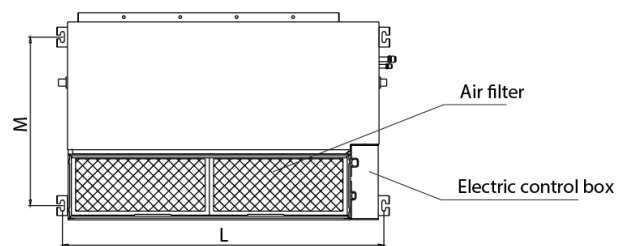

Model	Size of outline dimension mounted plug	
	L	M
	48.82	19.69
CPA-09B/ CPA-12B	741	360
	29.2	14.2
CPA-18B	920	508
	36.22	20
CPA-24B	1140	598
	44.88	23.54
CPA-36DUB	1400	598
	55.12	23.54
CPA-48DUB	1240	697
	48.82	27.44

14.2.1.3 Hang indoor unit

1. Please refer to the upper data to locate the four positioning screw bolt hole on the ceiling. Be sure to mark the areas where ceiling hook holes will be drilled.
2. Install and fit pipes and wires after you have finished installing the main body. When choosing where to start, determine the direction of the pipes to be drawn out. Especially in cases where there is a ceiling involved, align the refrigerant pipes, drain pipes, and indoor and outdoor lines with their connection points before mounting the unit.
3. Install hanging screw bolts.
 - Cut off the roof beam.
 - Strengthen the place that has been cut off, and consolidate the roof beam.
4. After you select an installation location, align the refrigerant pipes, drain pipes, as well as indoor and outdoor wires with their connection points before mounting the unit.
5. Drill 4 holes 10cm (4") deep at the ceiling hook positions in the internal ceiling. Be sure to hold the drill at a 90° angle to the ceiling.
6. Secure the bolt using the washers and nuts provided.
7. Install the four suspension bolts.
8. Mount the indoor unit with at least two people to lift and secure it. Insert suspension bolts into the unit's hanging holes. Fasten them using the washers and nuts provided.

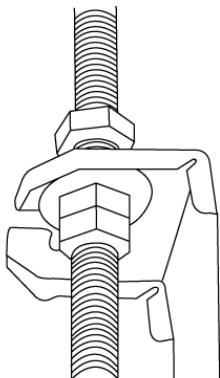

9. Mount the indoor unit onto the hanging screw bolts with a block. Position the indoor unit flat using a level indicator to prevent leaks.

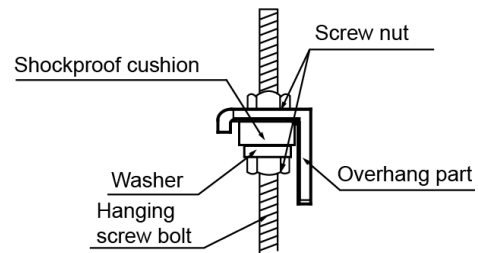

Note: Confirm the minimum drain tilt is 1/100 or more.

14.2.1.4 Duct and accessories installation

1. Install the filter (optional) according to the size of the air inlet.
2. Install the canvas tie-in between the body and the duct.
3. Air inlet and air outlet duct should be apart far enough to avoid air passage short-circuit.
4. Connect the duct according to the following diagram.

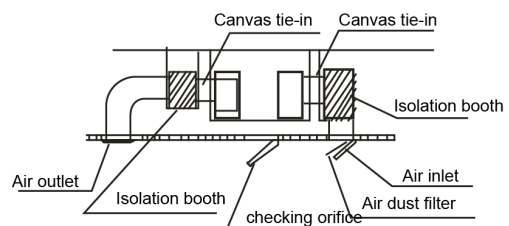

5. Please refer to the following static pressure to install.

Model	Static Pressure(Pa)
CPA-18B	0-100
CPA-24B	0-160
CPA-36DUB	0-160
CPA-48DUB	0-160

Change the fan motor static pressure corresponding to external duct static pressure.

NOTE: 1. Do not put the connecting duct weight on the indoor unit.

2. When connecting duct, use inflammable canvas tie-in to prevent vibrating.

3. Insulation foam must be wrapped outside the duct to avoid condensate. An internal duct underlayer can be added to reduce noise, if the end-user requires.

14.2.1.5 Adjust the air inlet direction (From rear side to under-side)

1. Take off ventilation panel and flange, cut off the staples at side rail

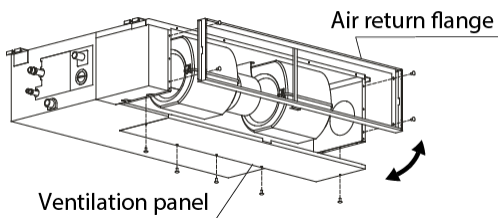

2. Change the mounting positions of ventilation panel and air return flange .

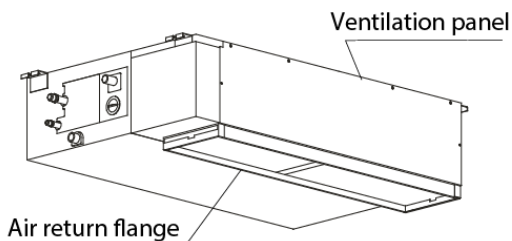

3. When installing the filter mesh, fit it into the flange as illustrated in the following figure.

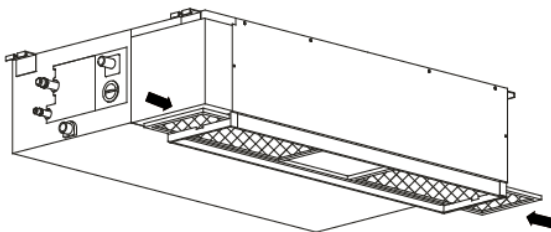

NOTE: All the figures in this manual are for demonstration purposes only. The air conditioner you have purchased may be slightly different in design, though similar in shape.

14.2.1.7 Fresh air duct installation

Dimension :

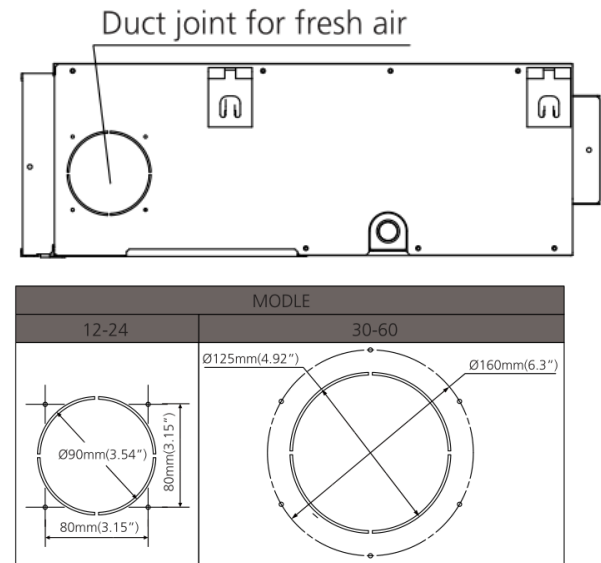

14.2.2 Compact cassette indoor unit installation

14.2.2.1 Service space for indoor unit

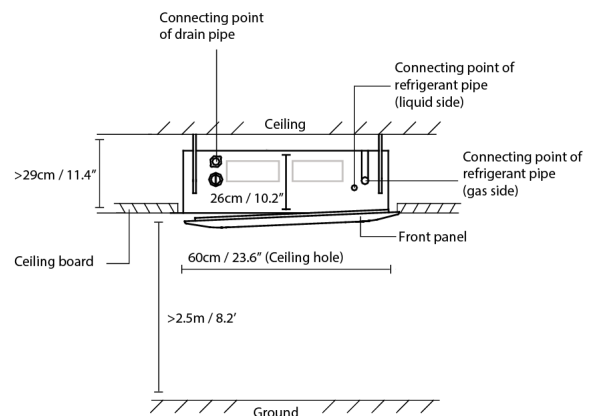
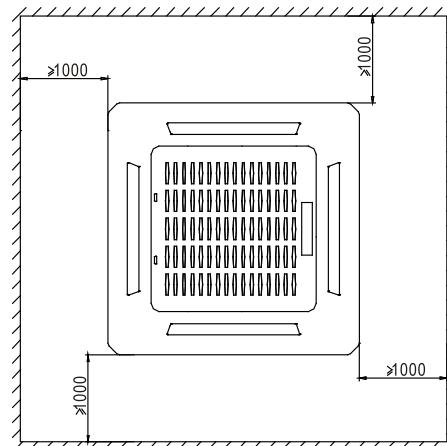

14.2.2.2 Bolt pitch

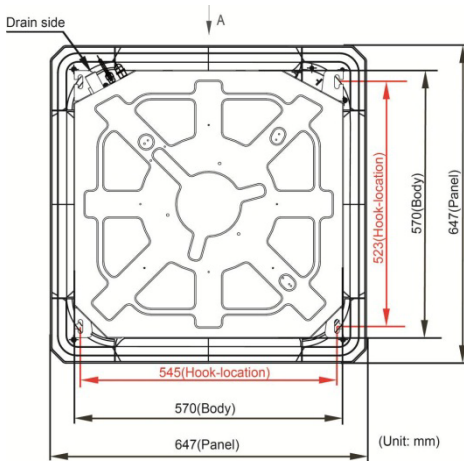

14.2.2.3 Install the pendant bolt

Select the position of installation hooks according to the hook holes positions showed in upper picture.

Drill four holes of $\varnothing 12\text{mm}$, 45~50mm deep at the selected positions on the ceiling. Then embed the expansible hooks (fittings).



Face the concave side of the installation hooks toward the expansible hooks. Determine the length of the installation hooks from the height of ceiling, then cut off the unnecessary part.

If the ceiling is extremely high, please determine the length of the installation hook depending on the real situation.

14.2.2.4 Install the main body

Make the 4 suspender through the 4 hanger of the main body to suspend it. Adjust the hexangular nuts on the four installation hooks evenly, to ensure the balance of the body. Use a leveling instrument to make sure the levelness of the main body is within $\pm 1^\circ$.

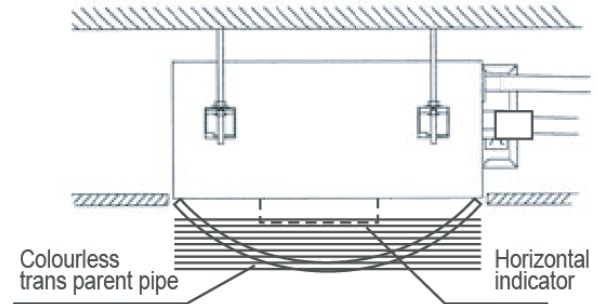

Adjust the position to ensure the gaps between the body and the four sides of ceiling are even. The body's lower part should sink into the ceiling for 24 mm. In general, L is half of the screw length of the installation hook.

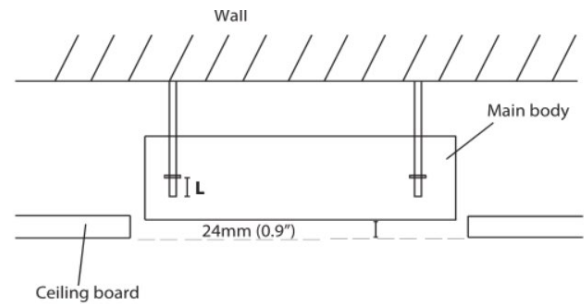

Locate the air conditioner firmly by wrenching the nuts after having adjusted the body's position well.

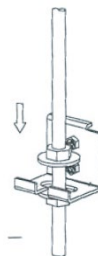

14.2.2.5 Install the panel

Remove the grille

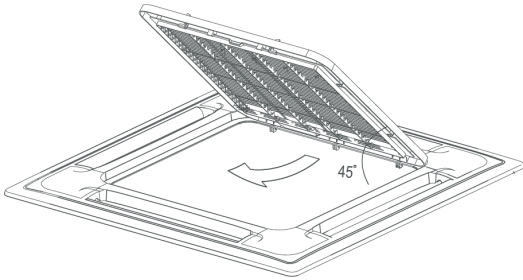
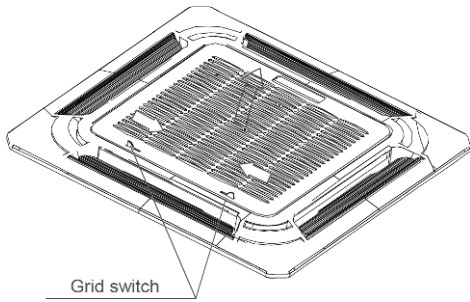

Hang the panel to the hooks on the mainbody.

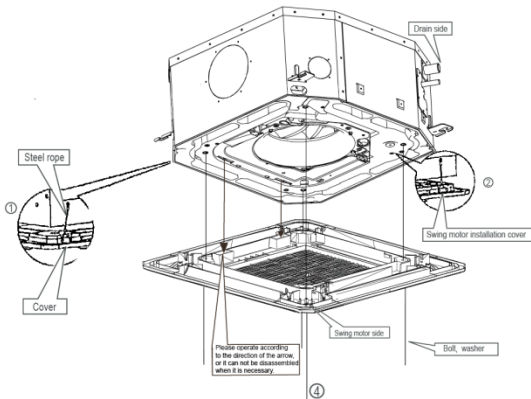

Tighten the screws under the panel hooks till the panel closely stick on the ceiling to avoid condensate water.

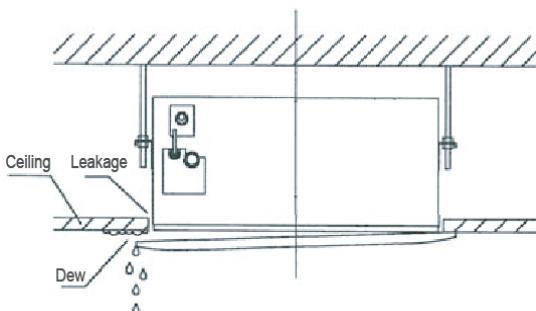
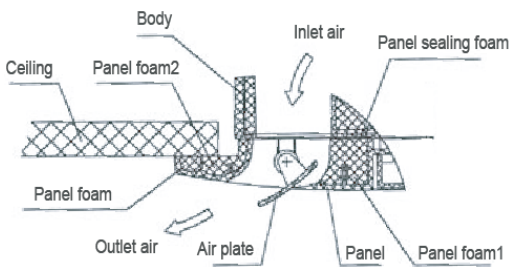

Hang the air-in grill to the panel, then connect the lead terminator of the swing motor and that of the control box with corresponding terminators on the body respectively.

Note: The panel shall be installed after the wiring connected.

14.2.3 Console indoor unit installation

14.2.3.1 Service space for indoor unit

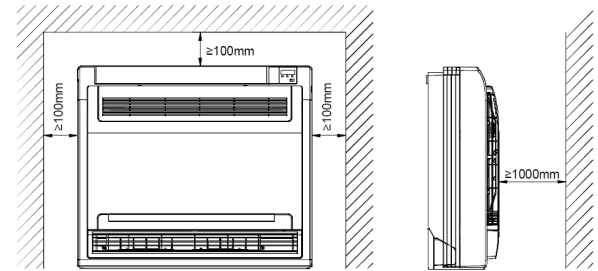

14.2.3.2 Install the main body

- Fix the hook with tapping screw onto the wall

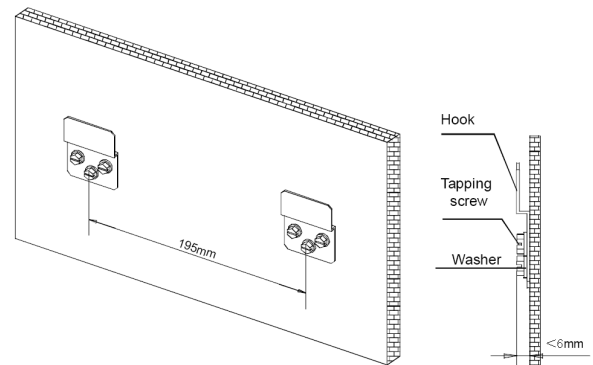

- Hang the indoor unit on the hook.
(The bottom of body can touch with floor or suspended, but the body must install vertically.)

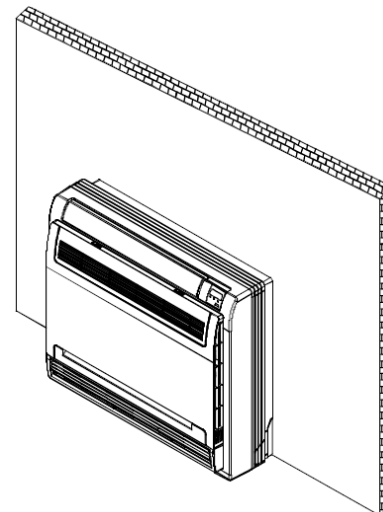

14.2.4 Ceiling-floor unit installation

14.2.4.1 Service space for indoor unit

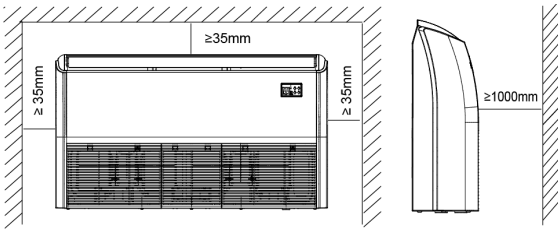

14.2.4.2 Bolt pitch

① Ceiling installation

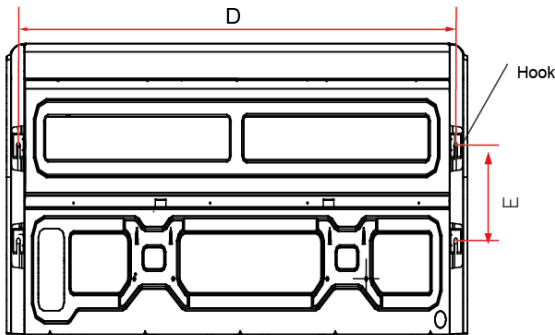

Capacity (Btu/h)	Unit	D	E
18K / 24K	mm	983	220
	inch	38.70	8.66
36K	mm	1200	220
	inch	47.24	8.66
48K/60K	mm	1565	220
	inch	61.61	8.66

② Wall-mounted installation

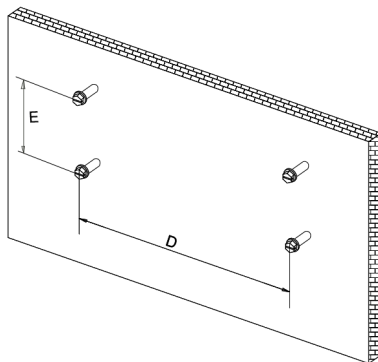

14.2.4.3 Install the pendant bolt

① Ceiling installation

Select the position of installation hooks according to the hook holes positions showed in upper picture.

Drill four holes of $\varnothing 12\text{mm}$, 45~50mm deep at the selected positions on the ceiling. Then embed the expansible hooks (fittings).



② Wall-mounted installation

Install the tapping screws onto the wall. (Refer to picture below)

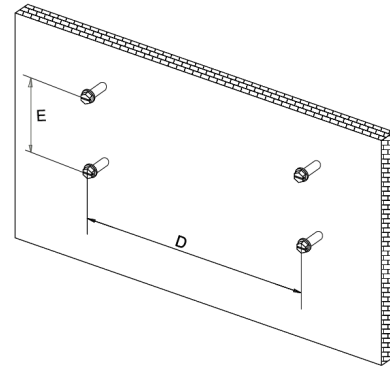

14.2.4.4 Install the main body

① Ceiling installation (The only installation method for the unit with drain pump)

Remove the side board and the grille.

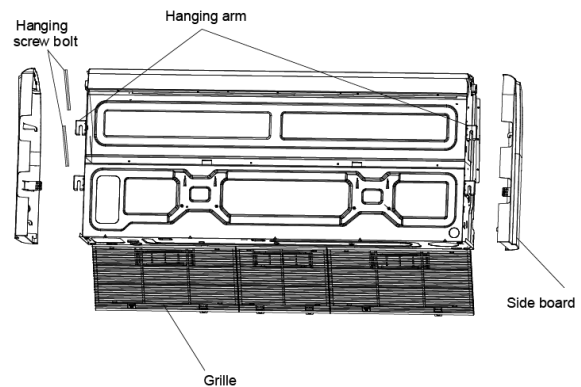

Locate the hanging arm on the hanging screw bolt. Prepare the mounting bolts on the unit.

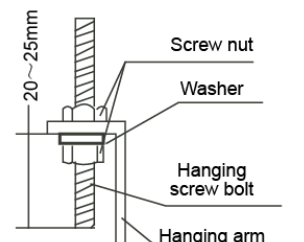

Put the side panels and grilles back.

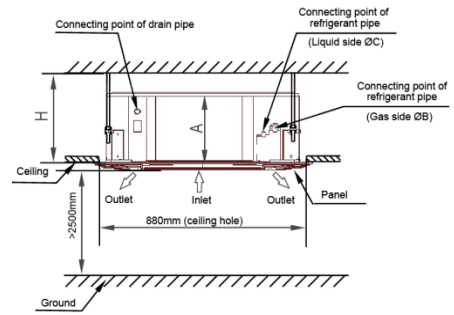
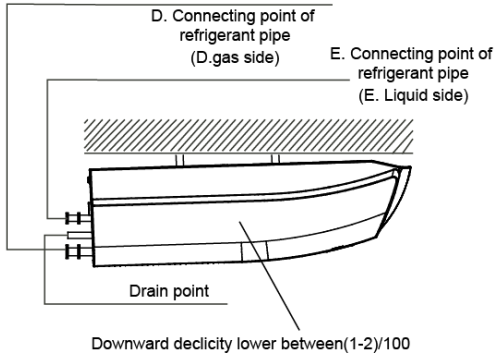
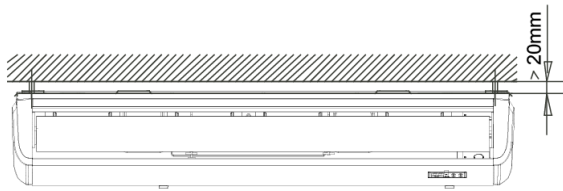

Capacity (Btu/h)		A	H
24K	mm	205	>235
	inch	8.07	>9.25
36K	mm	245	>275
	inch	9.65	>10.83
48K	mm	287	>317
	inch	11.30	>12.48

② Wall-mounted installation

Hang the indoor unit by insert the tapping screws into the hanging arms on the main unit. (The bottom of body can touch with floor or suspended, but the body must install vertically.)

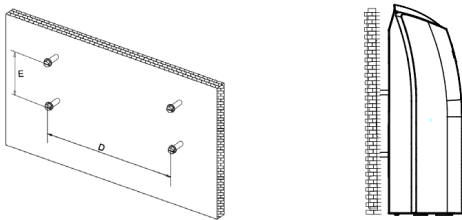

14.2.5 Slim cassette indoor unit installation

14.2.5.1 Service space for indoor unit

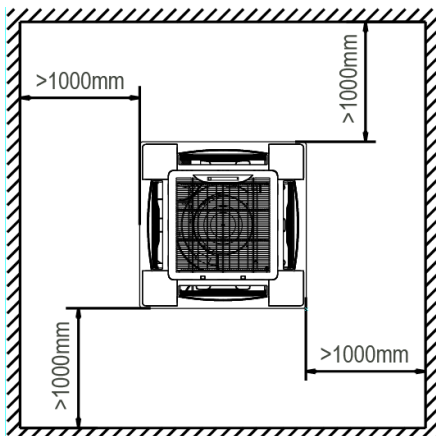

14.2.5.2 Bolt pitch

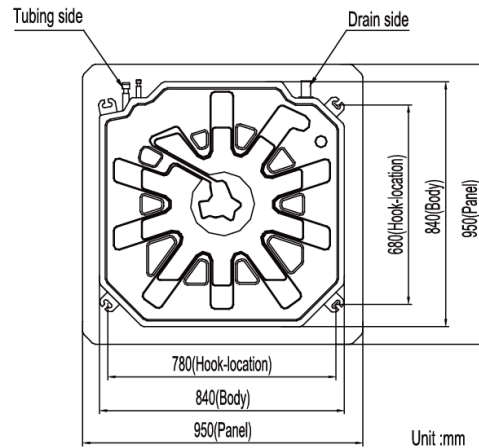

14.2.5.3 Install the pendant bolt

Select the position of installation hooks according to the hook holes positions showed in upper picture.

Drill four holes of $\varnothing 12\text{mm}$, 45~50mm deep at the selected positions on the ceiling. Then embed the expansible hooks (fittings).



14.2.5.4 Install the main body

Make the 4 suspender through the 4 hanger of the main body to suspend it. Adjust the

hexangular nuts on the four installation hooks evenly, to ensure the balance of the body. Use a leveling instrument to make sure the levelness of the main body is within $\pm 1^\circ$.



Adjust the position to ensure the gaps between the body and the four sides of ceiling are even. The body's lower part should sink into the ceiling for 10~18(0.4"~0.7") mm. In general, L is half of the screw length of the installation hook.

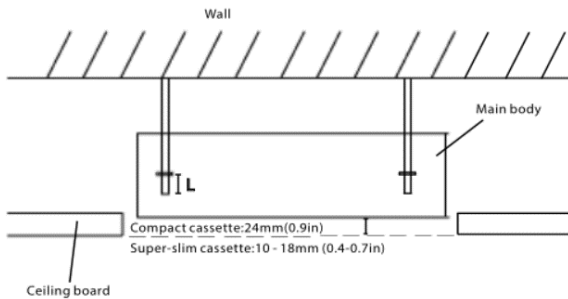

Locate the air conditioner firmly by wrenching the nuts after having adjusted the body's position well.

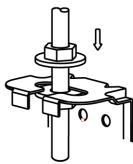

14.2.5.5 Install the panel

Remove the grille

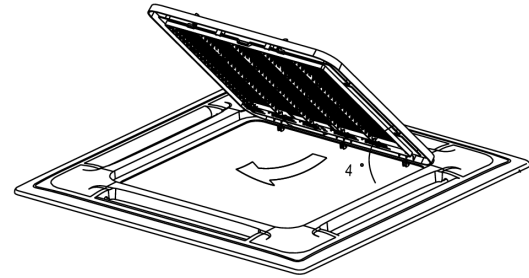
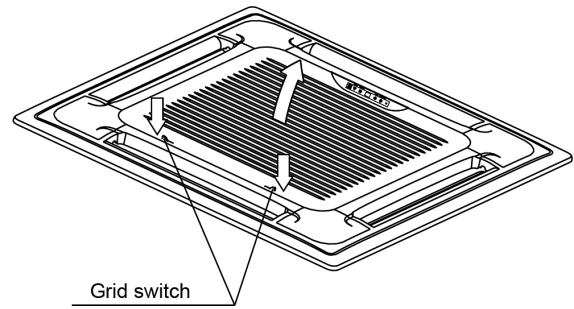

Remove the 4 corner covers.

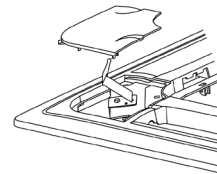

Hang the panel to the hooks on the mainbody. If the panel is with auto-lift grille, please watch the ropes lifting the grille, DO NOT make the ropes entwined or blocked.

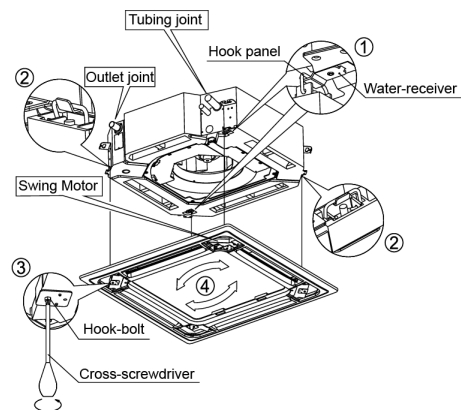

Tighten the screws under the panel hooks till the panel closely stick on the ceiling to avoid condensate water.

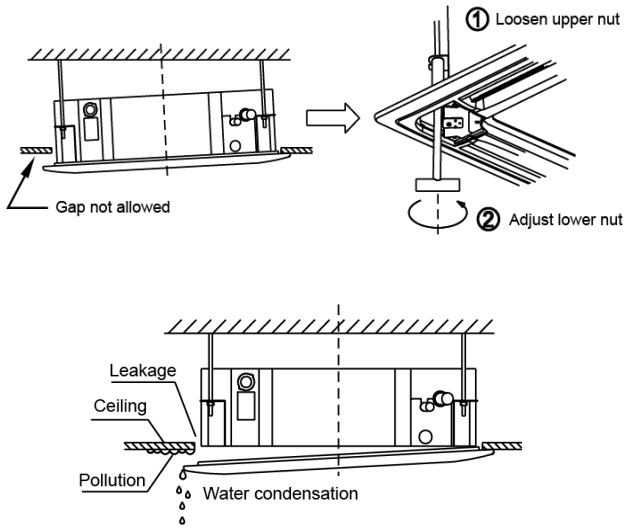

Hang the air-in grill to the panel, then connect the lead terminator of the swing motor and that of the control box with corresponding terminators on the body respectively.

Install the 4 corner covers back.

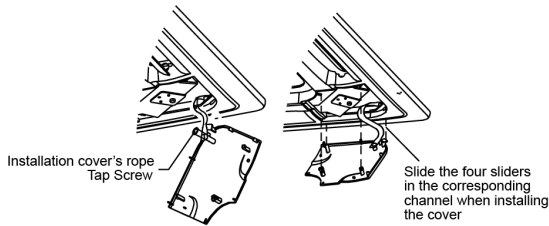

Note: The panel shall be installed after the wiring connected.

14.2.6 HESP duct indoor unit installation

14.2.6.1 Service space for indoor unit

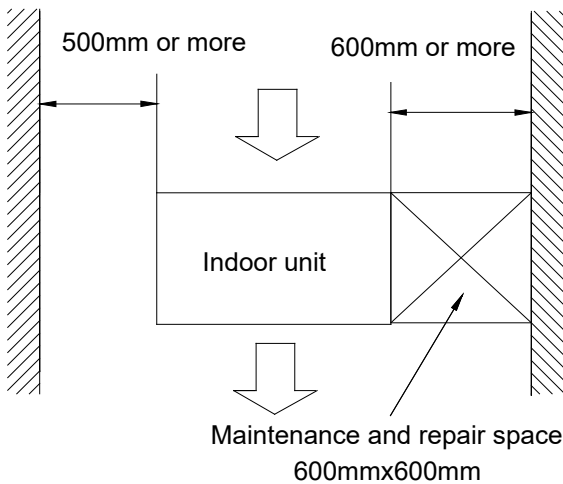

14.2.6.2 Bolt pitch

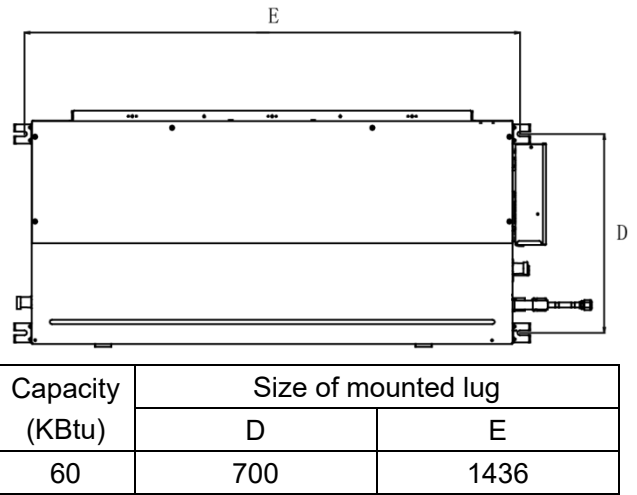

14.2.6.3 Install the pendant bolt

Select the position of installation hooks according to the hook holes positions showed in upper picture.

Drill four holes of $\text{Ø}12\text{mm}$, 45~50mm deep at the selected positions on the ceiling. Then embed the expansible hooks (fittings).



14.2.6.4 Install the main body

Make the 4 suspender through the 4 hanger of the main body to suspend it. Adjust the hexangular nuts on the four installation hooks evenly, to ensure the balance of the body. Use a leveling instrument to make sure the levelness of the main body is within $\pm 1^\circ$.



Capacity (kBtu/h)	A(mm/inch)	H(mm/inch)	B(mm/inch)
24	205/8.07	>230/9.06	900/35.4
36	245/9.65	>271/10.7	
48	287/11.3	>313/12.3	

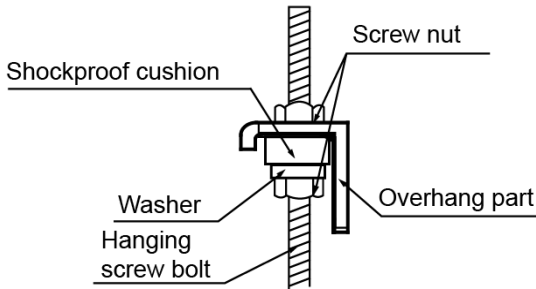

14.2.6.5 Install the air duct

Please design the air duct as below recommended picture

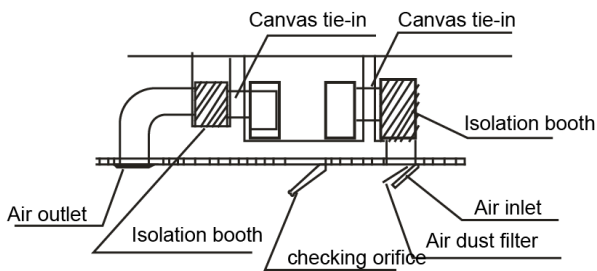

14.2.7 New cassette indoor unit installation

14.2.7.1 Service space for indoor unit

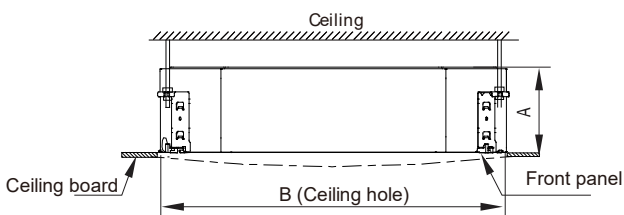
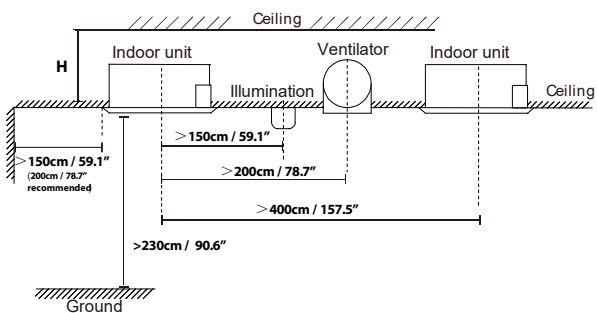

14.2.7.2 Bolt pitch

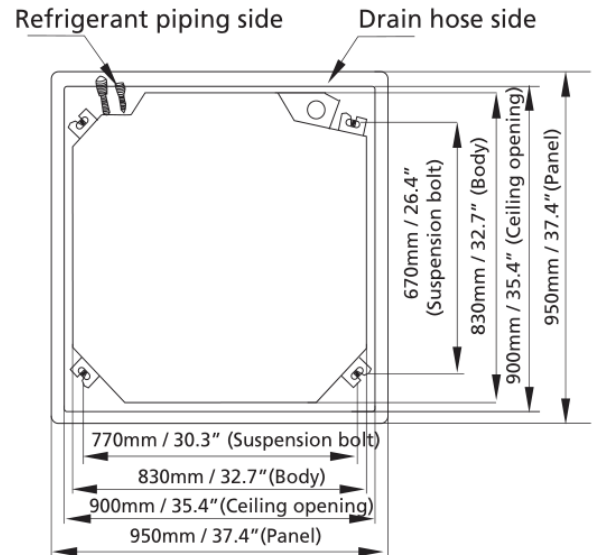

14.2.7.3 Install the pendant bolt

Select the position of installation hooks according to the hook holes positions showed in upper picture.

Drill four holes of $\varnothing 12\text{mm}$, 12 cm ~15.5cm(4.7"-6.1") deep at the ceiling hook positions in the internal ceiling. Be sure to hold the drill at a 90° angle to the ceiling.

Using a hammer, insert the ceiling hooks into the pre-drilled holes. Secure the bolt using the included washers and nuts.

Install the four suspension bolts.



14.2.5.4 Install the main body

Make the 4 suspender through the 4 hanger of the main body to suspend it. Adjust the

hexangular nuts on the four installation hooks evenly, to ensure the balance of the body. Use a leveling instrument to make sure the levelness of the main body is within $\pm 1^\circ$.



Adjust the position to ensure the gaps between the body and the four sides of ceiling are even. The body's lower part should sink into the ceiling for 10~25 mm (0.4-0.98"). In general, L is half of the screw length of the installation hook.

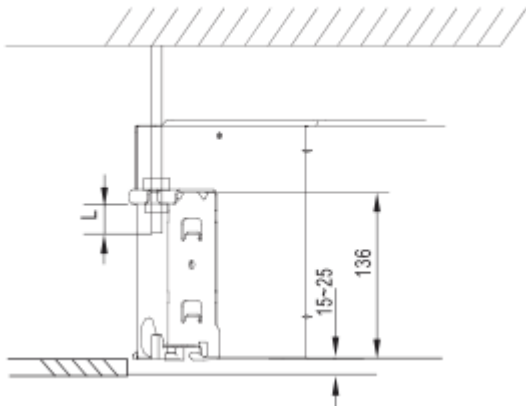

Locate the air conditioner firmly by wrenching the nuts after having adjusted the body's position well.

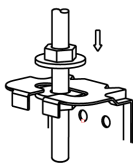

14.2.5.5 Install the panel

Remove the front grille

1. Push one side of the grille screw cover then remove the grid screw.
2. Push both of the tabs towards the middle simultaneously to unlock the hook on the grille.
3. Hold the grille at a 45° angle, lift it up slightly and detach it from the main body.

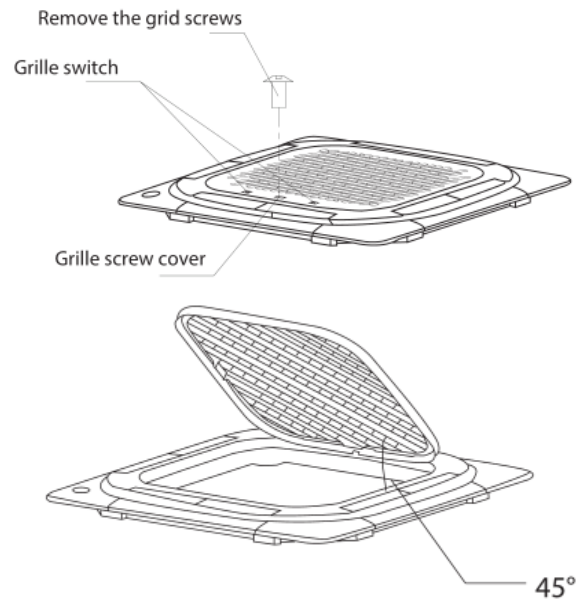

Remove the 4 corner covers.

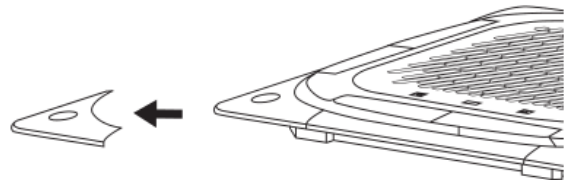

Install the panel

1. Align the front panel to the main body, taking into account the position of the piping and drain sides. Hang the four latches of the decorative panel to the hooks of the indoor unit. Tighten the panel hook screws evenly at the four corners.

Note: Tighten the screws until the thickness of the sponge between the main body and the panel reduces to 4-6mm (0.2-0.3"). The edge of the panel should be in contact with the ceiling well.

2. Adjust the panel by turning it to the direction of arrow shown in figure below so that the ceiling opening is completely covered.

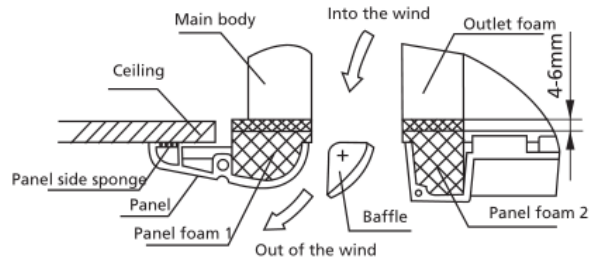
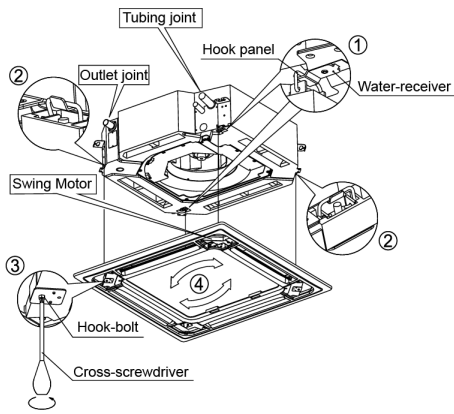

NOTE: If the height of the indoor unit needs to be adjusted, you can do so through the openings at the panel's four corners. Make sure that the internal wiring and drainpipe are not affected by this adjustment.

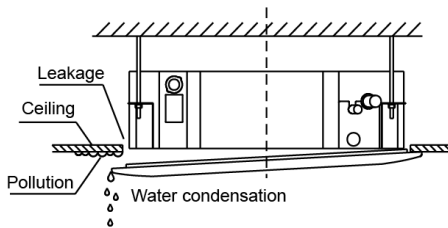

Failure to tighten screws can cause water leakage.

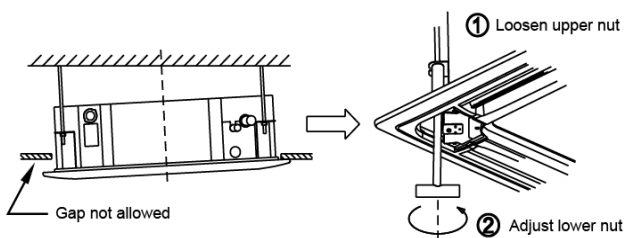

If the unit is not hung correctly and a gap exists, the unit's height must be adjusted to ensure proper function. The unit's height can be adjusted by loosening the upper nut, and adjusting the lower nut.

3. Hang the intake grille on the panel, and then connect the lead connectors of the louver motor

and the control box on the panel to the corresponding connectors of the main body.

4. Re-installed into the style grid.

5. Reinstall the installation cover.

Fix the installation cover plate rope to the pillar of the installation cover plate, and gently press the installation cover plate into the panel.

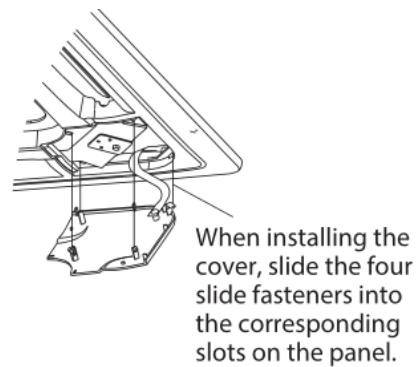
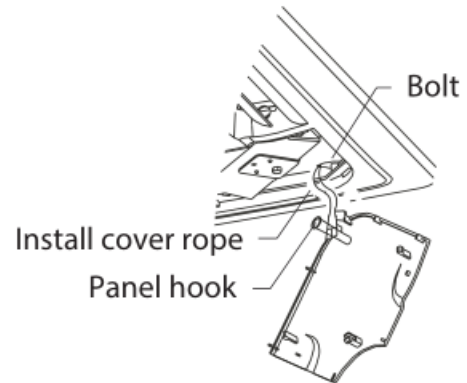

NOTE: After installation, the butt plugs of display, swing, water pump and other wire bodies must be placed in the electric control box.

14.3 Outdoor unit installation

14.3.1 Service space for outdoor unit

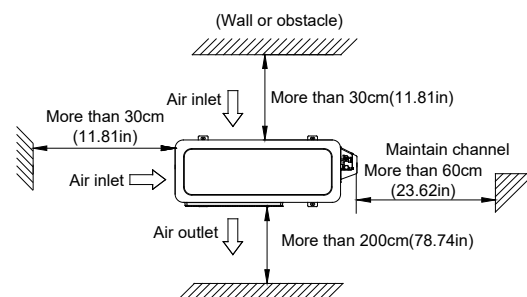

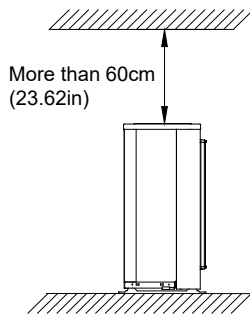

14.3.2 Bolt pitch

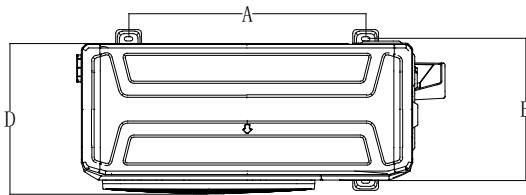

For the value of A, B and D, please refer to the dimension part.

14.3.3 Install the Unit

Since the gravity center of the unit is not at its physical center, so please be careful when lifting it with a sling.

Never hold the inlet of the outdoor unit to prevent it from deforming.

Do not touch the fan with hands or other objects.

Do not lean it more than 45°, and do not lay it sidelong.

Make concrete foundation according to the specifications of the outdoor units.

Fasten the feet of this unit with bolts firmly to prevent it from collapsing in case of earthquake or strong wind.

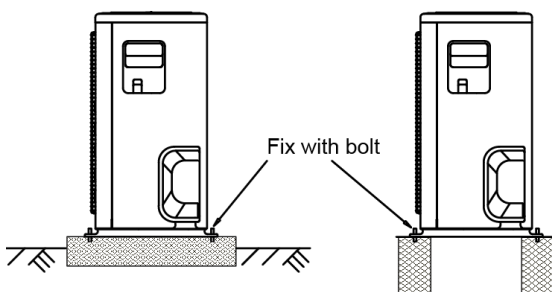

14.4 Refrigerant pipe installation

14.4.1 Maximum pipe length and height drop

Considering the allowable pipe length and height drop to decide the installation position. Make sure the distance and height drop between indoor and outdoor unit not exceeded the data in the following table.

Model	Max. Length		Max. Elevation	
	m	Ft.	m	Ft.
9,000Btu/h	25	82.2	10	32.9
12,000Btu/h	25	82.2	10	32.9
18,000Btu/h	30	98.7	20	65.8
24,000Btu/h	50	164.5	25	82.2
36,000Btu/h	65	213.8	30	98.7
48,000Btu/h	65	213.8	30	98.7
60,000Btu/h	65	213.8	30	98.7

14.4.2 The procedure of connecting pipes

1. Choose the pipe size according to the specification table.
2. Confirm the cross way of the pipes.
3. Measure the necessary pipe length.
4. Cut the selected pipe with pipe cutter
 - Make the section flat and smooth.

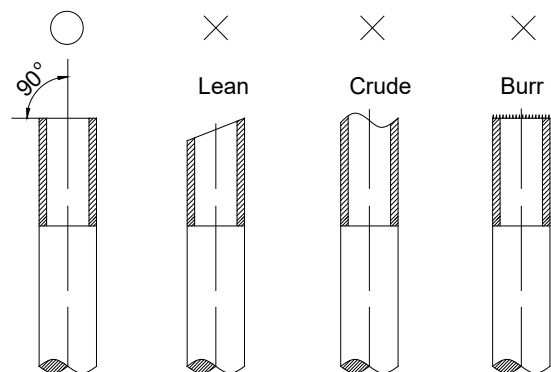

5. Insulate the copper pipe
 - Before test operation, the joint parts should not be heat insulated.
6. Flare the pipe
 - Insert a flare nut into the pipe before flaring the pipe
 - According to the following table to flare the pipe

Pipe diameter	Flare dimension A (mm)		Flare shape
	Min	Max	
1/4" (6.35)	8.3	8.7	
3/8" (9.52)	12.0	12.4	
1/2" (12.7)	15.4	15.8	
5/8" (15.9)	18.6	19.1	
3/4" (19)	22.9	23.3	

- After flared the pipe, the opening part must be seal by end cover or adhesive tape to avoid duct or exogenous impurity come into the pipe.
- 7. Drill holes if the pipes need to pass the wall.
- 8. According to the field condition to bend the pipes so that it can pass the wall smoothly.
- 9. Bind and wrap the wire together with the insulated pipe if necessary.
- 10. Set the wall conduit
- 11. Set the supporter for the pipe.
- 12. Locate the pipe and fix it by supporter
- For horizontal refrigerant pipe, the distance between supporters should not be exceed 1m.
- For vertical refrigerant pipe, the distance between supporters should not be exceed 1.5m.
- 13. Connect the pipe to indoor unit and outdoor unit by using two spanners.
- Be sure to use two spanners and proper torque to fasten the nut, too large torque will damage the flare, and too small torque may cause leakage. Refer the following table for different pipe connection.

Pipe Diameter	Torque		Sketch map
	(kgf.cm)	(N.cm)	
1/4" (6.35)	144~176	1420~1720	
3/8" (9.52)	333~407	3270~3990	
1/2" (12.7)	504~616	4950~6030	

5/8" (15.9)	630~770	6180~7540	
3/4" (19)	990~1210	9270~11860	

14.4.3 First-Time Installation

Air and moisture in the refrigerant system cause the following problems:

- Increases in system pressure
- Increases in operating current
- Decreases in cooling and heating efficiency
- Blocks in capillary tubing caused by moisture in the refrigerant circuit freezing
- Corrosion of parts in the refrigerant system caused by water

The indoor units and the pipes between indoor and outdoor units must be tested for leakages and evacuated to remove gas and moisture from the system.

Gas leak check with soap water:

Apply soap water or a liquid neutral detergent on the connections with a soft brush to check for leakage in the pipe connecting points. If bubbles emerge, the pipes are leaking.

1. Air Purging Using the Vacuum Pump

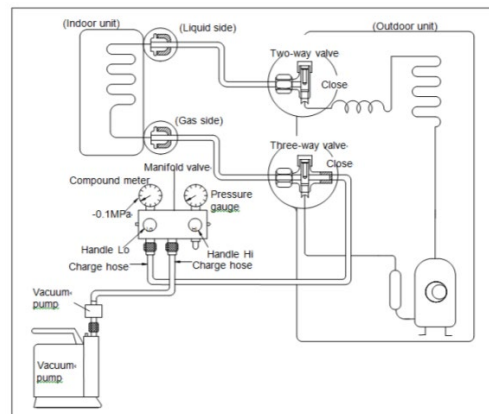

- 1) Completely tighten the flare nuts on the indoor and outdoor units. Confirm that both the 2-way and 3-way valves are set to the closed position.
- 2) Connect the charge hose with the push pin of the Handle Lo to the 3-way valve gas service port.
- 3) Connect the charge hose of the Handle Hi to the vacuum pump.

- 4) Fully open the Handle Lo of the manifold valve.
- 5) Turn on the vacuum pump to begin evacuation.
- 6) Conduct a 30-minute evacuation. Check whether the compound meter indicates $-0.1\text{Mpa}(14.5\text{Psi})$. If the meter does not indicate $-0.1\text{Mpa}(14.5\text{Psi})$ after 30 minutes has elapsed, continue evacuation for 20 more minutes. If the pressure does not reach $-0.1\text{Mpa}(14.5\text{Psi})$ after 50 minutes has elapsed, check if there are any leaks.

Fully close the Handle Lo valve of the manifold valve and turn off the vacuum pump. After 5 minutes, confirm that the gauge needle is not moving.

- 7) Turn the flare nut on the 3-way valve 45° counterclockwise for 6-7 seconds. Once gas begins to come out, tighten the flare nut. Make sure the pressure display on the pressure indicator is higher than atmospheric pressure. Then remove the charge hose from the 3-way valve.
- 8) Fully open the 2-way and 3-way valves and securely tighten the cap on the 3-way valve.

2. Air Purging Using Refrigerant

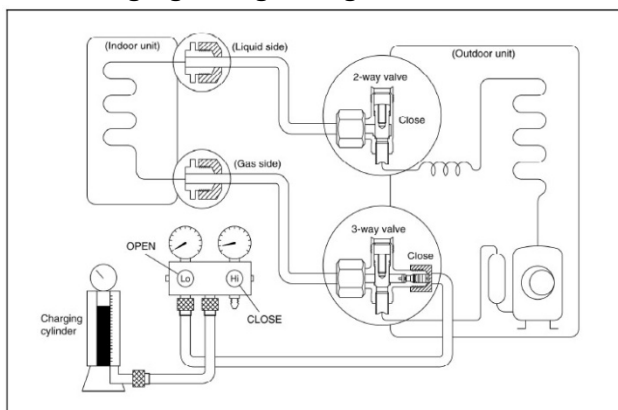

Procedure:

- 1). Confirm that both the 2-way and 3-way valves are set to the closed position.
- 2). Connect the charge set and a charging cylinder to the service port on the 3-way valve.
- 3). Air purging:
Open the valves on the charging cylinder and the charge set. Loosen the flare nut on the

2-way valve approximately 45° for 3 seconds then closing it for 1 minute. Repeat 3 times.

After purging the air, use a torque wrench to tighten the flare nut on the 2-way valve.

- 4). Check for gas leaks.

Check the flare connections for gas leaks.

- 5). Discharge the refrigerant.

Close the valve on the charging cylinder and discharge the refrigerant by loosening the flare nut on the 2-way valve approximately 45° until the gauge displays a value between 0.3 to 0.5 Mpa(43.5 to 72.5Psi)

- 6). Disconnect the charge set and the charging cylinder. Set the 2-way and 3-way valves to the open position.

Be sure to use a hexagonal wrench to open and close the valve stems.

- 7). Mount the valve stems nuts and the service port cap.

Be sure to use a torque wrench to tighten the service port cap to a torque of $18\text{N}\cdot\text{m}$.

Be sure to check for gas leaks.

14.4.4 Adding Refrigerant after Long-Term System Operation

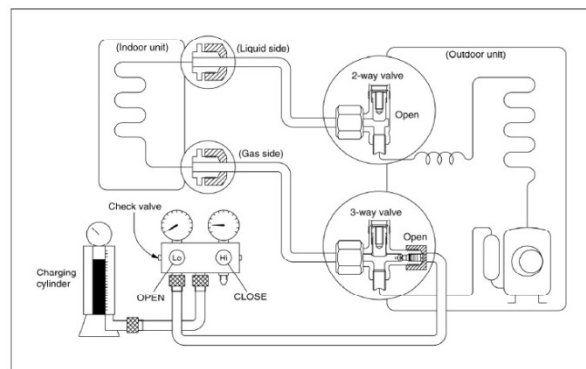

Procedure

- 1). Connect the charge hose to the 3-way service port and open the 2-way and 3-way valve.

Connect the charge hose to the valve at the bottom of the cylinder. If the refrigerant is R410A, place the cylinder bottom-up to ensure liquid charge.

- 2). Purge the air from the charge hose.

Open the valve at the bottom of the cylinder and press the check valve on the charge set to

nut on the 2-way valve approximately 45' until the gauge indicates 0.3 to 0.5 Mpa(43.5 to 72.5Psi)

6). Disconnect the charge set and the charging cylinder, and open the 2-way and 3-way valves
Be sure to use a hexagonal wrench to operate the valve stems.

7). Mount the valve stems nuts and the service port cap.

Be sure to use a torque wrench to tighten the service port cap to a torque 18N.m.

Be sure to check for gas leakage.

14.4.6 Re-Installation When the Outdoor Unit Requires Repairs

1. Evacuation for the whole system

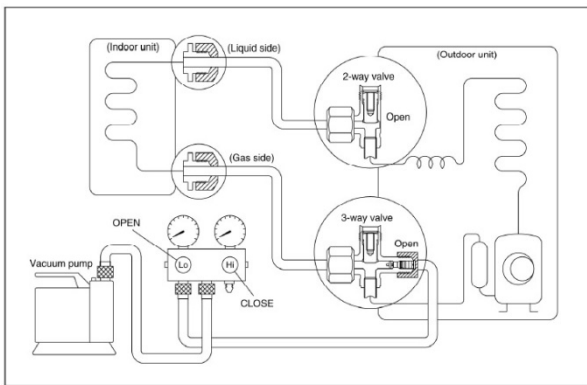

Procedure:

- 1). Confirm that both the 2-way and 3-way valves are open.
- 2). Connect the vacuum pump to 3-way valve's service port.
- 3). Conduct an evacuation for approximately one hour. Confirm that the compound meter displays a value of -0.1Mpa(14.5Psi).
- 4). Close the valve (Low side) on the charge set, turn off the vacuum pump. After 5 minutes, confirm that the gauge needle is not moving.
- 5). Disconnect the charge hose from the vacuum pump.

2. Refrigerant charging

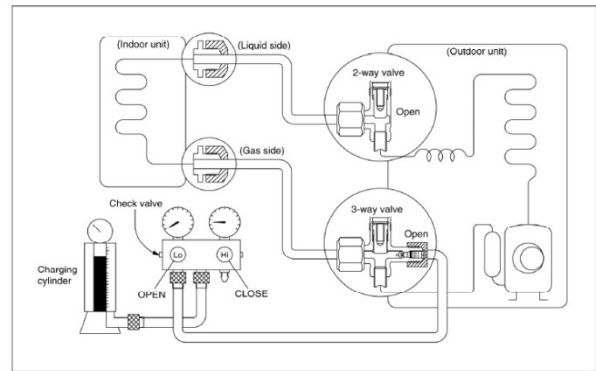

Procedure:

- 1). Connect the charge hose to the charging cylinder. Open the 2-way 3-way valve.
With the charge hose you disconnected from the vacuum pump, connect it to the valve at the bottom of the cylinder. If the refrigerant is R410A, place the cylinder bottom-up to ensure liquid charge.
- 2). To purge the air from the charge hose, open the valve at the bottom of the cylinder and press the check valve on the charge set (be careful of the liquid refrigerant).
- 3) Place the charging cylinder onto the electronic scale and record the weight.
- 4). Open the valves (Low side) on the charge set and charge the system with liquid refrigerant
If the system cannot be charged with the specified amount of refrigerant, or can be charged with a only a small amount at a time (approximately 150g each time),turn the unit on in cooling mode; however, one time is not sufficient, wait approximately 1 minute and then repeat the procedure.
- 5).If the electronic scale displays the proper weight, disconnect the charge hose from the 3-way valve's service port immediately.
If the system has been charged with liquid refrigerant while the air conditioner is on, turn off the air conditioner before disconnecting the hose.
- 6). Mount the valve stem caps and the service port.
Use a torque wrench to tighten the service port cap to a torque of 18N.m.
Be sure to check for gas leakage.

14.5 Drainage pipe installation

Install the drainage pipe as shown below and take measures against condensation. Improperly installation could lead to leakage and eventually wet furniture and belongings.

14.5.1 Installation principle

- Ensure at least 1/100 slope of the drainage pipe
- Adopt suitable pipe diameter
- Adopt nearby condensate water discharge

14.5.2 Key points of drainage water pipe installation

1. Considering the pipeline route and elevation

- Before installing condensate water pipeline, determine its route and elevation to avoid intersection with other pipelines and ensure slope is straight.

2. Drainage pipe selection

- The drainage pipe diameter shall not small than the drain hose of indoor unit
- According to the water flowrate and drainage pipe slope to choose the suitable pipe, the water flowrate is decided by the capacity of indoor unit.

Relationship between water flowrate and capacity of indoor unit

Capacity (x1000Btu)	Water flowrate (l/h)
12	2.4
18	4
24	6
30	7
36	8
42	10
48	12
60	14

According to the above table to calculate the total water flowrate for the confluence pipe selection.

For horizontal drainage pipe (The following table is for reference)

PVC pipe	Reference value of inner diameter of pipe (mm)	Allowable maximum water flowrate (l/h)		Remark
		Slope	Slope	
PVC25	20	39	27	For branch pipe
PVC32	25	70	50	
PVC40	31	125	88	Could be used for confluence pipe
PVC50	40	247	175	
PVC63	51	473	334	

		1/50	1/100	
PVC25	20	39	27	For branch pipe
PVC32	25	70	50	
PVC40	31	125	88	Could be used for confluence pipe
PVC50	40	247	175	
PVC63	51	473	334	

Attention: Adopt PVC40 or bigger pipe to be the main pipe.

For Vertical drainage pipe (The following table is for reference)

PVC pipe	Reference value of inner diameter of pipe (mm)	Allowable maximum water flowrate (l/h)	Remark
PVC25	20	220	For branch pipe
PVC32	25	410	
PVC40	31	730	Could be used for confluence pipe
PVC50	40	1440	
PVC63	51	2760	
PVC75	67	5710	
PVC90	77	8280	

Attention: Adopt PVC40 or bigger pipe to be the main pipe.

3. Individual design of drainage pipe system

- The drainage pipe of air conditioner shall be installed separately with other sewage pipe, rainwater pipe and drainage pipe in building.
- The drainage pipe of the indoor unit with water pump should be apart from the one without water pump.

4. Supporter gap of drainage pipe

- In general, the supporter gap of the drainage pipe horizontal pipe and vertical pipe is respectively 1m~1.5m (3.28~4.92ft) and 1.5m~2.0m(4.95~6.56ft).
- Each vertical pipe shall be equipped with not less than two hangers.
- Overlarge hanger gap for horizontal pipe shall create bending, thus leading to air block.

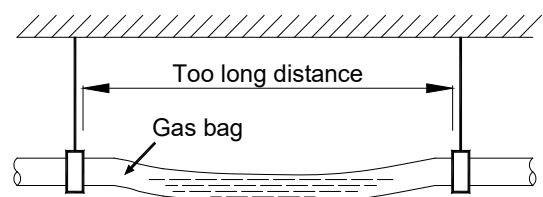

5. The horizontal pipe layout should avoid converse flow or bad flow

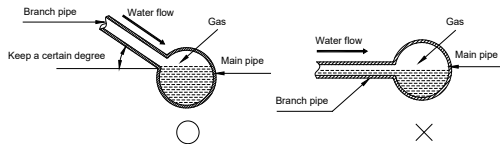
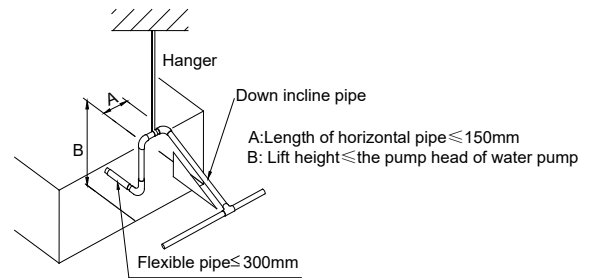
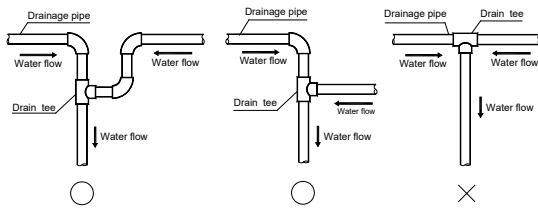

- The correct installation will not cause converse water flow and the slope of the branch pipes can be adjusted freely
- The false installation will cause converse water flow and the slope of the branch pipe cannot be adjusted.

6. Water storage pipe setting

- If the indoor unit has high extra static pressure and without water pump to elevate the condensate water, such as high extra static pressure duct unit, the water storage pipe should be set to avoid converse flow or blow water phenomena.

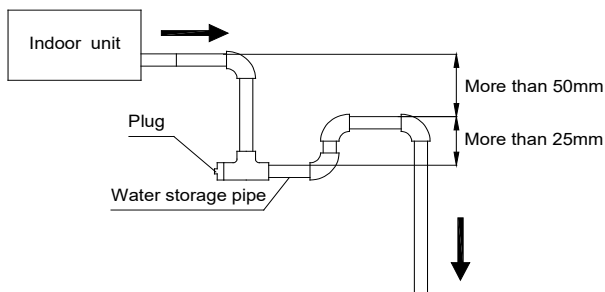

7. Lifting pipe setting of indoor unit with water pump

- The length of lifting pipe should not exceed the pump head of indoor unit water pump.
- The drainage pipe should be set down inclined after the lifting pipe immediately to avoid wrong operation of water level switch.
- Refer the following picture for installation reference.

8. Blowhole setting

- For the concentrated drainage pipe system, there should design a blowhole at the highest point of main pipe to ensure the condensate water discharge smoothly.
- The air outlet shall face down to prevent dirt entering pipe.
- Each indoor unit of the system should be installed it.
- The installation should be considering the convenience for future cleaning.

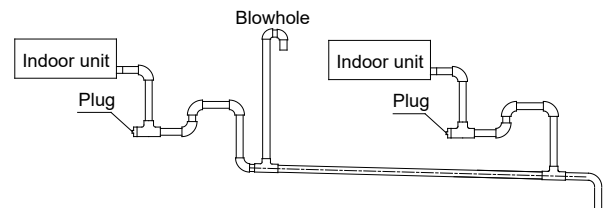

9. The end of drainage pipe shall not contact with ground directly.

14.5.3 Drainage test

14.5.3.1. Water leakage test

After finishing the construction of drainage pipe system, fill the pipe with water and keep it for 24 hours to check whether there is leakage at joint section.

14.5.3.2. Water discharge test

1. Natural drainage mode (the indoor unit with outdoor drainage pump)
 - Infuse above 600ml water through water test hole slowly into the water collector, observe whether the water can discharge through the transparent hard pipe at drainage outlet.

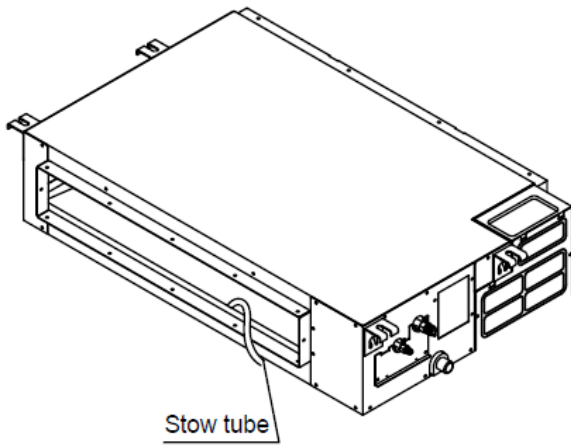

2. Pump drainage mode

2.1 Disconnect the plug of water level switch, remove the cover of water test hole and slowly infuse about 2000ml water through the water test hole, be sure that the water will not touch the motor of drainage pump.

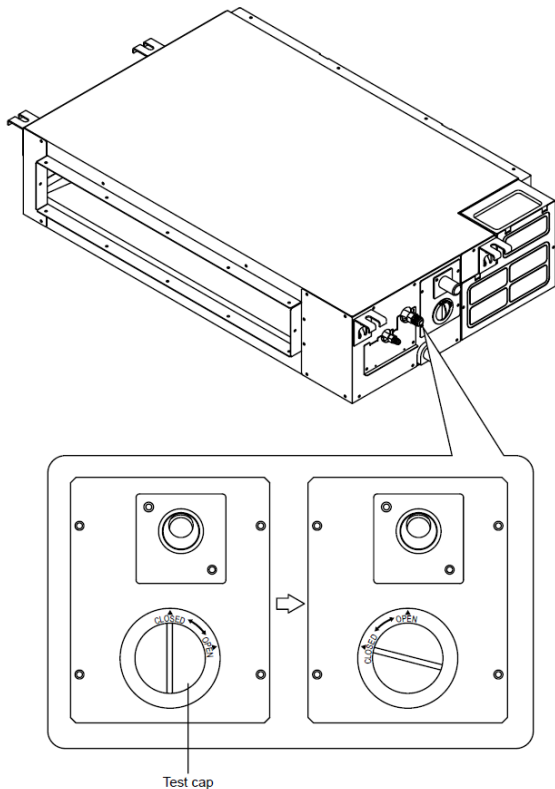

2.2 Power on and let the air conditioner operate for cooling. Check operation status of drainage pump, and then connect the plug of water level switch, check the operation sound of water pump and observe whether the water can discharge through the transparent hard pipe at

drainage outlet. (In light of the length of drainage pipe, water shall be discharged about 1 minute delayed)

- 2.3 Stop the operation of air conditioner, power off the power supply and put the cover of water test hole back to the original place.
- a. After stopped the air conditioner 3 minutes, check whether there is anything abnormal. If drainage pipes have not been distributed properly, over back-flow water shall cause the flashing of alarm indicator at remote-controlled receiving board and even water shall run over the water collector.
 - b. Continuously infusing water until water level alarmed, check whether the drainage pump could discharge water at once. If water level does not decline under warning water level 3 minutes later, it shall cause shutdown of unit. When this situation happens, the normal startup only can be recovered by turning down power supply and eliminating accumulated water.

Note: Drain plug at the main water-containing plate is used for eliminating accumulated water in water-containing plate when maintaining air conditioner fault. During normal operation, the plug shall be filled in to prevent leakage.

14.5.4 Insulation work of drainage pipe
Refer the introduction to the insulation engineering parts.

14.6 Vacuum Drying and Leakage

Checking

14.6.1 Purpose of vacuum drying

- Eliminating moisture in system to prevent the phenomena of ice-blockage and copper oxidation.

Ice-blockage shall cause abnormal operation of system, while copper oxide shall damage compressor.

- Eliminating the non-condensable gas (air) in system to prevent the components oxidizing, pressure fluctuation and bad heat exchange during the operation of system.

14.6.2 Selection of vacuum pump

- The ultimate vacuum degree of vacuum pump shall be -756mmHg or above.
- Precision of vacuum pump shall reach 0.02mmHg or above.

14.6.3 Operation procedure for vacuum drying

Due to different construction environment, two kinds of vacuum drying ways could be chosen, namely ordinary vacuum drying and special vacuum drying.

1 Ordinary vacuum drying

- When conduct first vacuum drying, connect pressure gauge to the infusing mouth of gas pipe and liquid pipe, and keep vacuum pump running for 1hour (vacuum degree of vacuum pump shall be reached -755mmHg).
- If the vacuum degree of vacuum pump could not reach -755mmHg after 1 hour of drying, it indicates that there is moisture or leakage in pipeline system and need to go on with drying for half an hour.
- If the vacuum degree of vacuum pump still could not reach -755mmHg after 1.5 hours of drying, check whether there is leakage source.
- Leakage test: After the vacuum degree reaches -755mmHg, stop vacuum drying and keep the pressure for 1 hour. If the indicator of vacuum gauge does not go up, it is qualified. If going up, it indicates that there is moisture or leak source.

2 Special vacuum drying

The special vacuum drying method shall be adopted when:

- Finding moisture during flushing refrigerant pipe.
- Conducting construction on rainy day, because rain water might penetrated into pipeline.
- Construction period is long, and rain water might penetrated into pipeline.
- Rain water might penetrate into pipeline during construction.

Procedures of special vacuum drying are as follows:

- Vacuum drying for 1 hour.
- Vacuum damage, filling nitrogen to reach 0.5Kgf/cm² .
Because nitrogen is dry gas, vacuum damage could achieve the effect of vacuum drying, but this method could not achieve drying thoroughly when there is too much moisture. Therefore, special attention shall be drawn to prevent the entering of water and the formation of condensate water.
- Vacuum drying again for half an hour.
If the pressure reaches -755mmHg, start to pressure leakage test. If it cannot reach the value, repeat vacuum damage and vacuum drying again for 1 hour.
- Leakage test: After the vacuum degree reaches -755mmHg, stop vacuum drying and keep the pressure for 1 hour. If the indicator of vacuum gauge does not go up, it is qualified. If going up, it indicates that there is moisture or leak source.

14.7 Additional refrigerant charge

- After the vacuum drying process is carried out, the additional refrigerant charge process needs to be performed.
- The outdoor unit is factory charged with refrigerant. The additional refrigerant

charge volume is decided by the diameter and length of the liquid pipe between indoor and outdoor unit. Refer the following formula to calculate the charge volume.

Diameter of liquid pipe (mm)	Φ6.35	Φ9.52
Formula	$V=15g/m \times (L-7.5)$	$V=30g/m \times (L-7.5)$

V: Additional refrigerant charge volume (g).

L: The length of the liquid pipe (m).

Note:

- Refrigerant may only be charged after performed the vacuum drying process.
- Always use gloves and glasses to protect your hands and eyes during the charge work.
- Use electronic scale or fluid infusion apparatus to weight refrigerant to be recharged. Be sure to avoid extra refrigerant charged, it may cause liquid hammer of the compressor or protections.
- Use supplementing flexible pipe to connect refrigerant cylinder, pressure gauge and outdoor unit. And The refrigerant should be charged in liquid state. Before recharging, The air in the flexible pipe and manifold gauge should be exhausted.
- After finished refrigerant recharge process, check whether there is refrigerant leakage at the connection joint part. (Using gas leakage detector or soap water to detect).

14.8 Engineering of insulation

13.8.1 Insulation of refrigerant pipe

1 Operational procedure of refrigerant pipe insulation

Cut the suitable pipe → insulation (except joint section) → flare the pipe → piping layout and connection → vacuum drying → insulate the joint parts

2 Purpose of refrigerant pipe insulation

- During operation, temperature of gas pipe and liquid pipe shall be over-heating or over-cooling extremely. Therefore, it is

necessary to carry out insulation; otherwise it shall debase the performance of unit and burn compressor.

- Gas pipe temperature is very low during cooling. If insulation is not enough, it shall form dew and cause leakage.
- Temperature of gas pipe is very high (generally 50-100 °C) during heating. Insulation work must be carried out to prevent hurt by carelessness touching.

3 Insulation material selection for refrigerant pipe

- The burning performance should over 120°C
- According to the local law to choose insulation materials
- The thickness of insulation layer shall be above 10mm. If in hot or wet environment place, the layer of insulation should be thicker accordingly.

4 Installation highlights of insulation construction

- Gas pipe and liquid pipe shall be insulated separately, if the gas pipe and liquid pipe were insulated together; it will decrease the performance of air conditioner.

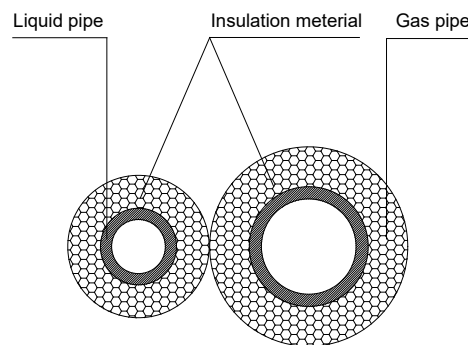

- The insulation material at the joint pipe shall be 5~10cm longer than the gap of the insulation material.
- The insulation material at the joint pipe shall be inserted into the gap of the insulation material.
- The insulation material at the joint pipe shall be banded to the gap pipe and liquid pipe tightly.
- The linking part should be use glue to paste together

- Be sure not bind the insulation material over-tight, it may extrude out the air in the material to cause bad insulation and cause easy aging of the material.

13.8.2 Insulation of drainage pipe

1 Operational procedure of refrigerant pipe insulation

Select the suitable pipe → insulation (except joint section) → piping layout and connection → drainage test → insulate the joint parts

2 Purpose of drainage pipe insulation

The temperature of condensate drainage water is very low. If insulation is not enough, it shall form dew and cause leakage to damage the house decoration.

3 Insulation material selection for drainage pipe

- The insulation material should be flame retardant material, the flame retardancy of the material should be selected according to the local law.
- Thickness of insulation layer is usually above 10mm.
- Use specific glue to paste the seam of insulation material, and then bind with adhesive tape. The width of tape shall not be less than 5cm. Make sure it is firm and avoid dew.

4 Installation and highlights of insulation construction

- The single pipe should be insulated before connecting to another pipe, the joint part should be insulated after the drainage test.
- There should be no insulation gap between the insulation material.

14.9 Engineering of electrical wiring

1 Highlights of electrical wiring installation

- All field wiring construction should be finished by qualified electrician.
- Air conditioning equipment should be grounded according to the local electrical regulations.

- Current leakage protection switch should be installed.
- Do not connect the power wire to the terminal of signal wire.
- When power wire is parallel with signal wire, put wires to their own wire tube and remain at least 300mm gap.
- According to table in indoor part named "the specification of the power" to choose the wiring, make sure the selected wiring not small than the data showing in the table.
- Select different colors for different wire according to relevant regulations.
- Do not use metal wire tube at the place with acid or alkali corrosion, adopt plastic wire tube to replace it.
- There must be not wire connect joint in the wire tube If joint is a must, set a connection box at the place.
- The wiring with different voltage should not be in one wire tube.
- Ensure that the color of the wires of outdoor and the terminal No. are same as those of indoor unit respectively.

14.10 Test operation

1 The test operation must be carried out after the entire installation has been completed.

2 Please confirm the following points before the test operation.

- The indoor unit and outdoor unit are installed properly.
- Tubing and wiring are correctly completed.
- The refrigerant pipe system is leakage-checked.
- The drainage is unimpeded.
- The ground wiring is connected correctly.
- The length of the tubing and the added stow capacity of the refrigerant have been recorded.
- The power voltage fits the rated voltage of the air conditioner.
- There is no obstacle at the outlet and inlet of the outdoor and indoor units.
- The gas-side and liquid-side stop valves are both opened.
- The air conditioner is pre-heated by turning on the power.

3 Test operation

Set the air conditioner under the mode of "COOLING" by remote controller, and check the following points.

Indoor unit

- Whether the switch on the remote controller works well.
- Whether the buttons on the remote controller works well.
- Whether the air flow louver moves normally.
- Whether the room temperature is adjusted well.
- Whether the indicator lights normally.
- Whether the temporary buttons works well.
- Whether the drainage is normal.
- Whether there is vibration or abnormal noise during operation.

Outdoor unit

- Whether there is vibration or abnormal noise during operation.
- Whether the generated wind, noise, or condensed of by the air conditioner have influenced your neighborhood.
- Whether any of the refrigerant is leaked.

15. Operation Characteristics

Temperature Mode	Cooling operation	Heating operation	Drying operation
Room temperature	17°C ~ 32°C(62°F ~ 90°F)	0°C ~ 30°C (32°F ~ 86°F)	10°C ~ 32°C (50°F ~ 90°F)
Outdoor temperature (Entry level)	0°C ~ 50°C (32°F ~ 122°F) (-15°C ~ 50°C(5°F ~ 122°F): For the models with low temperature cooling system)	-15°C ~ 24°C (5°F ~ 75.2°F)	0°C ~ 50°C (32°F ~ 122°F)
Outdoor temperature (E-Star level)	-25°C ~ 50°C(-13°F ~ 122°F)	-25°C ~ 24°C (-13°F ~ 75.2°F)	
Outdoor temperature (Hyper heat)	-30°C ~ 50°C(-22°F ~ 122°F)	-30°C ~ 24°C (-22°F ~ 75.2°F)	

CAUTION:

1. If the air conditioner is used beyond the above conditions, certain safety protection features may come into operation and cause the unit to operate abnormally.
2. The room relative humidity should be less than 80%. If the air conditioner operates beyond this figure, the surface of the air conditioner may attract condensation. Please set the vertical air flow louver to its maximum angle (vertically to the floor), and set HIGH fan mode.
3. The optimum performance will be achieved during this operating temperature zone.

16. Electronic Function

16.1 Abbreviation

- T1: Indoor room temperature
- T2: Coil temperature of indoor heat exchanger
- T3: Coil temperature of condenser
- T4: Outdoor ambient temperature
- T5: Compressor discharge temperature
- Td: Target temperature
- Tsc: Adjusted setting temperature

16.2 Display function

16.2.1 Icon explanation on indoor display board (Duct)

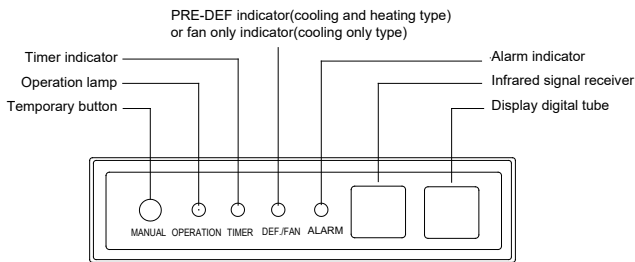

16.2.2 Icon explanation on indoor display board (Compact cassette).

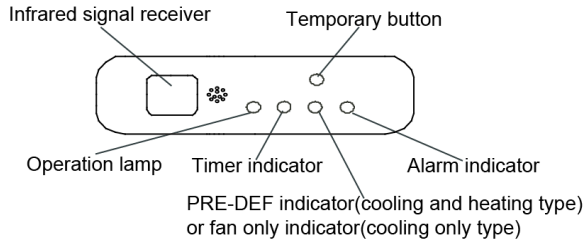

16.2.3 Icon explanation on indoor display board (slim Cassette).

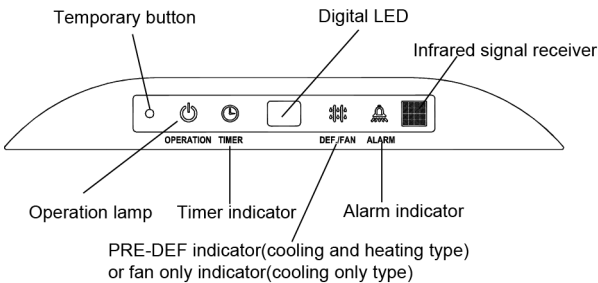

16.2.4 Icon explanation on indoor display board (Console).

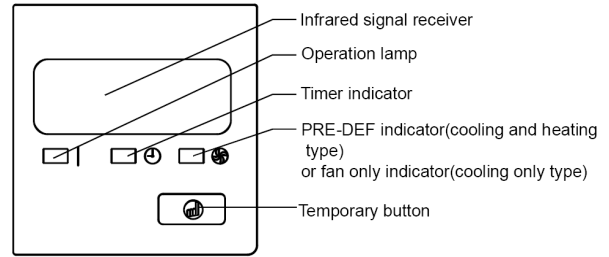

16.2.5 Icon explanation on indoor display board (Ceiling Floor)

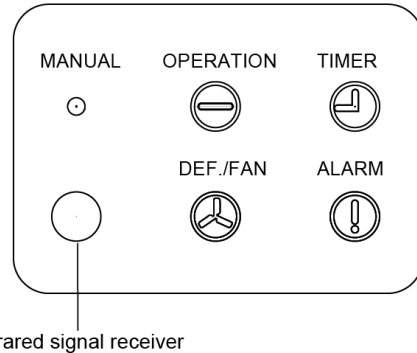

16.2.5 Icon explanation on indoor display board (New Cassette).

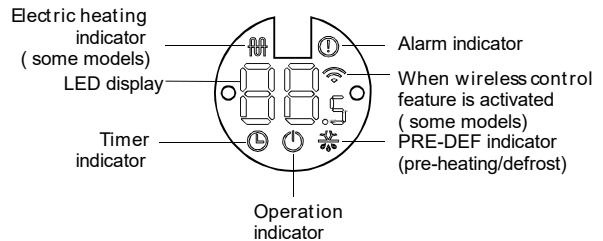

16.3 Main Protection

16.3.1 Three minutes delay at restart for compressor

1 minute delay for the 1st time stand-up and 3 minutes delay for others.

16.3.2 Temperature protection of compressor top

The unit will stop working when the compressor top temp. protector cut off, and will restart after the compressor top temp. protector restart.

16.3.3 Temperature protection of compressor discharge

When the compressor discharge temp. is getting higher, the running frequency will be limited as below rules:

---Compressor discharge temp. $T_5 > 115\text{ }^\circ\text{C}$ (239°F) for 5s, compressor stops and restarts up till $T_5 < 90\text{ }^\circ\text{C}$ (194°F)

--- $110 < T_5 < 115\text{ }^\circ\text{C}$ (239°F), decrease the frequency to the lower level every 2 minutes.

--- $105(221\text{ }^\circ\text{F}) < T_5 < 110\text{ }^\circ\text{C}$ (230°F), keep running at the current frequency.

---- $T_5 < 105\text{ }^\circ\text{C}$ (221°F), no limit for frequency.

16.3.4 Fan speed malfunction

When indoor fan speed keeps too low (lower than 300RPM) for 50s, the indoor fan will shut off and restart 30s later, if protection happened 3 times when fan motor restarts continuously, the unit will stop and the LED will display the failure.

When outdoor fan speed keeps too low (lower than 100RPM) or too high (higher than 1500RPM) for 60s, the unit will stop and the LED will display the failure. Malfunction is cleared 30s later.

For FPA Duct& HESP Duct:

If a fault occurs on the air volume regulator or the regulator enters protection mode, it sends the error message CF and an instruction to reduce fan speed to the master. The message and the instruction can be inquired with the remote controller or the wired controller. (Fault and protection information are displayed for one minute). After a fault occurs, the master unit shows the error code E3 and the fault count for one minute. If the fault occurs three times, then the fan is unable to resolve the problem independently. External shutdown by a remote controller, wired controller, or central controller must be used to clear the fan fault and fault count. The fan runs normally for 5 minutes while clearing fault count.

0: No malfunction
1:P0 Overcurrent
2:Overpressure

3:Overload
4:Overspeed
5:Startup malfunction
6:Lack of phase
7:DC voltage too low
8:Communication fault
9:Parameter fault
10:L3 Current limited
11:L5 Voltage limited
12:Target speed cannot be met during the static pressure calculation process.

16.3.5 Inverter module protection

The Inverter module has a protection function about current, voltage and temperature. If these protections happen, the corresponding code will display on indoor unit and the unit will stop working.

16.3.6 Indoor fan delayed open function

When the unit starts up, the louver will be active immediately and the indoor fan will open 7s later.

If the unit runs in heating mode, the indoor fan will be also controlled by anti-cold wind function.

16.3.7 Compressor preheating functions

Preheating permitting condition:

If $T_4 < 3\text{ }^\circ\text{C}$ (37.4°F)/ $1\text{ }^\circ\text{C}$ (33.8°F)(for 36k~60k models) and the machine connects to power supply newly within 5 seconds or if $T_4 < 3\text{ }^\circ\text{C}$

(37.4°F)/ $1\text{ }^\circ\text{C}$ (33.8°F) (for 36k~60k models)

and compressor has stopped for over 3 hours, the compressor heating cable will work.

Preheating mode:

A weak current flow through the coil of compressor from the wiring terminal of the compressor, then the compressor is heated without operation.

Preheating release condition:

If $T_4 \geq 5^\circ\text{C}$ (41°F) or the compressor starts running, the preheating function will stop.

Only for TIP24,

Preheating permitting condition:

After $T_1 \leq 12^\circ\text{C}$ (53.6°F) condition turns on the outdoor power relay, if $T_4 \leq 1^\circ\text{C}$ (33.8°F) then enter preheating.

Preheating mode:

A weak current flow through the coil of compressor from the wiring terminal of the compressor, then the compressor is heated without operation.

Preheating release condition:

If $T_4 \geq 3^\circ\text{C}$ (37.4°F) or $T_1 > 12^\circ\text{C}$ (53.6°F) for 3 minutes or the compressor starts running, the preheating function will stop.

16.3.8 Condenser high temperature T3 protection

--- 55°C (131°F) $< T_3 < 60^\circ\text{C}$ (140°F), the compressor frequency will decrease to the lower level until to F1 and then runs at F1. If $T_3 < 54^\circ\text{C}$ (129.2°F), the compressor will keep running at the current frequency.

--- $T_3 < 52^\circ\text{C}$ (125.6°F), the compressor will not limit the frequency and resume to the former frequency.

--- $T_3 > 60^\circ\text{C}$ (140°F) for 5 seconds, the compressor will stop until $T_3 < 52^\circ\text{C}$ (125.6°F).

16.3.9 Evaporator low temperature T2 protection

--- $T_2 < 0^\circ\text{C}$ (32°F), the compressor will stop and restart when $T_2 \geq 5^\circ\text{C}$ (41°F).

--- 0°C (32°F) $\leq T_2 < 4^\circ\text{C}$ (39.2°F), the compressor frequency will be limited and decreased to the lower level

--- 4°C (39.2°F) $\leq T_2 \leq 7^\circ\text{C}$ (44.6°F), the compressor will keep the current frequency.

--- $T_2 > 7^\circ\text{C}$ (44.6°F), the compressor frequency will not be limited.

16.4 Operation Modes and Functions

16.4.1 Fan mode

- (1) Outdoor fan and compressor stop.
- (2) Temperature control is disabled and no temperature setting is displayed.
- (3) Indoor fan can be set to 1%~100%, or low, medium, high and auto.
- (4) The louver operates same as in cooling mode.
- (5) Auto fan:

In fan-only mode, AC operates the same as auto fan in cooling mode with the temperature set at 24°C.

16.4.2 Cooling Mode

16.4.2.1 Outdoor fan running rules

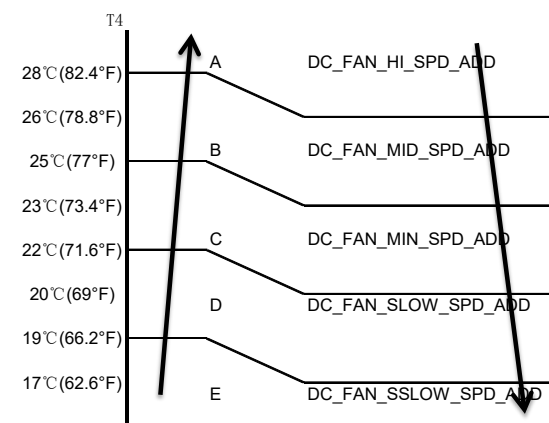

16.4.2.2 Indoor fan running rules

In cooling mode, indoor fan runs all the time and the speed can be selected as 1%~100%, or low, medium, high and auto.

The indoor fan is controlled as below:

Setting fan speed	T1-Td °C(°F)	Actual fan speed
H	4.5(8.1)	H+ (H+=H+G)
	3.0(5.4)	H (=H)
	1.5(2.7)	H- (H-=H-G)
M	4.5(8.1)	M+ (M+=M+Z)
	3.0(5.4)	M (M=M)
	1.5(2.7)	M- (M-=M-Z)
L	4.5(8.1)	L+ (L+=L+D)
	3.0(5.4)	L (L=L)
	1.5(2.7)	L- (L-=L-D)

Auto fan in cooling mode acts as follow:

For TIP

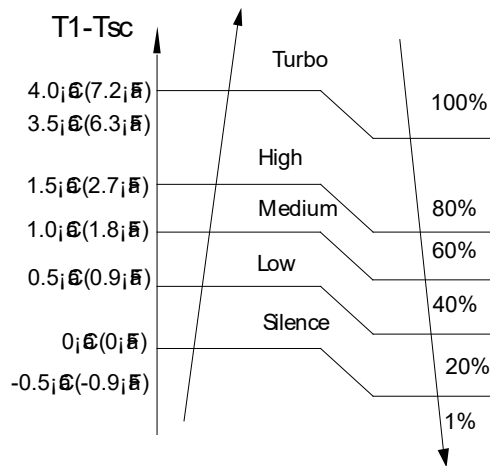

Setting fan speed	$T1-Td+1.5\text{ }^{\circ}\text{C}(34.7\text{ }^{\circ}\text{F})$	Actual fan speed
H	-1.5(-2.7° F)	H-(H=H-G)
	-3.0(-4.8° F)	H (=H)
	-4.5(-8.1° F)	H+(H+=H+G)
M	-1.5(-2.7° F)	M-(M=M-Z)
	-3.0(-4.8° F)	M(M=M)
	-4.5(-8.1° F)	M+(M+=M+Z)
L	-1.5(-2.7° F)	L-(L=L-D)
	-3.0(-4.8° F)	L(L=L)
	-4.5(-8.1° F)	L+(L+=L+D)

Auto fan action in heating mode:

For TIPT0W(GA),

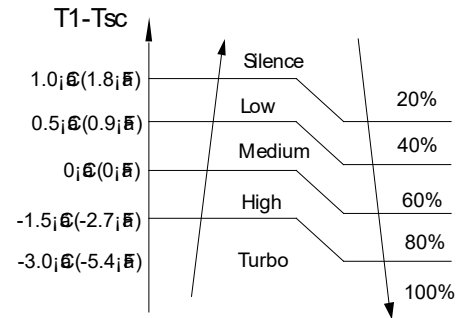

For other models,

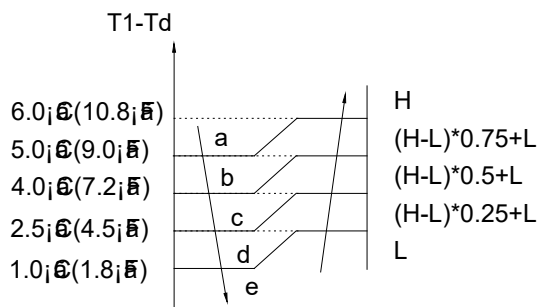

For other models,

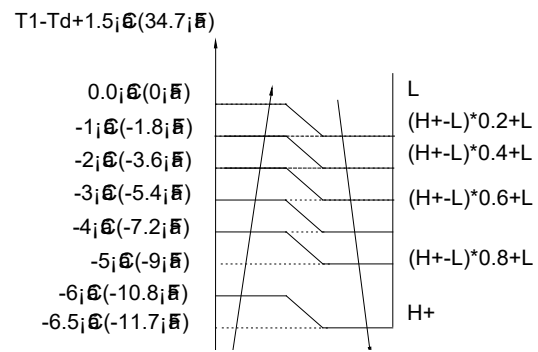

16.4.3 Heating Mode

16.4.3.1 Outdoor fan running rules

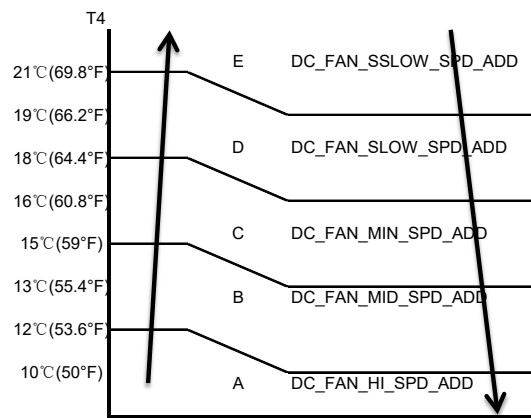

16.4.3.2 Indoor fan running rules

When the compressor is on, the indoor fan can be set to high/med/low/auto. And the anti-cold wind function has the priority.

The indoor fan is controlled as below:

16.4.3.3 Defrosting mode

For

- CZP09CD(O),
- CZP12CD(O),
- CHF09CD(O),
- CHF12CD(O), CHF18CD(O),
- CZP18CD(O),
- CHF24CD(O),
- CZP24CD(O)
- CZP36CD(O)
- CHF36CD(O)
- CZP48CD(O)
- CHF48CD(O)
- CZP60CD(O):

If any one of the following items is satisfied, AC will enter the defrosting mode.

After the compressor starts up and keeps running, mark the minimum value of T3 from the 10th minutes to 15th minutes as T30.

1) If the compressor cumulate running time is up to 29 minutes and $T3 < TCDI1$, $T3 + T30SUBT3ONE < T30$, $T4 > -22^{\circ}C (-7.6^{\circ}F)$.

2) If the compressor cumulate running time is up to 35 minutes and $T3 < TCDI2$, $T3 + T30SUBT3TWO < T30$, $T4 > -22^{\circ}C (-7.6^{\circ}F)$.

3) If the compressor cumulate running time is up to 29 minutes and $T3 < -24^{\circ}C (-11.2^{\circ}F)$, $T4 > -22^{\circ}C (-7.6^{\circ}F)$ for 3 minutes.

4) If the compressor cumulate running time is up to 120 minutes and $T3 < -15^{\circ}C (5^{\circ}F)$, $T4 > -22^{\circ}C (-7.6^{\circ}F)$.

5) If the compressor cumulate running time is up to 30 minutes and $T4 - T3 > (0.5T4 + KDELTT_ADD)$, $T3 < TCDIN5_ADD$, $T4 > -22^{\circ}C (-7.6^{\circ}F)$.

6) If the compressor cumulate running time is up to TIMING_DEFROST_TIME and $T4 \leq -22^{\circ}C (-7.6^{\circ}F)$.

7). If any one of the following conditions is satisfied, the unit enters defrosting mode.

- compressor running time is more than 90 minutes, $Td - T1 < 5^{\circ}C (9^{\circ}F)$ and T3 or T4 is lower than $-3^{\circ}C (26.6^{\circ}F)$ for 30s.
- compressor running time is more than 120 minutes and T3 or T4 is lower than $-3^{\circ}C (26.6^{\circ}F)$ for 30s.

Condition of ending defrosting:

If any one of the following items is satisfied, the defrosting will finish and the machine will turn to normal heating mode.

- T3 rises to be higher than TCDE1.
- T3 keeps to be higher than TCDE2 for 80 seconds.

----The machine has run for 15 minutes in defrosting mode.

If the sixth item is satisfied and any one of the following items is satisfied, the defrosting will finish and the machine will turn to normal heating mode.

----T3 rises to be higher than $10^{\circ}C (50^{\circ}F)$.

---The machine has run for 10 minutes in defrosting mode.

If the seventh item is satisfied and any one of the following items is satisfied, the defrosting will finish and the machine will turn to normal heating mode.

----T3 rises to be higher than $TCDE1 + 4^{\circ}C (39.2^{\circ}F)$.

----T3 keeps to be higher than $TCDE2 + 4^{\circ}C (39.2^{\circ}F)$ for 80 seconds.

----The machine has run for 15 minutes in defrosting mode.

Defrosting action:

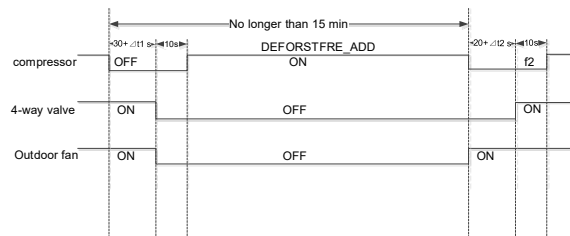

For other outdoor units, If any one of the following items is satisfied, AC will enter the defrosting mode.

After the compressor starts up and keeps running, mark the minimum value of T3 from the 10th minutes to 15th minutes as T30.

1) If the compressor cumulate running time is up to 29 minutes and $T3 < TCDI1$, $T3 + T30SUBT3ONE \leq T30$.

2) If the compressor cumulate running time is up to 35 minutes and $T3 < TCDI2$, $T3 + T30SUBT3TWO \leq T30$.

3) If the compressor cumulate running time is up to 40 minutes and $T3 < TCDI3$ for 3 minutes.

4) If the compressor cumulate running time is up to 30 minutes and $T4 - T3 > (0.5T4 + KDELTT_ADD)$ and $T3 < TCDIN5_ADD$.

Condition of ending defrosting:

If any one of the following items is satisfied, the defrosting will finish and the machine will turn to normal heating mode.

- T3 rises to be higher than TCDE1.
- T3 keeps to be higher than TCDE2 for 80 seconds.
- The machine has run for 10 minutes in defrosting mode.

Defrosting action:

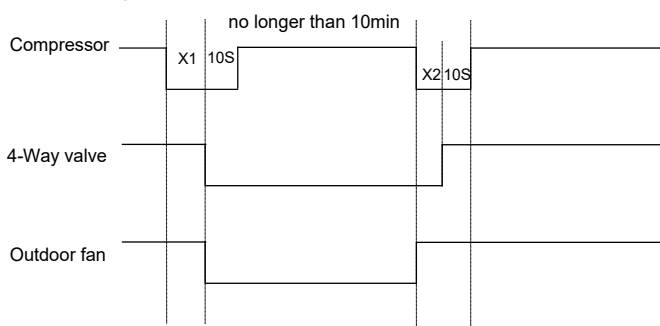

16.4.3.5 Evaporator coil temperature protection

For TIP

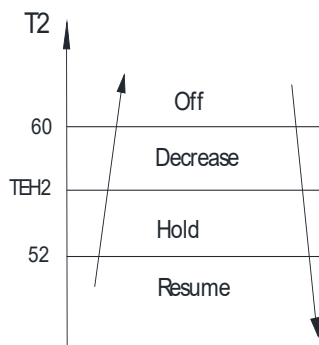

For other models,

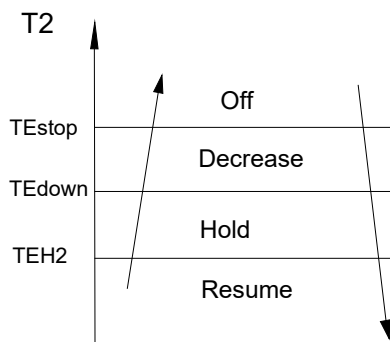

Off: Compressor stops.

Decrease: Decrease the running frequency to the lower level.

Hold: Keep the current frequency.

Resume: No limitation for frequency.

16.4.4 Auto-mode

This mode can be chosen with remote controller and the setting temperature can be changed between 17~30°C(63~86°F).

In auto mode, the machine will choose cooling, heating or fan-only mode according to ΔT ($\Delta T = T1 - Ts$).

$\Delta T = T1 - Ts$	Running mode
$\Delta T > 2^\circ\text{C} (3.6^\circ\text{F})$	Cooling
$-2^\circ\text{C} (-3.6^\circ\text{F}) \leq \Delta T \leq 2^\circ\text{C} (3.6^\circ\text{F})$	Fan-only
$\Delta T < -2^\circ\text{C} (-3.6^\circ\text{F})$	Heating

Indoor fan will run at auto fan of the relevant mode.

The louver operates same as in relevant mode. If the machine switches mode between heating and cooling, the compressor will keep stopping for 15 minutes and then choose mode according to $T1 - Ts$.

If the setting temperature is modified, the machine will choose running function again.

For TIP,

In auto mode, the machine selects cooling, heating or fan-only mode on the basis of $T1, Ts$ and $T4$.

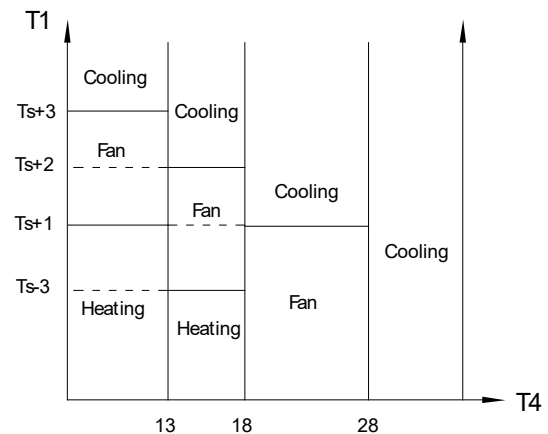

16.4.5 Drying mode

Drying mode works the same as cooling mode in breeze speed.

All protections are active and the same as that in cooling mode.

For TIP,

In drying mode, AC operates the same as auto fan in cooling mode.

All protections are activated and operate the same as they do that in cooling mode.

Low Room Temperature Protection

If the room temperature is lower than 10°C, the compressor ceases operations and does not resume until room temperature exceeds 12°C.

16.4.6 Timer function

16.4.6.1 Timing range is 24 hours.

16.4.6.2 Timer on. The machine will turn on automatically when reaching the setting time.

16.4.6.3 Timer off. The machine will turn off automatically when reaching the setting time.

16.4.6.4 Timer on/off. The machine will turn on automatically when reaching the setting "on" time, and then turn off automatically when reaching the setting "off" time.

16.4.6.5 Timer off/on. The machine will turn off automatically when reaching the setting "off" time, and then turn on automatically when reaching the setting "on" time.

16.4.6.6 The timer function will not change the AC current operation mode. Suppose AC is off now, it will not start up firstly after setting the "timer off" function. And when reaching the setting time, the timer LED will be off and the AC running mode has not been changed.

15.4.6.7 The setting time is relative time.

16.4.7 Sleep function mode

16.4.7.1 The sleep function is available in cooling, heating or auto mode.

16.4.7.2. Operation process in sleep mode is as follow:

When cooling, the setting temperature rises 1°C (1.8°F) (be lower than 30°C(86°F)) every one hour, 2 hours later the setting temperature stops rising and the indoor fan is fixed at low speed.

When heating, the setting temperature decreases 1°C(1.8°F) (be higher than 17°C

(62.6°F)/ 16°C(60.8°F) (TIP) every one hour, 2 hours later the setting temperature stops rising and indoor fan is fixed at low speed. (Anti-cold wind function has the priority).

16.4.7.3 Operation time in sleep mode is 7 hours. After 7 hours, the unit does not switch off, but for console, the unit switches off.

16.4.7.4 Timer setting is available.

16.4.8 Auto-Restart function

The indoor unit is equipped with auto-restart function, which is carried out through an auto-restart module. In case of a sudden power failure, the module memorizes the setting conditions before the power failure. The unit will resume the previous operation setting (not including sleep function) automatically after 3 minutes when power returns.

16.4.9 Follow me

1) If the indoor PCB receives the signal which results from pressing the FOLLOW ME button on remote controller or wired remote controller, the buzzer will emit a sound and this indicates the follow me function is initiated. But when the indoor PCB receives signal which sent from remote controller every 3 minutes, the buzzer will not respond. When the unit is running with follow me function, the PCB will control the unit according to the temperature from follow me signal, and the temperature collection function of room temperature sensor will be shielded.

2) When the follow me function is available, the PCB will control the unit according to the room temperature from the remote controller and the setting temperature.

3) The PCB will take action to the mode change information from remote controller signal, but it will not be affected by the setting temperature.

4) When the unit is running with follow me function, if the PCB doesn't receive any signal from remote controller for 7 minutes or pressing FOLLOW ME button again, the follow me function will be turned off automatically, and the temperature will control the unit according to the room temperature detected from its own

room temperature sensor and setting temperature.

16.4.10 8°C Heating(optional)

In heating operation, the preset temperature of the air conditioner can be as low as 8°C (46.4°F), which keeps the room temperature steady at 8°C(46.4°F) and prevents household things freezing when the house is unoccupied for a long time in severe cold weather.

16.4.11 Drain pump control

Adopt the water-level switch to control the action of drain pump.

Main action under different condition :(every 5 seconds the system will check the water level one time)

1. When the A/C operates with cooling (including auto cooling), dehumidifying, and forced cooling mode, the pump will start running immediately and continuously, till stop cooling.

2. Once the water level increase and up to the control point, LED will alarm and the drain pump open and continue checking the water level. If the water level fall down and LED disarmed (drain pump delay close 1 minute) and operate with the last mode. Otherwise the entire system stop operating (including the pump) and LED remain alarming after 3 minutes,

16.4.12 Electrical energy consumption control function (Optional)

Press the “Gear” button on remote controller to enter the energy efficient mode in a sequence of following:

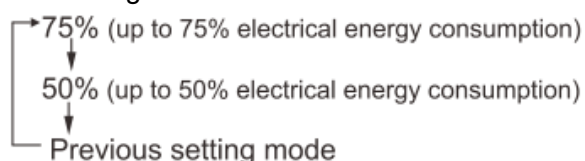

Turn off the unit or activate ECO, sleep, Super cool, 8°C Heating, Silence or self clean function will quit this function.

16.4.13 Silence(Optional)

Press “Silence” or keep pressing Fan button for more than 2 seconds on the remote control to enable the SILENCE function. While this function is active, the compressor frequency is maintained at a lower level than F3. The indoor unit will run at faint breeze(1%), which reduces noise to the lowest possible level.

When match with multi outdoor unit, this function is disabled.

16.4.14 ECO Function(Optional)

Used to enter the energy efficient mode.

Under cooling mode, press ECO button, the remote controller will adjust the temperature automatically to 24°C/75°F, fan speed of Auto to save energy (but only if the set temperature is less than 24°C/75°F).

If the set temperature is more than 24°C/75°F and 30°C/86°F, press the ECO button, the fan speed will change to Auto, the set temperature will remain unchanged.

When pressing the ECO button, or modifying the mode or adjusting the set temperature to less than 24°C/75°F, the AC will quit the ECO operation.

Operation time in ECO mode is 8 hours. After 8 hours the AC quits this mode.

16.4.15 Breeze Away function (for some models)

This feature avoids direct airflow blowing on the body and makes you feel indulging in silky coolness.

• NOTE: This feature is available under cooling mode, fan-only mode and drying mode.

16.4.16 Active Clean function

The Active Clean Technology washes away dust, mold, and grease that may cause odors when it adheres to the heat exchanger by automatically freezing and then rapidly thawing the frost. The internal wind wheel then keeps operating to blow-dry the evaporator, thus preventing the growth of mold and keeping the inside clean.

• When this function is turned on, the indoor unit display window appears “CL”, after 20 to 45

minutes, the unit will turn off automatically and cancel Active Clean function.

16.4.12 Point check function

Press the LED DISPLAY or LED or MUTE button of the remote controller three times, and then press the AIR DIRECTION or SWING button three times in ten seconds, the buzzer will keep ring for two seconds. The air conditioner will enter into the information enquiry status. You can press the LED DISPLAY or AIR DIRECTION button to check the next or front item's information.

When the AC enter the "information enquiry" status, it will display the code name in 2 seconds, the details are as follows.

Enquiry information	Displaying code	Meaning
T1	T1	T1 temp.
T2	T2	T2 temp.
T3	T3	T3 temp.
T4	T4	T4 temp.
T2B	Tb	T2B temp.
T5	T5	T5 temp.
TH	TH	TH temp.
Targeted Frequency	FT	Targeted Frequency
Actual Frequency	Fr	Actual Frequency
Indoor fan speed	IF	Indoor fan speed
Outdoor fan speed	OF	Outdoor fan speed
EXV opening angle	LA	EXV opening angle
Compressor continuous running time	CT	Compressor continuous running time
Causes of compressor stop.	ST	Causes of compressor stop.
Reserve	A0	
Reserve	A1	
Reserve	b0	
Reserve	b1	
Reserve	b2	
Reserve	b3	
Reserve	b4	
Reserve	b5	
Reserve	b6	
Reserve	dL	
Reserve	Ac	
Reserve	Uo	
Reserve	Td	

When the AC enter into the information enquiry status, it will display the code value in the next 25s, the details are as follows.

Enquiry information	Display value	Meaning	Remark
T1,T2,T3,T4, T2B,T5,TH, Targeted Frequency, Actual Frequency	-1F,-1E,-1d,-1c,- 1b,-1A	-25,-24,-23,-22,-21,-2 0	1. All the displaying temperature is actual value. 2. All the temperature is °C no matter what kind of remote controller is used. 3. T1,T2,T3,T4,T2B display range:-25~70, T5 display range:-20~130. 4. Frequency display range: 0~159HZ. 5. If the actual value exceeds the range, it will display the maximum value or minimum value.
	-19—99	-19—99	
	A0,A1,...A9	100,101,...109	
	b0,b1,...b9	110,111,...119	
	c0,c1,...c9	120,121,...129	
	d0,d1,...d9	130,131,...139	
	E0,E1,...E9	140,141,...149	
	F0,F1,...F9	150,151,...159	
Indoor fan speed /Outdoor fan speed	0	OFF	
	1,2,3,4	Low speed, Medium speed, High speed, Turbo	For some big capacity motors.
	14-FF	Actual fan speed=Display value turns to decimal value and then multiply 10. The unit is RPM.	For some small capacity motors, display value is from 14-FF(hexadecimal), the corresponding fan speed range is from 200-2550RPM.
EXV opening angle	0-FF	Actual EXV opening value=Display value turns to decimal value and then multiply 2.	
Compressor continuous running time	0-FF	0-255 minutes	If the actual value exceeds the range, it will display the maximum value or minimum value.
Causes of compressor stop.	0-99	For the detailed meaning, please consult with engineer	Decimal display
Reserve	0-FF		

For TIP,

- To enter engineer mode, in power-on or standby mode, and in non-locked state, press the key combination “ON/OFF + Air Speed” for 7s:
- After entering the engineer mode, the remote control will display icons of “Auto, Cool, Dry, Heat”, and the Battery icon; at the same time, it will also display the numeric code of the current engineer mode (for the initial engineer mode, the numeric code displayed is 0), and all other icons are inactive.
- In engineer mode, the value of the current numeric code can be adjusted circularly through the Up/Down key, with the setting range of 0 to 30.

Code	Query Content	Additional Notes
0	Error code	Refer to next list of error code
1	Room temperature	T1 temperature
2	Indoor coil temperature	T2 temperature
3	Outdoor coil temperature	T3 temperature
4	Ambient temperature	T4 temperature
5	Discharge temperature	TP temperature
6	Compressor Target Frequency FT	Targeted Frequency
7	Compressor Running Frequency Fr	Actual Frequency
8	Current dL	N/A
9	Current AC Voltage Uo	N/A
10	Current indoor capacity test state Sn	N/A
11	Runing mode od	
12	Set Speed Pr of the outdoor fan	Outdoor fan speed=value*8
13	Opening Lr of EEV	EXV opening angle-value*8
14	Actual Running Speed ir of the indoor fan	Indoor fan speed=value*8
15	Indoor Humidity Hu	N/A
16	Set Temperature TT after compensation	N/A
17		N/A
18		N/A
19	/	N/A
20	Indoor Target Frequency oT	N/A
21	Reserve	
22		
23		
24		
25		
26		
27		
28		
29		
30		

In Channel 1~30 settings of the engineer mode, long press the On/off key to return the previous engineer mode.

Exit of engineer mode:

- 1)In engineer mode, press the key combination of “On/Off + Air speed” for 2s;
- 2)The engineer mode will be exited if there are no valid key operations for continuous 60s.

Error code of engineer mode

Display	Error Information
EH 00/ EH 0A	Indoor unit EEPROM parameter error
EL 01	Indoor / outdoor unit communication error
EH bA	Communication error between indoor unit and indoor external fan module
EH 30	Parameters error of indoor external fan
EH 35	Phase failure of indoor external fan
EH 36	Indoor external fan current sampling bias fault
EH 37	Indoor external fan zero speed failure
EH 38	Indoor external fan stall failure
EH 39	Out of step failure of indoor external fan
EH 3A	Low voltage protection of indoor external fan DC bus
EH 3b	Indoor external fan DC bus voltage is too high fault
EH 3E	Indoor external fan overcurrent fault
EH 3F	Indoor external fan module protection/hardware Current overload protection
EH 03	The indoor fan speed is operating outside of the normal range
EC 51	Outdoor unit EEPROM parameter error
EC 52	Condenser coil temperature sensor T3 is in open circuit or has short circuited
EC 53	Outdoor room temperature sensor T4 is in open circuit or has short circuited
EC 54	Compressor discharge temperature sensor TP is in open circuit or has short circuited
EC 55	IGBT temperature sensor TH is in open circuit or has short circuited
EC 0d	Outdoor unit malfunction
Eh 60	Indoor room temperature sensor T1 is in open circuit or has short circuited
Eh 61	Evaporator coil temperature sensor T2 is in open circuit or has short circuited
EC 71	Outdoor external fan overcurrent fault
EC 75	Outdoor external fan module protection/hardware Current overload protection
EC 72	Outdoor external fan phase failure
EC 74	Outdoor external fan current sampling bias fault
EC 73	Zero speed failure of outdoor unit DC fan
EC 07	The outdoor fan speed is operating outside of the normal range(
EL 0C	Refrigerant leak detected
EH 0E	Water-level alarm malfunction
PC 00	IPM malfunction or IGBT over-strong current protection
PC 10	Over low voltage protection
PC 11	Over voltage protection
PC 12	DC voltage protection
pc 02	Top temperature protection of compressor or High temperature protection of IPM module
PC 40	Communication error between outdoor main chip and compressor driven chip
PC 41	Current Input detection protection
PC 42	Compressor start error
PC 43	Lack of phase (3 phase) protection
PC 44	No speed protection
PC 45	341PWM error

PC 46	Compressor speed malfunction
PC 49	Compressor over current protection
PC 06	Compressor discharge temperature protection
PC 08	Outdoor current protection
PH 09	Anti-cold air in heating mode
pc 0f	PFC module malfunction
pc 30	System overpressure protection
pc 31	System pressure is too low protection
PC 03	Pressure protection
pc 0l	Outdoor low ambient temperature protection
PH 90	Evaporator coil temperature over high protection
PH 91	Evaporator coil temperature over low Protection
PC 0A	Condenser high temperature protection
PH 0c	Indoor unit humidity sensor failure
LH 00	Frequency limit caused by T2
lh 30	Indoor external fan current limit
lh 31	Indoor external fan voltage limit
LC 01	Frequency limit caused by T3
LC 02	Frequency limit caused by TP
LC 05	Frequency limit caused by voltage
LC 03	Frequency limit caused by current
LC 06	Frequency limit caused by PFC
LC 30	Frequency limit caused by high pressure
LC 31	Frequency limit caused by low pressure
LH 07	Frequency limit caused by remote controller
--	Indoor units mode conflict(match with multi outdoor unit)

17. Troubleshooting

Safety

Electricity is stored in capacitors, even when the power supply is shut off. Do not forget to discharge the electricity in the capacitors.

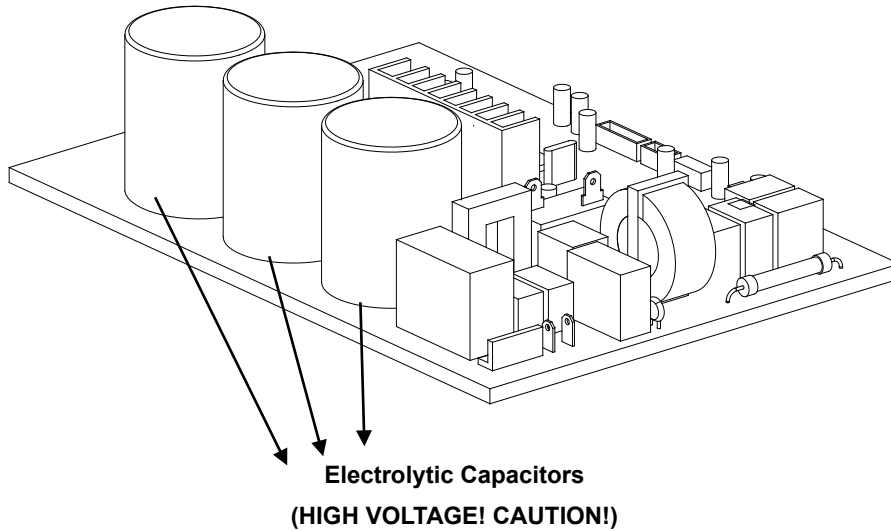

For other models, For other models, connect a discharge resistor (approx.100Ω 40W) or a soldering iron plug between the + and - terminals of the electrolytic capacitor on the opposite side of the outdoor printed circuit board (PCB).

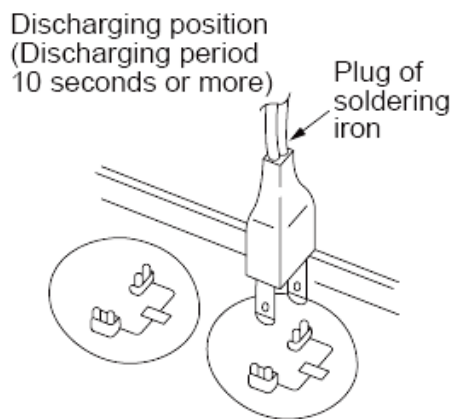

Note: The picture above is for reference purposes only. The design of the devices depicted may vary by model.

17.1 Indoor Unit Error Display

Operation lamp	Timer lamp	Display	LED STATUS
☆ 1 time	X	E0	Indoor unit EEPROM parameter error
☆ 2 times	X	E1	Communication malfunction between indoor and outdoor units
☆ 4 times	X	E3	Indoor fan speed malfunction
☆ 5 times	X	E4	Indoor room temperature sensor (T1) malfunction
☆ 6 times	X	E5	Evaporator coil temperature sensor (T2) malfunction
☆ 7 times	X	EC	Refrigerant leakage detection
☆ 8 times	X	EE	Water-level alarm malfunction
☆ 1 time	O	F0	Current overload protection
☆ 2 times	O	F1	Outdoor ambient temperature sensor (T4) malfunction
☆ 3 times	O	F2	Condenser coil temperature sensor (T3) malfunction
☆ 4 times	O	F3	Compressor discharge temperature sensor (T5) malfunction
☆ 5 times	O	F4	Outdoor unit EEPROM parameter error
☆ 6 times	O	F5	Outdoor fan speed malfunction
☆ 8 times	O	F7	Communication malfunction between indoor unit and auto-lifting panel
☆ 9 times	O	F8	Auto-lifting panel malfunction
☆ 10 times	O	F9	Auto-lifting panel malfunction is not closed
☆ 11 times	O	FA	Communication malfunction between indoor two chips(For FPA Duct)
☆ 1 times	☆	P0	Inverter module (IPM) malfunction
☆ 2 times	☆	P1	Over-voltage or under-voltage protection
☆ 3 times	☆	P2	Compressor top high temperature protection (OLP)/ High temperature protection of IPM board
☆ 4 times	☆	P3	Low ambient temperature cut off in heating
☆ 5 times	☆	P4	Compressor drive malfunction
☆ 6 times	☆	P5	Indoor units mode conflict
☆ 7 times	☆	P6	High pressure protection or low pressure protection (for some models)
☆ 8 times	☆	P7	Outdoor IPM temperature sensor error

O (light)

X (off)

☆ (flash)

TIP24, TIP36, TIP48

Operation Lamp	Timer Lamp	Display	Error Information
1 time	OFF	EH 00/EH 0A	Indoor unit EEPROM parameter error
2 times	OFF	EL 01	Indoor / outdoor unit communication error
4 times	OFF	EH 03	The indoor fan speed is operating outside of the normal range(for some models)
6 times	OFF	EH 60	Indoor room temperature sensor T1 is in open circuit or has short circuited
6 times	OFF	EH 61	Evaporator coil temperature sensor T2 is in open circuit or has short circuited
8 times	OFF	EL 0C	Refrigerant Leakage Detection(for some models)
13 times	OFF	EH 0E	Water-level alarm malfunction
5 times	OFF	EC 53	Outdoor room temperature sensor T4 is in open circuit or has short circuited
5 times	OFF	EC 52	Condenser coil temperature sensor T3 is in open circuit or has short circuited
5 times	OFF	EC 54	Compressor discharge temperature sensor TP is in open circuit or has short circuited
5 times	OFF	EC 56	Evaporator coil outlet temperature sensor T2B is in open circuit or has short circuited(for free-match indoor units)
5 times	ON	EC 51	Outdoor unit EEPROM parameter error
12 times	OFF	EC 07	The outdoor fan speed is operating outside of the normal range(for some models)
7 times	FLASH	PC 00	IPM malfunction or IGBT over-strong current protection
2 times	FLASH	PC 01	Over voltage or over low voltage protection
3 times	FLASH	PC 02	Top temperature protection of compressor or High temperature protection of IPM module
5 times	FLASH	PC 04	Inverter compressor drive error
7 times	FLASH	PC 03	High pressure protection or low pressure protection (for some models)
14 times	OFF	EC 0d	Outdoor unit malfunction
1 time	ON	--	Indoor units mode conflict(match with multi outdoor unit)

17.2 Error Display on Two Way Communication Wired Controller

Display	LED STATUS
F0	Communication error between wired controller and indoor unit
F1	The cassette panel is abnormal
E1	Communication malfunction between indoor and outdoor units
E2	Indoor room temperature sensor (T1) is in open circuit or has short circuited
E3	Evaporator coil temperature sensor (T2) is in open circuit or has short circuited
E4	Evaporator coil outlet temperature sensor T2B is in open circuit or has short circuited(for free-match units)
E5	Outdoor ambient temperature sensor (T4) or condenser coil temperature sensor (T3) or compressor discharge temperature sensor (T5) is in open circuit or has short circuited
E7	Indoor unit EEPROM parameter error
E8	Indoor fan speed is operating outside of the normal range
EA	Current overload protection
Eb	Inverter module (IPM) malfunction
Ed	Outdoor unit malfunction
EE	Water-level alarm malfunction
EF	Other malfunction

For new cassette type, error display on two way communication wired controller is the same as that of indoor display.

17.3 Outdoor unit error display For 9K-24K outdoor unit:

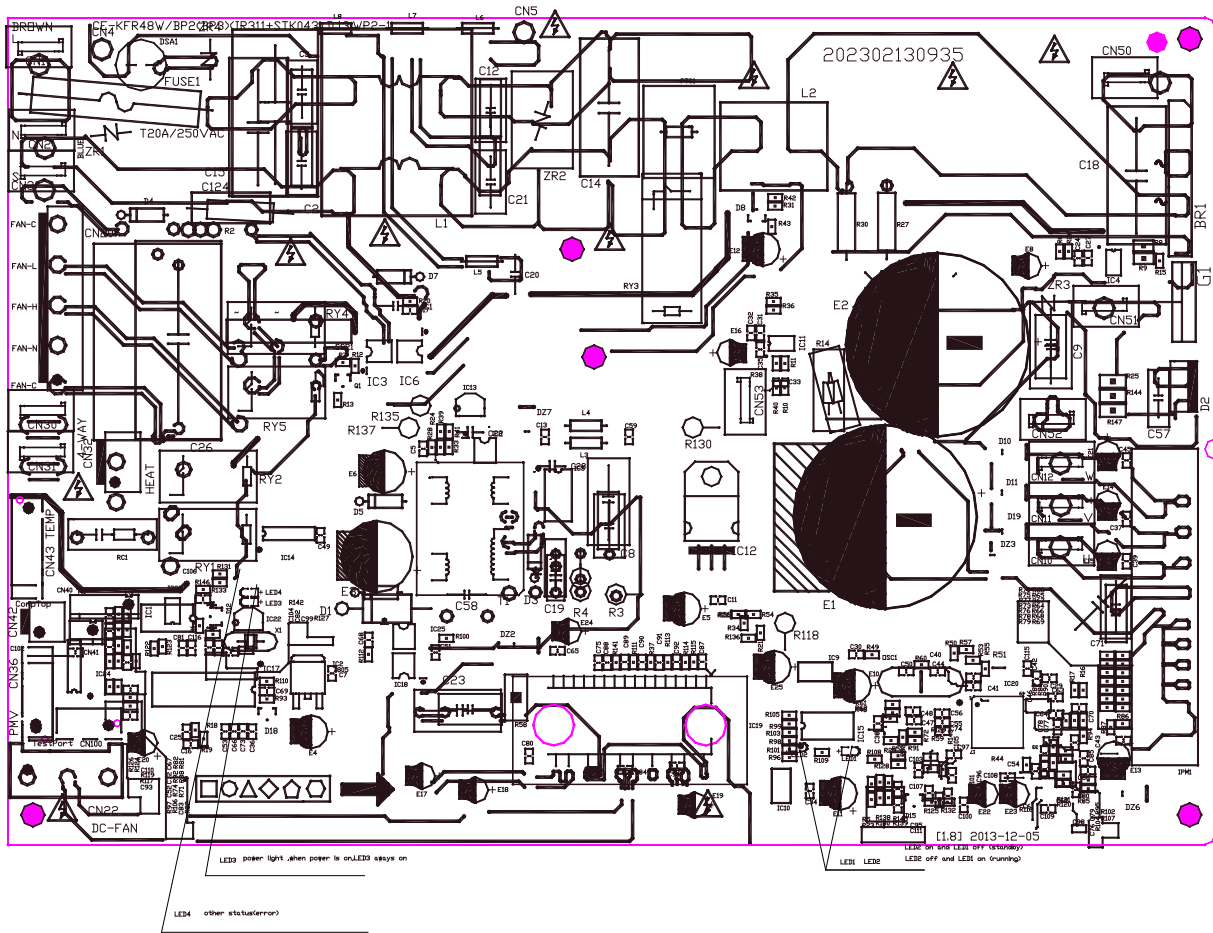

No.	Problems	LED2 (Green)	LED1 (Red)	IU display
1	standby for normal	O	X	
2	Operation normally	X	O	
3	Compressor drive board EEPROM error	O	☆	E5
4	IPM malfunction or IGBT over-strong current protection	☆	X	P0
5	Over voltage or too low voltage protection	O	O	P1
6	Inverter compressor drive error	X	☆	P4
7	Inverter compressor drive error	☆	O	P4
8	Communication malfunction between main control board and driver board	☆	☆	P4

**For CZP36CD(O), CHF36CD(O), CZP48CD(O),
CHF48CD(O), CZP60CD(O)**

Display	LED STATUS
EC 51	Outdoor EEPROM malfunction
EL 01	Indoor / outdoor units communication error
PC 40	Communication malfunction between IPM board and outdoor main board
PC 08	Outdoor overcurrent protection
PC 10	Outdoor unit low AC voltage protection
PC 11	Outdoor unit main control board DC bus high voltage protection
PC 12	Outdoor unit main control board DC bus high voltage protection /341 MCE error
PC 00	IPM module protection
PC 0F	PFC module protection
EC 71	Over current failure of outdoor DC fan motor
EC 72	Lack phase failure of outdoor DC fan motor
EC 07	Outdoor fan speed has been out of control
PC 43	Outdoor compressor lack phase protection
PC 44	Outdoor unit zero speed protection
PC 45	Outdoor unit IR chip drive failure
PC 46	Compressor speed has been out of control
PC 49	Compressor overcurrent failure
PC 30	High pressure protection
PC 31	Low pressure protection
PC 0A	High temperature protection of condenser
PC 06	Temperature protection of compressor discharge
PC 0L	Low ambient temperature protection
PC 02	Top temperature protection of compressor
EC 52	Condenser coil temperature sensor T3 is in open circuit or has short circuited
EC 53	Outdoor room temperature sensor T4 is in open circuit or has short circuited
EC 54	Compressor discharge temperature sensor TP is in open circuit or has short circuited
EC 55	Outdoor IPM module temperature sensor malfunction

**For 36K-60K Outdoor Unit(excluding CZP36CD(O), CHF36CD(O), CZP48CD(O),CHF48CD(O),
CZP60CD(O))**

No	Problems	Error Code
1	Communication malfunction between indoor and outdoor units	E1
2	Current overload protection	F0
3	Outdoor ambient temperature sensor (T4) malfunction	F1
4	Condenser coil temperature sensor (T3) malfunction	F2
5	Compressor discharge temperature sensor (T5) malfunction	F3
6	Outdoor unit EEPROM parameter error	F4
7	Outdoor fan speed malfunction	F5
8	Inverter module (IPM) malfunction	P0
9	Over-voltage or under-voltage protection	P1

10	Compressor top high temperature protection (OLP)	P2
11	Low ambient temperature cut off in heating	P3
12	Compressor drive malfunction	P4
13	High temperature protection of indoor coil in heating	J0
14	Outdoor temperature protection of outdoor coil in cooling	J1
15	Temperature protection of compressor discharge	J2
16	PFC module protection	J3
17	Communication malfunction between control board and IPM board	J4
18	High pressure protection	J5
19	Low pressure protection	J6
20	Outdoor IPM module temperature sensor malfunction	P7
21	AC voltage protection	J8

Outdoor check function

N	Display	Remark
00	Normal display	Display running frequency, running state or malfunction code
01	Indoor unit capacity demand code	Actual data*HP*10 If capacity demand code is higher than 99, the digital display tube will show single digit and tens digit. (For example, the digital display tube show "5.0",it means the capacity demand is 15. the digital display tube show "60",it means the capacity demand is 6.0)
02	Amendatory capacity demand code	
03	The frequency after the capacity requirement transfer	
04	The frequency after the frequency limit	
05	The frequency of sending to 341 chip	
06	Indoor unit evaporator temperature	If the temp. is lower than 0 degree, the digital display tube will show "0".If the temp. is higher than 70 degree, the digital display tube will show "70".
07	Condenser pipe temp.(T3)	If the temp. is lower than -9 degree, the digital display tube will show "-9".If the temp. is higher than 70 degree, the digital display tube will show "70". If the indoor unit is not connected, the digital display tube will show: "——"
08	Outdoor ambient temp.(T4)	
09	Compressor discharge temp.(T5)	The display value is between 13~129 degree. If the temp. is lower than 13 degree, the digital display tube will show "13".If the temp. is higher than 99 degree, the digital display tube will show single digit and tens digit. (For example, the digital display tube show "0.5",it means the compressor discharge temp. is 105 degree. the digital display tube show "1.6",it means the compressor discharge temp. is 116 degree)
10	AD value of current	The display value is hex number.

11	AD value of voltage			
12	Indoor unit running mode code	Standby:0, Fan only: 1,Cooling:2, Heating:3, Forced cooling:4, Drying:6, Self clean:8, Forced defrosting:10		
13	Outdoor unit running mode code	Standby:0, Fan only: 1,Cooling:2, Heating:3, Forced cooling:4, Drying:6, Self clean:8, Forced defrosting:10		
14	EXV open angle	Actual data/4. If the value is higher than 99, the digital display tube will show single digit and tens digit. For example, the digital display tube show "2.0",it means the EXV open angle is 120×4=480p.)		
15	Frequency limit symbol	Bit7	Frequency limit caused by IGBT radiator	The display value is hex number. For example, the digital display tube show 2A, then Bit5=1, Bit3=1, Bit1=1. It means frequency limit caused by T4, T3 and current.
		Bit6	Frequency limit caused by PFC	
		Bit5	Frequency limit caused by high temperature of T2.	
		Bit4	Frequency limit caused by low temperature of T2.	
		Bit3	Frequency limit caused by T3.	
		Bit2	Frequency limit caused by T5.	
		Bit1	Frequency limit caused by current	
		Bit0	Frequency limit caused by voltage	
16	DC fan motor speed	0:off 1:Turbo 2:High 3:Medium 4:Low 5: Breeze 6:Super Breeze 7:other fan speed(other 36k~60k models) 0:off 1:High 2:Medium 3:Low 4: Breeze 21:Turbo 30~34: Low temperature cooling 5~1 gear, corresponding gear value conversion hexadecimal display (for CHF36CD(O), CZP48CD(O), CHF48CD(O), CZP60CD(O))		
17	IGBT radiator temp.	The display value is between 0~130 degree. If the temp. is lower than 30 degree, the digital display tube will show "30".If the temp. is higher than 99 degree, the digital display tube will show single digit and tens digit. (For example, the digital display tube show "0.5",it means the IGBT radiator temp. is 105 degree. the digital display tube show "1.6",it means the IGBT radiator temp. is 116 degree)		
18	Indoor unit number	The indoor unit can communicate with outdoor unit well. General:1, Twins:2		
19	Evaporator pipe temp. T2 of 1# indoor unit	If the temp. is lower than 0 degree, the digital display tube will show "0".If the temp. is higher than 70 degree, the digital display tube will show "70". If the indoor unit is not connected, the digital display tube will show: "____"		
20	Evaporator pipe temp. T2 of 2# indoor unit			
21	Evaporator pipe temp. T2 of 3# indoor unit			
22	1# Indoor unit capacity demand code	Actual data*HP*10 If capacity demand code is higher than 99, the digital display		

23	2# Indoor unit capacity demand code	tube will show single digit and tens digit. (For example, the digital display tube show "5.0",it means the capacity demand is 15. the digital display tube show "60",it means the capacity demand is 6.0). If the indoor unit is not connected, the digital display tube will show: "——"
24	3# Indoor unit capacity demand code	
25	Room temp. T1 of 1# indoor unit	If the temp. is lower than 0 degree, the digital display tube will show "0".If the temp. is higher than 70 degree, the digital display tube will show "70". If the indoor unit is not connected, the digital display tube will show: "——"
26	Room temp. T1 of 2# indoor unit	
27	Average room temp. T1	
28	Reason of stop	
29	Evaporator pipe temp. T2B of 1# indoor unit	If the temp. is lower than 0 degree, the digital display tube will show "0".If the temp. is higher than 70 degree, the digital display tube will show "70". If the indoor unit is not connected, the digital display tube will show: "——"
30	Evaporator pipe temp. T2B of 2# indoor unit	
31	EVI valve open angle(only for CHF36CD(O) CHF48CD(O))	Actual data/4. If the value is higher than 99, the digital display tube will show single digit and tens digit. For example, the digital display tube show "2.0",it means the EXV open angle is $120 \times 4 = 480p.$)

17.4 Diagnosis and Solution

17.4.1 EEPROM parameter error diagnosis and solution

Error Code	E0/ EH 00/EH 0A/F4/ EC 51
Malfunction conditions	Indoor or outdoor PCB main chip does not receive feedback from EEPROM chip.
Potential causes	<ul style="list-style-type: none">● Installation mistake● Faulty PCB

Trouble shooting:

Power off, then restart the unit 2 minutes later. Does a problem still remain?

Yes

Replace the indoor/outdoor main PCB.

EEPROM: a type of read-only memory. The contents can be erased and reprogrammed using a pulsed voltage. To locate the EEPROM chip,

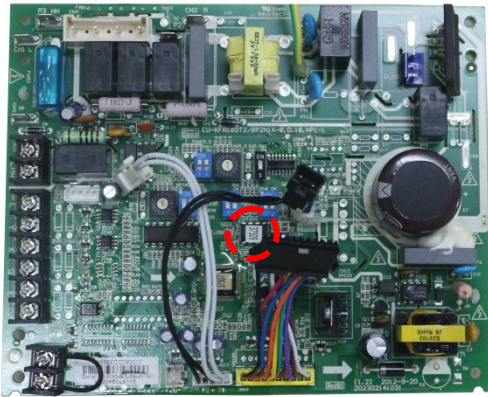

Indoor PCB

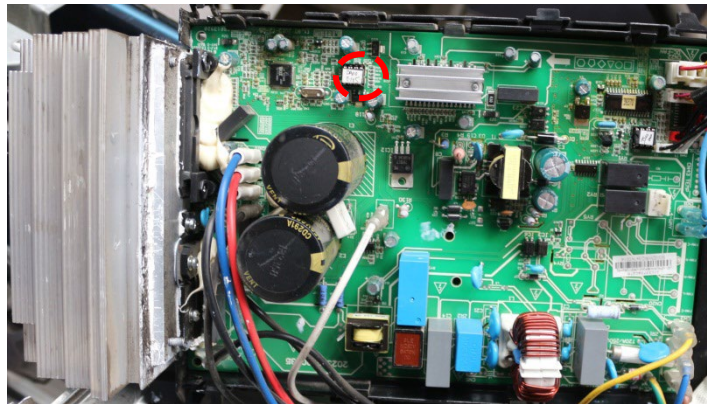

Outdoor PCB

Note: The two photos above are only for reference purposes only. The design of the devices depicted may vary by model.

17.4.2 Communication malfunction between indoor and outdoor units diagnosis and solution (E1)

For 9K-24K:

Error Code	E1/ EL 01
Malfunction conditions	If the indoor unit does not receive feedback from outdoor unit for 110 seconds 4 consecutive times.
Potential causes	<ul style="list-style-type: none">● Wiring mistake● Faulty indoor or outdoor PCB

Trouble shooting:

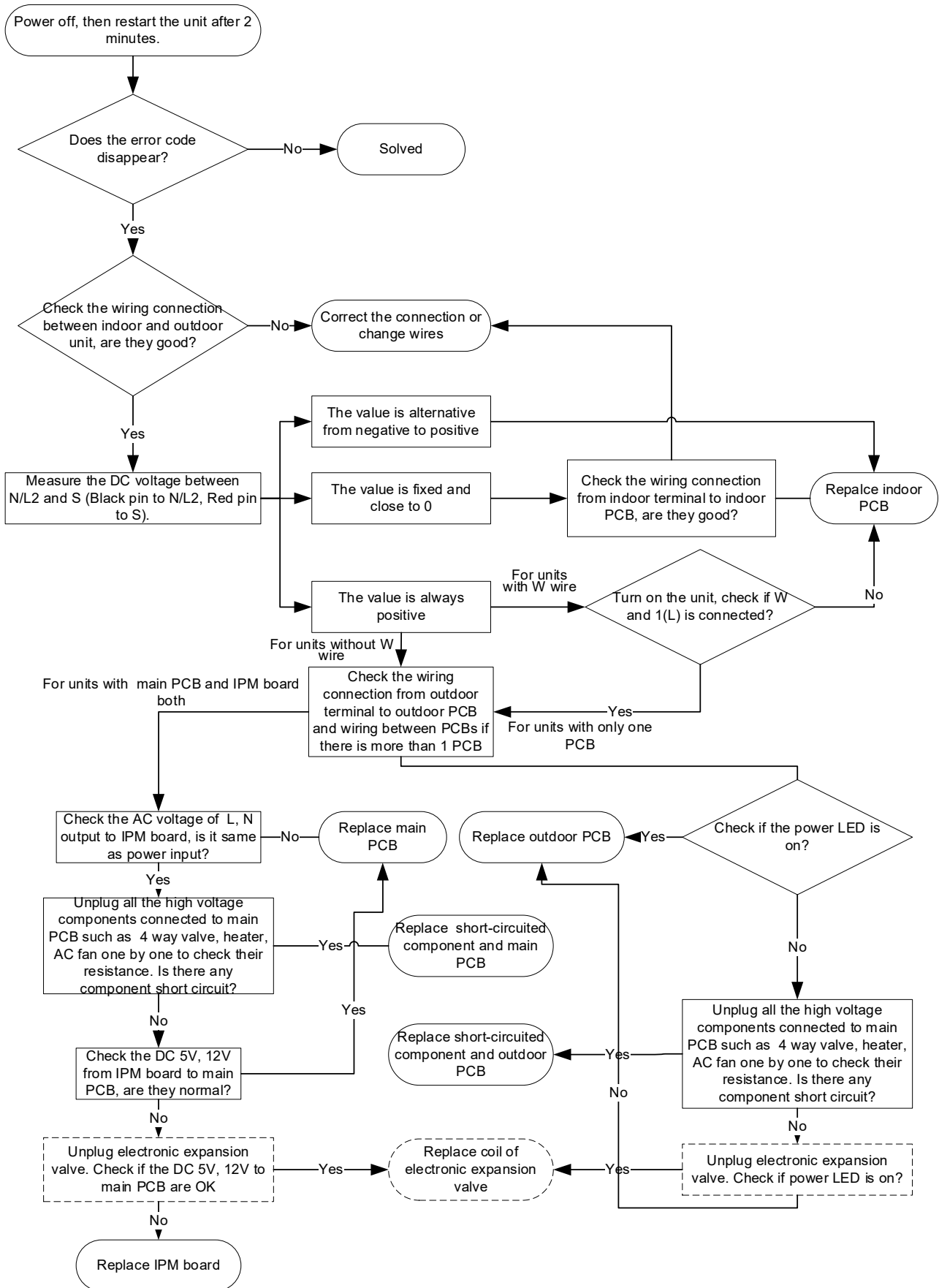

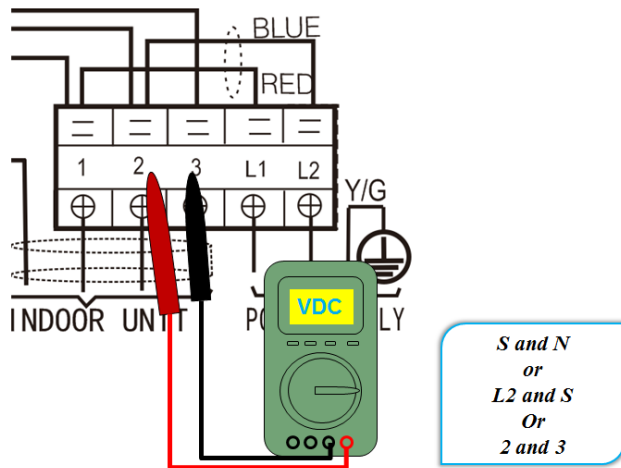

Remark:

Use a multimeter to test the DC voltage between 2 port and 3 port of outdoor unit. The red pin of multimeter connects with 2 port while the black pin is for 3 port.

When AC is normal running, the voltage will move alternately between -50V to 50V.

If the outdoor unit has malfunction, the voltage will move alternately with positive value.

While if the indoor unit has malfunction, the voltage will be a certain value.

Remark,

The old label is L1,L2,S, L1,L2

The new label is 1, 2, 3, L1,L2

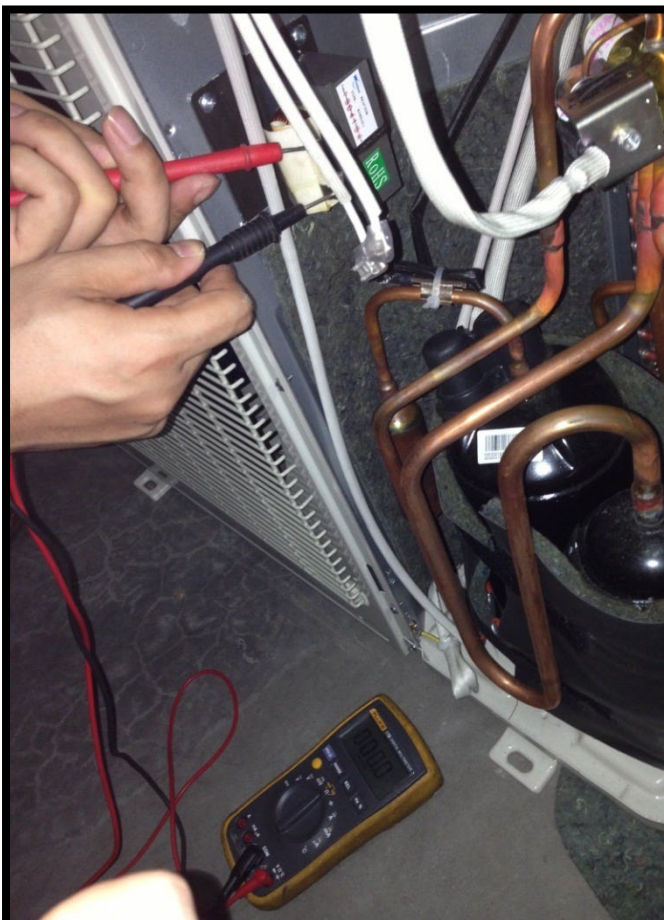

Remark:

Use a multimeter to test the resistance of the reactor which does not connect with capacitor.

The normal value should be around zero ohm. Otherwise, the reactor must have malfunction and need to be replaced.

For 36K-48K:

Malfunction conditions	Indoor unit does not receive feedback from outdoor unit for 60 seconds OR outdoor unit does not receive feedback from indoor unit for 120 seconds.
Possible causes	<ul style="list-style-type: none"> ● Wiring mistakes ● Faulty indoor or outdoor PCB

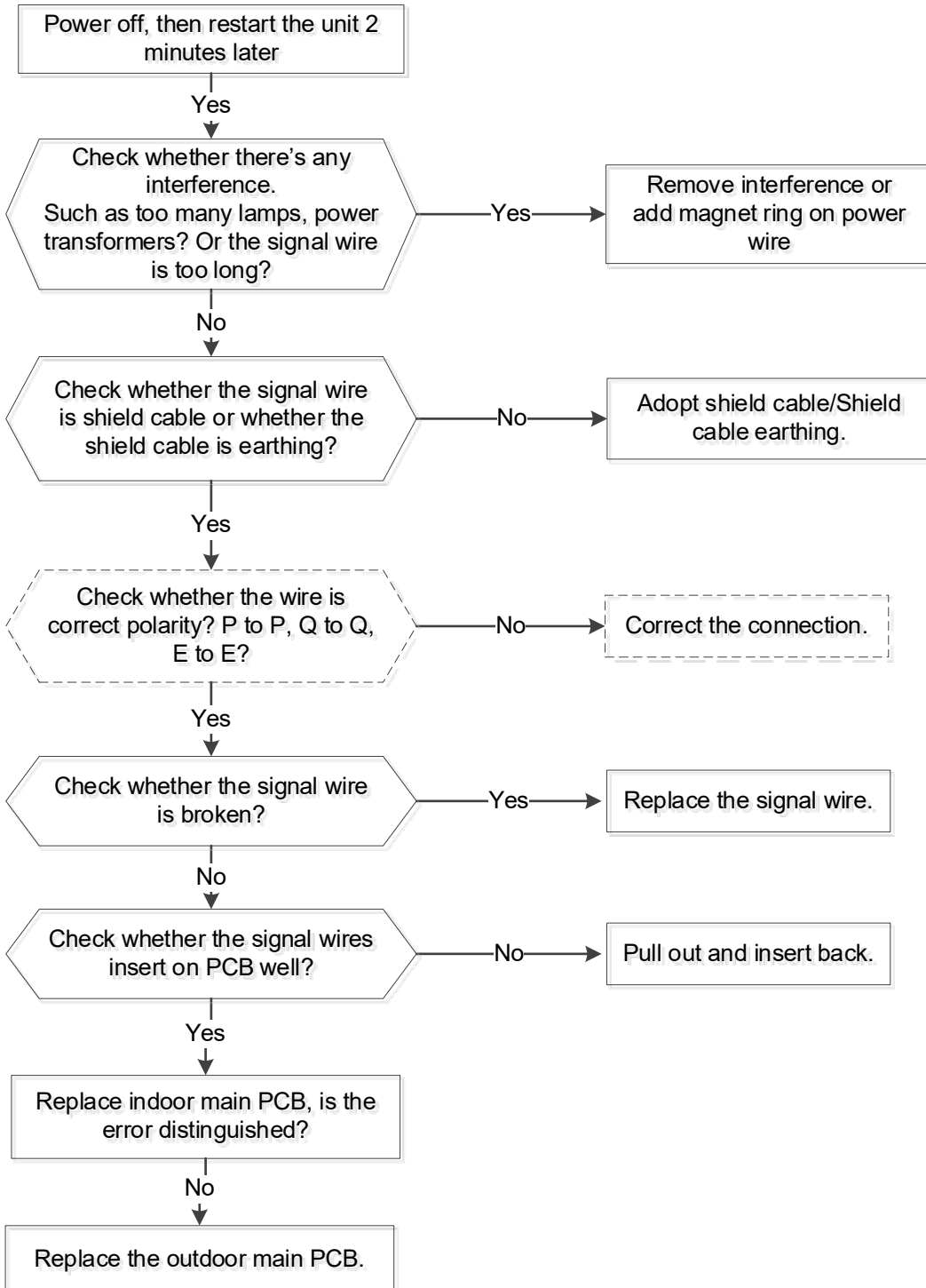

17.4.3 Fan speed malfunction diagnosis and solution

Error Code	E3/EH 03
Malfunction conditions	When indoor fan speed is too low (300RPM) for a certain period of time, the unit ceases operation and the LED displays a failure code.
Potential Causes	<ul style="list-style-type: none"> ● Wiring mistake ● Faulty fan assembly ● Faulty fan motor ● Faulty PCB

Trouble shooting:

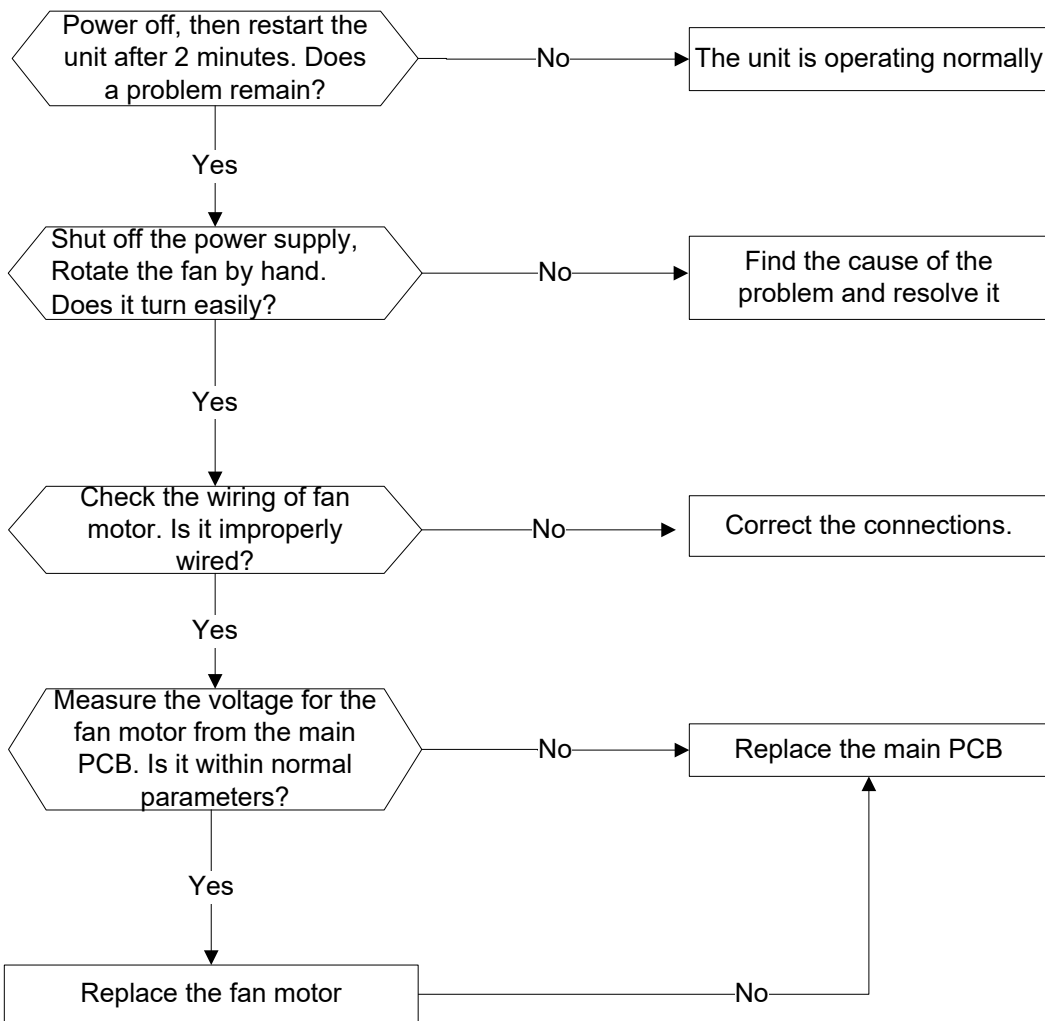

Index 1:

1. Indoor or outdoor DC fan motor (Control Chip is in Fan Motor)

Turn power on and while the unit is on standby, measure the voltage between pin1 and pin3 as well as between pin4 and pin3 in fan motor connector. If the value of the voltage is not within the range shown in the following table, the PCB may be experiencing problems and need to be replaced.

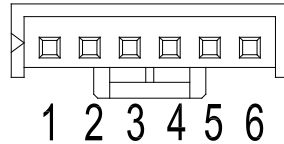

DC motor voltage input and output

NO.	Color	Signal	Voltage
1	Red	Vs/Vm	200~380V
2	---	---	---
3	Black	GND	0V
4	White	Vcc	13.5~16.5V
5	Yellow	Vsp	0~6.5V
6	Blue	FG	13.5~16.5V

2. Indoor DC Fan IPM Board (Duct and Ceiling-floor Unit)

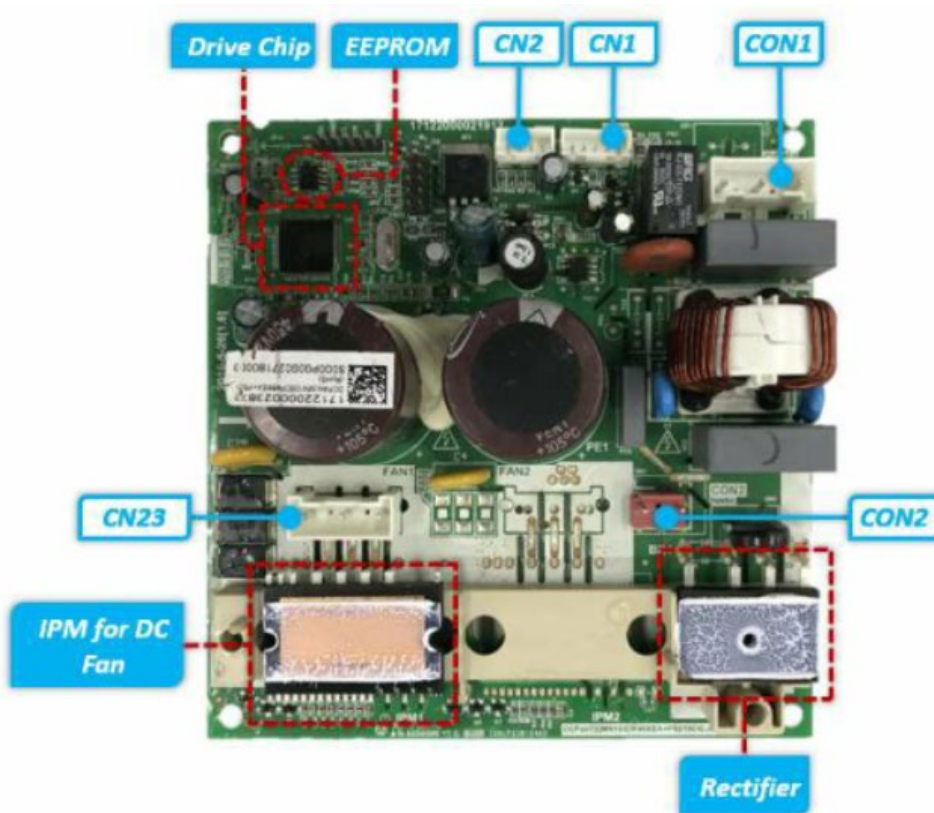

Port	Description	Parameter	Remark
CON1	Power input for the PCB	230V/AC	
CN1	Communication with main PCB	DC	
CN2	Test port	5V/DC	For debugging board
CN23	UVW output for DC fan motor		
CON2	Ports for reactor		

CN1 Communication with main PCB

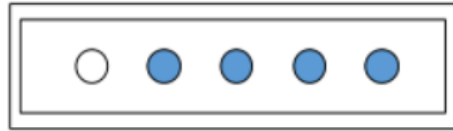

NO.	Signal	Voltage
1	Vcc	+15V
2	GND	
3	TXD	0~6V
4	RXD	0~15V
5	--	--

17.4.4 Fan speed malfunction diagnosis and solution

Error Code	F5/EC 07/EC 71
Malfunction conditions	When outdoor fan speed is too low or too high for a certain period of time, the unit ceases operation and the LED displays a failure code.
Potential Causes	<ul style="list-style-type: none"> ● Wiring mistake ● Faulty fan assembly ● Faulty fan motor ● Faulty PCB

Trouble shooting:

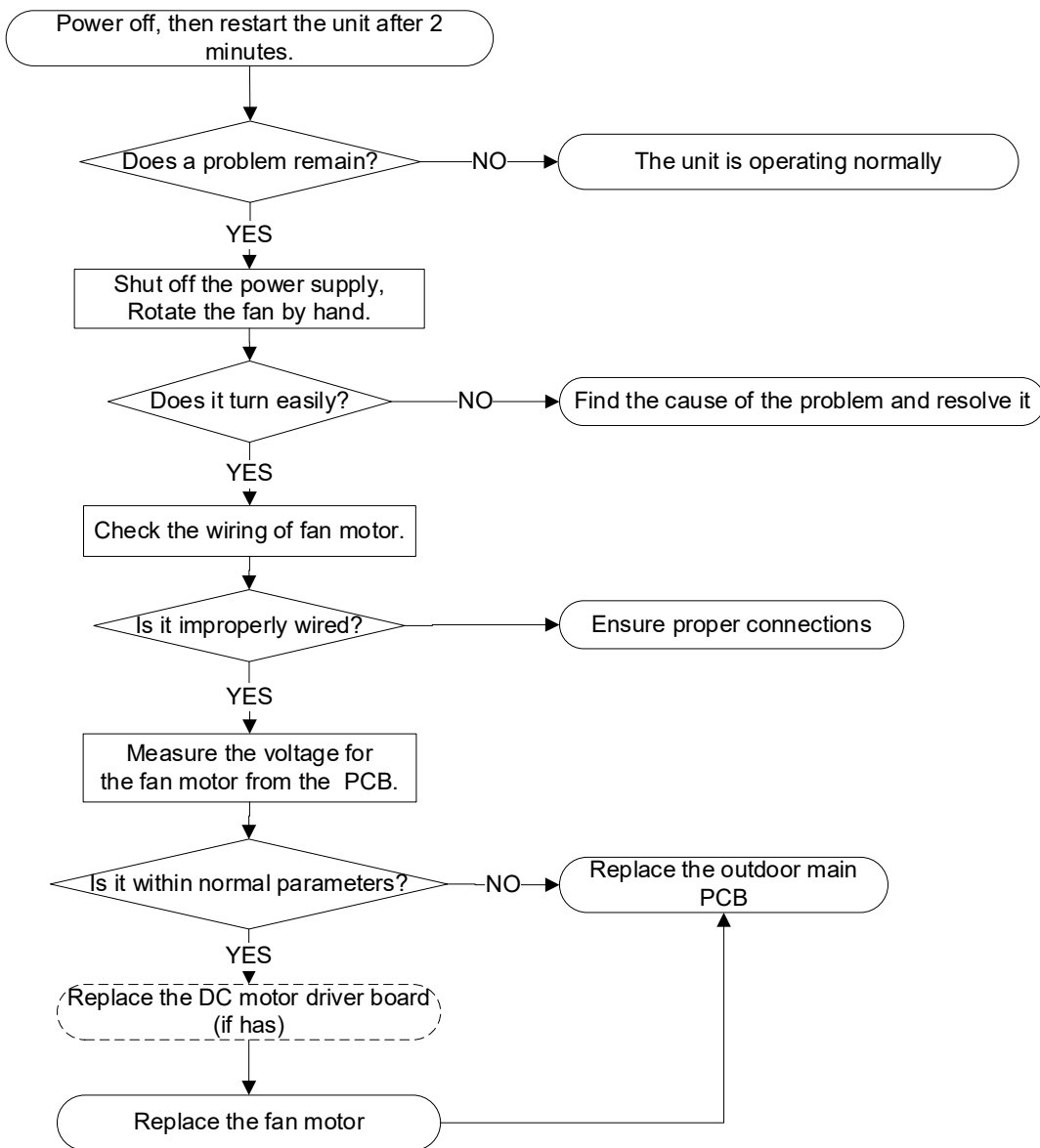

Index 1:

1. DC Fan Motor (control chip is in PCB)

Release the UVW connector. Measure the resistance of U-V, U-W, and V-W. If the resistances are not equal to each other, the fan motor may be experiencing problems and need to be replaced. Otherwise, the PCB must have problems and need to be replaced.

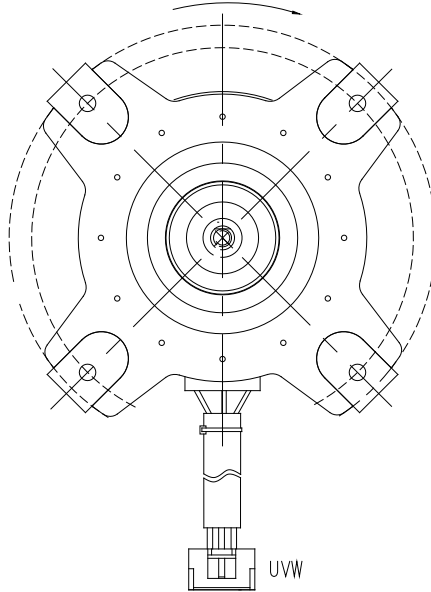

2. DC fan motor (Control Chip is in Fan Motor)

Turn power on and while the unit is on standby, measure the voltage between pin1 and pin3 as well as between pin4 and pin3 in fan motor connector. If the value of the voltage is not within the range shown in the following table, the PCB may be experiencing problems and need to be replaced.

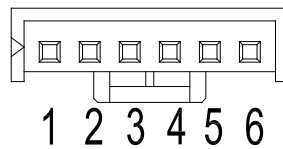

DC motor voltage input and output

NO.	Color	Signal	Voltage
1	Red	Vs/Vm	192~380V
2	---	---	---
3	Black	GND	0V
4	White	Vcc	13.5~16.5V
5	Yellow	Vsp	0~6.5V
6	Blue	FG	13.5~16.5V

3. DC Fan Motor(for some double fan models)

Power on and when the unit is in standby, measure the voltage of CON1, pin1-pin2 and pin3-pin2 of CN1 in DC motor driver board. If the value of the voltage is not in the range

showing in below tables, the outdoor main PCB must has problems and need to be replaced.

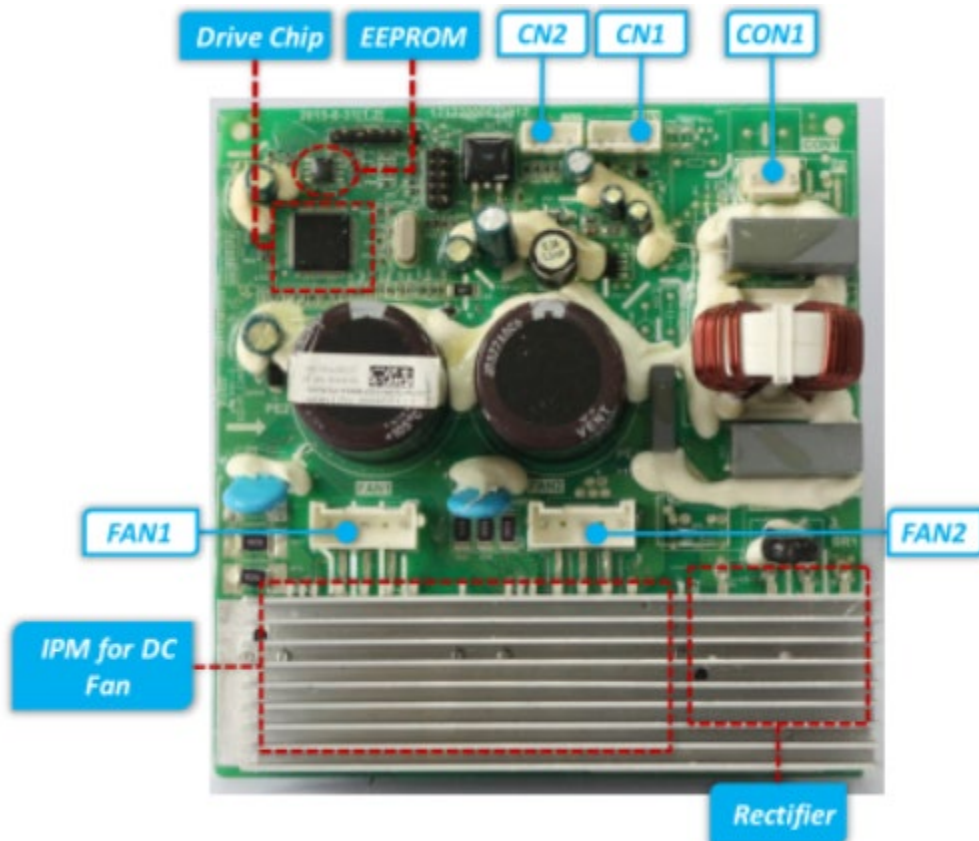

Port	Description	Parameter	Remark
CON1	Power input for the PCB	192-380V/DC	
CN1	Communication with main PCB	DC	
CN2	Test port	5V/DC	For debugging board
FAN1	UVW output for DC fan motor		
FAN2	UVW output for DC fan motor		

CN1 Communication with main PCB

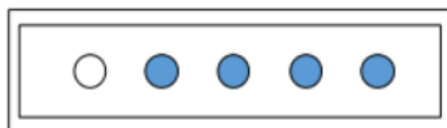

NO.	Signal	Voltage
1	Vcc	+15V
2	GND	
3	TXD	0~6V
4	RXD	0~15V
5	--	--

17.4.5 Open or short circuit of temperature sensor diagnosis and solution

Error Code	E4/E5/F1/F2/F3/EH 60/EH 61/EC 53/EC 52/EC 54
Malfunction conditions	If the sampling voltage is lower than 0.06V or higher than 4.94V, the LED displays a failure.
Potential causes	<ul style="list-style-type: none">• Wiring mistake• Faulty sensor

Trouble shooting:

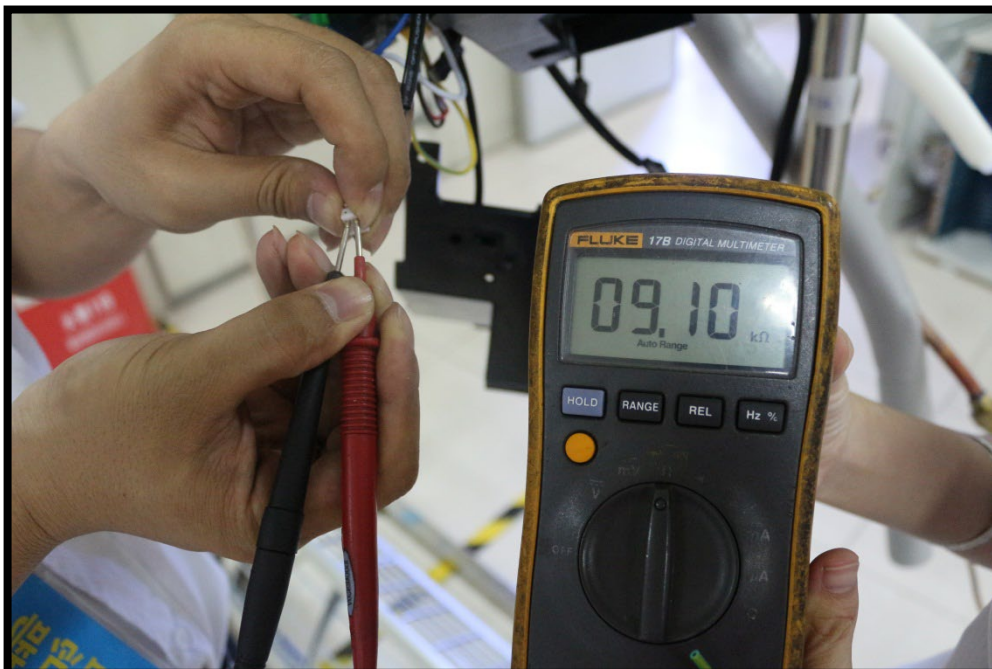
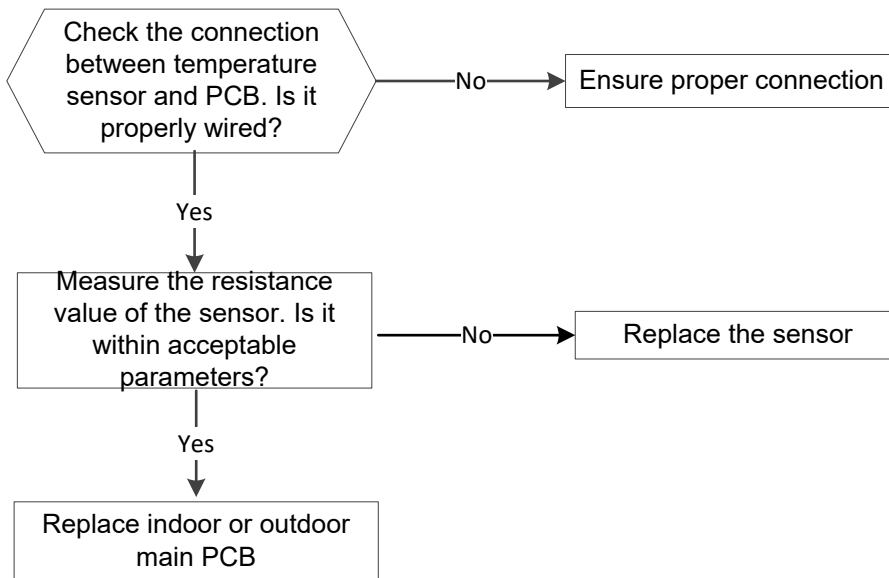

17.4.6 Refrigerant Leakage Detection diagnosis and solution

Error Code	EC/EL 0C
Malfunction conditions	<p>Define the evaporator coil temperature T2 of the compressor starts running as Tcool.</p> <p>If the following occurs 3 times, the display shows "EC" and the unit switches off:</p> <p>In the first 8 minutes after the compressor starts up, if $T2 < T_{cool} - 2^{\circ}\text{C}$ is not maintained for 4 seconds and compressor running frequency is not higher than 50Hz for 3 minutes.</p> <p>For new cassette: Judging the abnormality of the refrigeration system according to the number of compressor stops and the changes in operating parameters caused by excessive exhaust temperature.</p>
Potential Causes	<ul style="list-style-type: none"> ● Faulty T2 sensor ● Faulty indoor PCB ● System problems, such as leakage or blockages

Trouble shooting:

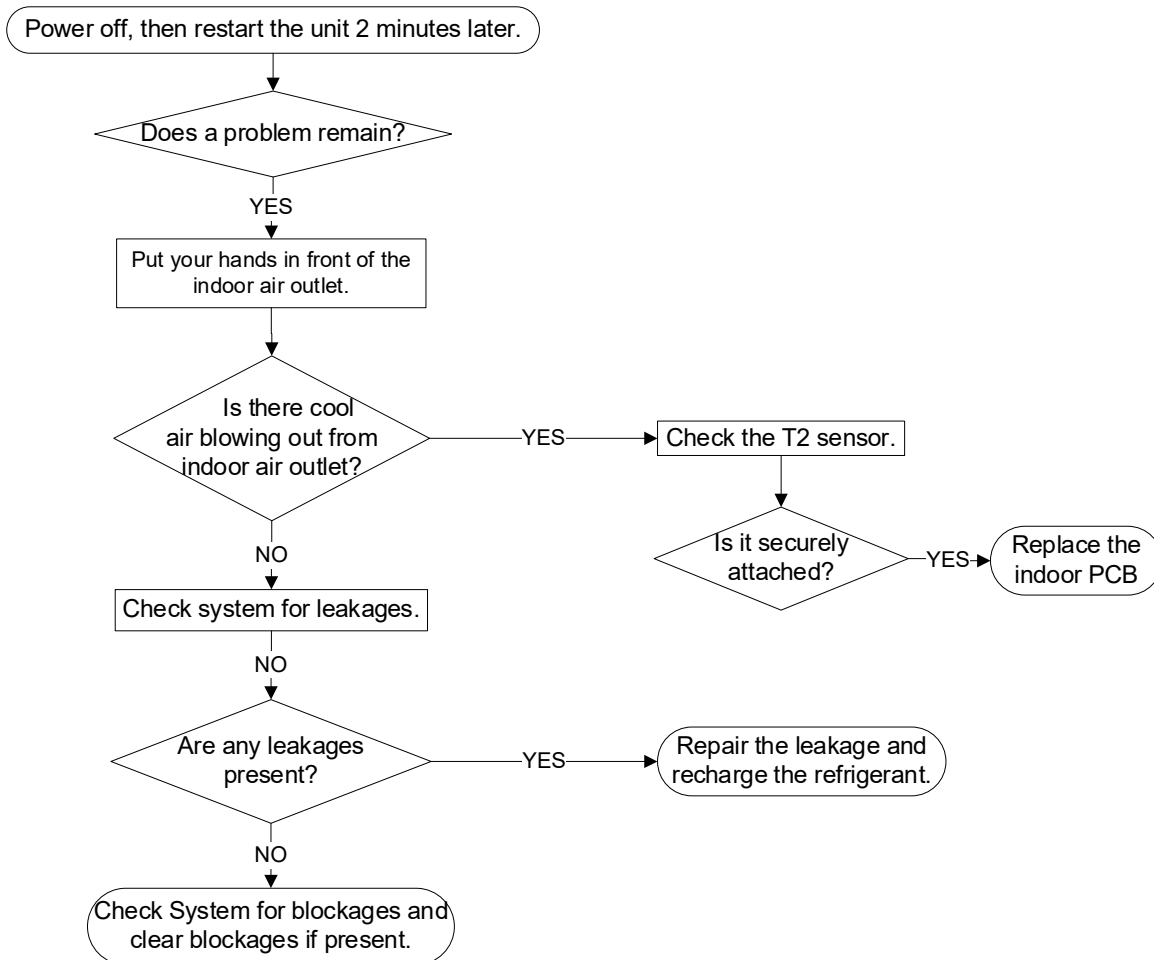

For new cassette:

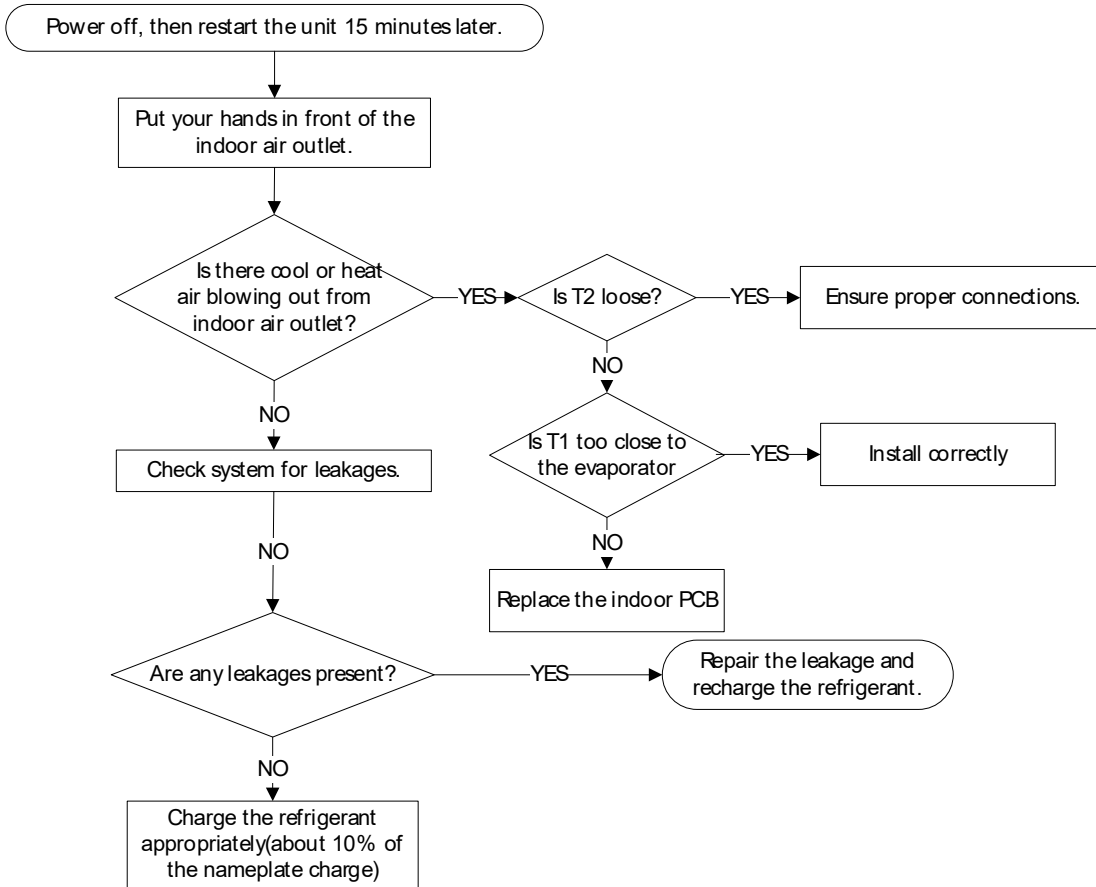

17.4.7 Water-level alarm malfunction diagnosis and solution

Error Code	EE/EH 0E
Malfunction conditions	If the sampling voltage is not 5V, the LED will display the failure code.
Possible causes	<ul style="list-style-type: none"> ● Wiring mistakes ● Faulty water-level switch ● Faulty water pump ● Faulty indoor PCB

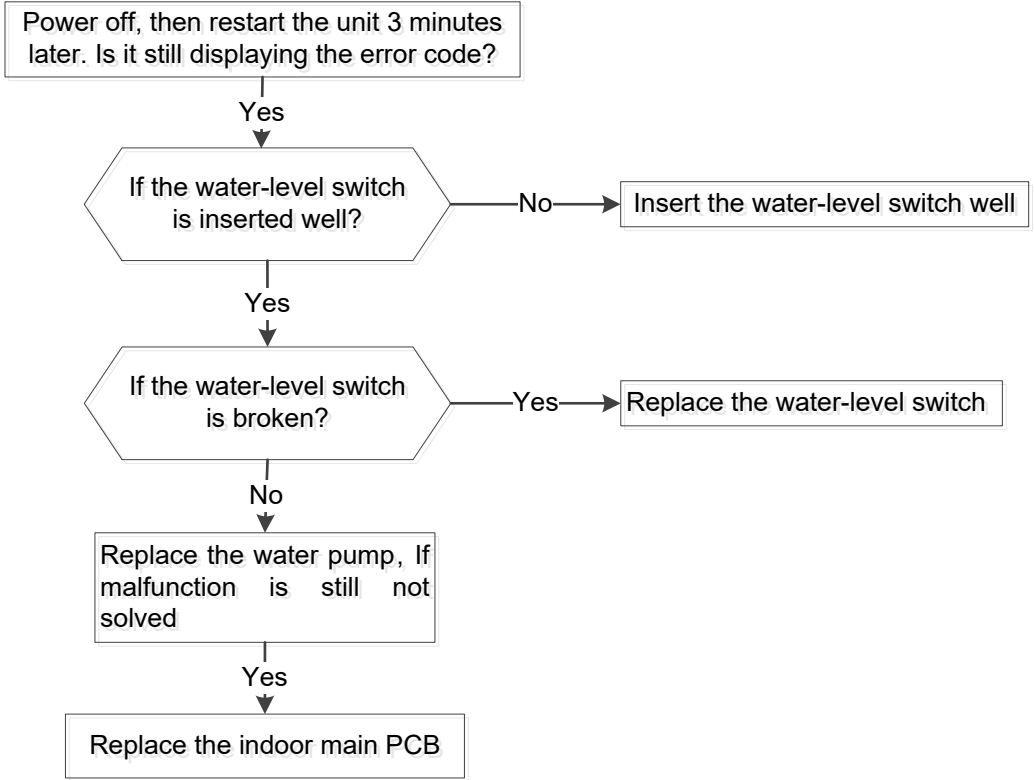

17.4.8 IPM malfunction or IGBT over-strong current protection diagnosis and solution

Error Code	P0/PC 00
Malfunction conditions	When the voltage signal the IPM sends to the compressor drive chip is abnormal, the display LED shows failure code and the AC turn off.
Possible causes	<ul style="list-style-type: none"> ● Wiring mistake ● IPM malfunction

Trouble shooting:

First, test the resistance between every two ports of U, V, the W of the IPM and P, N. If any of the results is 0 or close to 0, the IPM is defective. If not, follow the following procedure:



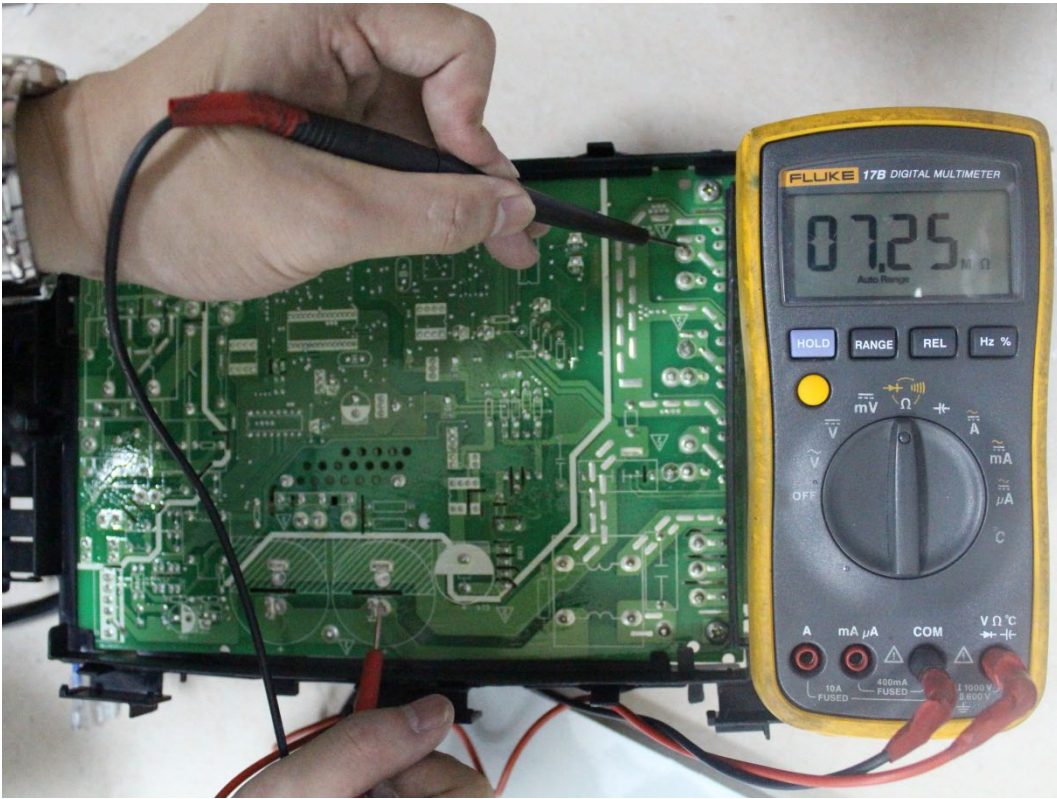

P-U

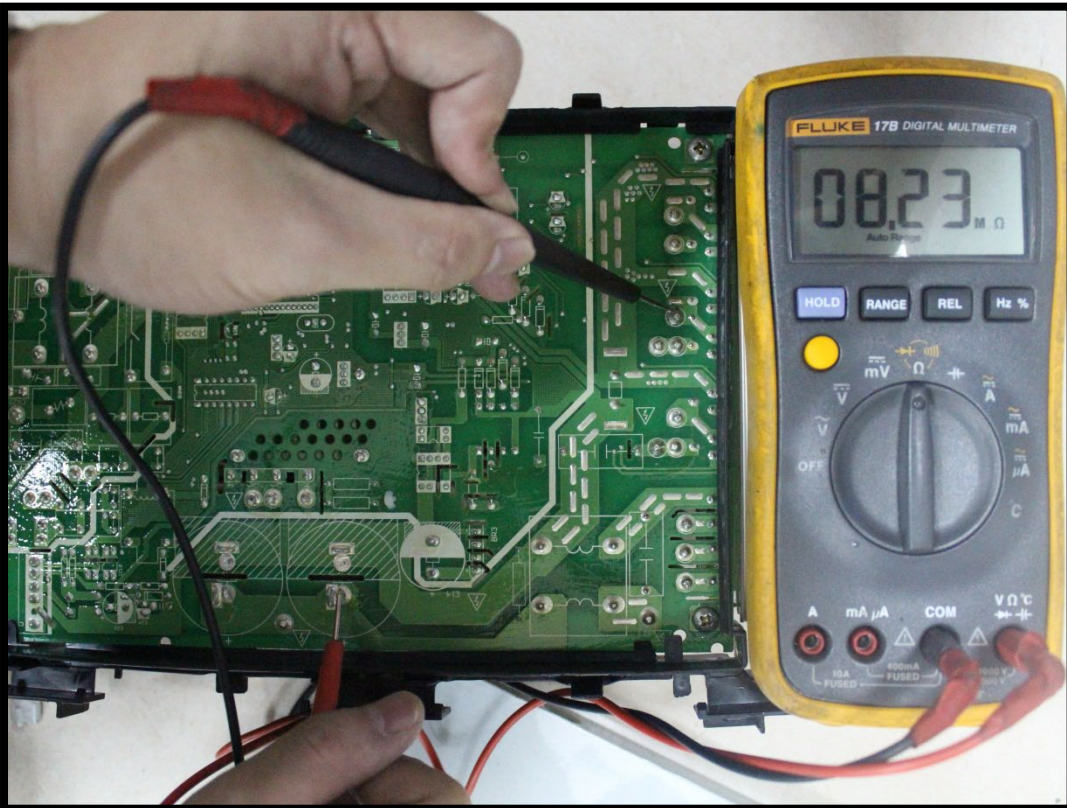

P-V

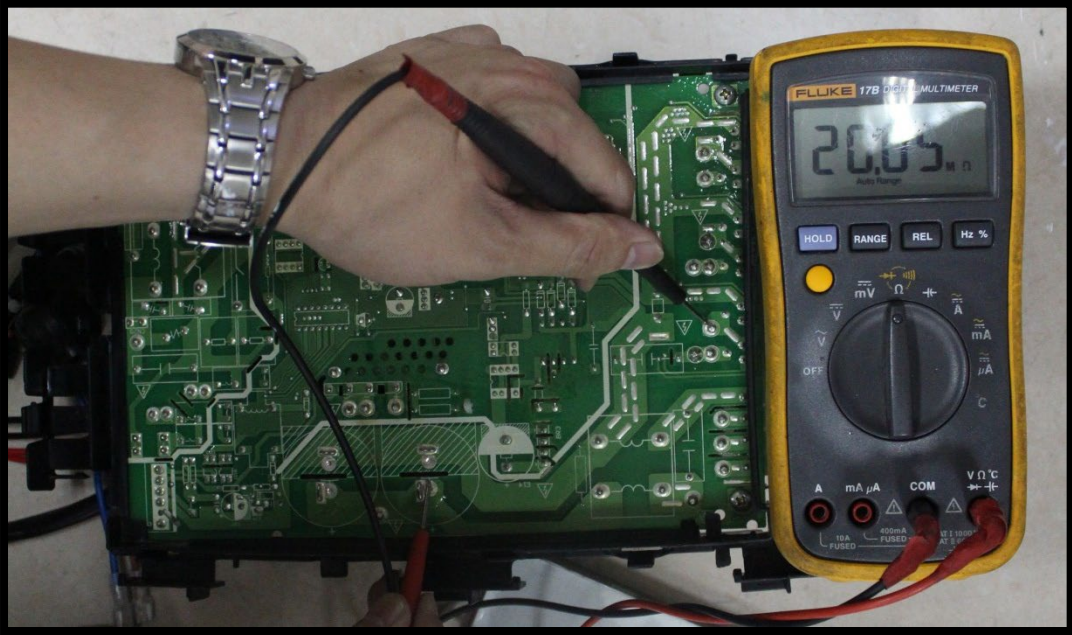

P-W

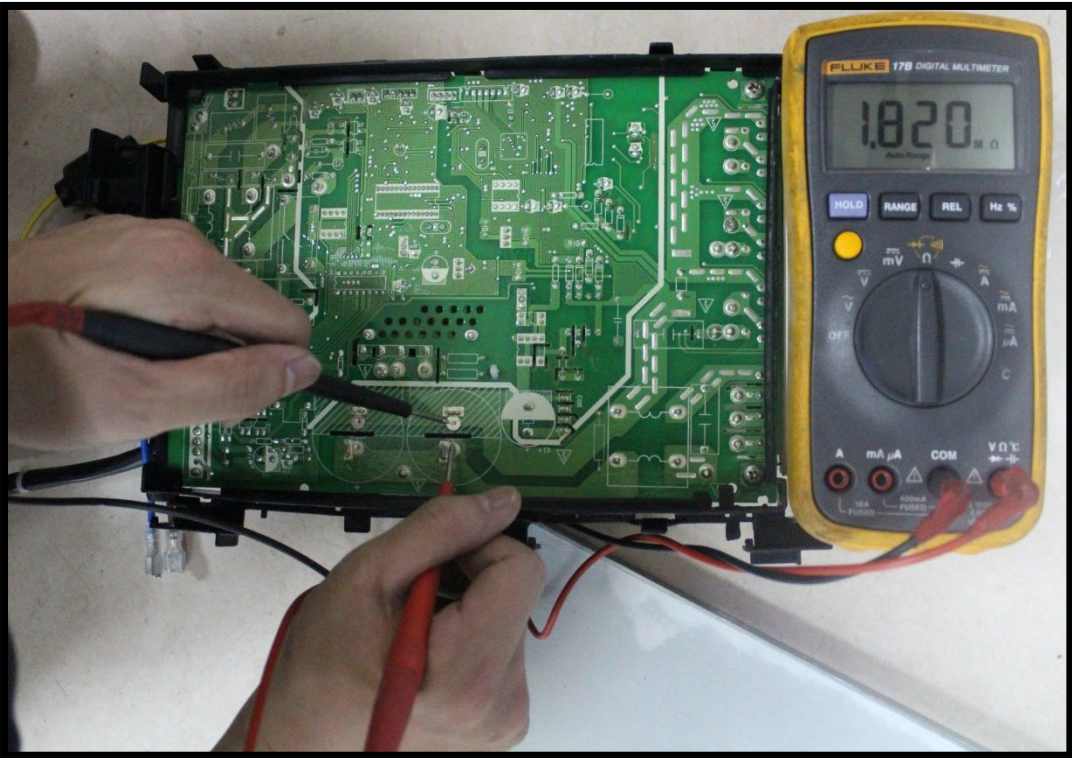

P-N

17.4.9 Over-voltage or under-voltage protection diagnosis and solution

Error Code	P1/ PC 01/ PC 10/ PC 11/ PC 12
Malfunction conditions	Abnormal increases or decreases in voltage are detected by checking the specified voltage detection circuit.
Potential causes	<ul style="list-style-type: none"> • Power supply issues • System leakage or blockage • Faulty PCB

Trouble shooting:

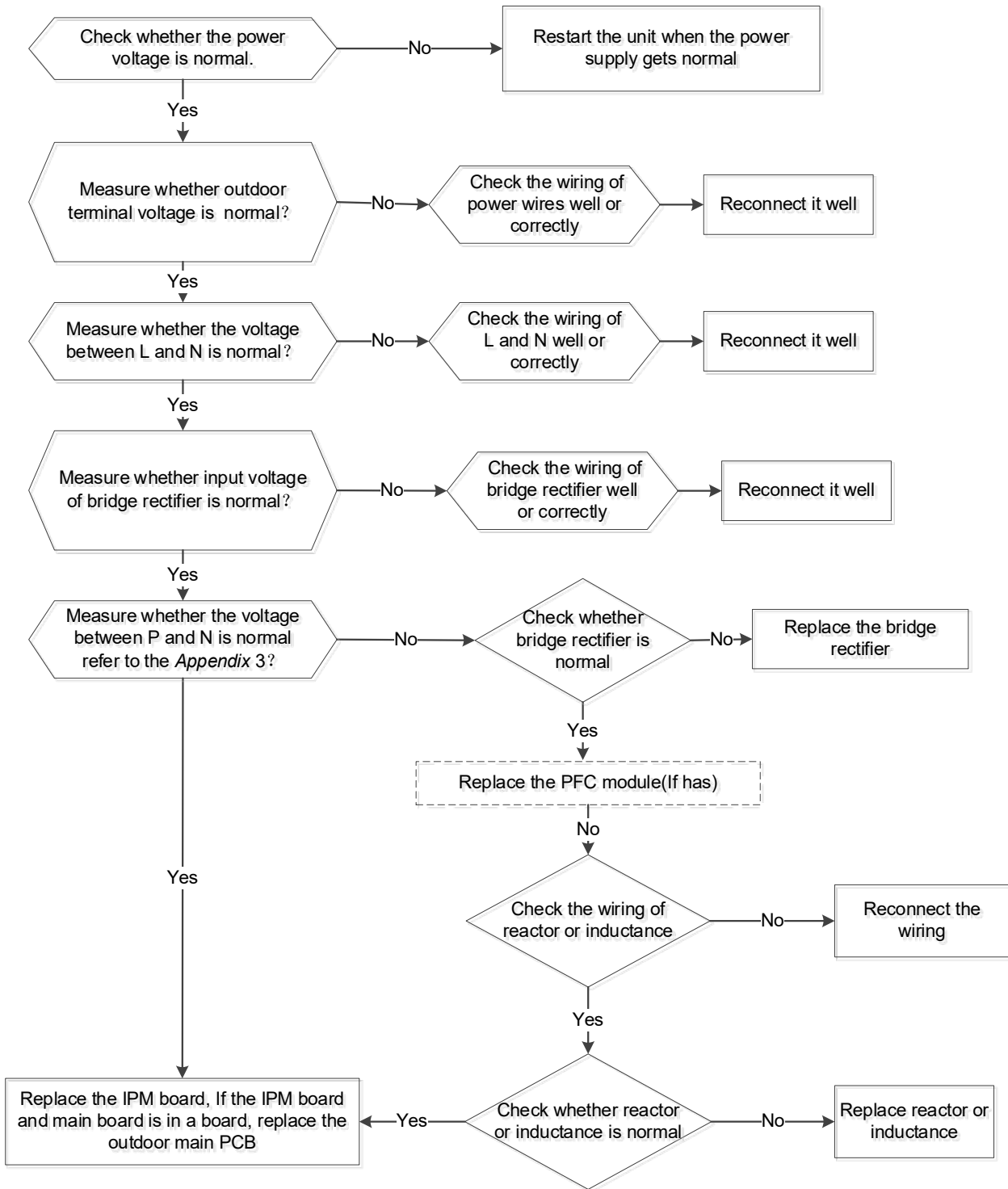

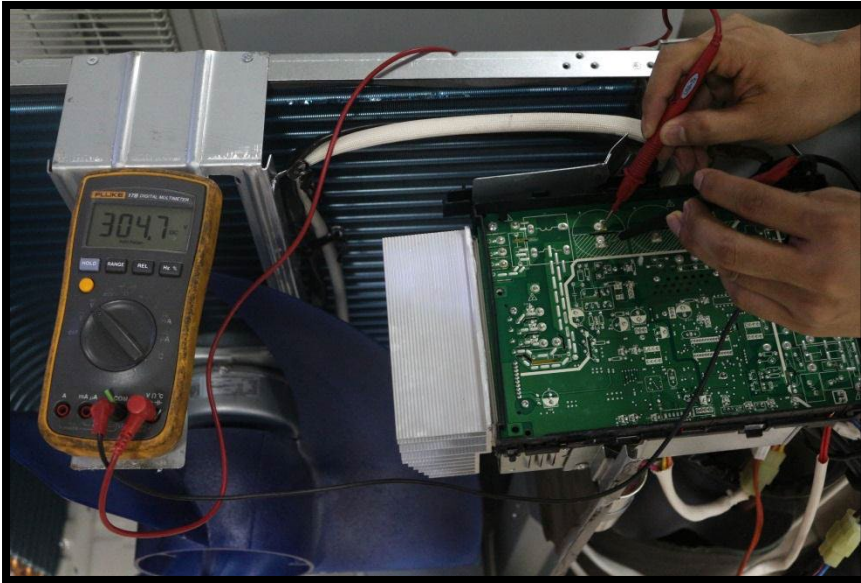

Remark:

Measure the DC voltage between P and N port. The normal value should be around 310V.340V or 380V

17.4.10 High temperature protection of compressor top diagnosis and solution

Error Code	P2/PC 02
Malfunction decision conditions	If the sampling voltage is not 5V, the LED will display the failure.
Supposed causes	<ul style="list-style-type: none"> ● Power supply problems. ● System leakage or block ● PCB faulty

Trouble shooting:

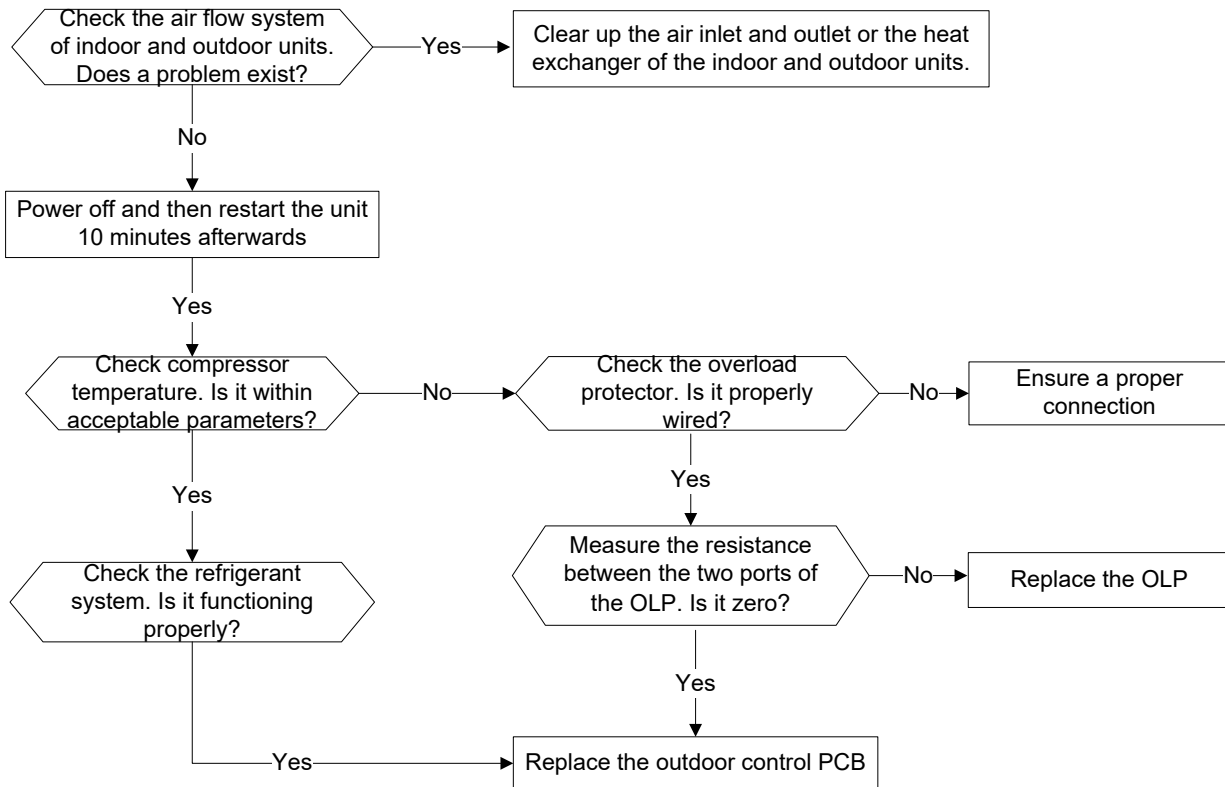

High temperature protection of IPM board diagnosis and solution (P2)

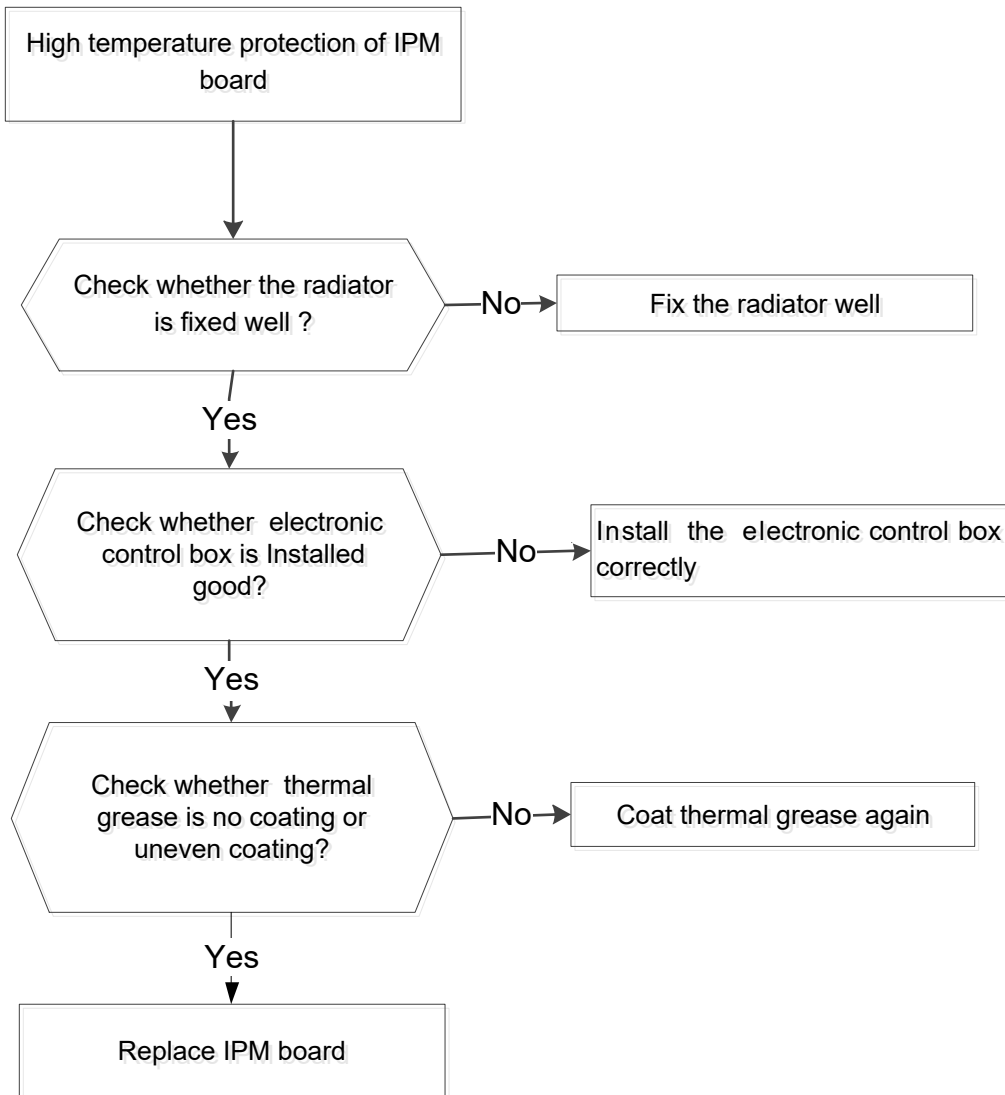

17.4.11 Inverter compressor drive error diagnosis and solution

Error Code	P4/ PC 04
Malfunction conditions	Abnormalities in the inverter compressor drive is detected by a special detection circuit, which can perform communication signal detection, voltage detection, and compressor rotation speed signal detection.
Potential causes	<ul style="list-style-type: none"> ● Wiring mistake ● IPM malfunction ● Faulty outdoor fan assembly ● Compressor malfunction ● Faulty outdoor PCB

Trouble shooting:

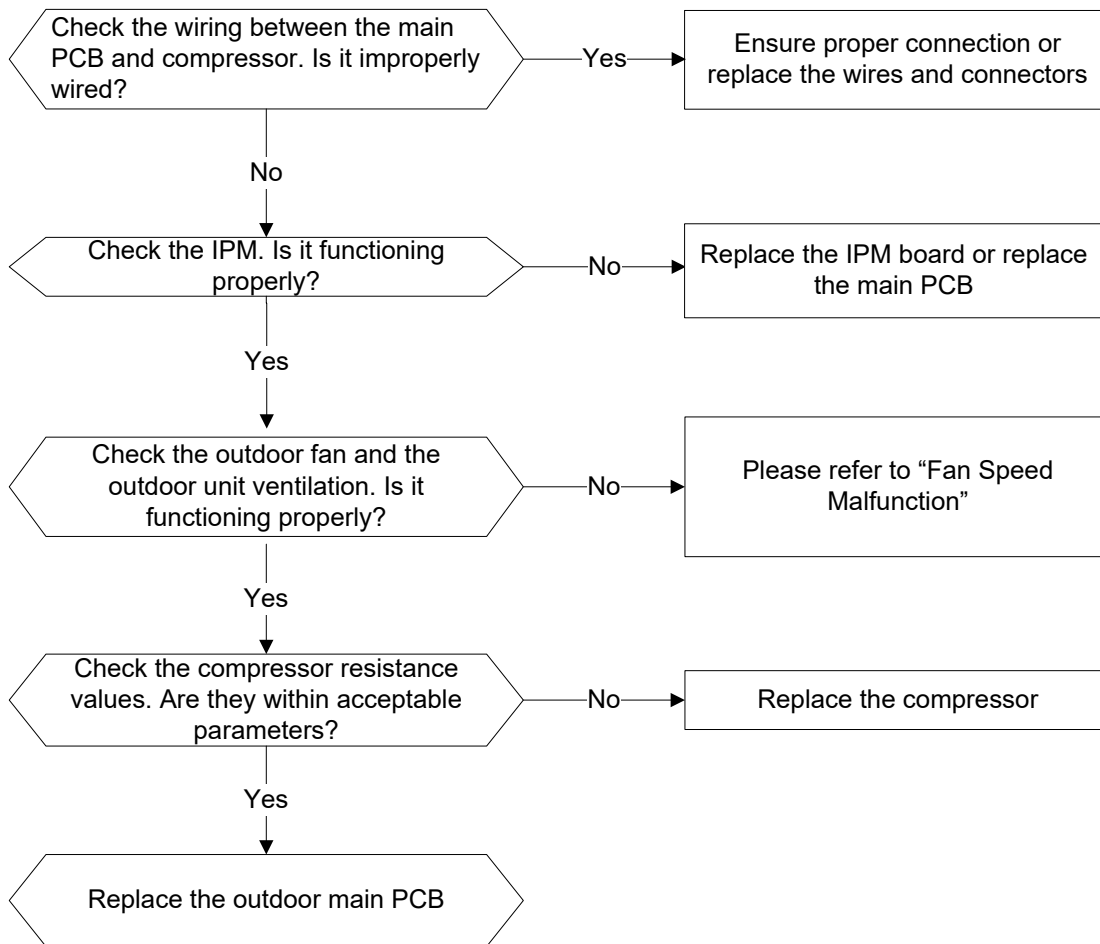

17.4.12 Outdoor IPM module temperature sensor malfunction diagnosis and solution

Error Code	P7/ EC 55
Malfunction conditions	If the sampling voltage is lower than 0.06V or higher than 4.94V, the LED displays a failure.
Potential causes	<ul style="list-style-type: none">● Wiring mistake● Faulty sensor

Trouble shooting:

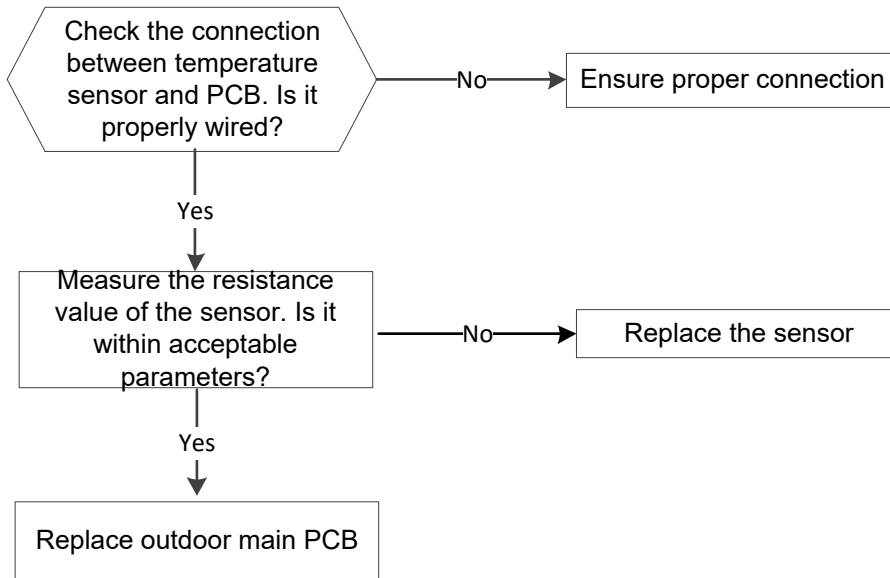

17.4.13. J0 Malfunction

Error Code	J0
Malfunction conditions	When evaporator coil temperature is more than 60°C, the unit stops. It starts again only when the evaporator coil temperature is less than 54°C
Possible causes	<ul style="list-style-type: none"> • Faulty evaporator coil temperature sensor • Dirty heat exchanger • Faulty fan • Faulty PCB

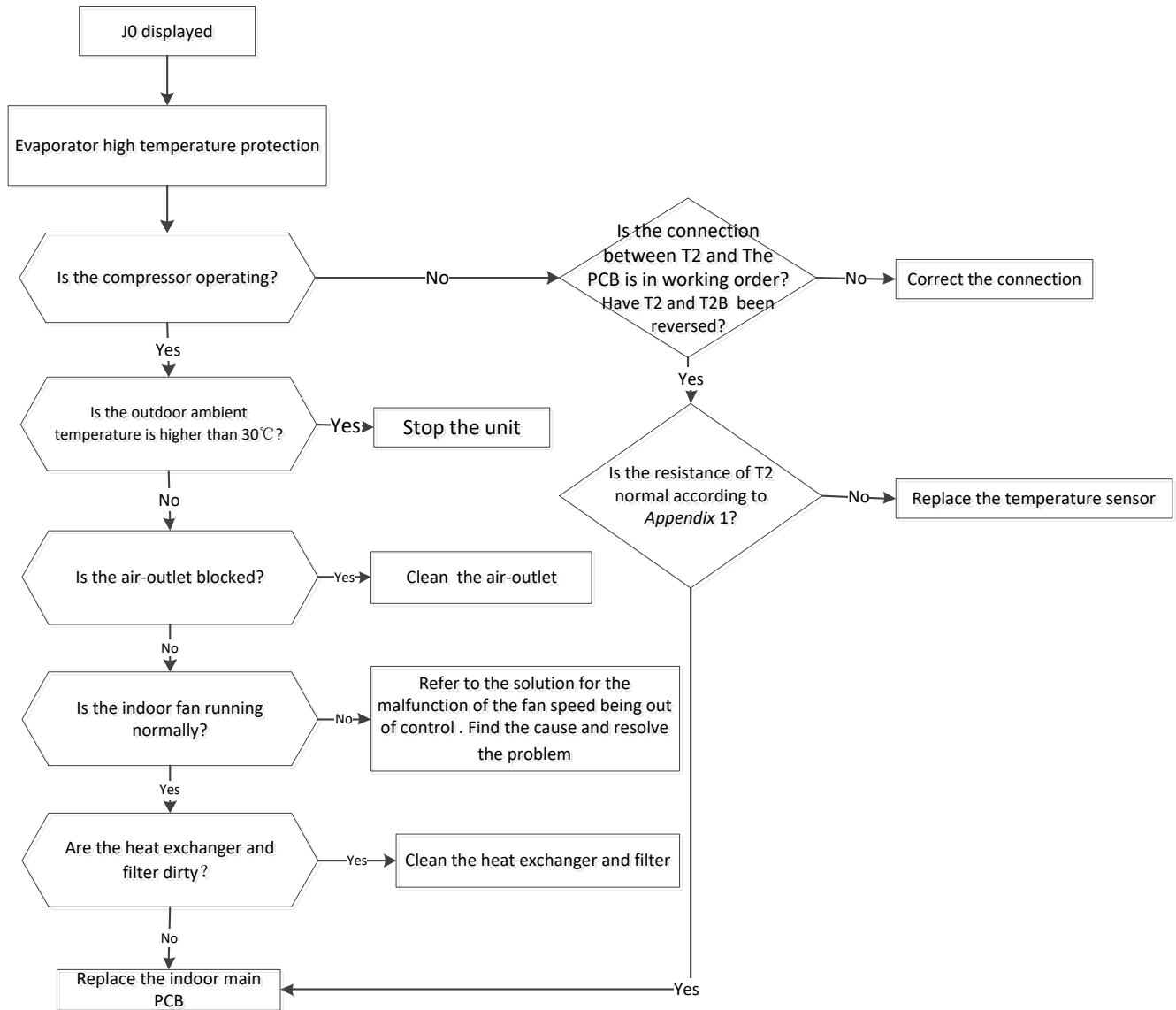

17.4.14. J1/ PC 0A Malfunction

Error Code	J1/ PC 0A
Malfunction conditions	When the outdoor pipe temperature is more than 65°C, the unit stops. It starts again only when the outdoor pipe temperature is less than 52°C.
Possible causes	<ul style="list-style-type: none"> ● Faulty condenser temperature sensor ● Dirty heat exchanger ● System leakage or blockages

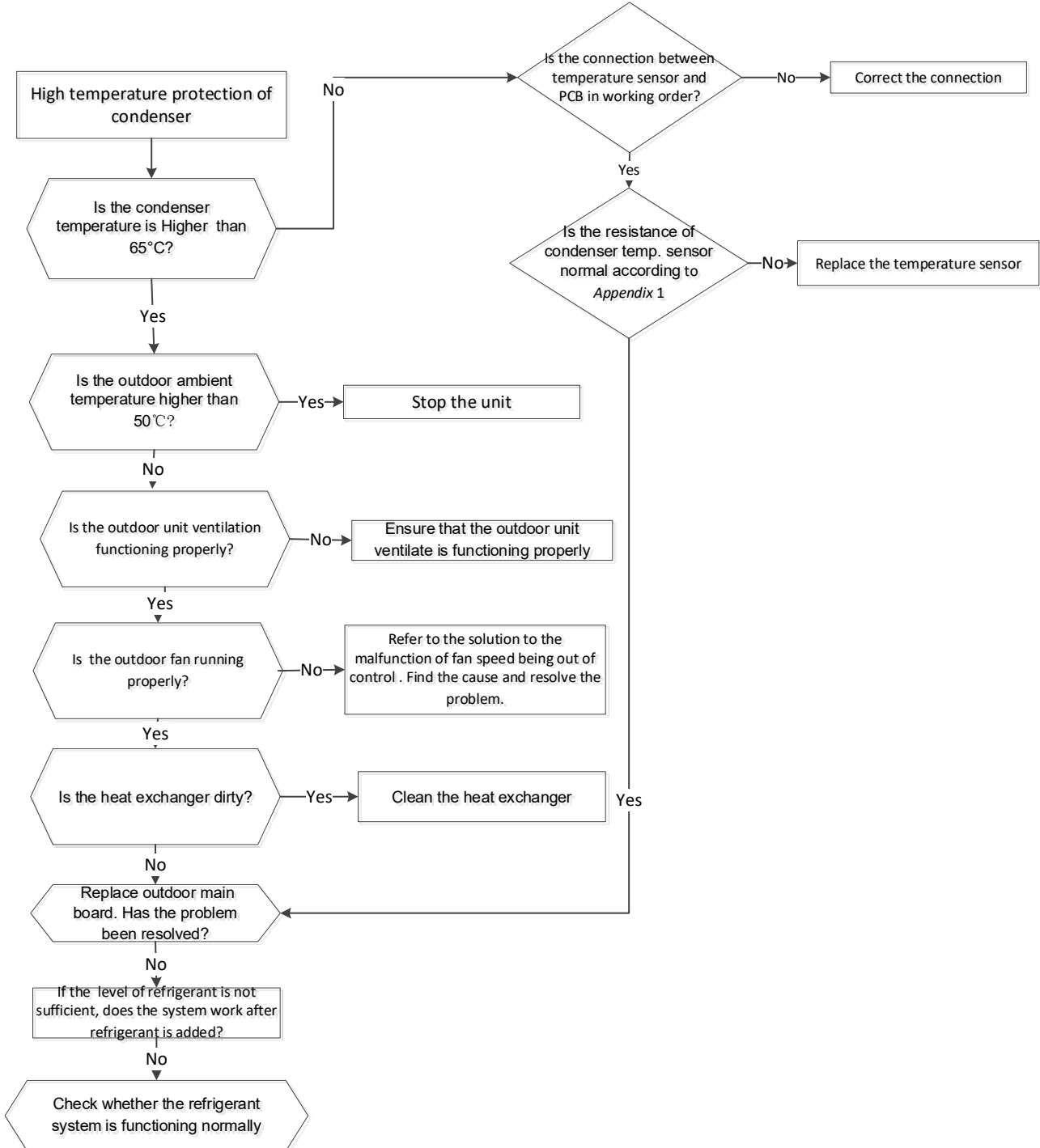

17.4.15. J2/ PC 06 Malfunction

Error Code	J2/ PC 06
Malfunction conditions	When the compressor discharge temperature (T5) is more than 115°C for 10 seconds, the compressor will stop and not restart until T5 is less than 90°C.
Possible causes	<ul style="list-style-type: none"> ● Refrigerant leakage ● Wiring mistake ● Faulty discharge temperature sensor ● Faulty outdoor PCB

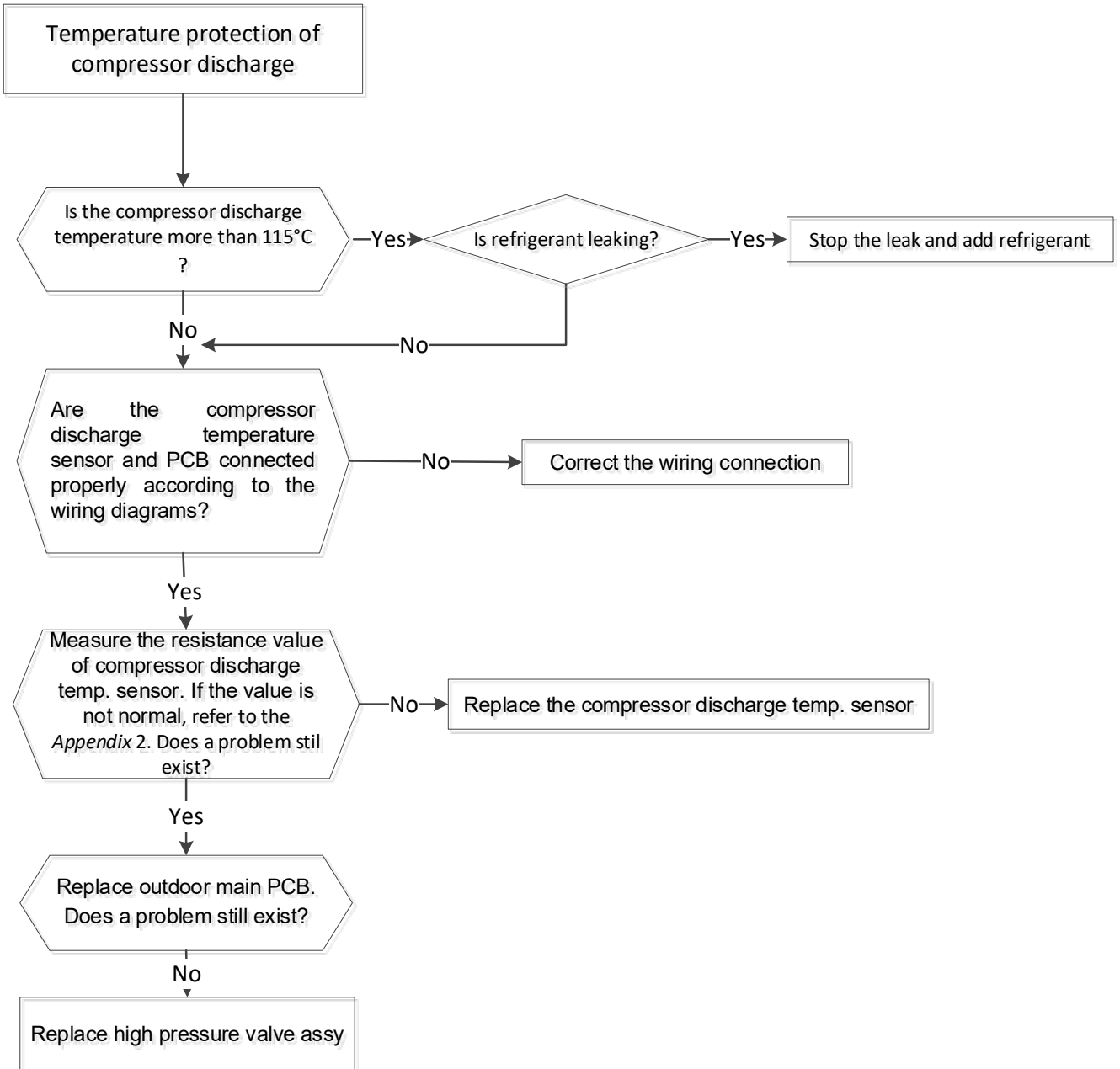

17.4.16. J3/PC 0F Malfunction

Error Code	J3/PC 0F
Malfunction conditions decision	When the voltage signal that IPM send to compressor drive chip is abnormal, the display LED will show failure code and AC will turn off.
Supposed causes	<ul style="list-style-type: none"> ● Wiring mistake ● Faulty IPM board ● Faulty outdoor fan ass'y ● Compressor malfunction ● Faulty outdoor PCB

At first test the resistance between every two ports of U, V, W of IPM and P, N. If any result of them is 0 or close to 0, the IPM is defective. Otherwise, please follow the procedure below:

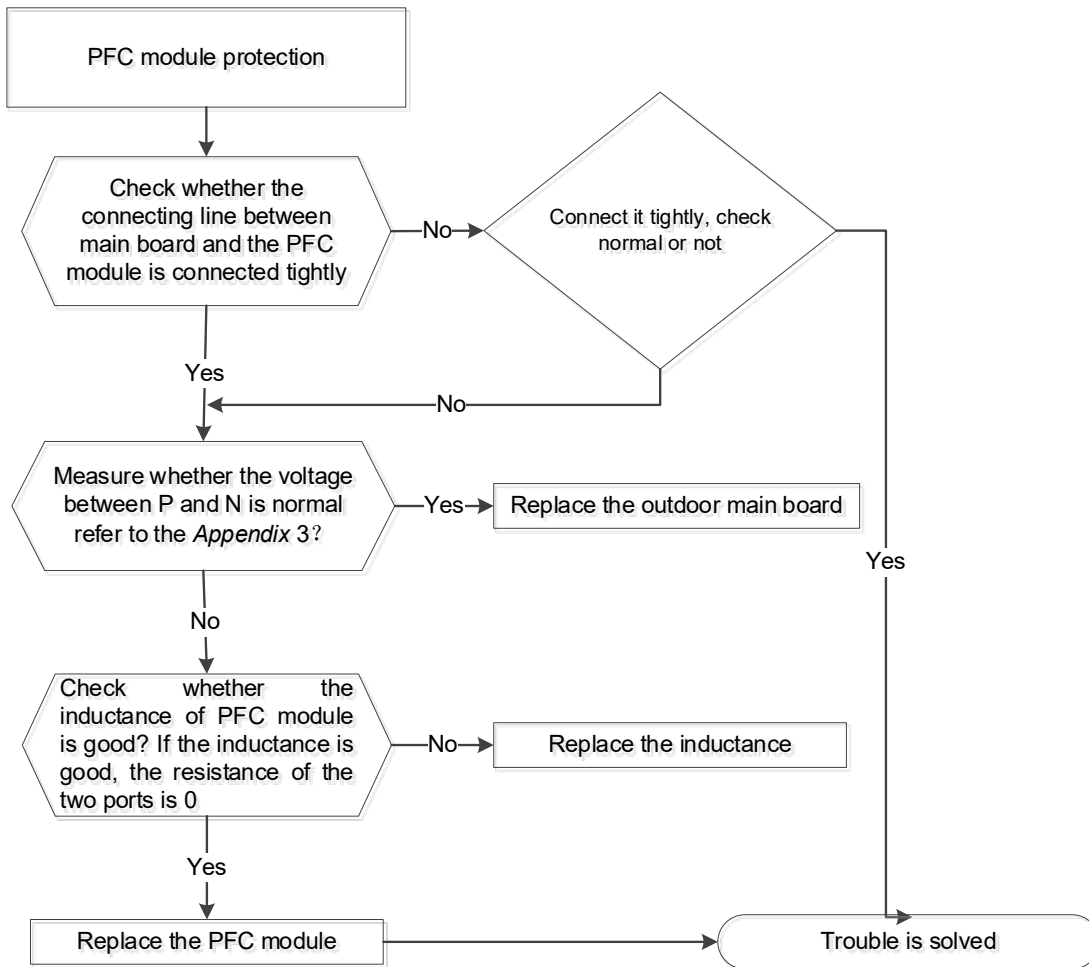

17.4.17. J4/ PC 40 Malfunction

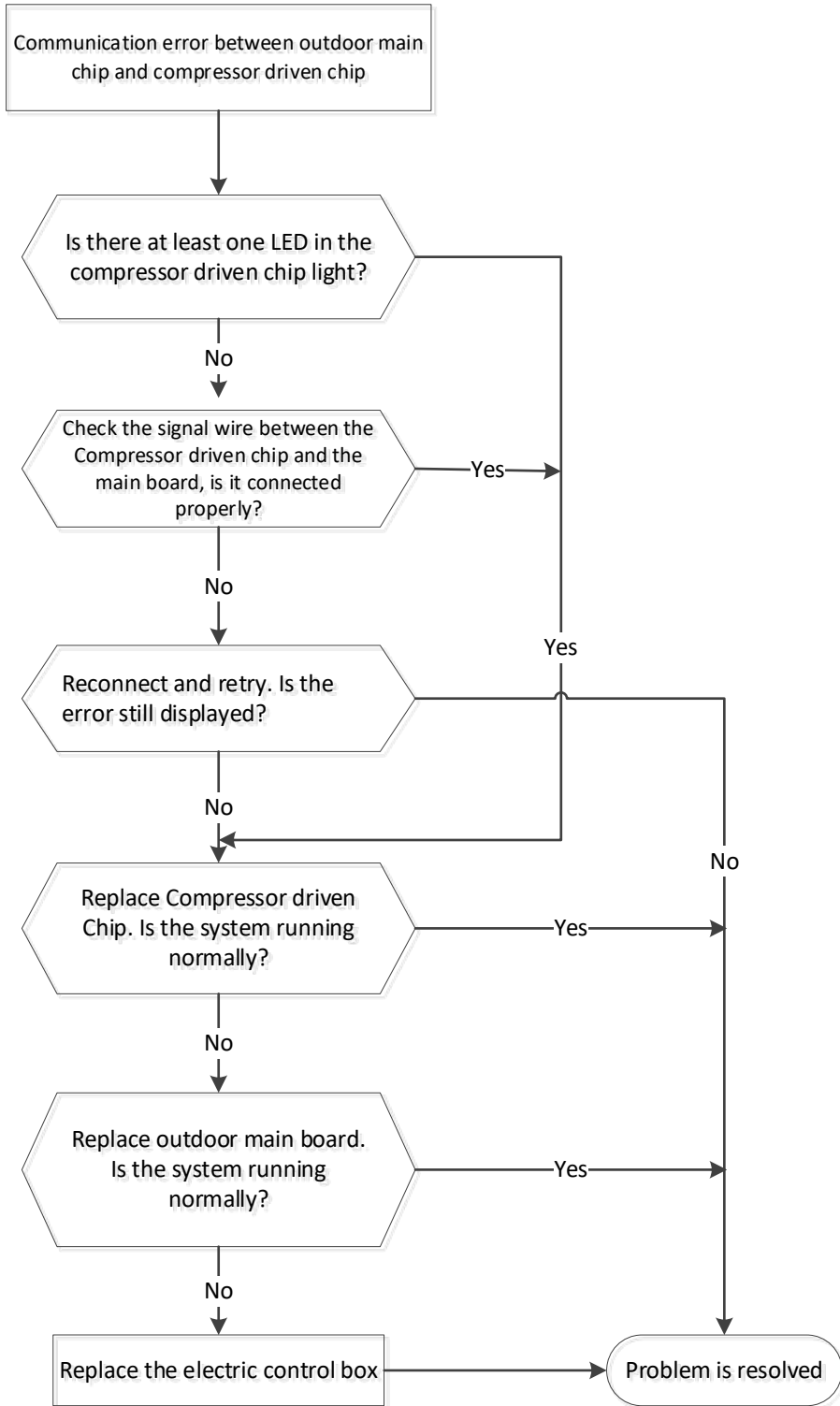

17.4.18. P6/J5/PC 30 Malfunction

Error Code	P6/J5/PC 30
Malfunction conditions	Outdoor pressure switch cut off the system because high pressure is higher than 4.4 MPa.
Possible causes	<ul style="list-style-type: none"> ● Wiring mistakes ● Faulty pressure protector ● Faulty outdoor fan ● System blockages ● Faulty outdoor PCB

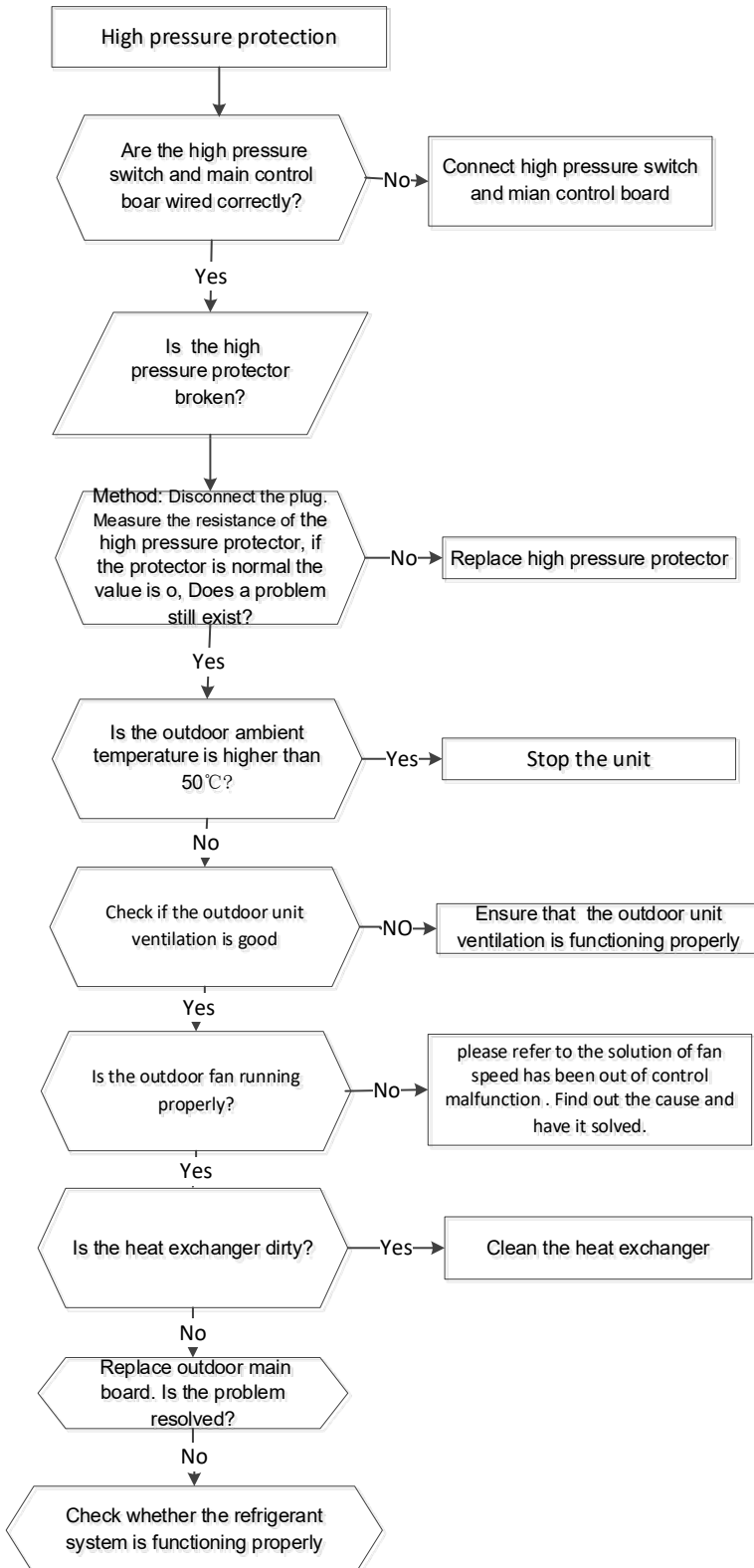

17.4.19. J6/P6/PC 31 Malfunction

Error Code	J6/P6/PC 31
Malfunction conditions	Outdoor pressure switch cut off the system because low pressure is lower than 0.13 MPa.
Possible causes	<ul style="list-style-type: none">● Wiring mistake● Faulty pressure protector● System blockages● Faulty outdoor PCB

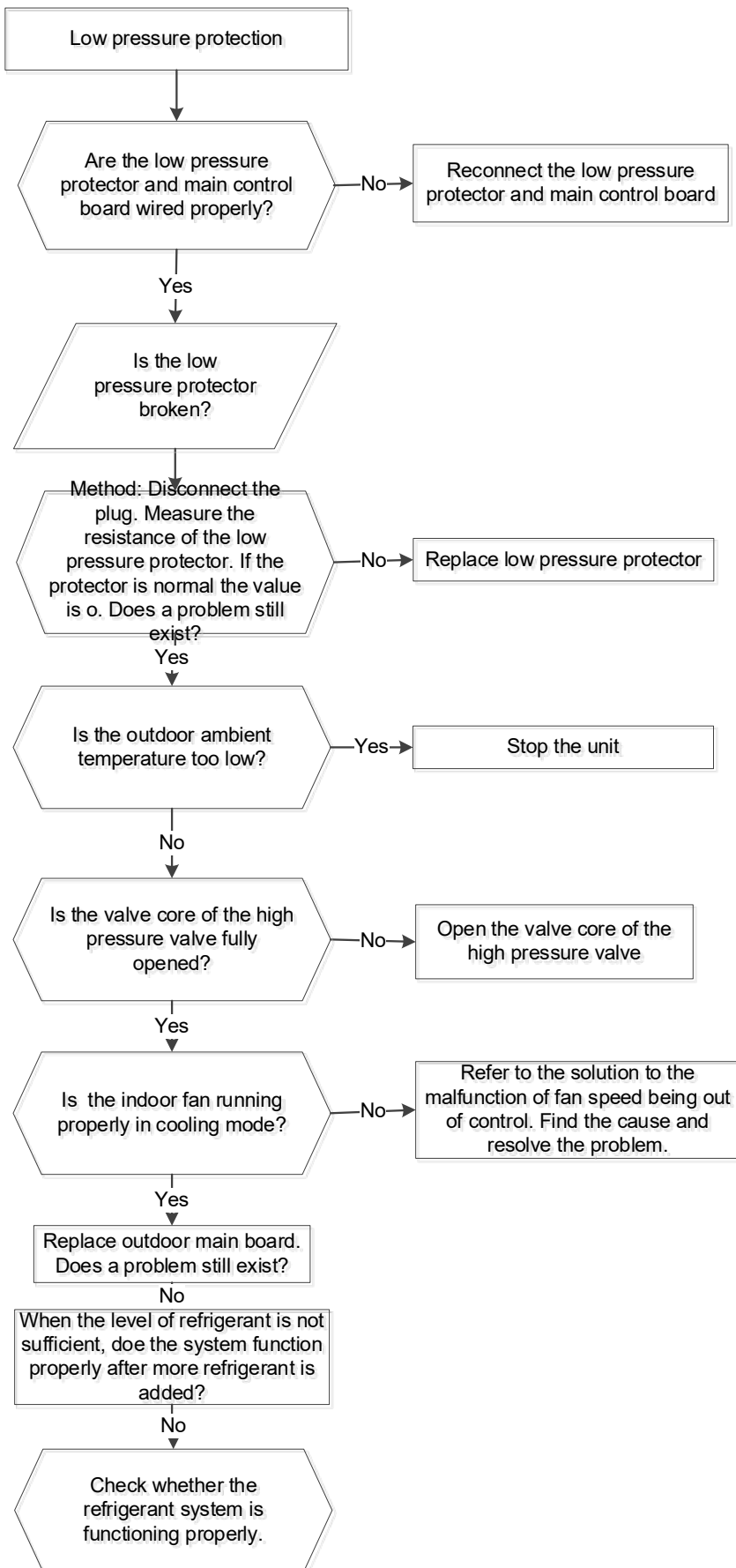

17.4.20. J8 malfunction

Malfunction conditions	An abnormal voltage rise or drop is detected by checking the specified voltage detection circuit.
Supposed causes	<ul style="list-style-type: none"> ● Abnormal power supply ● Wiring mistake ● Faulty bridge rectifier ● Faulty IPM board

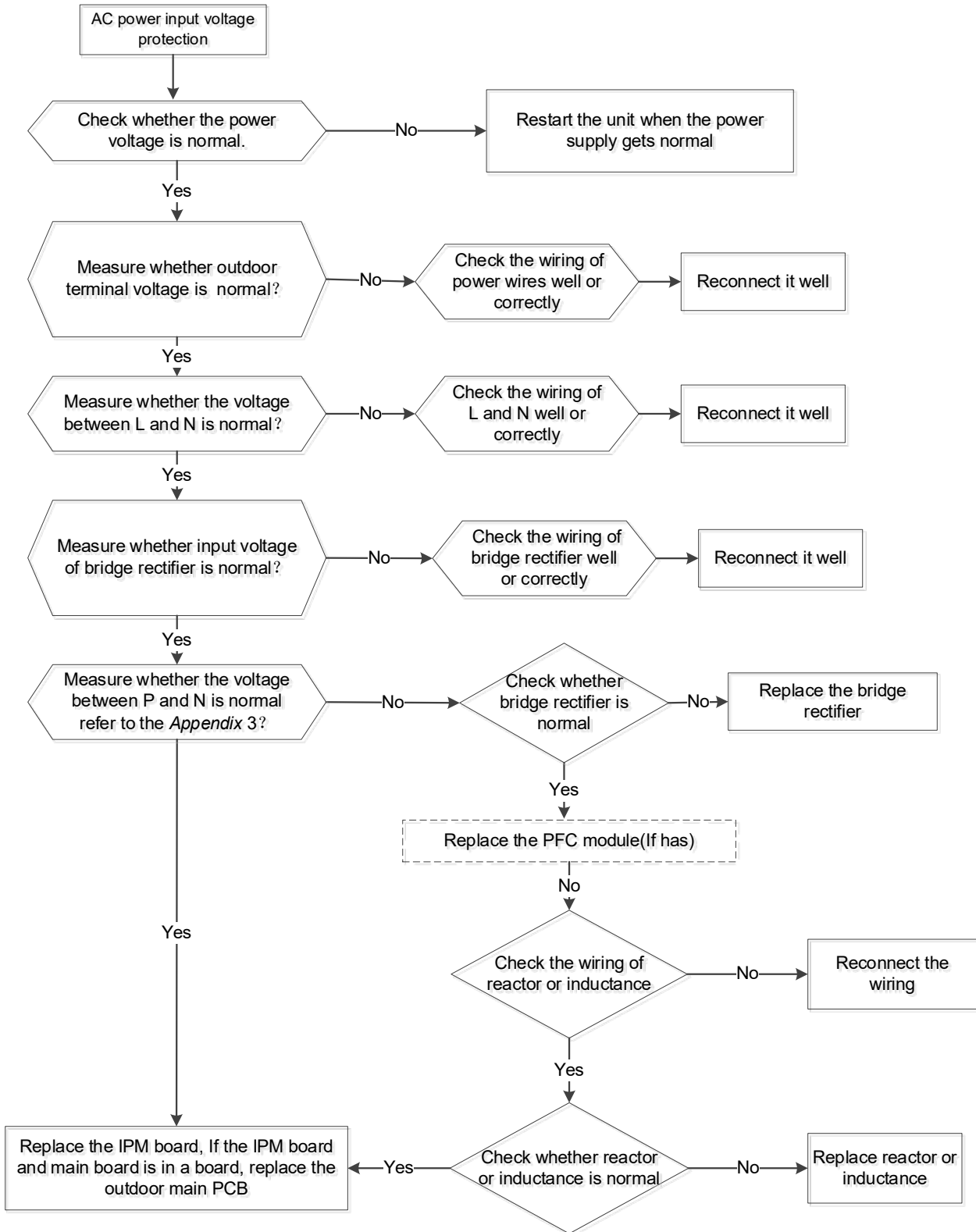

17.4.21 Communication Malfunction between Indoor Unit and auto-lifting Panel (F7)

Malfunction decision conditions	Indoor PCB does not get the feedback from the PCB of auto lifting-panel
Possible causes	<ul style="list-style-type: none"> ● Wiring mistake between indoor PCB and auto-lifting panel ● Faulty PCB of auto-lifting panel ● Faulty indoor PCB

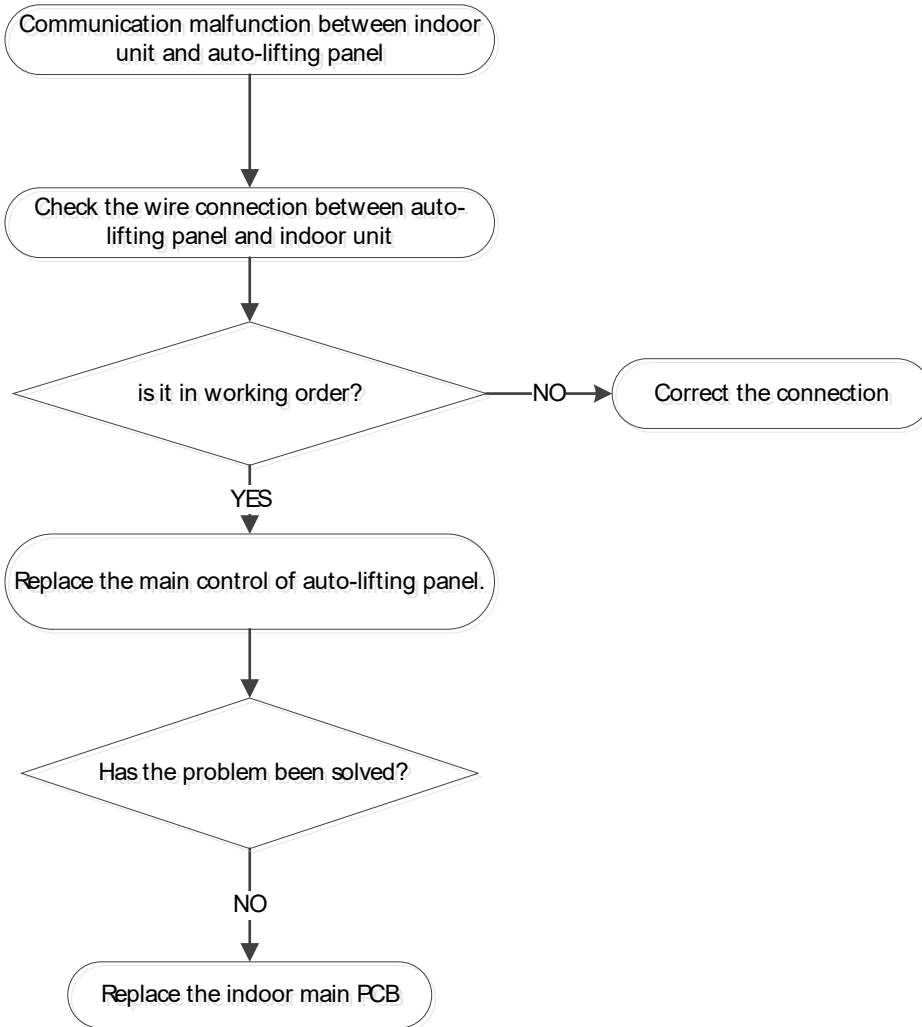

17.4.22 Auto-lifting panel malfunction(F8)

Malfunction decision conditions	Indoor PCB does not get the right close position from the PCB of auto lifting-panel when the panel motor stops
Possible causes	<ul style="list-style-type: none"> ● Wiring mistake between indoor PCB and auto-lifting panel ● Faulty PCB of auto-lifting panel ● Faulty indoor PCB

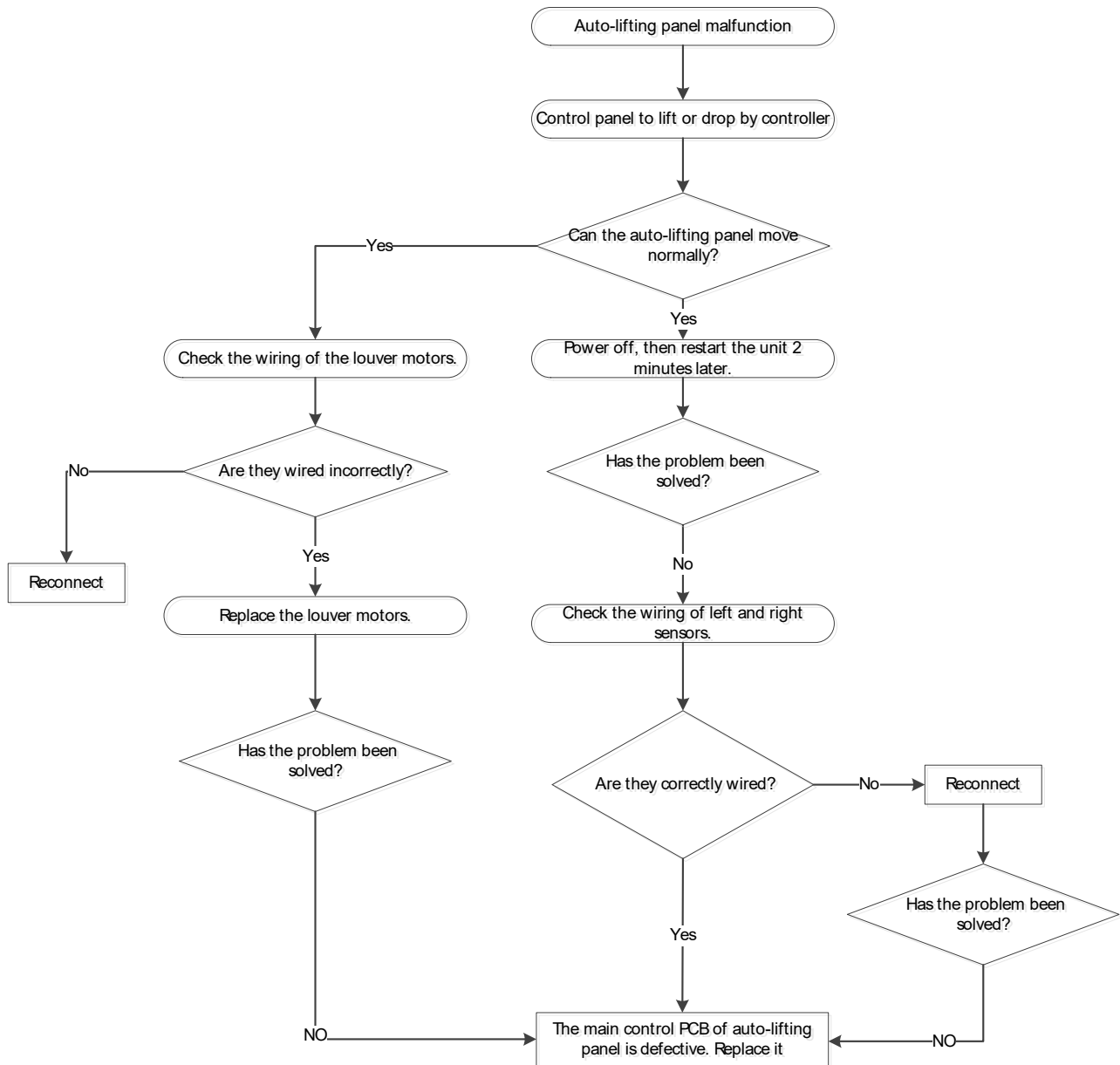

17.4.23 Current overload protection

Error code	F0/ PC 08/ PC 44/PC 46/PC 49
Malfunction decision conditions	If the outdoor current exceeds the current limit value, the LED displays a failure code.
Possible causes	<ul style="list-style-type: none">● Wiring mistakes● Faulty bridge rectifier● System blockages● Faulty outdoor PCB

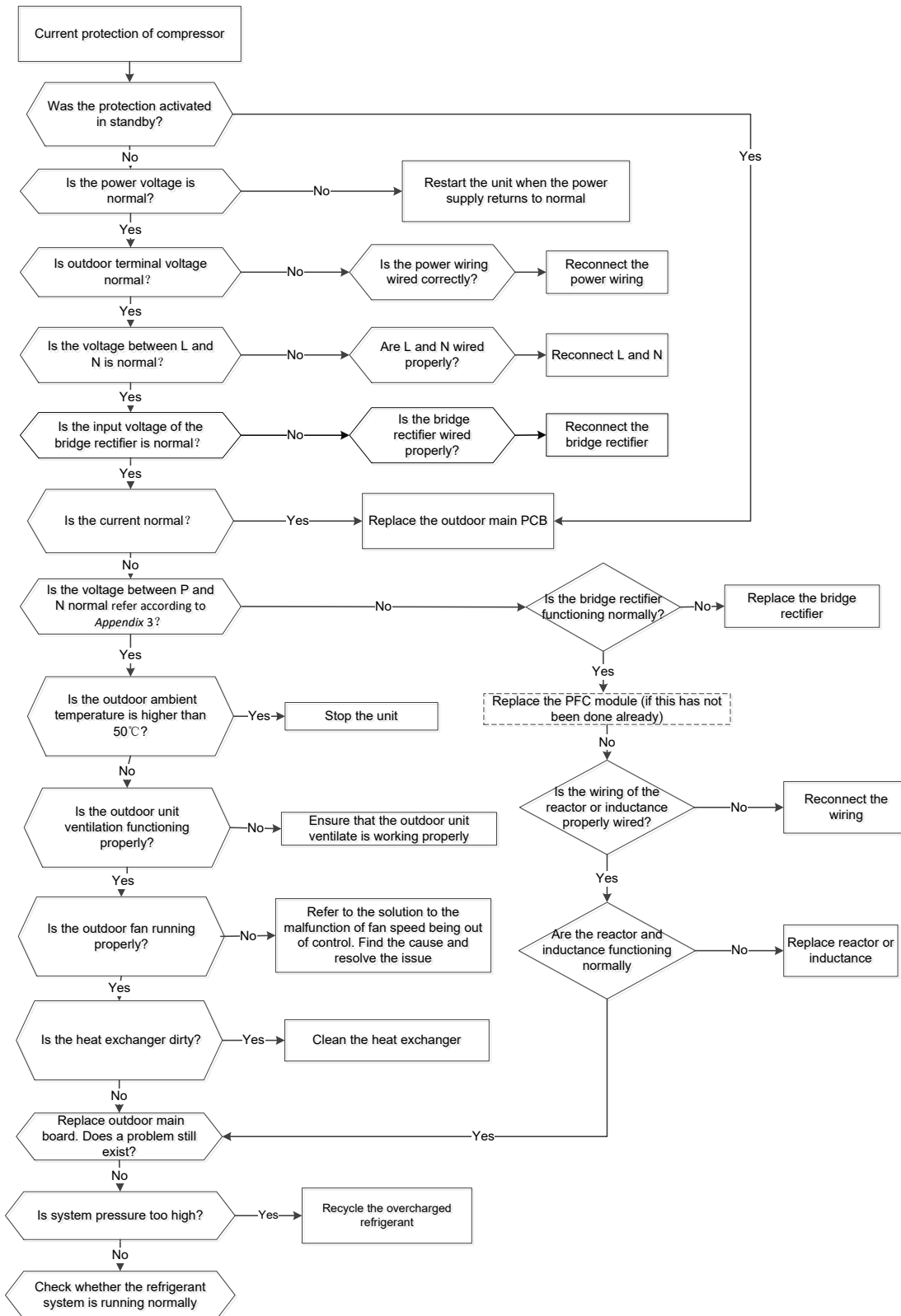

17.4.24 Communication malfunction between indoor two chips diagnosis and solution (FA)

Error Code	FA
Malfunction conditions	Indoor PCB main chip does not receive feedback from another chip.
Potential causes	<ul style="list-style-type: none"> ● Faulty PCB

Trouble shooting:

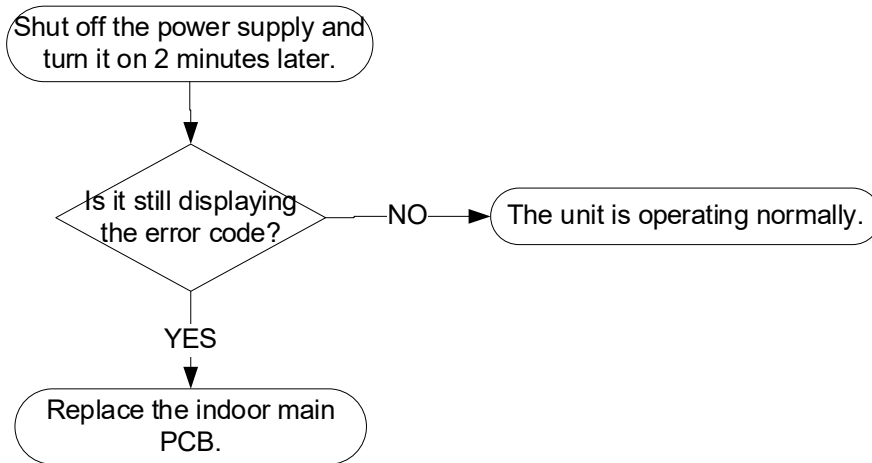

17.4.25 Lack phase failure of outdoor DC fan motor(EC 72)

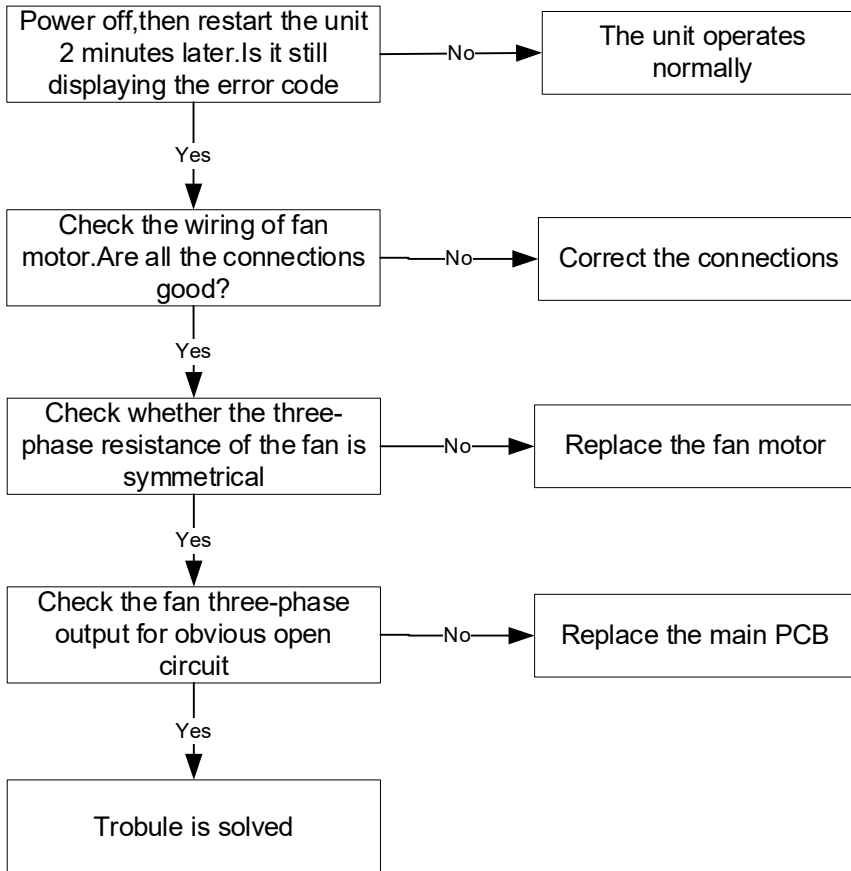

17.4.26 Outdoor compressor lack phase protection(PC 43)

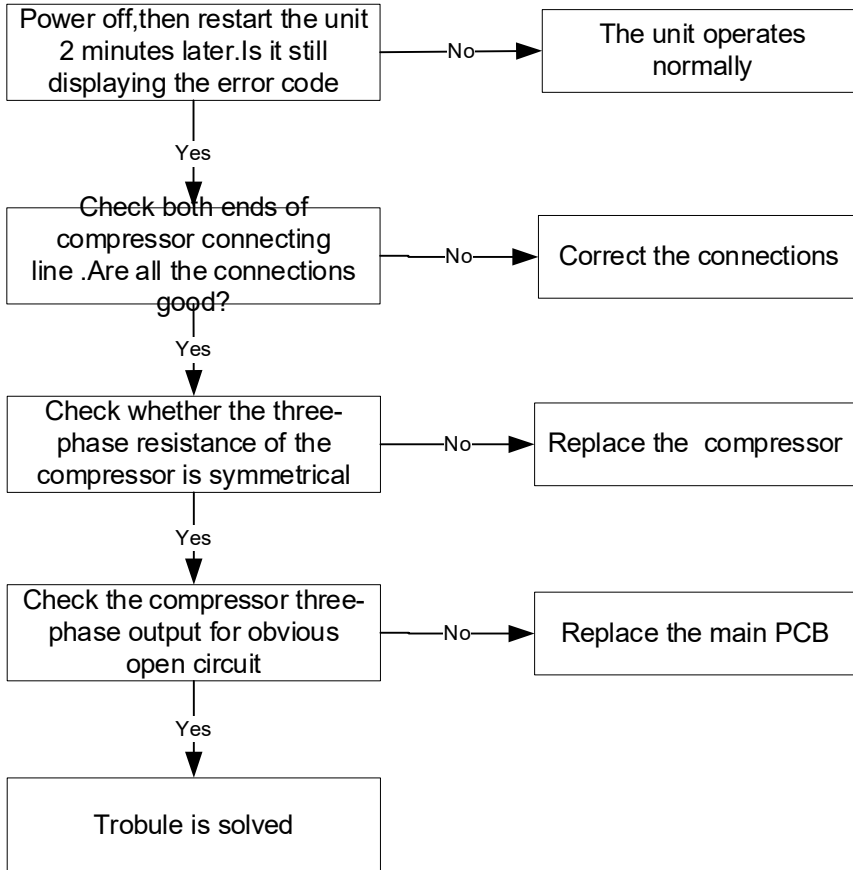

17.4.27 Outdoor unit IR chip drive failure(PC45)

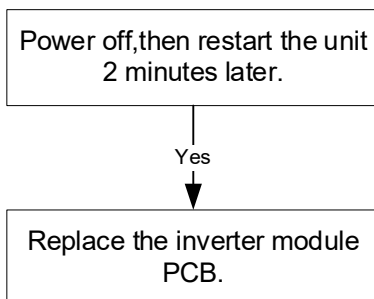

17.5 Main parts check

1. Temperature sensor checking

Disconnect the temperature sensor from PCB, measure the resistance value with a tester.

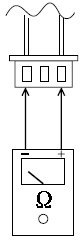

Tester

Temperature Sensors.

Room temp.(T1) sensor,

Indoor coil temp.(T2) sensor,

Outdoor coil temp.(T3) sensor,

Outdoor ambient temp.(T4) sensor,

Compressor discharge temp.(T5) sensor.

Measure the resistance value of each winding by using the multi-meter.

Appendix 1 Temperature Sensor Resistance Value Table for T1,T2,T3,T4 (°C--K)

°C	°F	K Ohm	°C	°F	K Ohm	°C	°F	K Ohm	°C	°F	K Ohm
-20	-4	115.266	20	68	12.6431	60	140	2.35774	100	212	0.62973
-19	-2	108.146	21	70	12.0561	61	142	2.27249	101	214	0.61148
-18	0	101.517	22	72	11.5	62	144	2.19073	102	216	0.59386
-17	1	96.3423	23	73	10.9731	63	145	2.11241	103	217	0.57683
-16	3	89.5865	24	75	10.4736	64	147	2.03732	104	219	0.56038
-15	5	84.219	25	77	10	65	149	1.96532	105	221	0.54448
-14	7	79.311	26	79	9.55074	66	151	1.89627	106	223	0.52912
-13	9	74.536	27	81	9.12445	67	153	1.83003	107	225	0.51426
-12	10	70.1698	28	82	8.71983	68	154	1.76647	108	226	0.49989
-11	12	66.0898	29	84	8.33566	69	156	1.70547	109	228	0.486
-10	14	62.2756	30	86	7.97078	70	158	1.64691	110	230	0.47256
-9	16	58.7079	31	88	7.62411	71	160	1.59068	111	232	0.45957
-8	18	56.3694	32	90	7.29464	72	162	1.53668	112	234	0.44699
-7	19	52.2438	33	91	6.98142	73	163	1.48481	113	235	0.43482
-6	21	49.3161	34	93	6.68355	74	165	1.43498	114	237	0.42304
-5	23	46.5725	35	95	6.40021	75	167	1.38703	115	239	0.41164
-4	25	44	36	97	6.13059	76	169	1.34105	116	241	0.4006
-3	27	41.5878	37	99	5.87359	77	171	1.29078	117	243	0.38991
-2	28	39.8239	38	100	5.62961	78	172	1.25423	118	244	0.37956
-1	30	37.1988	39	102	5.39689	79	174	1.2133	119	246	0.36954
0	32	35.2024	40	104	5.17519	80	176	1.17393	120	248	0.35982
1	34	33.3269	41	106	4.96392	81	178	1.13604	121	250	0.35042
2	36	31.5635	42	108	4.76253	82	180	1.09958	122	252	0.3413
3	37	29.9058	43	109	4.5705	83	181	1.06448	123	253	0.33246
4	39	28.3459	44	111	4.38736	84	183	1.03069	124	255	0.3239
5	41	26.8778	45	113	4.21263	85	185	0.99815	125	257	0.31559
6	43	25.4954	46	115	4.04589	86	187	0.96681	126	259	0.30754
7	45	24.1932	47	117	3.88673	87	189	0.93662	127	261	0.29974
8	46	22.5662	48	118	3.73476	88	190	0.90753	128	262	0.29216
9	48	21.8094	49	120	3.58962	89	192	0.8795	129	264	0.28482
10	50	20.7184	50	122	3.45097	90	194	0.85248	130	266	0.2777
11	52	19.6891	51	124	3.31847	91	196	0.82643	131	268	0.27078
12	54	18.7177	52	126	3.19183	92	198	0.80132	132	270	0.26408
13	55	17.8005	53	127	3.07075	93	199	0.77709	133	271	0.25757
14	57	16.9341	54	129	2.95896	94	201	0.75373	134	273	0.25125
15	59	16.1156	55	131	2.84421	95	203	0.73119	135	275	0.24512
16	61	15.3418	56	133	2.73823	96	205	0.70944	136	277	0.23916
17	63	14.6181	57	135	2.63682	97	207	0.68844	137	279	0.23338
18	64	13.918	58	136	2.53973	98	208	0.66818	138	280	0.22776
19	66	13.2631	59	138	2.44677	99	210	0.64862	139	282	0.22231

Appendix 2 Temperature Sensor Resistance Value Table for T5,TH (°C--K)

°C	°F	K Ohm	°C	°F	K Ohm	°C	°F	K Ohm	°C	°F	K Ohm
-20	-4	542.7	20	68	68.66	60	140	13.59	100	212	3.702
-19	-2	511.9	21	70	65.62	61	142	13.11	101	214	3.595
-18	0	483	22	72	62.73	62	144	12.65	102	216	3.492
-17	1	455.9	23	73	59.98	63	145	12.21	103	217	3.392
-16	3	430.5	24	75	57.37	64	147	11.79	104	219	3.296
-15	5	406.7	25	77	54.89	65	149	11.38	105	221	3.203
-14	7	384.3	26	79	52.53	66	151	10.99	106	223	3.113
-13	9	363.3	27	81	50.28	67	153	10.61	107	225	3.025
-12	10	343.6	28	82	48.14	68	154	10.25	108	226	2.941
-11	12	325.1	29	84	46.11	69	156	9.902	109	228	2.86
-10	14	307.7	30	86	44.17	70	158	9.569	110	230	2.781
-9	16	291.3	31	88	42.33	71	160	9.248	111	232	2.704
-8	18	275.9	32	90	40.57	72	162	8.94	112	234	2.63
-7	19	261.4	33	91	38.89	73	163	8.643	113	235	2.559
-6	21	247.8	34	93	37.3	74	165	8.358	114	237	2.489
-5	23	234.9	35	95	35.78	75	167	8.084	115	239	2.422
-4	25	222.8	36	97	34.32	76	169	7.82	116	241	2.357
-3	27	211.4	37	99	32.94	77	171	7.566	117	243	2.294
-2	28	200.7	38	100	31.62	78	172	7.321	118	244	2.233
-1	30	190.5	39	102	30.36	79	174	7.086	119	246	2.174
0	32	180.9	40	104	29.15	80	176	6.859	120	248	2.117
1	34	171.9	41	106	28	81	178	6.641	121	250	2.061
2	36	163.3	42	108	26.9	82	180	6.43	122	252	2.007
3	37	155.2	43	109	25.86	83	181	6.228	123	253	1.955
4	39	147.6	44	111	24.85	84	183	6.033	124	255	1.905
5	41	140.4	45	113	23.89	85	185	5.844	125	257	1.856
6	43	133.5	46	115	22.89	86	187	5.663	126	259	1.808
7	45	127.1	47	117	22.1	87	189	5.488	127	261	1.762
8	46	121	48	118	21.26	88	190	5.32	128	262	1.717
9	48	115.2	49	120	20.46	89	192	5.157	129	264	1.674
10	50	109.8	50	122	19.69	90	194	5	130	266	1.632
11	52	104.6	51	124	18.96	91	196	4.849			
12	54	99.69	52	126	18.26	92	198	4.703			
13	55	95.05	53	127	17.58	93	199	4.562			
14	57	90.66	54	129	16.94	94	201	4.426			
15	59	86.49	55	131	16.32	95	203	4.294			
16	61	82.54	56	133	15.73	96	205	4.167			
17	63	78.79	57	135	15.16	97	207	4.045			
18	64	75.24	58	136	14.62	98	208	3.927			
19	66	71.86	59	138	14.09	99	210	3.812			

Appendix 3:

°C	10	11	12	13	14	15	16	17	18	19	20	21	22
°F	48	50	52	54	56	58	60	62	64	66	68	70	72
°C	23	24	25	26	27	28	29	30	31	32	33	34	35
°F	74	76	78	80	82	84	86	88	90	92	94	96	98

2. Compressor checking

Measure the resistance value of each winding by using the tester.

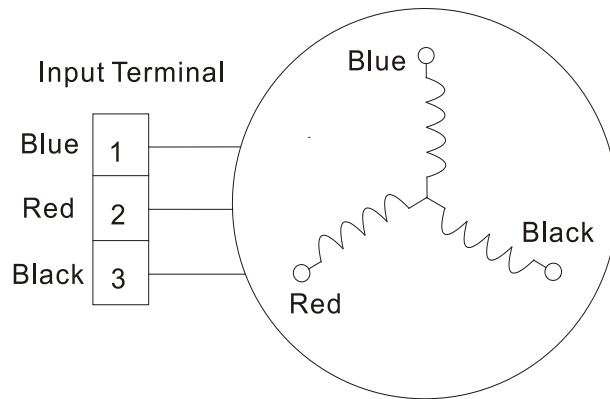

Position	Resistance Value			
	ASN98D22UFZ	ASM135D23UFZ	ATF235D22UMT	ATF250D22UMT
Blue - Red	1.57Ω	1.75 Ω	0.75 Ω	0.75 Ω
Blue - Black				
Red - Blue				
	ATF310D43UMT	ATQ420D1UMU	ATM115D43UFZ2	EAPQ420D1UMUA
Blue - Red	0.65 Ω	0.38Ω	1.87Ω	0.1Ω
Blue - Black				
Red - Blue				



3. IPM continuity check

Turn off the power, let the large capacity electrolytic capacitors discharge completely, and dismount the IPM. Use a digital tester to measure the resistance between P and UVWN; UVW and N.

Digital tester		Normal resistance value	Digital tester		Normal resistance value
(+)Red	(-)Black		(+)Red	(-)Black	
P	N	∞ (Several MΩ)	U	N	∞ (Several MΩ)
	U		V		
	V		W		
	W		(+)Red		

4: Pressure on Service Port

Cooling chart:

COOLING MODE

°F (°C)	Indoor Temp.	Outdoor temp.				
		75 (23.89)	85 (29.44)	95 (35)	105 (40.56)	115 (46.11)
BAR	70	8.2	7.8	8.1	8.6	10.1
BAR	75	8.6	8.3	8.7	9.1	10.7
BAR	80	9.3	8.9	9.1	9.6	11.2

PSI	70	119	113	117	125	147
PSI	75	124	120	126	132	155
PSI	80	135	129	132	140	162

MPA	70	0.82	0.78	0.81	0.86	1.01
MPA	75	0.86	0.83	0.87	0.91	1.07
MPA	80	0.93	0.89	0.91	0.96	1.12

Pressure (bar)

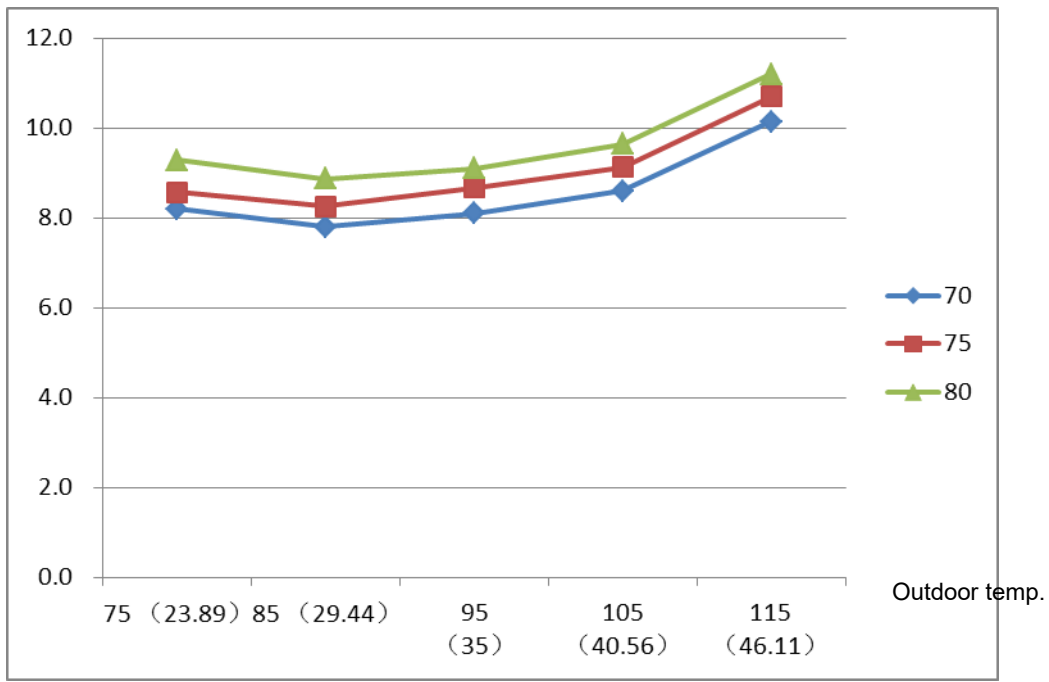

Heating Chart:

HEATING MODE

°F (°C)	Indoor Temp.	Outdoor temp.				
		57 (13.89)	47 (8.33)	37 (2.78)	27 (-2.78)	17 (-8.33)
BAR	55	30.3	28.5	25.3	22.8	20.8
BAR	65	32.5	30.0	26.6	25.4	23.3
BAR	75	33.8	31.5	27.8	26.3	24.9

PSI	55	439	413	367	330	302
PSI	65	471	435	386	368	339
PSI	75	489	457	403	381	362

MPA	55	3.03	2.85	2.53	2.28	2.08
MPA	65	3.25	3.00	2.66	2.54	2.33
MPA	75	3.38	3.15	2.78	2.63	2.49

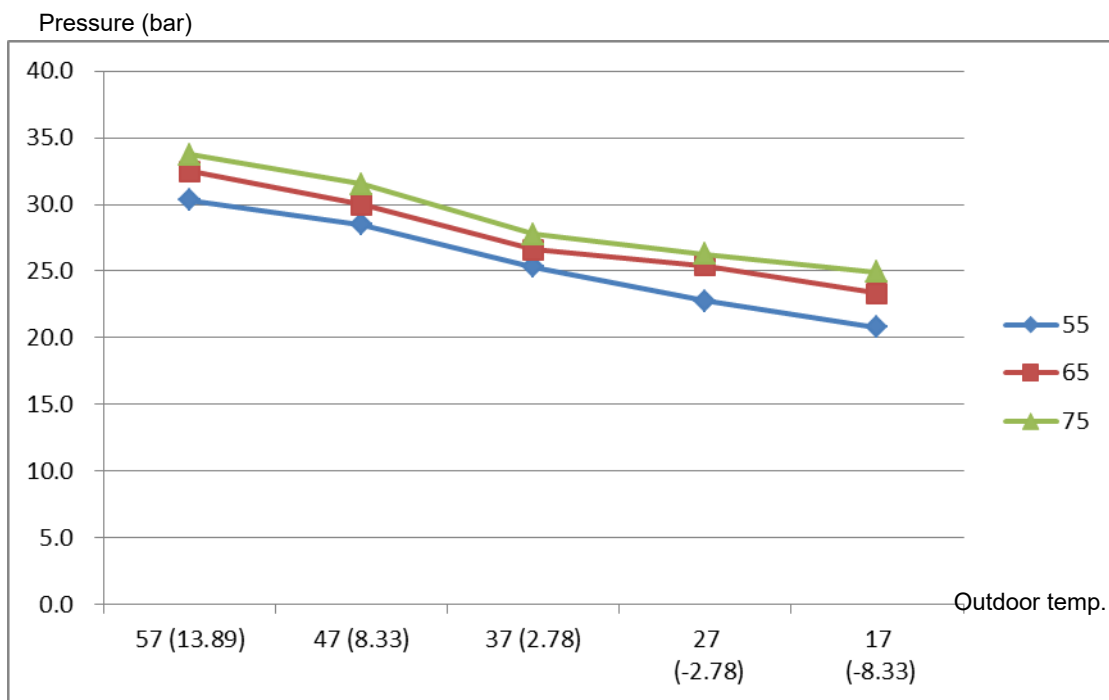



18. Disassembly Instructions



Note: This part is for reference, the photos may have slight difference with your machine.

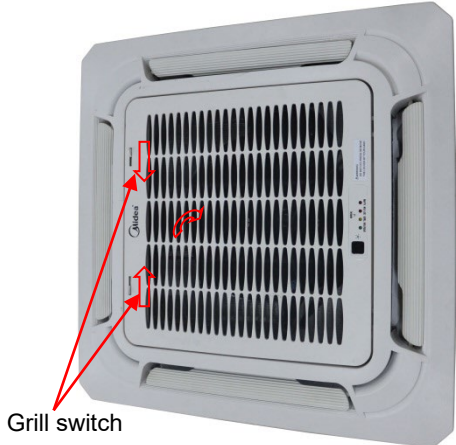

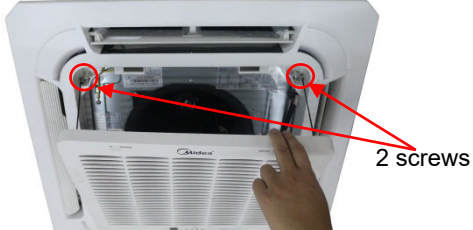
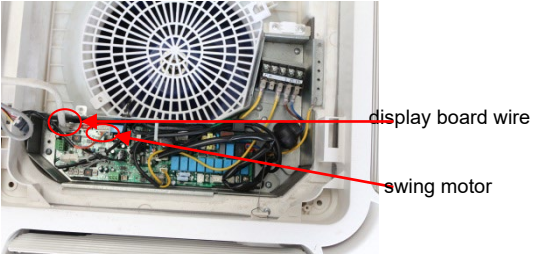
18.1 Indoor unit

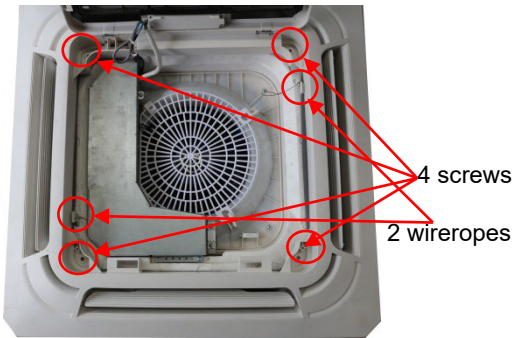
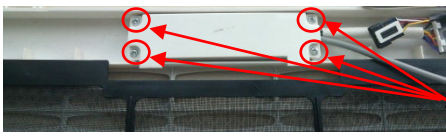
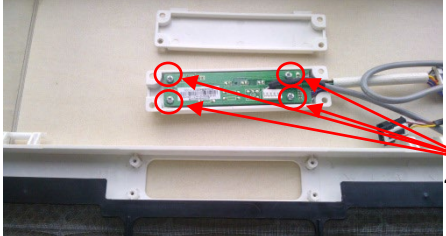
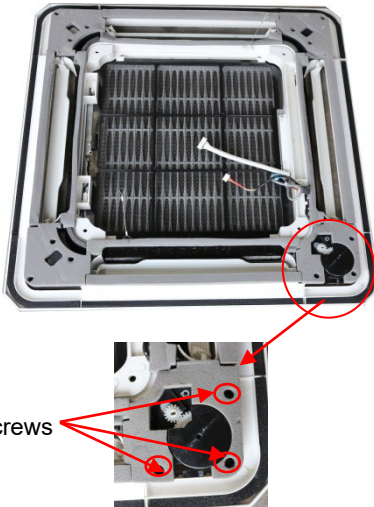
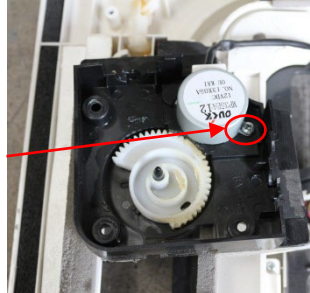

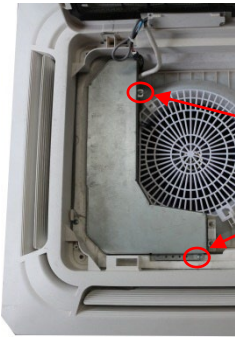
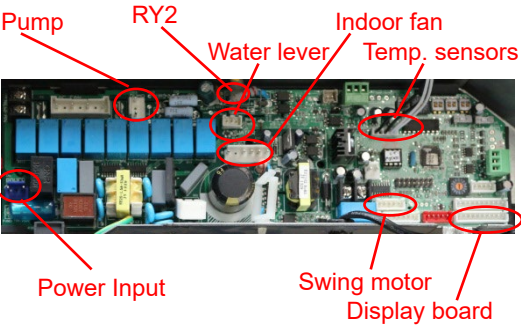
➤ Cassette Unit

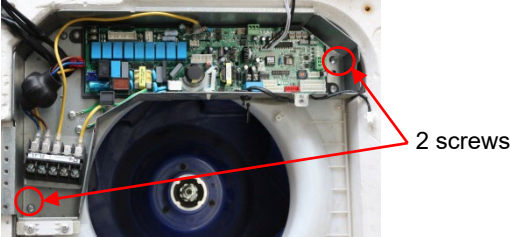

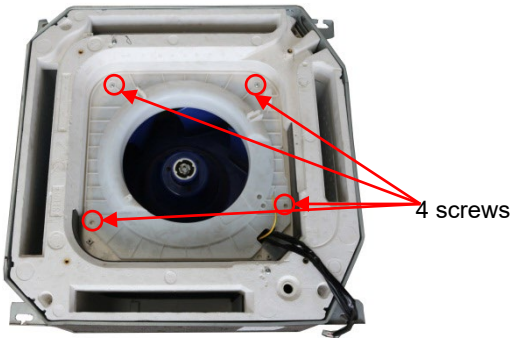
No.	Parts name	Procedures	Remarks
1	Remove the filter	1) Open the grille	 <p>Grill switch</p>
		2) Remove the filter Note: the filter is easy to be damaged, be careful when removing it.	
2	Remove the panel	1) Open the grille	Repeat the operation of step1 of No.1
		2) Remove the grille <ul style="list-style-type: none"> ● Screw off two screws. ● Disconnect the display board wire and swing motor wire connected to the PCB. ● Remove the grille. 	 <p>2 screws</p>  <p>display board wire swing motor</p>

		<p>3) Loose the four screws and two wireropes, then the panel can be disassembled.</p>	 <p>4 screws 2 wireropes</p>
3	Remove the display board	1) Open the grille	Repeat the operation of step1 of No.1
		2) Remove the grille	Repeat the operation of step2 of No.2
		<p>3) Disassemble the display board</p> <ul style="list-style-type: none"> ● Remove the display board cover(4 screws) ● Remove the display board(4 screws) 	 <p>4 screws</p>  <p>4 screws</p>
4	Remove the swing motor	1) Remove the panel	Repeat the operation of step1,2,3 of No.2
		2) Screw off 3 screws to remove the swing motor assy.	 <p>3 screws</p>
		3) Screw off 1 screws to remove the swing motor.	 <p>1 screw</p>
5	Remove the PCB	1) Open the grille	Repeat the operation of step1 of No.1(No need to remove the panel)

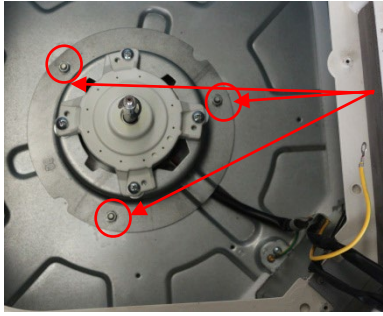
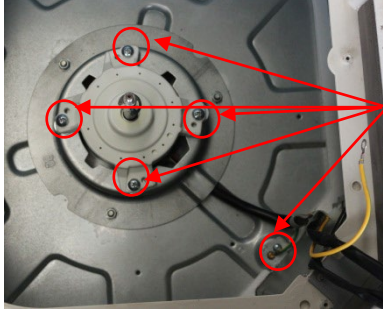
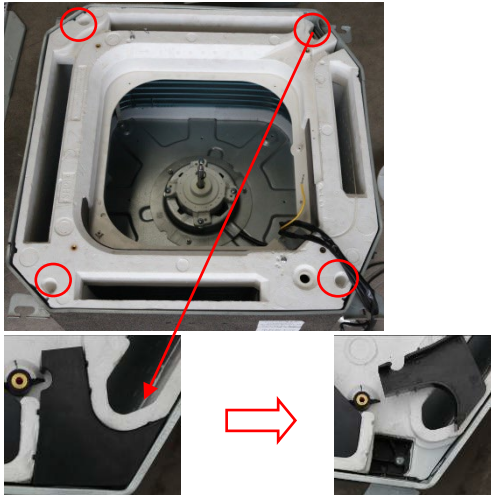
		<p>2) Disassemble the electronic control box cover after remove the 2 screws.</p>	
		<p>3) Pull out all the connection wires to other parts, then the PCB can be replaced.</p>	
		<p>4) There are 2 buckles fixing the PCB. To draw out the PCB, you should open them.</p>	
<p>6</p>	<p>Remove the electronic control box</p>	<p>1) Open the grille</p>	<p>Repeat the operation of step1 of No.1(No need to take down the panel)</p>
		<p>2) Remove the electronic control box cover</p>	<p>Repeat the operation of step 2 of No.5</p>
		<p>3) Pull out all the plugs or connectors connected to the electronic control box</p>	
		<p>4) Remove the electronic control box Remove the 2 screws to disassemble the electronic control box</p>	

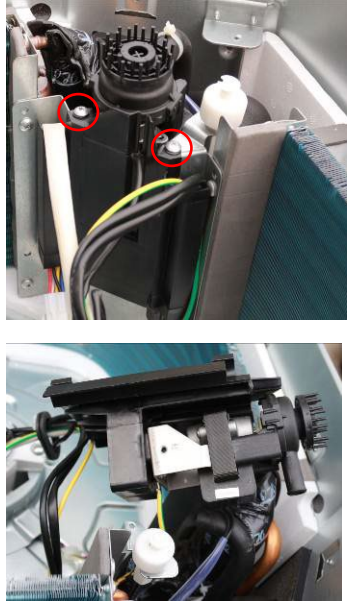

			
7	Remover the fan wheel	1) Repeat the operation of No.5	
		2) Remove the ventilation ring Release the 4 screws to disassemble it.	
		3) Remove the fixing nut to disassemble the fan wheel	
		4) Pull out the fan wheel	
8	Remove the fan motor	1) Repeat the operation of No.6	

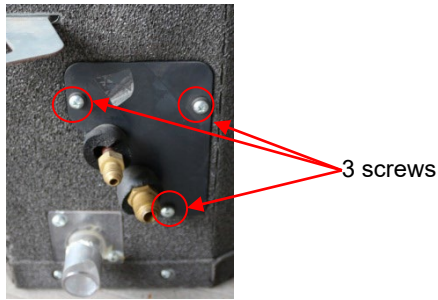
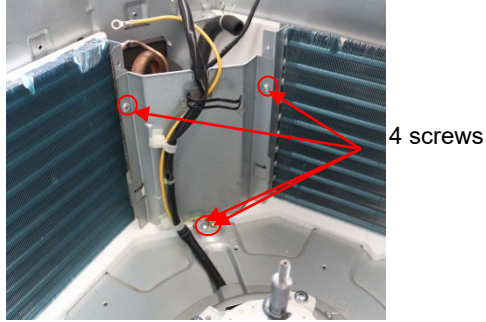

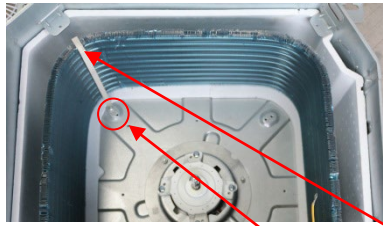

		2) Remove the fixing board of fan motor wire	
		3) Remove the 5 screws to disassemble the fan motor	
9	Remove the water collecting assembly	1) Remove the panel	Repeat the operation of No.2
		2) Remove the electronic control box	Repeat the operation of No.6
		3) Screw off the 4 screws inside 4 holes (1 is under a protection cover) to remove the water collecting assembly.	
		4) Take out the water collecting assembly	
10	Remove the draining pump	1) Remove the panel	Repeat the operation of No.2
		2) Remove the electronic control box	Repeat the operation of No.6
		3) Remove the water collecting assembly	Repeat the operation of No.9

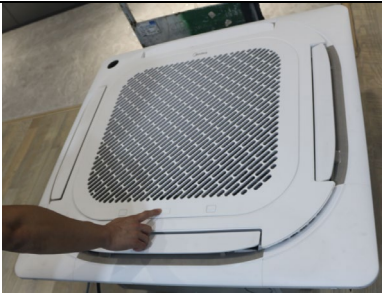
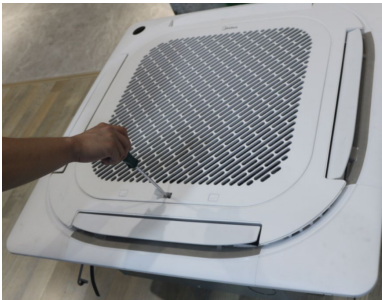
		<p>4) Disconnect the drain pipe.</p>	
		<p>5) Release 2 screws to remove the pump supporter. Be careful of the connection wires.</p>	
		<p>6) There are 2 screws under the supporter to fixing the pump. Release them to take the pump out of the supporter.</p>	
<p>11</p>	<p>Remove the evaporator</p>	<p>1) Remove the water collecting assembly</p>	<p>Repeat the operation of No.9</p>
		<p>2) Remove the seal board of evaporator</p>	
		<p>3) Remove the evaporator fixing board</p>	



		<p>4) Remove the evaporator fixing clamps to disassemble the evaporator.</p>	 <p>1 screw</p> <p>Fixing clamps</p>
--	--	--	--

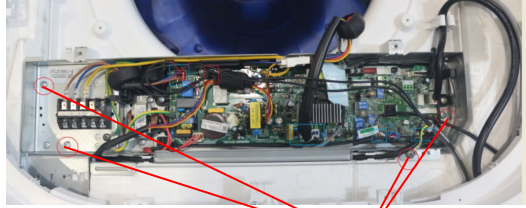
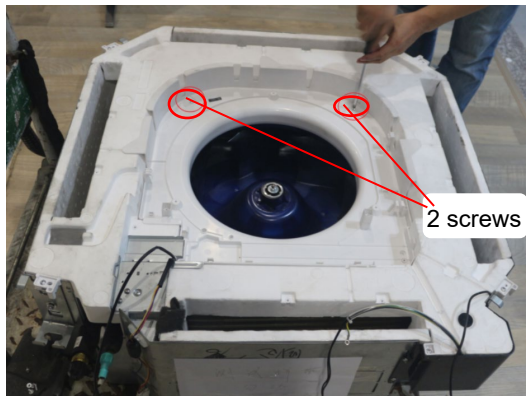
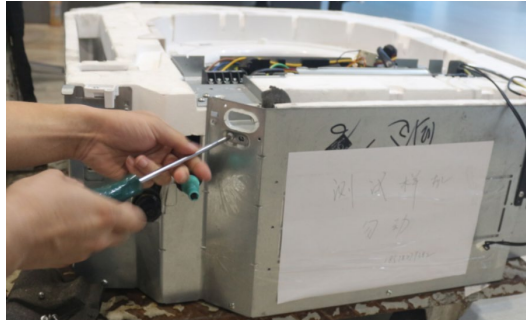
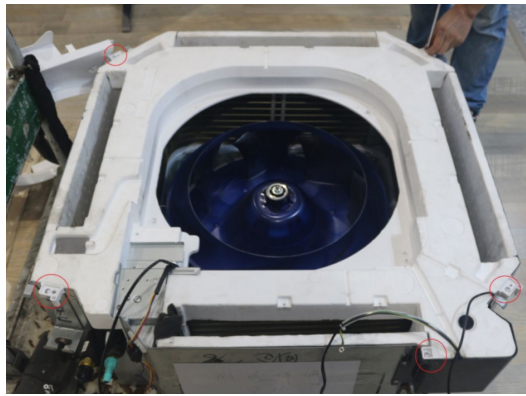

➤ **New Cassette Unit()**

No.	Parts name	Procedures	Remarks
1	Remove the filter	<p>1) Push one side of the grille clamp</p>	
		<p>2) Remove one screw then push two grille clamps to remove the air inlet grille assembly</p>	 
		<p>3) Turn over the air inlet grille assembly then pull up the filter. Note: the filter is easy to be damaged, be careful when removing it.</p>	
2	Remove the	1) Open the grille	Repeat the operation of step1&2 of No.1

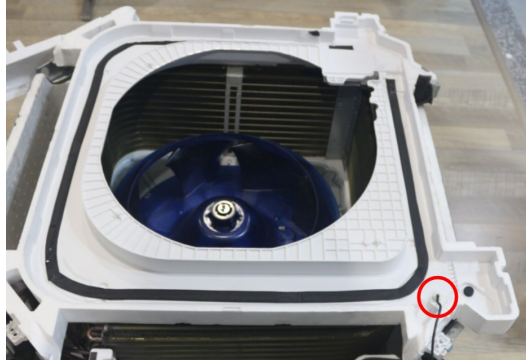
	display board	<p>2) Disassemble the display board</p> <ul style="list-style-type: none"> ● Open the install cover assembly(with display board) ● Remove 1 screw of display window board. ● Turn over the display board, push the switch to remove the display board. 	
3	Remove the PCB	<p>1) Open the grille</p>	Repeat the operation of step1&2 of No.1(No need to remove the panel)
		<p>2) Disassemble the electronic control box cover after remove the 2 screws.</p>	 <p style="text-align: center;">2 screws</p>
		<p>3) Pull out all the connection wires to other parts, then the PCB can be replaced.</p>	 <p style="text-align: center;">Pump Temp. sensors Water lever Fan motor</p>
		<p>4) Remove 2 screws of the main control board and 2 screws of earth wire.</p>	 <p style="text-align: center;">2 screws of earth wire</p>
4	Remove the electronic control box	<p>1) Open the grille</p>	Repeat the operation of step1&2 of No.1(No need to take down the panel)
		<p>2) Remove the electronic control box cover</p>	Repeat the operation of step 2 of No.3

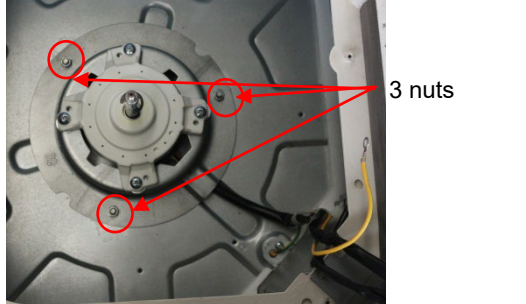
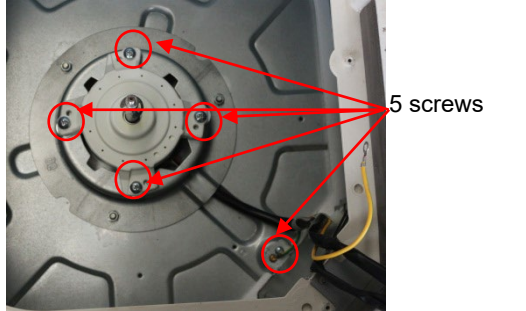

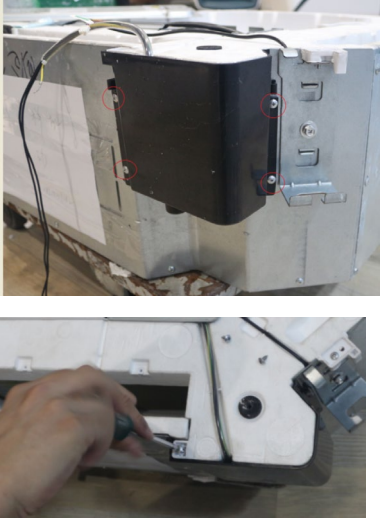
		<p>3) Pull out all the plugs or connectors connected to the electronic control box</p>	
		<p>4) Remove the electronic control box Remove 3 screws of electronic control box and 1 screw of earth wire.</p>	 <p>4 screws</p>
<p>5</p>	<p>Remover the fan wheel</p>	<p>1) Repeat the operation of No.4</p>	
		<p>2) Remove the ventilation ring Release the 2 screws to disassemble it.</p>	 <p>2 screws</p>
		<p>3) Remove the 2 screws fixing the water collector</p>	
		<p>4) Remove the 5 screws of the water collector subassembly.</p>	

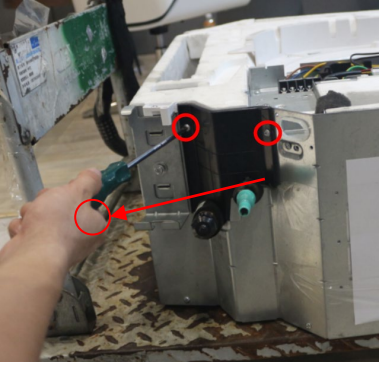
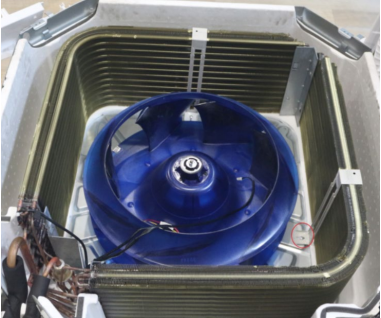
		<p>5) Turn over the water collector subassembly and remove the water level switch.</p>	
		<p>6) Remove the fixing nut to disassemble the fan wheel</p>	
		<p>7) Pull out the fan wheel</p>	
<p>6</p>	<p>Remove the fan motor</p>	<p>1) Repeat the operation of No.5</p>	
		<p>2) Remove the fixing board of fan motor wire</p>	
		<p>3) Remove the 5 screws to disassemble the fan motor</p>	
<p>7</p>	<p>Remove the</p>	<p>1) Remove the panel</p>	<p>Repeat the operation of No.1</p>

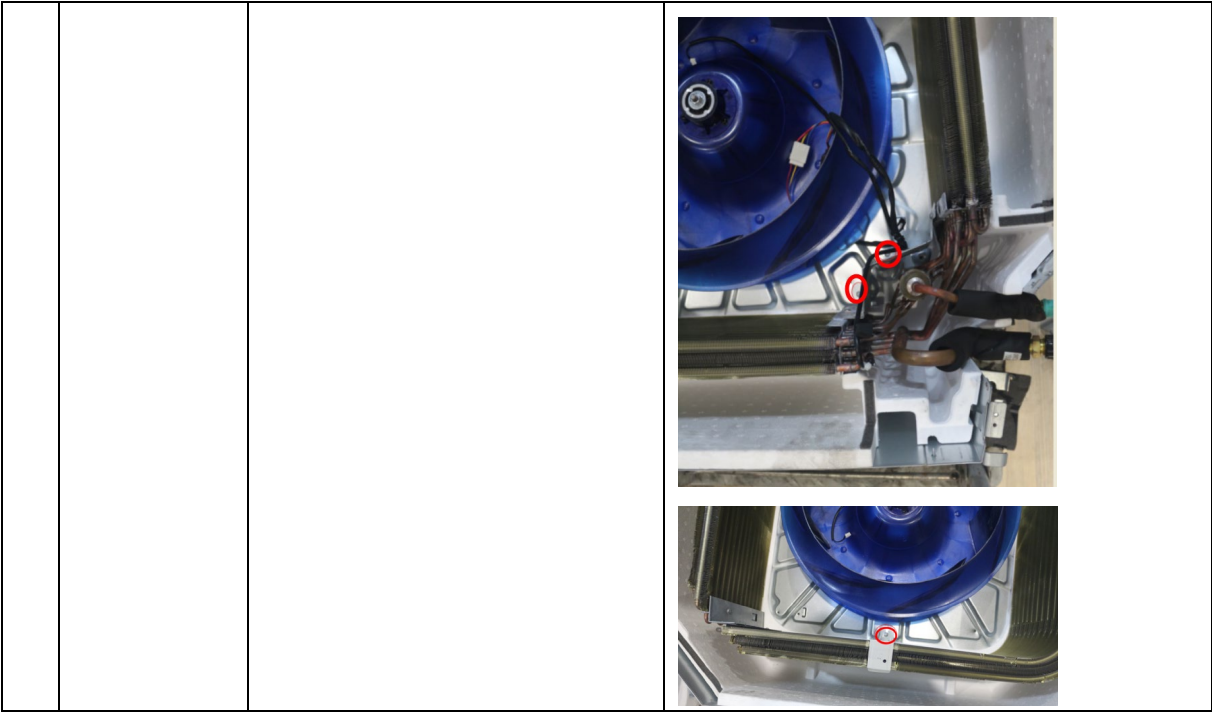

	draining pump	2) Remove 5 screws fixing external water pump box assembly	
		3) Remove the water pump box assembly.	
8	Remove the evaporator	1) Remove the water collecting assembly	Repeat the operation of step 1~4 of No.6
		2) Remove the seal board of evaporator(2 screws)	
		3) Remove the evaporator fixing board(4 screws)	

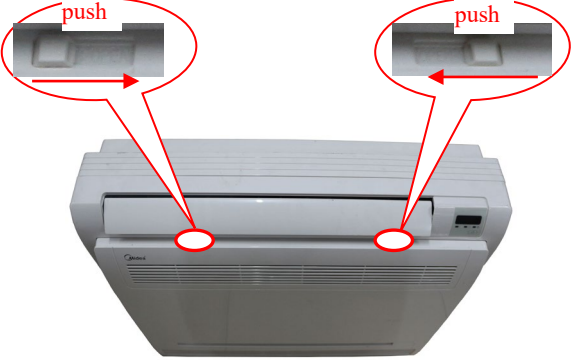

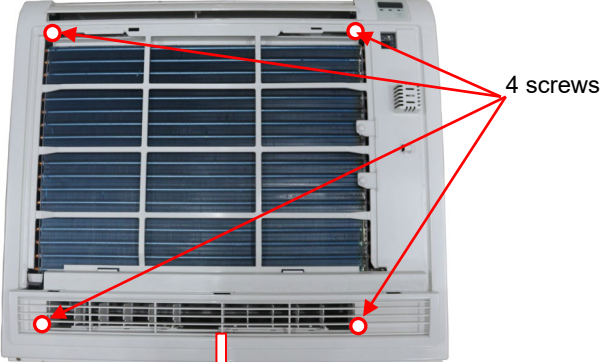

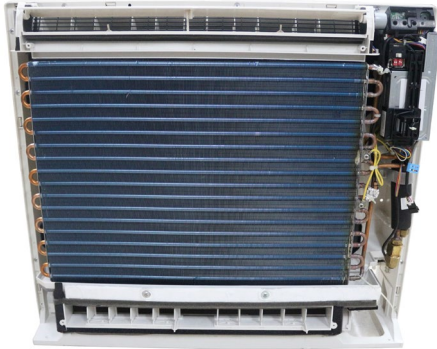
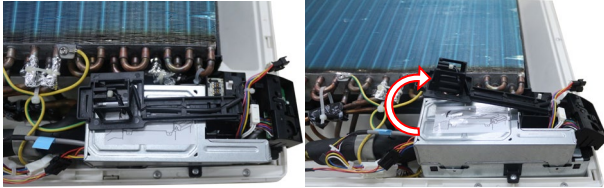
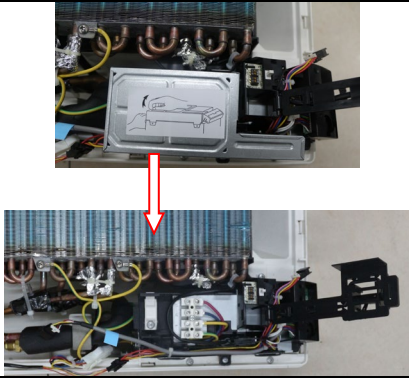
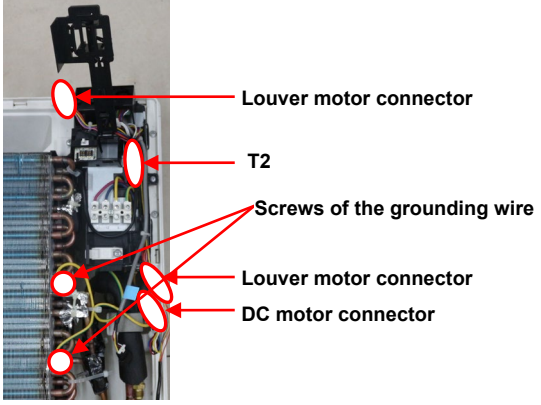

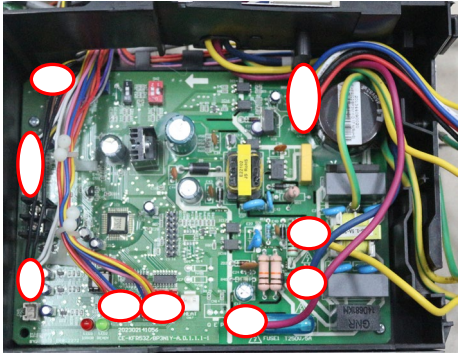
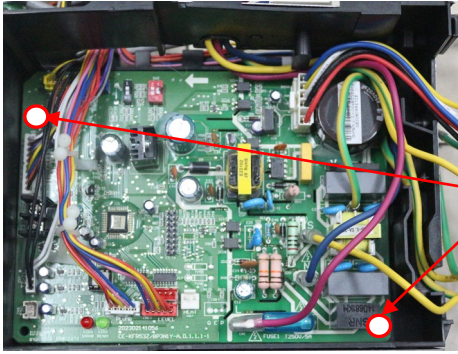

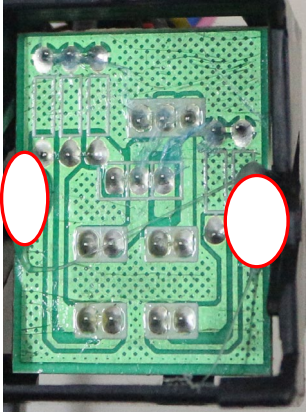
➤ Console Unit

No.	Parts name	Procedures	Remarks
1	Remove the Filter	1) Slide the two stoppers on the left and right sides to open the front panel	
		2) Remove the filter.	
2	Remove the electronic control box	1) Remove the air front panel	<ul style="list-style-type: none"> ● Open the front panel Repeat the operation of step1 of No.1
			<ul style="list-style-type: none"> ● Remove the string.  <ul style="list-style-type: none"> ● Allowing the front panel to fall forward will enable you to remove it.
		2) Remove the filter.	Repeat the operation of step 2 of No. 1
		3) Remove four fixing screws to remove the panel frame assembly	

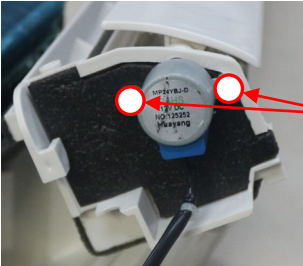
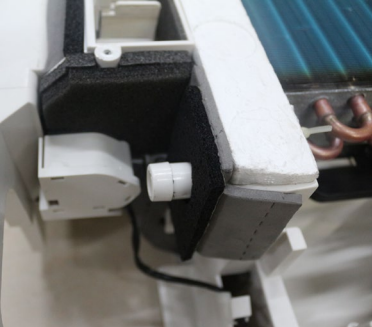
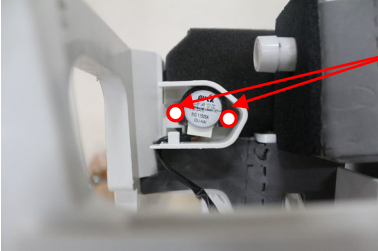
			
		<p>4) Remove the installation plate of electric parts</p>	
		<p>5) Remove the fixing board of electronic control box</p>	
		<p>6) Disconnect the DC motor wire, 2 louver motor wires, evaporator coil temperature sensor(T2) wire, and two grounding wire (yellow-green) to remove the electronic control box</p>	
<p>3</p>	<p>Remove the PCB</p>	<p>1) Take out the electronic control box from the body and remove its cover</p>	<p>Repeat the operation of step1~ step6 of No2.</p>

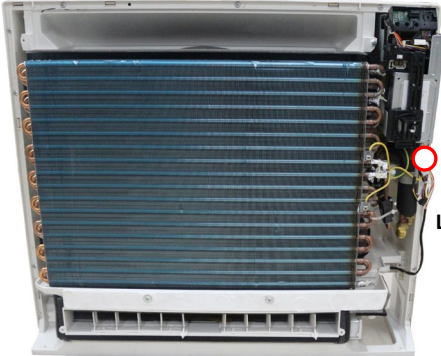
		<p>2) Disconnect all the wires of plugs connected to the PCB</p>	
		<p>3) Remove two fixing screws to remove the PCB</p>	 <p>2 screws</p>
<p>4.</p>	<p>Remove the display board</p>	<p>1) Remove the electronic control box</p>	<p>Repeat the operation of step1~step of No2.</p>
		<p>2) Remove the fixing glue to remove the display board</p>	
<p>5</p>	<p>Remove the switch board</p>	<p>1) Remove the electronic control box</p>	<p>Repeat the operation of step1~step of No2.</p>
		<p>2) Remove the fixing glue to remove the display board</p>	
<p>7</p>	<p>Remove the air outlet grille assembly</p>	<p>1) Remove the front panel assembly and the panel frame assembly</p>	<p>Repeat the operation of step1, step2 and step3 of No 2.</p>

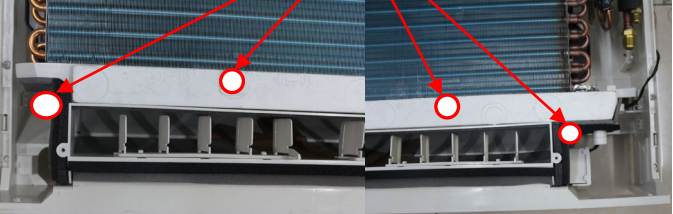
		2) Remove the 1 fixing screw to remove air outlet grille assembly	
		3) Disconnect louver motor wire	
8	Remove the louver motor of air outlet assembly	1) Remove the air outlet grille assembly	Repeat the operation of No.7 to remove the air outlet grille assembly
		2) Screw off the screws to remove the motor	
9	Remove the louver motor of the water collector	1) Remove the front panel assembly and the panel frame assembly	Repeat the operation of step1, step2 and step3 of No 2.
		2) Remove the cover of louver motor	
		3) Screw off the screws to remove the motor	
10	Remove the water collector	1) Remove the front panel assembly and the panel frame assembly	Repeat the operation of step1, step2 and step3 of No 2.

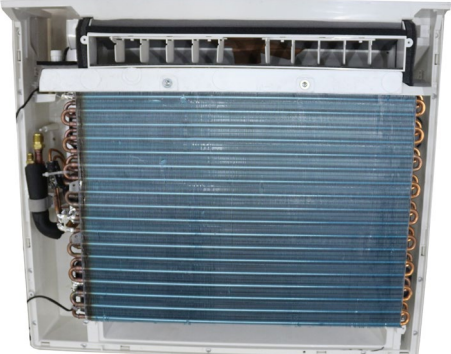
		<p>2) Disconnect louver motor wire</p>	 <p>Louver motor connector</p>
		<p>3) Remove 4 fixing screws to disassemble the water collector</p>	 <p>4 screws</p>  
<p>11</p>	<p>Remove the evaporator assembly</p>	<p>1) Remove the electronic control box</p>	<p>Repeat the operation of No.2 to remove the electronic control box</p>
		<p>2) Remove the air outlet grille assembly</p>	<p>Repeat the operation of No.7 to remove the air outlet grille assembly</p>
		<p>3) Remove the evaporator sensor and release the pipe strap.</p>	
		<p>4) Remove the evaporator assembly</p>	

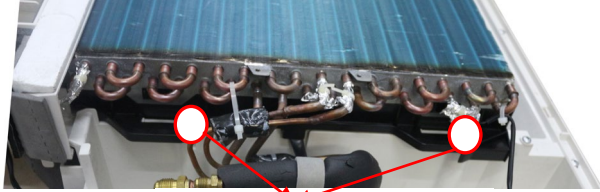
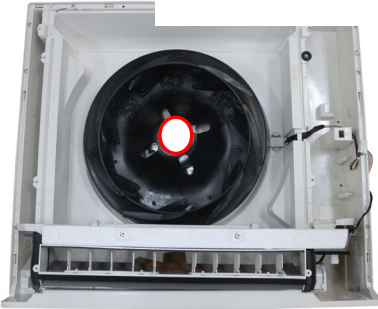
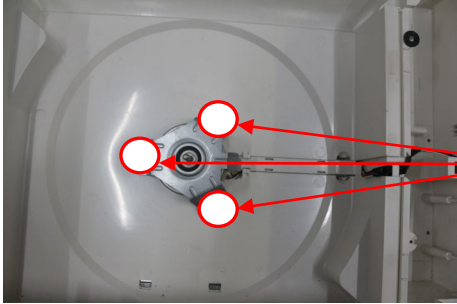

12	Remove the centrifugal fan	1) Remove the electronic control box	Repeat the operation of No.2 to remove the electronic control box
		2) Remove the air outlet grille assembly	Repeat the operation of No.7 to remove the air outlet grille assembly
		3) Remove four fixing screws to remove the ventilation assembly	 <p>Each side has two screws</p>
		4) Remove the hex nut fixing the fan to remove the fan.	
13	Remove the fan motor	5) Remove the centrifugal fan	Repeat the operation of No.12 to remove the centrifugal fan
		6) Remove the fan motor after unfastening three fixing screws.	 <p>3 screws</p>

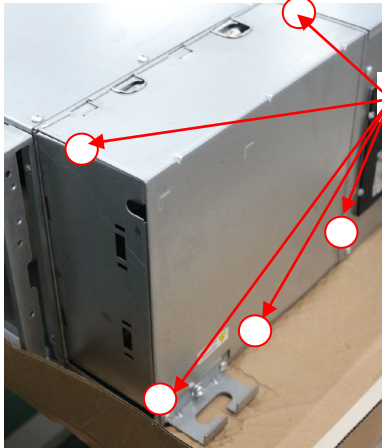
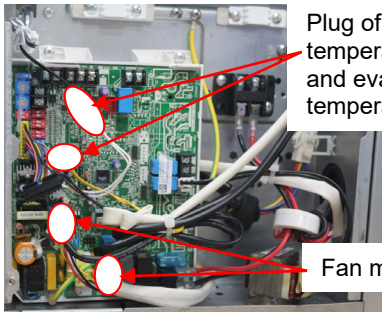
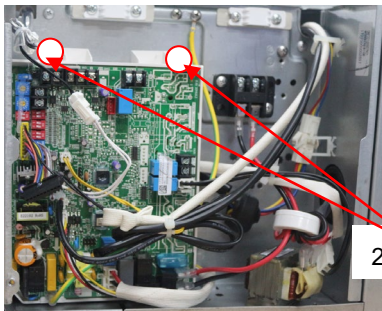
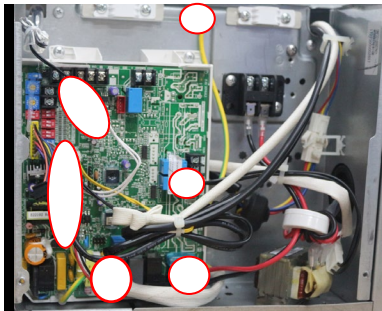
➤ **FPA Duct Unit**

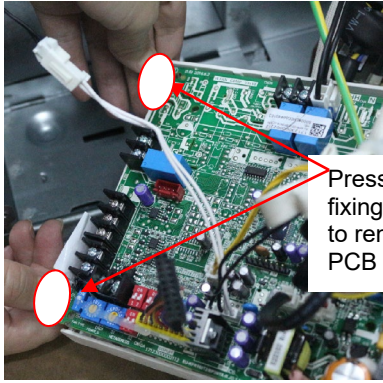
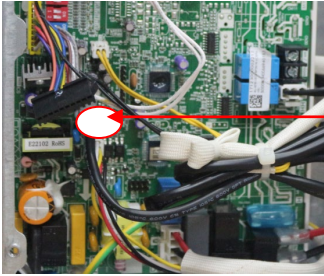
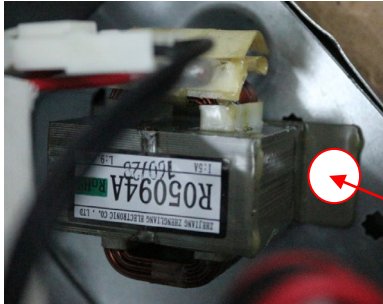
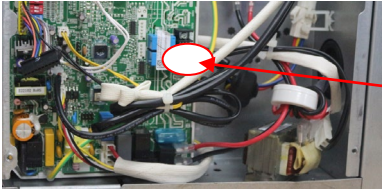
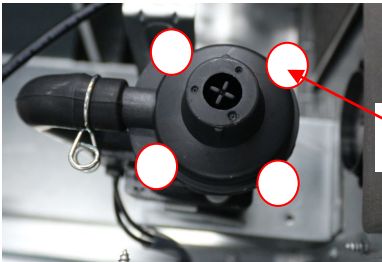
No.	Parts name	Procedures	Remarks
1	Remove the electronic control box	3) Screw off the screws to remove the cover of electronic control box	 <p>Five screws</p>
		4) Disconnect the fan motor wire, room temperature sensor wire and evaporator temperature sensor wire	 <p>Plug of room temperate sensor and evaporator temperature sensor</p> <p>Fan motor wire</p>
		5) Screw off the screws to remove electronic control box	 <p>2 screws</p>
2	Remove the PCB	4) Remove the cover of electronic control box	Repeat the operation of step1 of No1
		1) Pull out all the plugs or connectors connected to the PCB and remove the ground wire after remove the screw.	

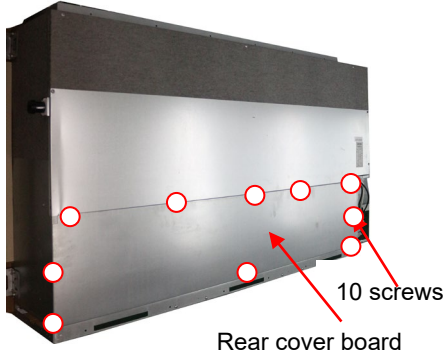
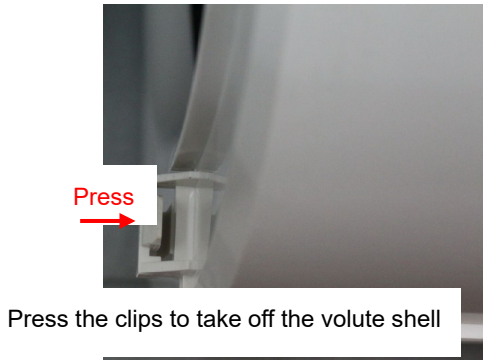
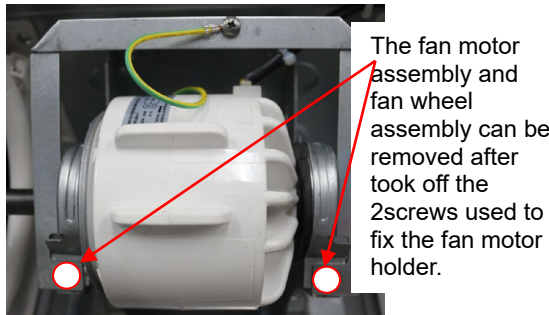
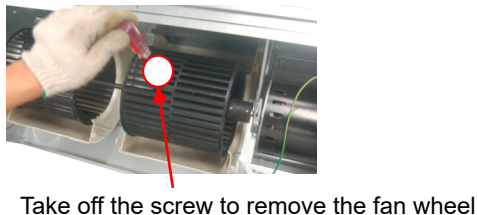
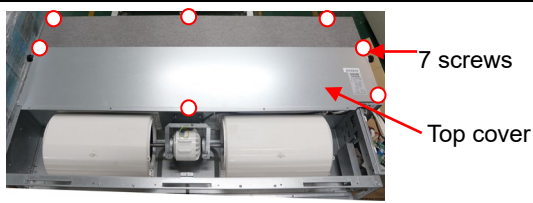
		5) Remove the PCB from the electronic control box	 <p>Press the two fixing holders to remove the PCB</p>
3**	Remove the reactance	1) Remove the cover of electronic control box	Repeat the operation of step1 of No1
		2) Disconnect the reactance wire	 <p>Reactance wire</p>
		3) Screw off the screw to remove it	 <p>1 screw</p>
4**	Remove the drain pump	1) Remove the cover of electronic control box	Repeat the operation of step1 of No1
		2) Disconnect the drain pump wire	 <p>Drain pump wire</p>
		3) Screw off the screws to remove it	 <p>4 screws</p>

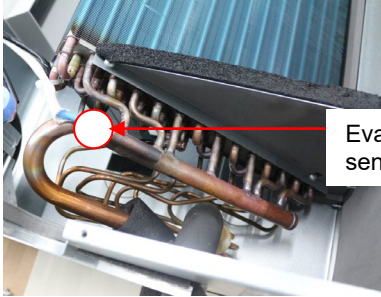
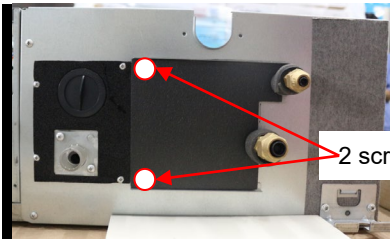
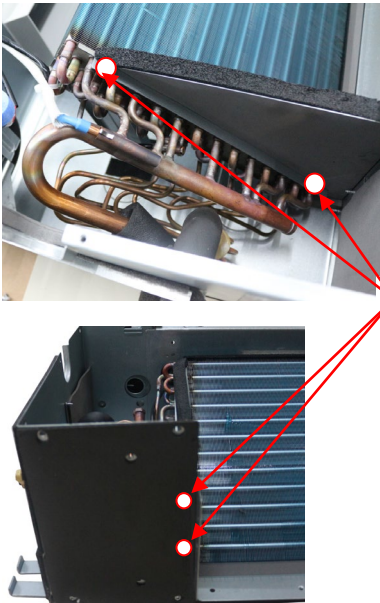
5	Remover the fan motor	1) Screw off the fixing screws to remove the rear cover board	
		2) Remove the volute shell	
		3) Remove the fan motor wire from the electronic control box	Refer the operation of step2 of No.1
		4) Disassemble the fan motor fixing clamps to remove the fan motor assembly and fan wheel assembly	
		5) Disassemble the fan wheels, then you can remove the fan motor	
6	Remove the water collector assembly	4) Remove the rear cover board	Repeat the operation of step1 of No.5
		5) Screw off the seven screws to remove the top cover, then remove the water collector assembly	

			 <p>Water collector assembly</p>
7	Remove the evaporator	1) Remove the water collector	Repeat the operation of No.6
		2) Remove the evaporator sensor	 <p>Evaporator sensor</p>
		3) Remove the pipe clamp board	 <p>2 screws</p>
		4) Remove the evaporator support board	 <p>4 screws</p>
		5) Screw off the fixing screws to remove the evaporator	 <p>1 screw</p>

** means there is no this part in some models.