

Exploded View

Customer model:

CPE12CA(O)

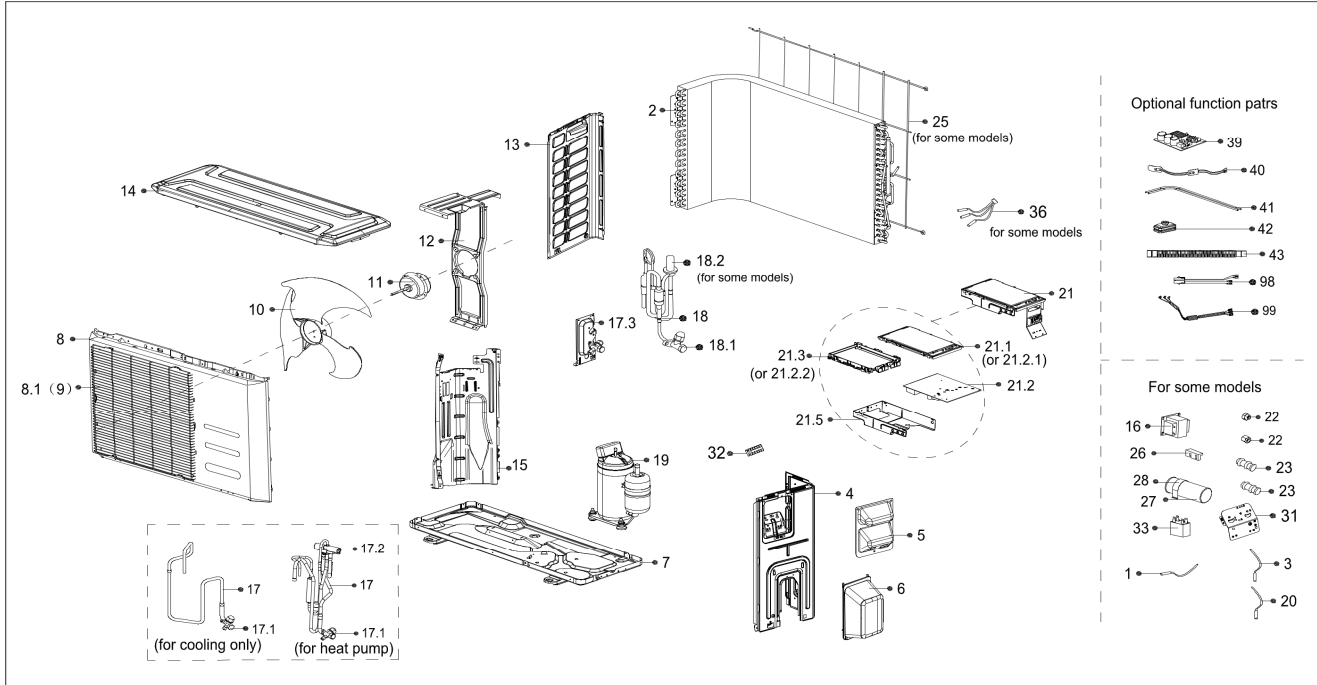

EX_ID	Spare Parts Code	Part Name(EN)	Qty.
1	11201007002321	Room temperature sensor	1
2	15822000A16082	Condenser assembly	1
3	11201007002320	Pipe temperature sensor	1
4	12222000006249	Right clapboard assembly	1
5	12222000010966	Big handle assembly	1
6	12122000007150	Water collector	1
7	12222000004427	Chassis assembly	1
8	12222000004842	Front panel assembly	1
9	12222000007424	Air outlet grille	1
10	12100105000057	Axial flow fan	1
11	11002015008264	Brushless DC Motor	1
12	12222000008924	Supporter subassembly of fan motor	1
13	12222000006244	Left supporter	1
14	12222000006246	Top cover assembly	1
15	12222000004425	Partition board	1
16	17400306000019	Reactor	1
17	15422000004757	Gas valve assembly	1
17.1	15500204000058	Gas valve	1
17.3	12222000002571	Valve plate	1
18	15422000005282	Liquid valve assembly	1
18.1	15500208000028	Liquid valve	1
19	11103020000239	DC Inverter rotary compressor	1
20	11201007000005	Discharge temperature sensor	1
21	17222000009750	Electronic control box subassembly	1
21.2	17122000019192	Outdoor main control board subassembly	1
21.2.1	12222000001455	Cover of electronic control box	1
21.2.2	12122000006913	Support of electronic control box	1
21.5	12222000001311	Electronic installing box subassembly	1
24	15111600A00020	Connecting pipe assembly	1
25	12222000003986	Rear net	1
27	17400103000052	Capacitor of compressor	1
28	12200203000007	Capacitor clip	1
31	12222000002259	Terminal board	1
32	17400401000075	Terminal	1
99	17401203000802	Compressor wire subassembly	1