

Exploded View

Sale Model:

CPR48CD(O)

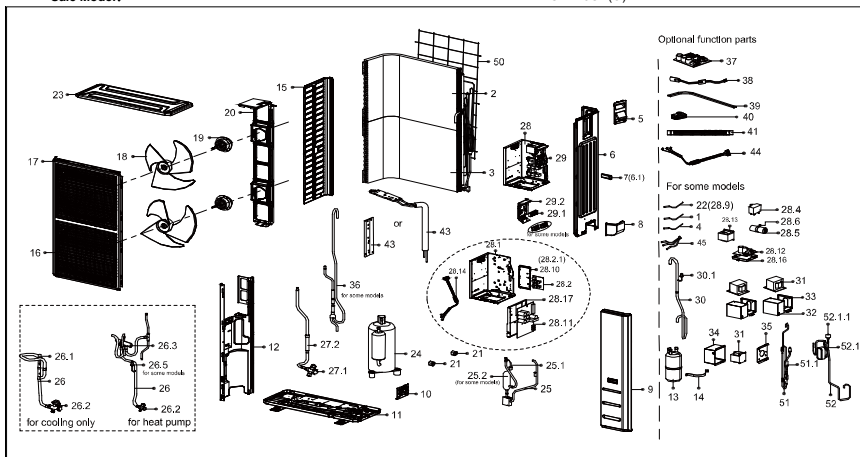

No.	Part Name	Quantity	BOM Code
1	Room Temperature Sensor	1.0	11201007003425
2	Condenser assembly1	1.0	15822200001058
3	Condenser assembly2	1.0	15822200001056
4	Pipe Temperature Sensor for Refrigerant tube	1.0	11201007003445
4	Pipe Temperature Sensor T3(Condenser pipe)	1.0	11201007003439
4	Pipe Temperature Sensor for Suction Pipe	1.0	11201007000136
5	Big handle assembly	1.0	12222000013365
6	Rear right clapboard assembly	1.0	12222000012373
6.1	handle	1.0	12100702000038
8	Water collector	1.0	12122000014023
9	Front right clapboard assembly	1.0	12222000006287
10	Valve plate	1.0	12222000002361
11	Chassis assembly	1.0	12222000006290
12	Partition board assembly	1.0	12222000005733
13	Liquid-storage tank	1.0	15500508000009
15	Left side plate assembly of cabinet	1.0	12222000002363
16	Air outlet grille	2.0	12222000014845
17	Front panel	1.0	12222000007564
18	Axial flow fan	2.0	12100105000022
19	Brushless DC Motor	2.0	11002015009825
20	Supporter subassembly of fan motor	1.0	12222000006288
21	Copper nut for high-pressure valve	1.0	15500406000003
21	Copper nut for low-pressure valve	1.0	15500406000010
22	Discharge Temperature Sensor	1.0	11201007004043
23	Top cover assembly	1.0	12222000002359
24	DC Inverter Rotary Compressor	1.0	11103020002859
25	Discharge pipe assembly	1.0	151220000027660
25.1	high Pressure switch	1.0	17400516000851
26	4-way valve assembly	1.0	15422000020532
26.2	Gas valve	1.0	155002040000061
26.3	4-way valve	1.0	15500216000681
26.5	Pressure sensor	1.0	112010080000773
27	Liquid valve assembly	1.0	15422000020533
27.1	Gas valve	1.0	155002040000021
27.2	Throttle valve	1.0	15500210001888
28	Electronic control box subassembly	1.0	17222000036521
28.1	Installation plate of electric parts subassembly	1.0	12222000012372
28.2	Inverter module subassembly	1.0	17122000053390
28.10	Electronic installing box	1.0	12122000014342
28.11	Outdoor main control board subassembly	1.0	17122000054313
28.14	Compressor wire subassembly	1.0	174012030000936
28.17	Electronic installing box	1.0	12122000020943
29	Terminal board subassembly	1.0	17222000036520
29.1	Wire joint	1.0	17400401003456
29.2	Terminal installation subassembly	1.0	12222000015266
30	Suction pipe assembly	1.0	15122000028742
30.1	low Pressure switch	1.0	17400516000850
38	Crankcase electric heating strip	1.0	17402001000602
39	Electric heating tube	1.0	17402002000466
43	Radiator subassembly	1.0	15122000024994
50	Rear net	1.0	12222000007944
51	Electronic expansion valve subassembly	1.0	15422000020454
51.1	Electronic expansion valve	1.0	15500213000245