



# Submittal

## Split System Cooling

LUC5-36-15

Location: \_\_\_\_\_  
Engineer: \_\_\_\_\_  
Submitted to: \_\_\_\_\_  
Submitted by: \_\_\_\_\_  
Reference: \_\_\_\_\_

Approval: \_\_\_\_\_  
Date: \_\_\_\_\_  
Construction: \_\_\_\_\_  
Unit # : \_\_\_\_\_  
Drawing # : \_\_\_\_\_



Note: " Graphics in this document are for representation only. Actual model may differ in appearance."

## Indoor unit dimension

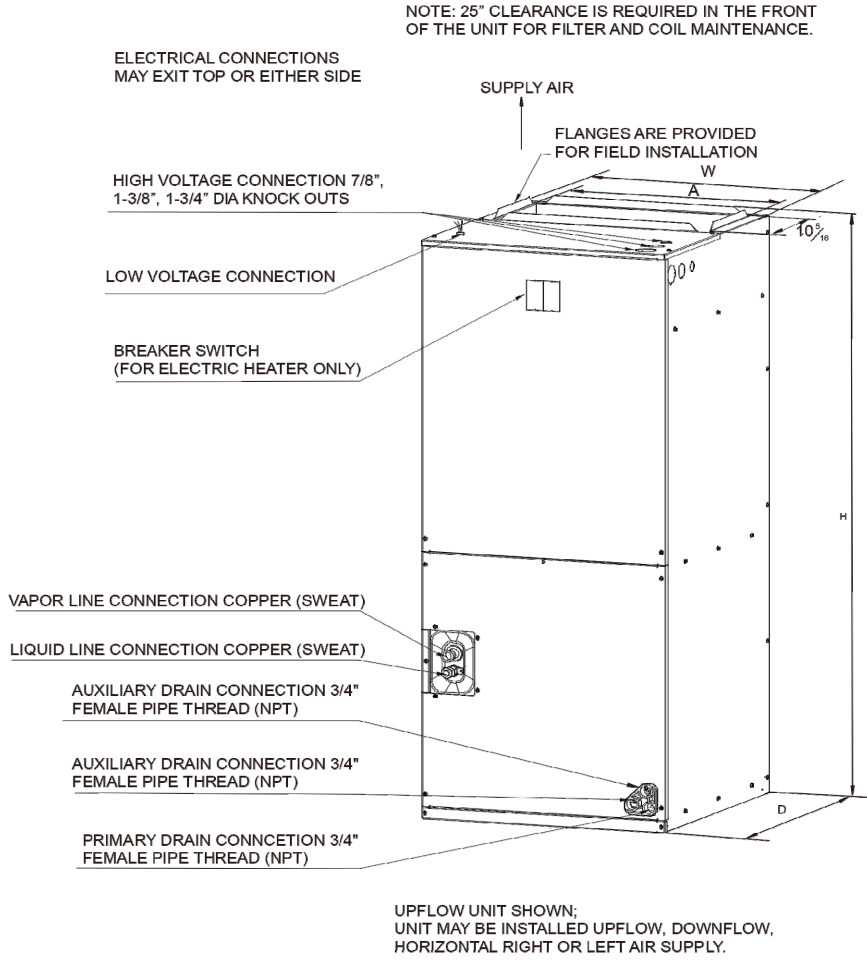

UNIT DIMENSION AND WEIGHTS	18K	24K	36K	48K	60K
Height(in.)	41-3/8	46-1/2	46-1/2	54-1/2	54-1/2
Width(in.)	18-1/8	19-5/8	19-5/8	22	22
Depth(in.)	20-1/2	21-5/8	21-5/8	24	24
Weight(lbs.)	108	128	128	159	161



## Specification

	LUC5-36-15
<b>NOMINAL RATING</b>	
External Static Pressure(in.w.c)	1
<b>ELECTRICAL DATA</b>	
Voltage / Phase(60Hz)	208/230/1
Min. / Max. Voltage	187/253
Min. Circuit Amps	3
Max. Overcurrent Protection	15
<b>FAN MOTOR</b>	
Motor Type	PSC
Capacitor (uF)	10
Horsepower (HP)	1/2
Rated RPM	865
Full Load Amps (FLA)	3
<b>FAN BLOWER</b>	
Material	Metal
Type	Centrifugal
Diameter(in.)	13
Height(in.)	10-5/8
<b>EVAPORATOR COIL</b>	
Type	Tube & Fin
Tube Material	Aluminum
Tube Size(in.)	9/32
<b>REFRIGERANT CONNECTION SIZE</b>	
Liquid Line Size (O.D.)	3/8
Suction Line Size (O.D.)	3/4

Outdoor Unit	Indoor Unit	Cooling Capacity	EER2	SEER2
BAR5-24-15	LUC5-36-15+TXV	23800	11.7	<b>14.3</b>
BAR5-30-15	LUC5-36-15	28600	11.7	<b>14.3</b>
BAR5-36-15	LUC5-36-15	34000	11.7	<b>14.3</b>
MAH5-24-410	LUC5-36-15	23600	11.2	<b>13.4</b>
MAH5-30-410	LUC5-36-15	28000	11.2	<b>13.4</b>
MAH5-36-410	LUC5-36-15	34200	11.2	<b>13.4</b>
MAH5-42-410	LUC5-36-15	39500	11.2	<b>13.4</b>

## Electric Heater Kits

NO.	Kit#	Description	Ref. Air Handler use
1	05	5kW Heat Strip	18,24,30,36,42,48,60
2	08	7.5kW Heat Strip	18,24,30,36,42,48,60
3	10	10kW Heat Strip	18,24,30,36,42,48,60
4	05B	Circuit Breaker, 5kW Heat Strip	18,24,30,36,42,48,60
5	08B	Circuit Breaker, 7.5kW Heat Strip	18,24,30,36,42,48,60
6	10B	Circuit Breaker, 10kW Heat Strip	18,24,30,36,42,48,60
7	15B	Circuit Breaker, 15kW Heat Strip	36,42,48,60
8	20B	Circuit Breaker, 20kW Heat Strip	36,42,48,60

## MCA/MOP DATA

Heat Kit Model	Air Handler Model	(kW)Electric Heat	MIN. Circuit Ampacity		MAX.Fuse or Breaker (HACR) Ampacity	
			240	208	240	208
05(B)	18	5	21	18	30	30
08(B)		7.5	32	28	50	50
10(B)		10	42	36	60	60
05(B)	24	5	21	18	30	30
08(B)		7.5	32	28	50	50
10(B)		10	42	36	60	60
05(B)	30	5	21	18	30	30
08(B)		7.5	32	28	50	50
10(B)		10	42	36	60	60
05(B)	36	5	21	18	30	30
08(B)		7.5	32	28	50	50
10(B)		10	42	36	60	60
15B		15	64	56	30+60	30+60
20B		20	84	72	60+60	60+60
05(B)	42	5	21	18	30	30
08(B)		7.5	32	28	50	50
10(B)		10	42	36	60	60
15B		15	64	56	30+60	30+60
20B		20	84	72	60+60	60+60
05(B)	48	5	21	18	30	30
08(B)		7.5	32	28	50	50
10(B)		10	42	36	60	60
15B		15	64	56	30+60	30+60
20B		20	84	72	60+60	60+60
05(B)	60	5	21	18	30	30
08(B)		7.5	32	28	50	50
10(B)		10	42	36	60	60
15B		15	64	56	30+60	30+60
20B		20	84	72	60+60	60+60

# ComfortStar®

12201 N W 107th Avenue  
Miami, FL 33178  
1.866.524.9898 Toll Free  
305.500.9898 Office  
305.500.9896 Fax  
<http://www.comfortstarusa.com>

---



The AHRI mark indicates Comfortstar participating in the AHRI Certification program. Visit [ahridirectory.org](http://ahridirectory.org) for verification of individual certified products. Comfortstar reserves the right to change design and specs without notice. Comfortstar has a policy of update the data continuously. We are committed to using environmentally conscious print practices.

LUC5-36-15 10 Nov 2022  
Supersedes LUC5-36-15 (Nov.2021)

© 2022 ComfortStar