



Submittal

Split System Cooling

AHU30-SG2

Location: _____
Engineer: _____
Submitted to: _____
Submitted by: _____
Reference: _____

Approval: _____
Date: _____
Construction: _____
Unit # : _____
Drawing # : _____



Note:" *Graphics in this document are for representation only. Actual model may differ in appearance.*"

ComfortStar®

Indoor unit installation size

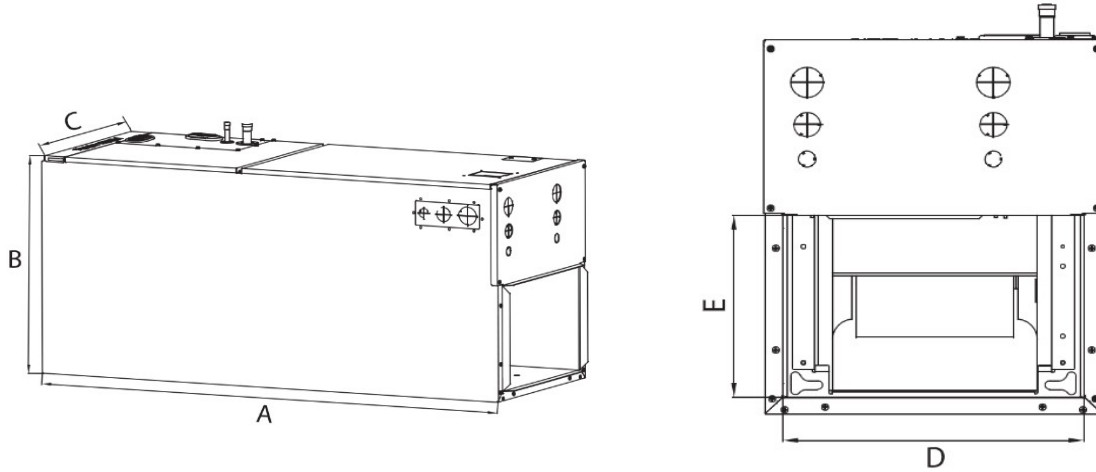

(unit:mm/inch)

Dimensions		Model		
		12K ~ 24K	30K ~ 48K	60K
Length of A	mm	1143	1245	1346
	inch	45	49	53
Length of B	mm	533	533	533
	inch	21	21	21
Length of C	mm	445	533	622
	inch	17-1/2	21	24-1/2
Length of D	mm	400	490	580
	inch	15-3/4	19-5/16	22-27/32
Length of E	mm	260	260	260
	inch	10-1/4	10-1/4	10-1/4

Recommended size of filter

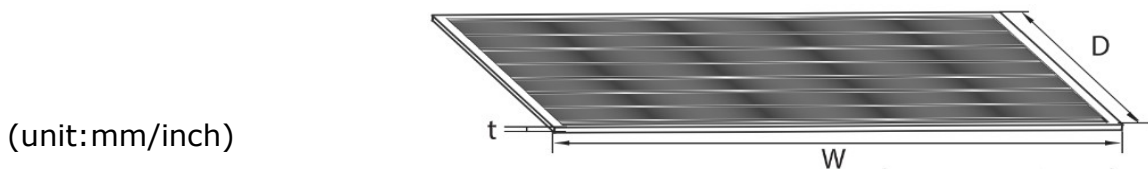

(unit:mm/inch)

Recommended size of filter		Model (Btu/h)		
		12K ~24K	30K~36K	48K ~60K
W	mm	406.4	495.3	584.2
	inch	16	19-1/2	23
D	mm	508	508	508
	inch	20	20	20
t	mm	25.4	25.4	25.4
	inch	1	1	1

SYSTEM PERFORMANCE DATA		
Power supply		
Normal Operational Voltage	(V, Ph, Hz)	208/230, 1, 60
Voltage Range	(V)	187-253
Electrical		
Minimum circuit ampacity	(A)	20
Max.fuse	(A)	35
Connection wiring		16AWG*2 Stranded, shielded
Cooling		
Rated Capacity	(Btu/h)	30000
Capacity Range	(Btu/h)	9482~33000
Power Input	(W)	2760
Rated current	(A)	12.20
SEER2	(Btu/W)	17.3
EER2	(Btu/W)	10.6
Heating at 47F		
Rated Capacity	(Btu/h)	31000
Capacity Range	(Btu/h)	12200~32000
Power Input	(W)	2850
Rated current	(A)	12.40
HSPF2-4	(Btu/W)	8.5
HSPF2-5	(Btu/W)	6.6
COP	W/W	3.19
Throttle type	Indoor unit	EEV for cooling
Indoor(cooling/ heating)	(Deg. °F)	60~90/32~86
	(Deg. °C)	16~32/0~30
Application area	(sq.ft)	430.56~635.07
	(m2)	40~59
INDOOR UNIT DATA		
Indoor fan motor		
Type		Centrifugal
Model		ZKFD-375-8-1
Qty		1
Input	(W)	168
RLA	(A)	---
LRA	(A)	---
Winding Resistance	(Ω)	---
Capacitor	(uF)	---
Speed(Hi/Mi/Lo)	(r/min)	---
Air flow & Noise level		
Indoor air flow (Hi/Med/Lo) (No duct)	(CFM)	894.12/805.88/711.76
Indoor noise level (Hi/Med/Lo)	[dB(A)]	43/40/30.5
Dehumidification	(Pint/H)	---
Indoor unit		
Dimension (WxDxH)	(inch)	21.02x21.02x49.02
	(mm)	534x534x1245
Packing(WxDxH)	(inch)	25.20x24.41x54.33
	(mm)	640x620x1380
Net/Gross weight	(lbs.)	58.6/70.6
	(kg)	129.19/155.64

Fan performance

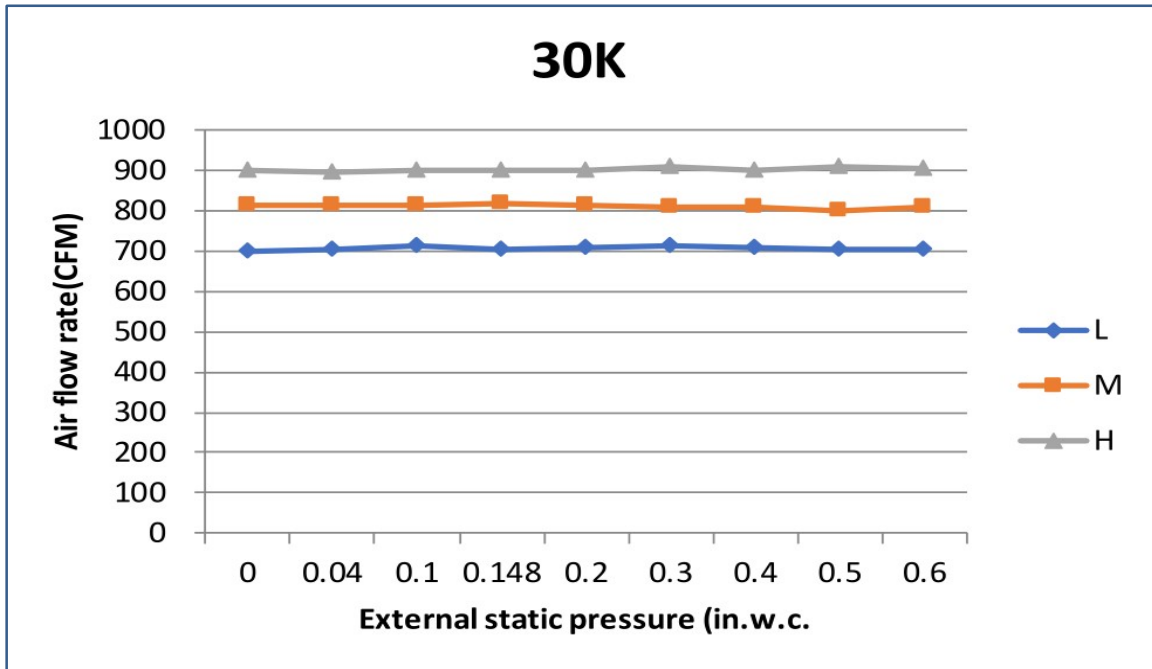

ComfortStar®

12201 N W 107th Avenue
Miami, FL 33178
1.866.524.9898 Toll Free
305.500.9898 Office
305.500.9896 Fax
<http://www.comfortstarusa.com>



The AHRI mark indicates Comfortstar participating in the AHRI Certification program. Visit ahridirectory.org for verification of individual certified products. Comfortstar reserves the right to change design and specs without notice. Comfortstar has a policy of update the data continuously. We are committed to using environmentally conscious print practices.

AHU30-SG2 22 Jun 2022
Supersedes AHU30-SG2 (Sept.2021)

© 2022 ComfortStar