

SUBMITTAL DATA SHEET



CGS36CD(I)/CGS36CD(O)	36,000 BTU/H(208/230V) Wall Mounted Heat Pump System
Location: _____	Approval: _____
Engineer: _____	Date: _____
Submitted to: _____	Construction: _____
Submitted by: _____	Unit #: _____
Reference: _____	Drawing #: _____

Set Model
 Indoor unit model CGS36CD(I)
 Outdoor unit model CGS36CD(O)

Certified

AHRI 

UL 



SYSTEM PERFORMANCE DATA		
Power supply		
Normal Operational Voltage (V, Ph, Hz)		208/230, 1, 60
Voltage Range (V)		187-253
Electrical		
Minimum circuit ampacity (A)		28.0
Max.fuse (A)		35.0
Connection wiring		14*4 AWG
Cooling		
Rated Capacity (Btu/h)		36000
Capacity Range (Btu/h)		8300~37500
Power Input (Max) (W)		3790
Rated current (A)		16.8
SEER2 (Btu/W)		18.0
EER2 (Btu/W)		9.5
Heating at 47F		
Rated Capacity (Btu/h)		36000
Capacity Range (Btu/h)		10900~37360
Power Input (Max) (W)		3790
Rated current (A)		16.8
HSPF2-4 (Btu/W)		7.8
HSPF2-5 (Btu/W)		6.0
COP W/W		2.78
Heating at 17F		
Max Capacity (Btu/h)		25000
REFRIGERANT PIPE DATA		
Design pressure (PSIG)		550/340
Refrigerant Type (Oz)		R410A/119.9
Refrigerant precharge (ft)		25.0
	(m)	7.6
Additional charge for each ft (oz/ft)		0.32
	(g/ft)	30
Liquid side/ Gas side (inch)		3/8" / 5/8"
	(mm)	Φ9.52 / Φ15.9
Max. pipe length (ft)		213.0
	(m)	65.0
Max. difference in level (ft)		98.0
	(m)	30.0
Connection method		(Flared)
Indoor(cooling/ heating) (Deg. °F)		60~90 / 32~86
	(Deg. °C)	16~32 / 0~30
Outdoor(cooling/heating) (Deg. °F)		5~122 / 5~75
	(Deg. °C)	-15~-50 / -15~-24
Application area (sq.ft)		516.67~753.47
	(m2)	48~70

INDOOR UNIT DATA		
Indoor fan motor		
Type		Cross-Flow
Model		ZKFP-58-8-1-5
Qty		1
Input (W)		58.0
RLA (A)		--
LRA (A)		--
Winding Resistance (Ω)		--
Capacitor (uF)		--
Speed(Hi/Mi/Lo) (r/min)		1200/960/600
Air flow & Noise level		
Indoor air flow (Hi/Med/Lo) (No duct) (CFM)		652.94/447.06/329.41
Indoor noise level (Hi/Med/Lo) [dB(A)]		54/45/40
Dehumidification (Pint/H)		--
Indoor unit		
Dimension (WxDxH) (inch)		49.57x11.14x14.25
	(mm)	1259x283x362
Packing(WxDxH) (inch)		52.76x17.72x15.16
	(mm)	1340x450x385
Net/Gross weight (lbs.)		42.77/55.56
	(kg)	19.4/25.2
OUTDOOR UNIT DATA		
Compressor		
Type		KTF250D22UMT
Model		ROTARY
Brand		GMCC
Capacity (Btu/h)		27621.286
Input (W)		2200
Rated current (RLA) (A)		--
Refrigerant oil/oil charge (ml)		--
Throttle		Capillary +EXV
Outdoor fan motor		
Model		ZKFN-120-8-2
Qty		1
Input (W)		--
RLA (A)		--
Speed (r/min)		1150/1050/900/850
Air flow & Noise level		
Outdoor air flow (Max.) (CFM)		2235.30
Outdoor noise level [dB(A)]		61.5
Outdoor unit		
Dimension (W×D×H) (inch)		37.24x16.14x31.89
	(mm)	946x410x810
Packing (W×D×H) (inch)		42.91x19.69x34.84
	(mm)	1090x500x885
Net/ Gross weight (lbs.)		150.13/158.95
	(kg)	68.1/72.1

Indoor unit dimension

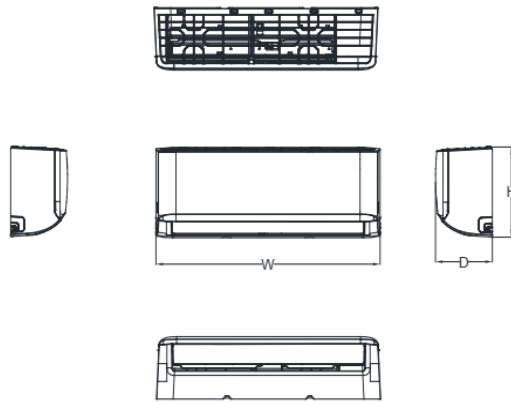

Capacity	Body Code	W(mm/inch)	D(mm/inch)	H(mm/inch)
6K~11K	A	729/28.7	200/7.87	292/11.5
8K~14K	B	802/31.57	200/7.87	295/11.61
12K~21K	C	971/38.23	228/8.98	321/12.64
18K~28K	D	1082/42.6	234/9.21	337/13.27
27K~36K	F	1259/49.57	283/11.14	362/14.25

Outdoor unit dimension

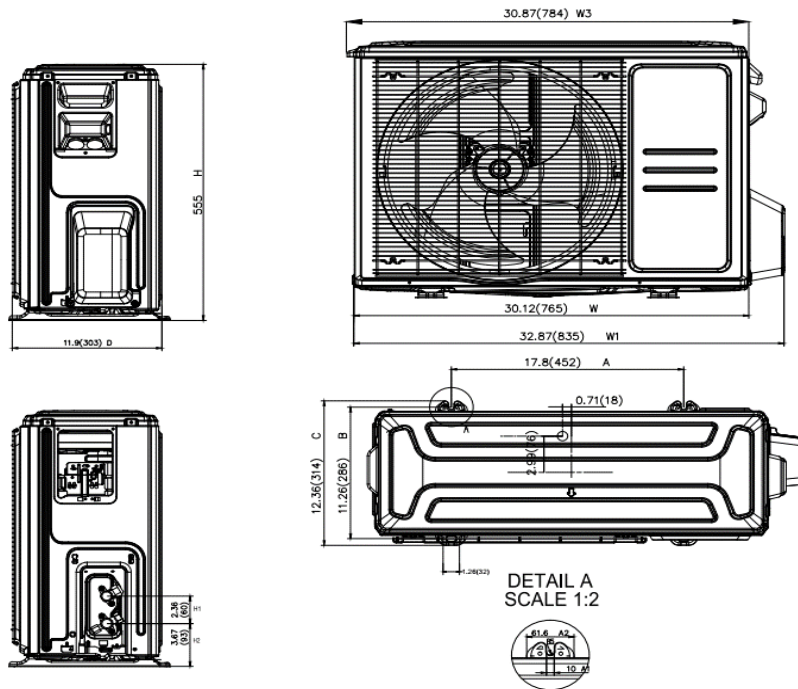

General Features

Wireless Remote with LCD Display
46F Heating
Sleep Mode
Silent Mode
Self Clean
Follow Me (optional)

Extended Performance Data