

SUBMITTAL DATA SHEET

ComfortStar®

| CHF18CD(I)/CZP18CD(O) | Wall Mounted Heat Pump System |
|-----------------------|-------------------------------|
| Location: _____ | Approval: _____ |
| Engineer: _____ | Date: _____ |
| Submitted to: _____ | Construction: _____ |
| Submitted by: _____ | Unit #: _____ |
| Reference: _____ | Drawing #: _____ |

Set Model
 Indoor unit model CHF18CD(I)
 Outdoor unit model CZP18CD(O)

Certified

AHRI 

UL 



| SYSTEM PERFORMANCE DATA | | |
|--|-----------|------------------|
| Power supply | | |
| Normal Operational Voltage (V, Ph, Hz) | | 208/230,1,60 |
| Voltage Range (V) | | 187-253 |
| Electrical | | |
| Minimum circuit ampacity (A) | | 17.0 |
| Max.fuse (A) | | 25.0 |
| Connection wiring | | 16*4 AWG |
| Cooling | | |
| Rated Capacity (Btu/h) | | 18000 |
| Capacity Range (Btu/h) | | 2000~19300 |
| Power Input (Max) (W) | | 1440 |
| Rated current (A) | | 6.45 |
| SEER2 (Btu/W) | | 23.5 |
| EER2 (Btu/W) | | 12.5 |
| Heating at 47F | | |
| Rated Capacity (Btu/h) | | 19000 |
| Capacity Range (Btu/h) | | 6200~21000 |
| Power Input (Max) (W) | | 1650 |
| Rated current (A) | | 7.4 |
| HSPF2-4 (Btu/W) | | 9.4 |
| HSPF2-5 (Btu/W) | | 7.0 |
| COP W/W | | 3.37 |
| Heating at 17F | | |
| Max Capacity (Btu/h) | | 15600 |
| REFRIGERANT PIPE DATA | | |
| Design pressure (PSIG) | | 550/340 |
| Refrigerant Type (Oz) | | R410A/56.44 |
| Refrigerant precharge (ft) | | 25.0 |
| | (m) | 7.6 |
| Additional charge for each ft (oz/ft) | | 0.16 |
| | (g/ft) | 15 |
| Liquid side/ Gas side (inch) | | 1/4" / 1/2" |
| | (mm) | 6.35/12.7 |
| Max. pipe length (ft) | | 98.0 |
| | (m) | 30.0 |
| Max. difference in level (ft) | | 66.0 |
| | (m) | 20.0 |
| Connection method | | (Flared) |
| Indoor(cooling/ heating) (Deg. °F) | | 60~90 / 32~86 |
| | (Deg. °C) | 16~32 / 0~30 |
| Outdoor(cooling/heating) (Deg. °F) | | -13~122 / -13~75 |
| | (Deg. °C) | -25~50 / -25~24 |
| Application area (sq.ft) | | 258.33~376.74 |
| | (m2) | 24~35 |

| INDOOR UNIT DATA | | |
|---|------|----------------------|
| Indoor fan motor | | |
| Type | | Cross-Flow |
| Model | | ZKFP-30-8-3-10 |
| Qty | | 1 |
| Input (W) | | 36.0 |
| RLA (A) | | 0.4 |
| LRA (A) | | -- |
| Winding Resistance (Ω) | | -- |
| Capacitor (uF) | | -- |
| Speed(Hi/Mi/Lo) (r/min) | | 1240/1024/916 |
| Air flow & Noise level | | |
| Indoor air flow (Hi/Med/Lo) (No duct) (CFM) | | 523.53/376.47/305.88 |
| Indoor noise level (Hi/Med/Lo) [dB(A)] | | 46.5/43/32.5 |
| Dehumidification (Pint/H) | | |
| | | -- |
| Indoor unit | | |
| Dimension (WxDxH) (inch) | | 37.99x9.41x12.56 |
| | (mm) | 965x239x319 |
| Packing(WxDxH) (inch) | | 41.14x15.75x12.80 |
| | (mm) | 1045x400x325 |
| Net/Gross weight (lbs.) | | 27.12/35.71 |
| | (kg) | 12.3/16.2 |
| OUTDOOR UNIT DATA | | |
| Compressor | | |
| Type | | KSN140D58UFZ |
| Model | | ROTARY |
| Brand | | GMCC |
| Capacity (Btu/h) | | 14723 |
| Input (W) | | 1090 |
| Rated current (RLA) (A) | | -- |
| Refrigerant oil/oil charge (ml) | | -- |
| Throttle | | Capillary +EXV |
| Outdoor fan motor | | |
| Model | | ZKFN-80-8-3 |
| Qty | | 1 |
| Input (W) | | -- |
| RLA (A) | | -- |
| Speed (r/min) | | 810/720 |
| Air flow & Noise level | | |
| Outdoor air flow (Max.) (CFM) | | 1764.70 |
| Outdoor noise level [dB(A)] | | 58 |
| Outdoor unit | | |
| Dimension (W×D×H) (inch) | | 35.04x13.46x26.50 |
| | (mm) | 890x342x673 |
| Packing (W×D×H) (inch) | | 39.17x15.67x29.13 |
| | (mm) | 995x398x740 |
| Net/ Gross weight (lbs.) | | 95.02/101.85 |
| | (kg) | 43.1/46.2 |

Indoor unit dimension

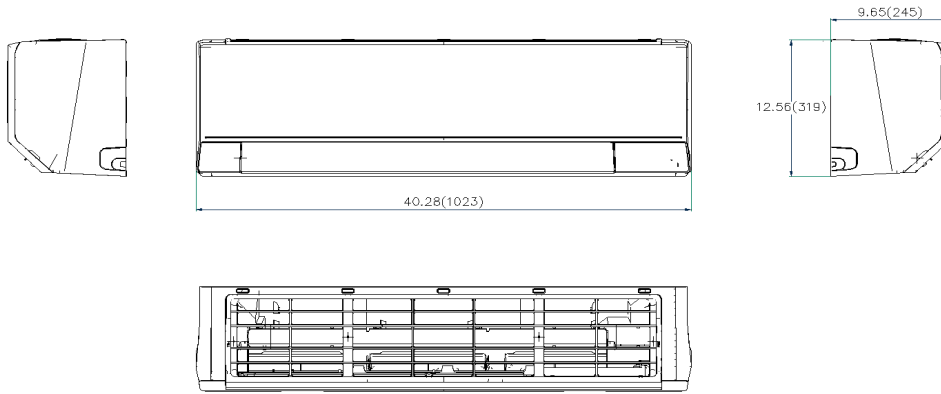

Outdoor unit dimension

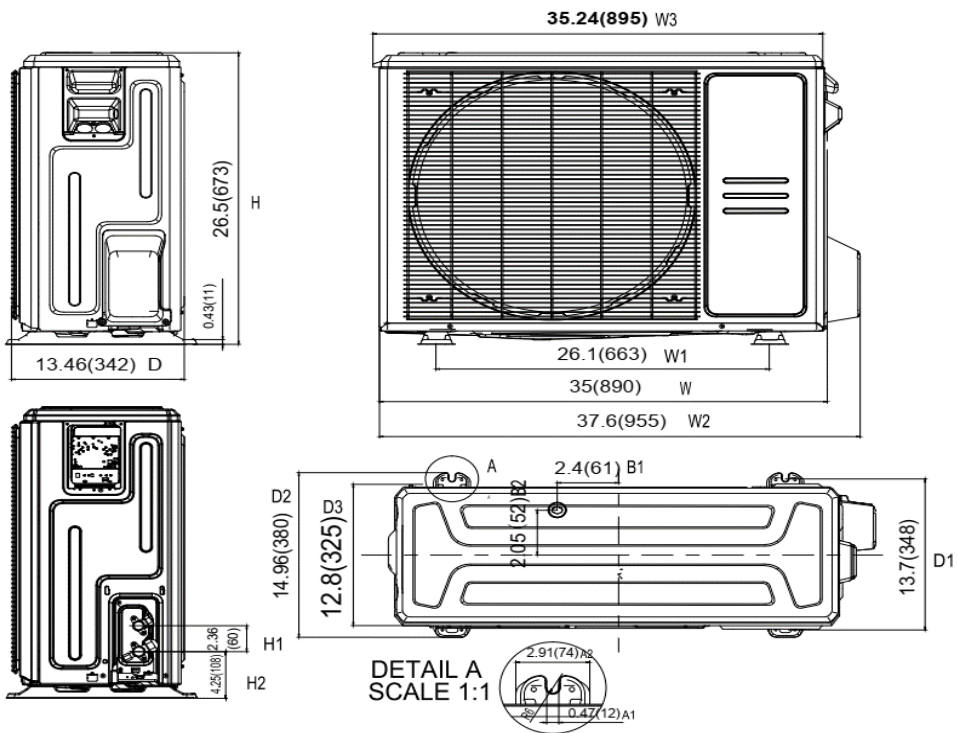

General Features

Intelligent Eye(optional)

Easy Installation

Easy Maintenance

Easy Clean

High Efficiency

Wireless Remote with LCD Display

Extended Performance Data