

SUBMITTAL DATA SHEET



<b>CMZ-27-3Z</b>	
Location: _____ Engineer: _____ Submitted to: _____ Submitted by: _____ Reference: _____	Approval: _____ Date: _____ Construction: _____ Unit #: _____ Drawing #: _____

Outdoor unit model **CMZ-27-3Z**

**Certified** **UL**



**SYSTEM PERFORMANCE DATA**

<b>Power supply</b>		
Normal Operational Voltage	(V, Ph, Hz)	208/230, 1, 60
Voltage Range	(V)	187-253
<b>Cooling</b>		
Capacity	Btu/h	28000(9838~30438)
Input	W	2240
Rated current	A	11
<b>Heating</b>		
Capacity	Btu/h	28000(8218~31000)
Input	W	2200
Rated current	A	10.5

**REFRIGERANT PIPE DATA**

Design pressure	(PSIG)	550/340
Refrigerant Type	(Oz)	R410A/91.7
Refrigerant precharge	(ft)	74
	(m)	22.5
Additional charge for each ft-Φ6.35 (1/4")	(oz/ft)	0.161
Additional charge for each ft-Φ9.52 (3/8") liquid pipe	(oz/ft)	0.322
Liquid side/ Gas side	(inch)	3 x 1/4"/3 x 3/8"
	(mm)	3 x Φ6.35/3 x Φ9.52
Max. length for all rooms	(ft)	197
Max. length for one indoor	(ft)	98.0
Max. height difference between indoor and outdoor unit	(ft)	49
Max. height difference between indoor units	(ft)	33

**OUTDOOR UNIT DATA**

<b>Compressor</b>		
Model		KTM240D43UKT
Type		ROTARY
Brand		GMCC
Capacity	(Btu/h)	24293.44
Input	(W)	1895
Rated current (RLA)	(A)	-
Refrigerant oil/oil charge	(ml)	VG74/620
Throttle		Capillary +EXV
<b>Air flow &amp; Noise level</b>		
Outdoor air flow (Max.)	(CFM)	2129.41
Outdoor noise level	[dB(A)]	61
<b>Outdoor unit</b>		
Dimension (W×D×H)	(inch)	37.24x16.14x31.89
	(mm)	946x410x810
Packing (W×D×H)	(inch)	42.91x19.69x34.84
	(mm)	1090x500x885
Net/ Gross weight	(lbs.)	139.77/150.57
	(kg)	63.4/68.3
<b>Outdoor (cooling/heating)</b>	(Deg. °F)	-13~122/ -13~86
	(Deg. °C)	-25~50/ -25~30

EER2 (Non-ducted)	12.7	EER2 (Ducted)	11.5	MIX EER2	12.10
SEER2 (Non-ducted)	24.6	SEER2 (Ducted)	21	MIX SEER2	22.80
HSPF2-4(Non-ducted)	9.3	HSPF2-4(Ducted)	9.2	MIX HSPF2-4	9.25
HSPF2-5(Non-ducted)	7.1	HSPF2-5(Ducted)	7	MIX HSPF2-5	7.05

**Outdoor unit dimension**

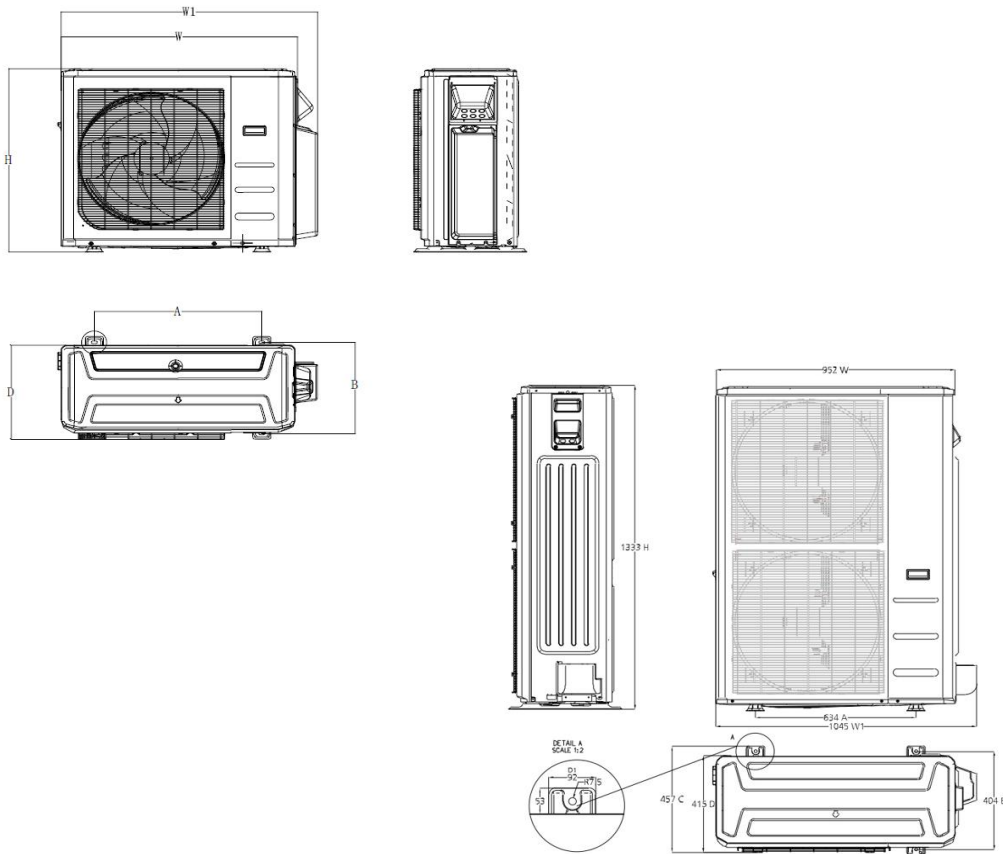

Model	Unit	W	D	H	W1	A	B	C	D
CMZ-18-2Z	mm	890	342	673	990	663	354	/	/
	inch	35.04	13.46	26.5	38.98	26.1	13.94	/	/
CVH-18-2SH	mm	946	410	810	1034	673	403	/	/
CMZ-27-3Z									
CVH-27-3SH	inch	37.24	16.14	31.89	40.6	26.5	15.9	/	/
CMZ-48-4Z									
CVH-36-4SH	mm	952	415	1333	1045	634	404	457	415
CMZ-54-5Z									
CMZ-60-5Z	inch	37.48	16.34	52.48	411.4	249.6	159.1	179.9	163.4
CVH-60-5SH									

**24V INTERFACE KIT**

