

SUBMITTAL DATA SHEET





**CPA-36DUB/CZP36CD(O) 36,000 BTU/H(208/230V) Wall Mounted Heat Pump System**

Location: _____ Engineer: _____ Submitted to: _____ Submitted by: _____ Reference: _____	Approval: _____ Date: _____ Construction: _____ Unit #: _____ Drawing #: _____
--	--

**Set Model**  
 Indoor unit model CPA-36DUB  
 Outdoor unit model CZP36CD(O)

**Certified**

AHRI 

CSA 

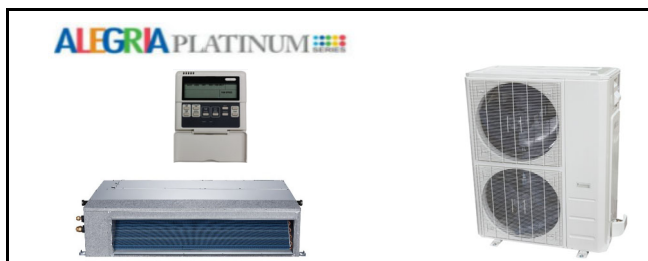

**SYSTEM PERFORMANCE DATA**

<b>Power supply</b>		
Normal Operational Voltage (V, Ph, Hz)		208/230, 1, 60
Voltage Range (V)		187-253
<b>Electrical</b>		
Minimum circuit ampacity (A)		30.0
Max.fuse (A)		45.0
Connection wiring		14AWG*2 Stranded, shielded
<b>Cooling</b>		
Rated Capacity (Btu/h)		36000
Capacity Range (Btu/h)		5973~36000
Power Input (Max) (W)		4000
Rated current (A)		18.3
SEER2 (Btu/W)		15.8
EER2 (Btu/W)		8.8
<b>Heating at 47F</b>		
Rated Capacity (Btu/h)		40000
Capacity Range (Btu/h)		12765~40000
Power Input (Max) (W)		3478
Rated current (A)		15.9
HSPF2-4 (Btu/W)		8.8
HSPF2-5 (Btu/W)		7.0
COP2 (W/W)		3.37
<b>Heating at 17F</b>		
Max Capacity (Btu/h)		25000

**REFRIGERANT PIPE DATA**

Design pressure (PSIG)		550/340
Refrigerant Type (Oz)		R410A/112.9
Refrigerant precharge (ft)		25.0
	(m)	7.6
Additional charge for each ft (oz/ft)		0.32
	(g/ft)	30
Liquid side/ Gas side (inch)		3/8" / 5/8"
	(mm)	9.52/15.9
Max. pipe length (ft)		213.0
	(m)	65.0
Max. difference in level (ft)		98.0
	(m)	30.0
Connection method		(Flared)
Indoor(cooling/ heating) (Deg. °F)	32~86 / 516.67~753.47	
	(Deg. °C)	0~30 / 48~70
Outdoor(cooling/heating) (Deg. °F)	5~122 / 5~75	
	(Deg. °C)	-15~50 / -15~30
Application area (sq.ft)	516.67~753.47	
	(m2)	48~70

**INDOOR UNIT DATA**

<b>Indoor fan motor</b>		
Type		Cross-Flow
Model		ZKFN-300-8-1
Qty		1
Input (W)		250.0
RLA (A)		--
LRA (A)		--
Winding Resistance (Ω)		--
Capacitor (uF)		--
Speed(Hi/Mi/Lo) (r/min)		1130/1050/990
<b>Air flow &amp; Noise level</b>		
Indoor air flow (Hi/Med/Lo) (No duct) (CFM)		1081.76/912.35/702.94
Indoor noise level (Hi/Med/Lo) [dB(A)]		48.0/43.5/40.5
<b>Dehumidification</b> (Pint/H)		--
<b>Indoor unit</b>		
Dimension (WxDxH) (inch)		54x30x10
	(mm)	1360x774x249
Packing(WxDxH) (inch)		62x32x12
	(mm)	1570x805x305
Net/Gross weight (lbs.)		106/122
	(kg)	48.3/55.5

**OUTDOOR UNIT DATA**

<b>Compressor</b>		
Type		KTF310D43UMT
Model		ROTARY
Brand		GMCC
Capacity (Btu/h)		32380
Input (W)		2600
Rated current (RLA) (A)		-
Refrigerant oil/oil charge (ml)		INT01L-4639
Throttle		Capillary +EXV
<b>Outdoor fan motor</b>		
Model		ZKFN-120-8-2
Qty		1
Input (W)		--
RLA (A)		--
Speed (r/min)		1050/900/850
<b>Air flow &amp; Noise level</b>		
Outdoor air flow (Max.) (CFM)		2117.70
Outdoor noise level [dB(A)]		65
<b>Outdoor unit</b>		
Dimension (W×D×H) (inch)		37.24x16.14x31.89
	(mm)	946x410x810
Packing (W×D×H) (inch)		42.91x19.69x34.84
	(mm)	1090x500x885
Net/ Gross weight (lbs.)		155.42/166.23
	(kg)	70.5/75.4

Indoor unit dimension

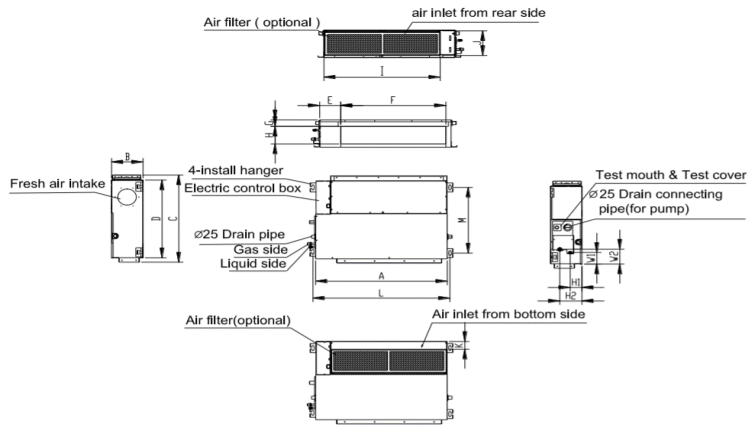

Model (Kbtu/h)	unit	A	B	C	D	E	F	G	H	I	J	K	L	M	H1	H2	W1	W2
9/12	mm	700	200	506	450	137	537	30	152	599	186	50	741	360	84	140	84	84
	inch	27.6	7.9	19.9	17.7	5.4	21.1	1.2	6.0	23.6	7.3	2.0	29.2	14.2	3.3	5.5	3.3	3.3
18	mm	880	210	674	600	140	706	50	136	782	190	40	920	508	78	148	88	112
	inch	34.6	8.3	26.5	23.6	5.5	27.8	2.0	5.4	30.8	7.5	1.6	36.2	20.0	3.1	5.8	3.5	4.4
24	mm	1100	249	774	700	140	926	50	175	1001	228	5	1140	598	80	150	130	155
	inch	43.3	9.8	30.5	27.6	5.5	36.5	2.0	6.9	39.4	9.0	0.2	44.9	23.5	3.1	5.9	5.1	6.1
36	mm	1360	249	774	700	140	1186	50	175	1261	228	5	1400	598	80	150	130	155
	inch	53.5	9.8	30.5	27.6	5.5	46.7	2.0	6.9	49.6	9.0	0.2	55.1	23.5	3.1	5.9	5.1	6.1
48	mm	1200	300	874	800	123	1044	50	227	1101	280	5	1240	697	80	150	185	210
	inch	47.2	11.8	34.4	31.5	4.8	41.1	2.0	8.9	43.3	11.0	0.2	48.8	27.4	3.1	5.9	7.3	8.3

Outdoor unit dimension

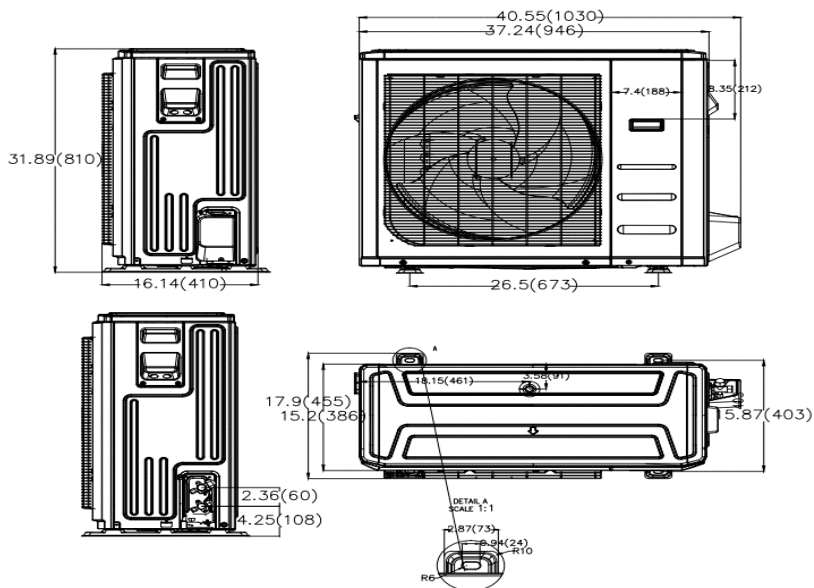

**General Features**

Wired controller  
Weekly-time wired controller(optional)  
Central controller  
Long distance Alarm and ON/OFF controller  
Build-in pump

**Extended Performance Data**