

SUBMITTAL DATA SHEET



CPA-60DU/CZP60CD(O)-B	60,000 BTU/H(208/230V) Wall Mounted Heat Pump System
Location: _____	Approval: _____
Engineer: _____	Date: _____
Submitted to: _____	Construction: _____
Submitted by: _____	Unit #: _____
Reference: _____	Drawing #: _____

Set Model
 Indoor unit model CPA-60DU
 Outdoor unit model CZP60CD(O)-B

Certified

AHRI

CSA



SYSTEM PERFORMANCE DATA

Power supply		
Normal Operational Voltage (V, Ph, Hz)		208/230, 1, 60
Voltage Range (V)		187-253
Electrical		
Minimum circuit ampacity (A)		36.0
Max.fuse (A)		50.0
Connection wiring		14AWG*2 Stranded, shielded
Cooling		
Rated Capacity (Btu/h)		59000
Capacity Range (Btu/h)		11000~57000
Power Input (Max) (W)		5700
Rated current (A)		25.0
SEER2 (Btu/W)		17.0
EER2 (Btu/W)		10.3
Heating at 47F		
Rated Capacity (Btu/h)		60000
Capacity Range (Btu/h)		12000~61000
Power Input (Max) (W)		5048
Rated current (A)		23
HSPF2-4 (Btu/W)		8.4
HSPF2-5 (Btu/W)		6.5
COP2 (W/W)		3.5
Heating at 17F		
Max Capacity (Btu/h)		37600

REFRIGERANT PIPE DATA

Design pressure (PSIG)		550/340
Refrigerant Type (Oz)		R410A/163
Refrigerant precharge (ft)		25.0
	(m)	7.6
Additional charge for each ft (oz/ft)		0.32
	(g/ft)	30
Liquid side/ Gas side (inch)		3/8" / 5/8"
	(mm)	9.52/15.9
Max. pipe length (ft)		213.0
	(m)	65.0
Max. difference in level (ft)		98.0
	(m)	30.0
Connection method		(Flared)
Indoor(cooling/ heating) (Deg. °F)	32~86 / 818.06~1194.79	
	(Deg. °C)	0~30 / 76~111
Outdoor(cooling/heating) (Deg. °F)	5~122 / 5~75	
	(Deg. °C)	-15~50 / -15~30
Application area (sq.ft)	818.06~1194.79	
	(m2)	76~111

INDOOR UNIT DATA

Indoor fan motor		
Type		Cross-Flow
Model		ZKFN-700-8-1
Qty		1
Input (W)		420
RLA (A)		3.65
LRA (A)		--
Winding Resistance (Ω)		--
Capacitor (uF)		--
Speed(Hi/Mi/Lo) (r/min)		1060/910/790
Air flow & Noise level		
Indoor air flow (Hi/Med/Lo) (No duct) (CFM)		2157/1710/1262
Indoor noise level (Hi/Med/Lo) [dB(A)]		50.5/47/43
Dehumidification (Pint/H)		--
Indoor unit		
Dimension (WxDxH) (inch)		55.12/33.78/17.32
	(mm)	1400/858/460
Packing(WxDxH) (inch)		63.19/35.83/19.88
	(mm)	1605/910/535
Net/Gross weight (lbs.)		163.11/189.6
	(kg)	74/86

OUTDOOR UNIT DATA

Compressor		
Type		KTQ420D1UMU
Model		ROTARY
Brand		GMCC
Capacity (Btu/h)		44697
Input (W)		3420
Rated current (RLA) (A)		23.5
Refrigerant oil/oil charge (ml)		INT01L-4639
Throttle		Capillary +EXV
Outdoor fan motor		
Model		ZKFN-85-8-22-5
Qty		2
Input (W)		--
RLA (A)		--
Speed (r/min)		900/850/800/750
Air flow & Noise level		
Outdoor air flow (Max.) (CFM)		4411.76
Outdoor noise level [dB(A)]		65
Outdoor unit		
Dimension (WxDxH) (inch)		37.48x16.34x52.48
	(mm)	952x415x1333
Packing (WxDxH) (inch)		43.11x19.49x58.27
	(mm)	1095x495x1480
Net/ Gross weight (lbs.)		225.09/254.41
	(kg)	102.1/115.4

Indoor unit dimension

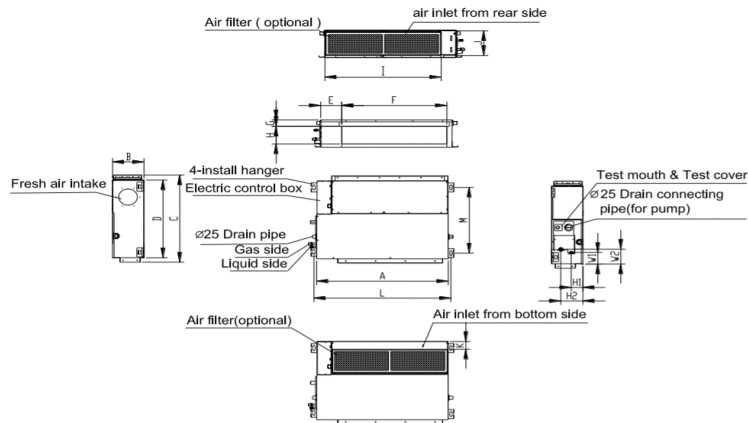

Model (KBTu/h)	unit	A	B	C	D	E	F	G	H	I	J	K	L	M	H1	H2	W1	W2
		9/12	mm	700	200	506	450	137	537	30	152	599	186	50	741	360	84	140
	inch	27.6	7.9	19.9	17.7	5.4	21.1	1.2	6.0	23.6	7.3	2.0	29.2	14.2	3.3	5.5	3.3	3.3
18	mm	880	210	674	600	140	706	50	136	782	190	40	920	508	78	148	88	112
	inch	34.6	8.3	26.5	23.6	5.5	27.8	2.0	5.4	30.8	7.5	1.6	36.2	20.0	3.1	5.8	3.5	4.4
24	mm	1100	249	774	700	140	926	50	175	1001	228	5	1140	598	80	150	130	155
	inch	43.3	9.8	30.5	27.6	5.5	36.5	2.0	6.9	39.4	9.0	0.2	44.9	23.5	3.1	5.9	5.1	6.1
36	mm	1360	249	774	700	140	1186	50	175	1261	228	5	1400	598	80	150	130	155
	inch	53.5	9.8	30.5	27.6	5.5	46.7	2.0	6.9	49.6	9.0	0.2	55.1	23.5	3.1	5.9	5.1	6.1
48	mm	1200	300	874	800	123	1044	50	227	1101	280	5	1240	697	80	150	185	210
	inch	47.2	11.8	34.4	31.5	4.8	41.1	2.0	8.9	43.3	11.0	0.2	48.8	27.4	3.1	5.9	7.3	8.3

Outdoor unit dimension

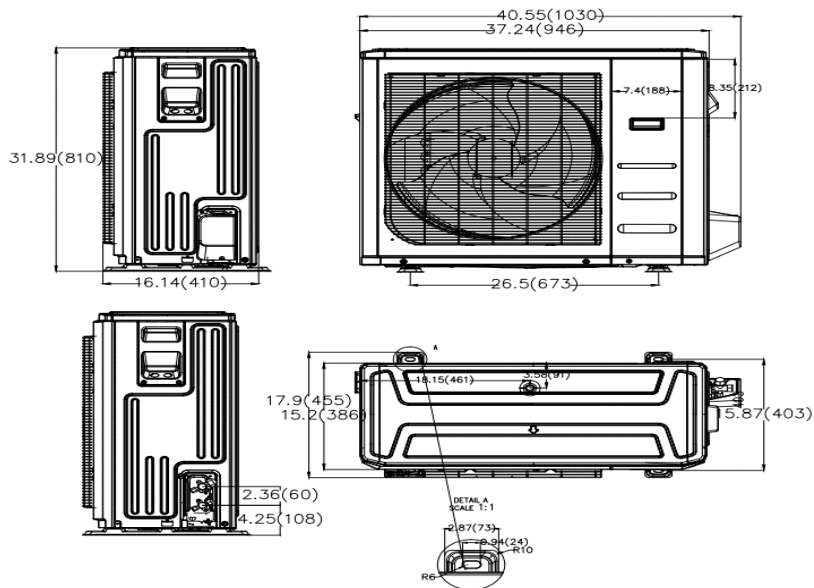

General Features

Wired controller
Weekly-time wired controller(optional)
Central controller
Long distance Alarm and ON/OFF controller
Build-in pump

Extended Performance Data