

SUBMITTAL DATA SHEET



CVH-18-2SH	
Location: _____ Engineer: _____ Submitted to: _____ Submitted by: _____ Reference: _____	Approval: _____ Date: _____ Construction: _____ Unit #: _____ Drawing #: _____

Outdoor unit model CVH-18-2SH

Certified UL

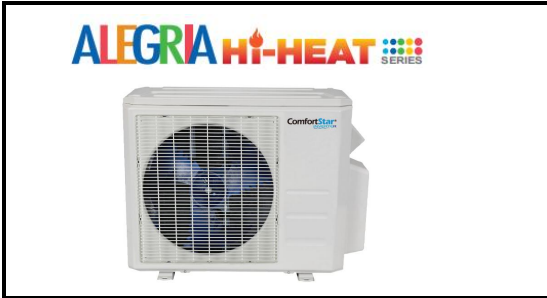

SYSTEM PERFORMANCE DATA

Power supply		
Normal Operational Voltage	(V, Ph, Hz)	208/230, 1, 60
Voltage Range	(V)	187-253
Cooling		
Capacity	Btu/h	19000(5500~25000)
Input	W	1520
Rated current	A	9.1
Heating		
Capacity	Btu/h	20000(8100~29700)
Input	W	1725
Rated current	A	9.4

REFRIGERANT PIPE DATA

Design pressure	(PSIG)	550/340
Refrigerant Type	(Oz)	R410A/91.7
Refrigerant precharge	(ft)	49
	(m)	15.0
Additional charge for each ft-Φ 6.35 (1/4") liquid pipe	(oz/ft)	0.161
Additional charge for each ft-Φ 9.52 (3/8") liquid pipe	(oz/ft)	0.322
Liquid side/ Gas side	(inch)	2 x 1/4"/2 x 3/8"
	(mm)	2 x Φ6.35/2 x Φ9.52
Max. length for all rooms	(ft)	131
Max. length for one indoor unit	(ft)	82.0
Max. height difference between indoor and outdoor unit	(ft)	49
Max. height difference between indoor units	(ft)	33

OUTDOOR UNIT DATA

Compressor		
Model		KTM240D43UKT
Type		ROTARY
Brand		GMCC
Capacity	(Btu/h)	24293.44
Input	(W)	1895
Rated current (RLA)	(A)	-
Refrigerant oil/oil charge	(ml)	VG74/620
Throttle		Capillary +EXV
Air flow & Noise level		
Outdoor air flow (Max.)	(CFM)	2129.41
Outdoor noise level	[dB(A)]	61
Outdoor unit		
Dimension (W×D×H)	(inch)	37.24x16.14x31.89
	(mm)	946x410x810
Packing (W×D×H)	(inch)	42.91x19.69x34.84
	(mm)	1090x500x885
Net/ Gross weight	(lbs.)	138.23/149.03
	(kg)	62.7/67.6
Outdoor (cooling/heating)	(Deg. °F)	-22~122/ -22~86
	(Deg. °C)	-30~50/ -30~30

EER2 (Non-ducted)	12.5	EER2 (Ducted)	12	MIX EER2	12.25
SEER2 (Non-ducted)	22	SEER2 (Ducted)	19	MIX SEER2	20.50
HSPF2-4(Non-ducted)	9.8	HSPF2-4(Ducted)	9.3	MIX HSPF2-4	9.55
HSPF2-5(Non-ducted)	7.7	HSPF2-5(Ducted)	7.5	MIX HSPF2-5	7.60

Outdoor unit dimension

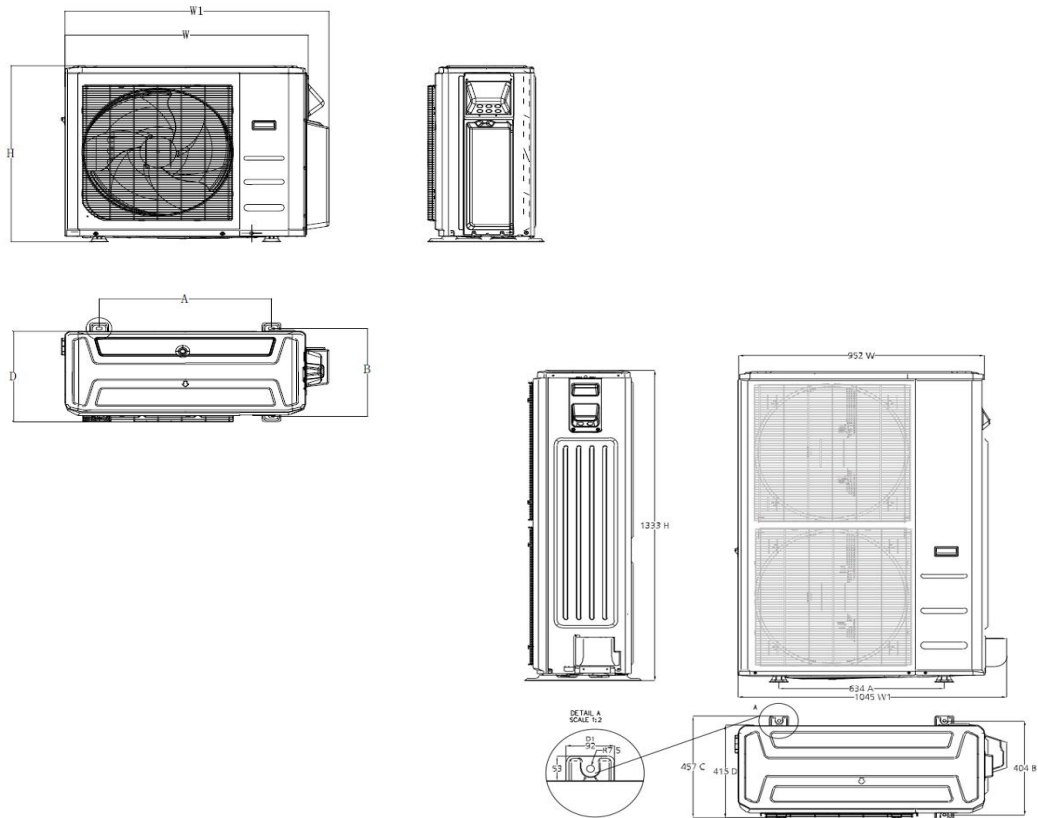

Model	Unit	W	D	H	W1	A	B	C	D
CMZ-18-2Z	mm	890	342	673	990	663	354	/	/
	inch	35.04	13.46	26.5	38.98	26.1	13.94	/	/
CVH-18-2SH	mm	946	410	810	1034	673	403	/	/
CMZ-27-3Z									
CVH-27-3SH	inch	37.24	16.14	31.89	40.6	26.5	15.9	/	/
CMZ-48-4Z									
CVH-36-4SH	mm	952	415	1333	1045	634	404	457	415
CMZ-54-5Z	inch	37.48	16.34	52.48	411.4	249.6	159.1	179.9	163.4
CMZ-60-5Z									
CVH-60-5SH									

24V INTERFACE KIT

