

SUBMITTAL DATA SHEET



<b>TIP48/CHF48CD(O)</b>	<b>48,000 BTU/H(208/230V) Wall Mounted Heat Pump System</b>
Location: _____	Approval: _____
Engineer: _____	Date: _____
Submitted to: _____	Construction: _____
Submitted by: _____	Unit #: _____
Reference: _____	Drawing #: _____

**Set Model**  
 Indoor unit model           TIP48  
 Outdoor unit model       CHF48CD(O)

**Certified**

**AHRI**

**CSA**



SYSTEM PERFORMANCE DATA		
<b>Power supply</b>		
Normal Operational Voltage	(V, Ph, Hz)	208/230, 1, 60
Voltage Range	(V)	187-253
<b>Electrical</b>		
Minimum circuit ampacity	(A)	42
Max.fuse	(A)	50
Connection wiring		14AWG*2 Stranded, shielded
<b>Cooling</b>		
Rated Capacity	(Btu/h)	48000
Capacity Range	(Btu/h)	2700~48900
Power Input (Max)	(W)	6070
Rated current	(A)	25.24
SEER2	(Btu/W)	16.80
EER2	(Btu/W)	8.30
<b>Heating at 47F</b>		
Rated Capacity	(Btu/h)	53000
Capacity Range	(Btu/h)	11800~58000
Power Input (Max)	(W)	4900
Rated current	(A)	21.92
HSPF2-4	(Btu/W)	10.70
HSPF2-5	(Btu/W)	8.50
COP	W/W	3.05

REFRIGERANT PIPE DATA		
Design pressure	(PSIG)	550/340
Refrigerant Type	(Oz)	R410A/148
Refrigerant precharge	(ft)	25.0
	(m)	7.6
Additional charge for each ft	(oz/ft)	0.32
	(g/ft)	30
Liquid side/ Gas side	(inch)	3/8" / 5/8"
	(mm)	9.52/15.9
Max. pipe length	(ft)	213.0
	(m)	65.0
Max. difference in level	(ft)	98.0
	(m)	30.0
Connection method		(Flared)
Indoor(cooling/ heating)	(Deg. °F)	60~90 / 32~86
	(Deg. °C)	16~32 / 0~30
Outdoor(cooling/heating)	(Deg. °F)	-22~122 / -22~75
	(Deg. °C)	-30~50 / -30 ~ 24
Application area	(sq.ft)	688.89~1011.81
	(m2)	64~94

INDOOR UNIT DATA		
<b>Indoor fan motor</b>		
Type		Cross-Flow
Model		ZKFN-125-8-1
Qty		1
Input	(W)	157.0
RLA	(A)	--
LRA	(A)	--
Winding Resistance	(Ω)	--
Capacitor	(uF)	--
Speed(Hi/Mi/Lo)	(r/min)	800/660/590
<b>Air flow &amp; Noise level</b>		
Indoor air flow (Hi/Med/Lo) (No duct)	(CFM)	1171/1059/935
Indoor noise level (Hi/Med/Lo)	[dB(A)]	55/53/50
<b>Dehumidification</b>		
	(Pint/H)	--
<b>Indoor unit</b>		
Dimension (WxDxH)	(inch)	32.68x32.68x11.30
	(mm)	830x830x287
Packing(WxDxH)	(inch)	35.83x35.83x12.99
	(mm)	910x910x330
Net/Gross weight	(lbs.)	64.59/74.07
	(kg)	29.3/33.6

OUTDOOR UNIT DATA		
<b>Compressor</b>		
Type		EAPQ420D1UMUA
Model		ROTARY
Brand		GMCC
Capacity	(Btu/h)	44015
Input	(W)	3565
Rated current (RLA)	(A)	--
Refrigerant oil/oil charge	(ml)	INT01L-4639
Throttle		Capillary +EXV
<b>Outdoor fan motor</b>		
Model		ZKFN-85-8-22-5
Qty		2
Input	(W)	--
RLA	(A)	--
Speed	(r/min)	900/850/800/750
<b>Air flow &amp; Noise level</b>		
Outdoor air flow (Max.)	(CFM)	4500.00
Outdoor noise level	[dB(A)]	65
<b>Outdoor unit</b>		
Dimension (W×D×H)	(inch)	37.48x16.34x52.48
	(mm)	952x415x1333
Packing (W×D×H)	(inch)	43.11x19.49x58.27
	(mm)	1095x495x1480
Net/ Gross weight	(lbs.)	227.07/255.73
	(kg)	103/116

### Indoor unit dimension

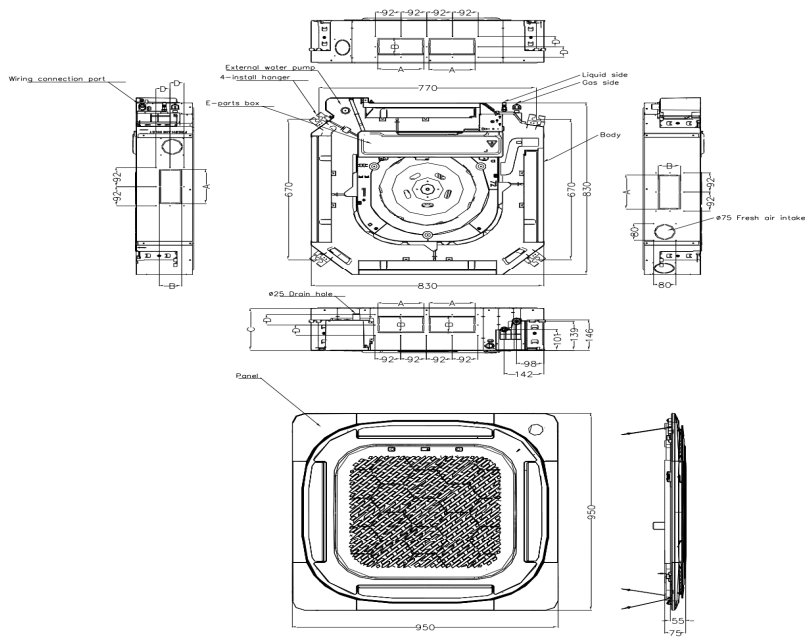

Capacity (Btu/h)	Unit	A	B	C	D
24K	mm	165	80	205	50
	inch	6.5	3.15	8.07	1.97
36K	mm	165	100	245	60
	inch	6.5	3.64	9.65	2.36
48K	mm	165	100	287	60
	inch	6.5	3.64	11.30	2.36

### Outdoor unit dimension

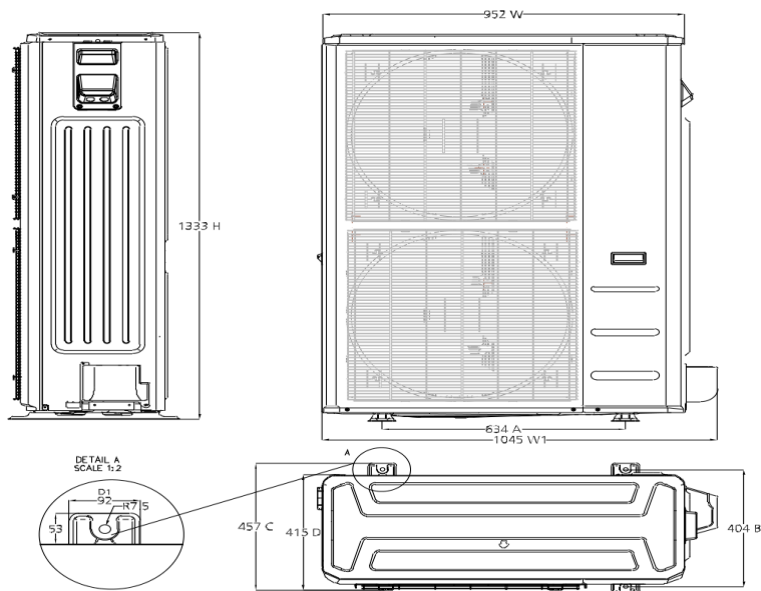

**General Features**

Wireless Remote with LCD Display  
Follow Me  
Sleep  
Timer  
Self Clean  
46F Heating  
Silent

**Extended Performance Data**