

SUBMITTAL DATA SHEET



TIP-48/CZP48CD (O)	48,000 BTU/H(208/230V)	Wall Mounted Heat Pump System
Location: _____	Approval: _____	
Engineer: _____	Date: _____	
Submitted to: _____	Construction: _____	
Submitted by: _____	Unit #: _____	
Reference: _____	Drawing #: _____	

Set Model
 Indoor unit model TIP-48
 Outdoor unit model CZP48CD(O)

Certified

AHRI

CSA

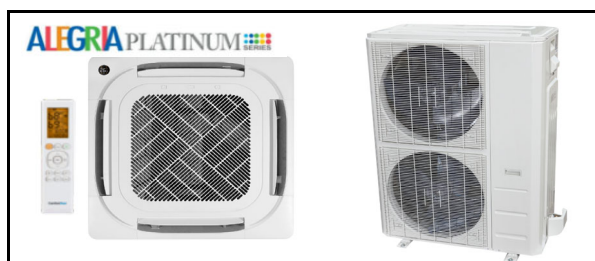

SYSTEM PERFORMANCE DATA

Power supply

Normal Operational Voltage	(V, Ph, Hz)	208/230, 1, 60
Voltage Range	(V)	187-253

Electrical

Minimum circuit ampacity	(A)	36.5
Max.fuse	(A)	50.0
Connection wiring		14AWG*2 Stranded, shielded

Cooling

Rated Capacity	(Btu/h)	48000
Capacity Range	(Btu/h)	16600~48000
Power Input (Max)	(W)	5053
Rated current	(A)	23.1
SEER2	(Btu/W)	18.50
EER2	(Btu/W)	9.50

Heating at 47F

Rated Capacity	(Btu/h)	50000
Capacity Range	(Btu/h)	11850~52000
Power Input (Max)	(W)	4727
Rated current	(A)	21.6
HSPF2-4	(Btu/W)	9.80
HSPF2-5	(Btu/W)	7.50
COP	W/W	3.10

Heating at 17F

Max Capacity	(Btu/h)	0
--------------	---------	---

REFRIGERANT PIPE DATA

Design pressure	(PSIG)	550/340
Refrigerant Type	(Oz)	R410A/158.7
Refrigerant precharge	(ft)	25.0
	(m)	7.6
Additional charge for each ft	(oz/ft)	0.32
	(g/ft)	30
Liquid side/ Gas side	(inch)	3/8" / 5/8"
	(mm)	9.52/15.9
Max. pipe length	(ft)	213.0
	(m)	65.0
Max. difference in level	(ft)	98.0
	(m)	30.0
Connection method		(Flared)

Indoor(cooling/ heating)	(Deg. °F)	60~90 / 32~86
	(Deg. °C)	16~32 / 0~30
Outdoor(cooling/heating)	(Deg. °F)	5~122 / 5~75
	(Deg. °C)	-15~50 / -15~24
Application area	(sq.ft)	688.89~1011.81
	(m2)	64~94

INDOOR UNIT DATA

Indoor fan motor

Type		Cross-Flow
Model		ZKFN-125-8-1
Qty		1
Input	(W)	157.0
RLA	(A)	-
LRA	(A)	---
Winding Resistance	(Ω)	---
Capacitor	(uF)	---
Speed(Hi/Mi/Lo)	(r/min)	800/660/590

Air flow & Noise level

Indoor air flow (Hi/Med/Lo) (No duct)	(CFM)	1171/1059/935
Indoor noise level (Hi/Med/Lo)	[dB(A)]	55/53/50

Dehumidification (Pint/H) ---

Indoor unit

Dimension (WxDxH)	(inch)	32.68x32.68x11.30
	(mm)	830x830x287
Packing(WxDxH)	(inch)	35.83x35.83x12.99
	(mm)	910x910x330
Net/Gross weight	(lbs.)	64.59/74.07
	(kg)	29.3/33.6

OUTDOOR UNIT DATA

Compressor

Type		KTQ420D1UMU
Model		ROTARY
Brand		GMCC
Capacity	(Btu/h)	44697
Input	(W)	3420
Rated current (RLA)	(A)	-
Refrigerant oil/oil charge	(ml)	INT01L-4639
Throttle		Capillary +EXV

Outdoor fan motor

Model		ZKFN-85-8-22
Qty		2
Input	(W)	--
RLA	(A)	--
Speed	(r/min)	900/850/800/750

Air flow & Noise level

Outdoor air flow (Max.)	(CFM)	4500.00
Outdoor noise level	[dB(A)]	63.5

Outdoor unit

Dimension (WxDxH)	(inch)	37.48x16.34x52.48
	(mm)	952x415x1333
Packing (WxDxH)	(inch)	43.11x19.49x58.27
	(mm)	1095x495x1480
Net/ Gross weight	(lbs.)	219.14/249.12
	(kg)	99.4/113

Indoor unit dimension

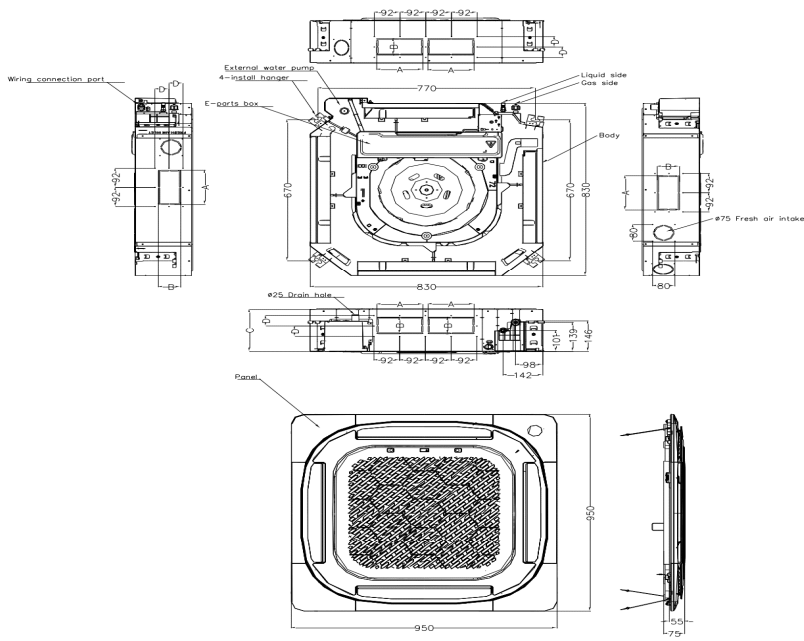

Capacity (Btu/h)	Unit	A	B	C	D
24K	mm	165	80	205	50
	inch	6.5	3.15	8.07	1.97
36K	mm	165	100	245	60
	inch	6.5	3.64	9.65	2.36
48K	mm	165	100	287	60
	inch	6.5	3.64	11.30	2.36

Outdoor unit dimension

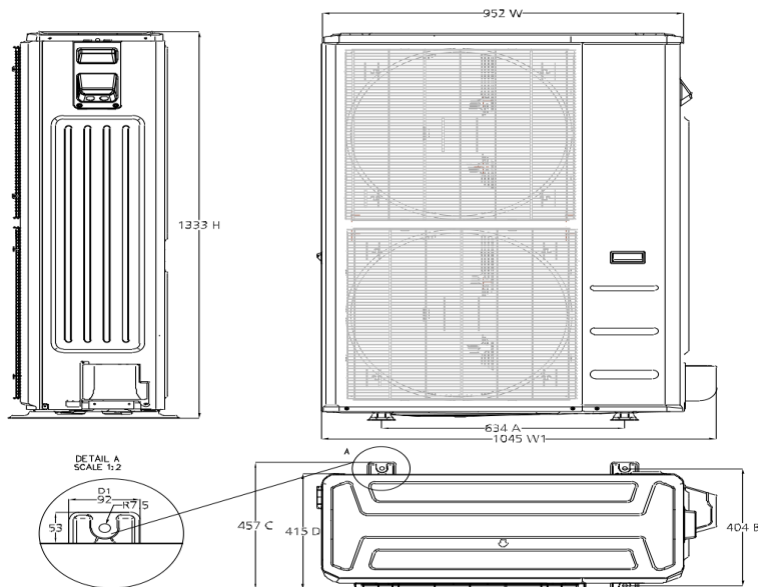

General Features

Wireless Remote with LCD Display

Follow Me

Sleep

Timer

Self Clean

46F Heating

Silent

Extended Performance Data