



Submittal

Split System Cooling

CWM4-18-15

Location: _____
Engineer: _____
Submitted to: _____
Submitted by: _____
Reference: _____

Approval: _____
Date: _____
Construction: _____
Unit # : _____
Drawing # : _____



Note: " Graphics in this document are for representation only. Actual model may differ in appearance. "

Unit dimension

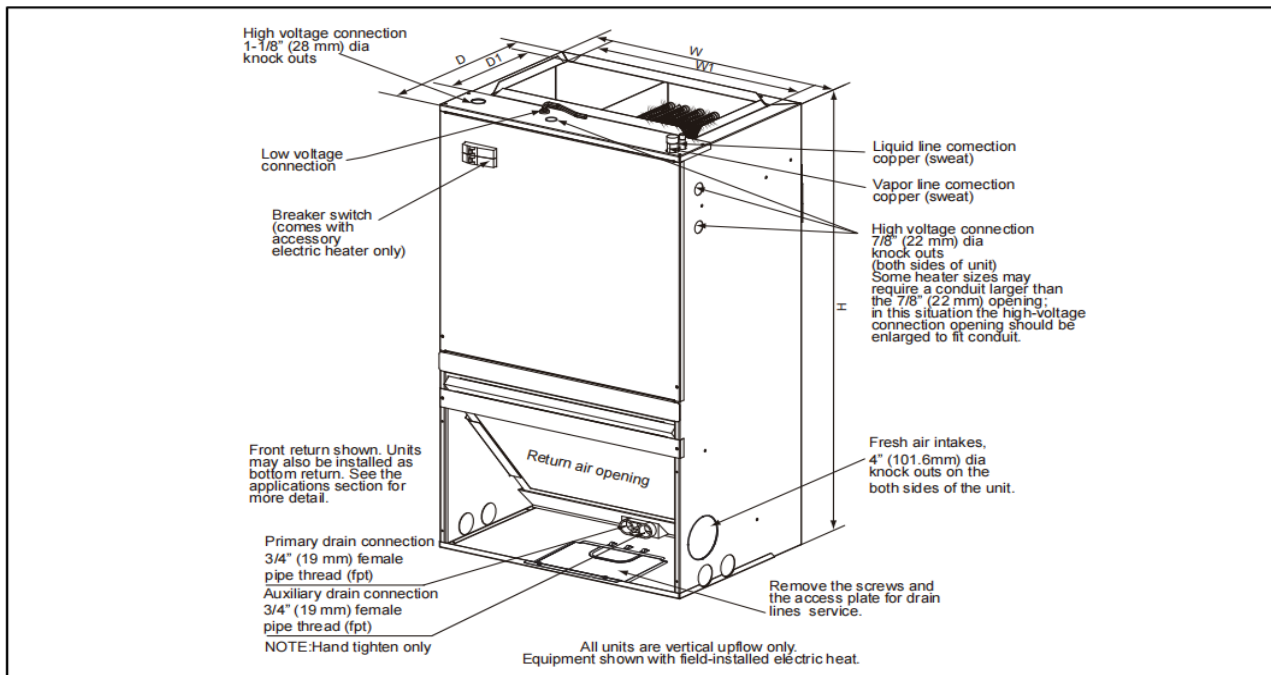

Model	Dimensions [IN.]					Unit Weight/Shipping Weight Lbs.
	Unit Height "H" IN.	Unit Width "W" IN.	Unit Width "W1" IN.	Unit Depth "D" IN.	Unit Depth "D1" IN.	
18K/24K	36-1/2	20-1/2	17-2/5	15	9-1/2	92/101
30K/36K	39-1/2	21-9/10	18-4/5	17-1/2	9-1/2	97/119

Specification

Model		CWM4-18-15	
Indoor fan motor	Type	ECM	
	Power supply	AC220-240V/50 60Hz	
	Model	DZJ-249F-12	
	Output	W	249
	rate current	A	2.4
	Speed	rpm	1050
Static pressure		Pa	75
Indoor air flow		CFM	626
Indoor noise level		dB(A)	48.5
Throttling type		Piston	
Indoor coil	Evaporator type	Copper tube&Aluminum foil	
	Number of row	5 rows 11u	
	Tube pitch(a)xrow pitch(b)	in	0.83×0.53
	Fin spacing	in	1/17
	Evaporator dimension	in	17"×18-1/5"×2-3/5"
Indoor dimension	Unit dimension (W*D*H)	in	20-1/2"×15"×36-1/2"
		mm	520×381×927
		in	23-3/7"×17-1/2"×39-1/2"
		mm	595×445×1005
	Net / Gross weight	kg	37/41.5
		lbs	88/101

Outdoor Unit	Indoor Unit	Cooling Capacity	EER2	SEER2
BAR4-18-15	CWM4-18-15	19000	11.7	14.3

Electric Heater Kits

NO.	Kit#	Description	Ref. Air Handler use
1	05	5kW Heat Strip	18,24,30,36,42,48,60
2	08	7.5kW Heat Strip	18,24,30,36,42,48,60
3	10	10kW Heat Strip	18,24,30,36,42,48,60
4	05B	Circuit Breaker, 5kW Heat Strip	18,24,30,36,42,48,60
5	08B	Circuit Breaker, 7.5kW Heat Strip	18,24,30,36,42,48,60
6	10B	Circuit Breaker, 10kW Heat Strip	18,24,30,36,42,48,60
7	15B	Circuit Breaker, 15kW Heat Strip	36,42,48,60
8	20B	Circuit Breaker, 20kW Heat Strip	36,42,48,60

MCA/MOP DATA

Heat Kit Model	Air Handler Model	(kW)Electric Heat	MIN. Circuit Ampacity		MAX.Fuse or Breaker (HACR) Ampacity	
			240	208	240	208
05(B)	18	5	21	18	30	30
08(B)		7.5	32	28	50	50
10(B)		10	42	36	60	60
05(B)	24	5	21	18	30	30
08(B)		7.5	32	28	50	50
10(B)		10	42	36	60	60
05(B)	30	5	21	18	30	30
08(B)		7.5	32	28	50	50
10(B)		10	42	36	60	60
05(B)	36	5	21	18	30	30
08(B)		7.5	32	28	50	50
10(B)		10	42	36	60	60
15B		15	64	56	30+60	30+60
20B		20	84	72	60+60	60+60
05(B)	42	5	21	18	30	30
08(B)		7.5	32	28	50	50
10(B)		10	42	36	60	60
15B		15	64	56	30+60	30+60
20B		20	84	72	60+60	60+60
05(B)	48	5	21	18	30	30
08(B)		7.5	32	28	50	50
10(B)		10	42	36	60	60
15B		15	64	56	30+60	30+60
20B		20	84	72	60+60	60+60
05(B)	60	5	21	18	30	30
08(B)		7.5	32	28	50	50
10(B)		10	42	36	60	60
15B		15	64	56	30+60	30+60
20B		20	84	72	60+60	60+60

ComfortStar®

12201 N W 107th Avenue
Miami, FL 33178
1.866.524.9898 Toll Free
305.500.9898 Office
305.500.9896 Fax
<http://www.comfortstarusa.com>



The AHRI mark indicates Comfortstar participating in the AHRI Certification program. Visit ahridirectory.org for verification of individual certified products. Comfortstar reserves the right to change design and specs without notice. Comfortstar has a policy of update the data continuously. We are committed to using environmentally conscious print practices.

CWM4-18-15 11 Nov 2022
Supersedes CWM4-18-15 (Nov.2022)

© 2022 ComfortStar