

# SUBMITTAL DATA SHEET

## ComfortStar®

### CARAT18CD-M

Location: \_\_\_\_\_  
 Engineer: \_\_\_\_\_  
 Submitted to: \_\_\_\_\_  
 Submitted by: \_\_\_\_\_  
 Reference: \_\_\_\_\_

Approval: \_\_\_\_\_  
 Date: \_\_\_\_\_  
 Construction: \_\_\_\_\_  
 Unit #: \_\_\_\_\_  
 Drawing #: \_\_\_\_\_

#### Set Model

Indoor unit model CARAT18CD(I)-M  
 Outdoor unit model CARAT18CD(O)-M

#### Certified

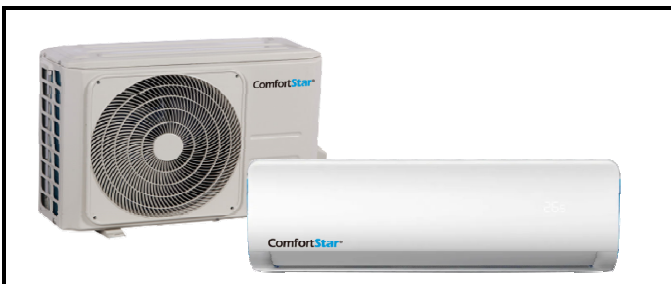

### SYSTEM PERFORMANCE DATA

<b>Power supply</b>		
Voltage Range	(V)	208-230V, 1Ph, 60Hz
<b>Electrical</b>		
Rated Power Input	W	2950
Rated Current	(A)	13.5
Starting current	(A)	/
<b>Cooling</b>		
Capacity	(Btu/h)	17500
Input	(W)	1570
Current	(A)	6.8
SEER2		21.0
SEER		21.0
EER2		11.3
EER		11.3

### INDOOR UNIT DATA

<b>Indoor fan motor</b>		
Type		Cross-Flow
Model		ZKFP-30-8-3-10
Qty		1
Input	(W)	36
Capacitor	(uF)	/
Speed(Hi/Mi/Lo)	(r/min)	1200/650
<b>Air flow &amp; Noise level</b>		
Indoor air flow (Hi/Med/Lo) (No duct)	(m <sup>3</sup> /h)	800/600/520
Indoor noise level (Hi/Med/Lo)	[dB(A)]	46/38.5/31.5
<b>Indoor unit</b>		
Dimension (WxDxH)	(inch)	38.2x9.0x12.6
	(mm)	971x228x321
Packing(WxDxH)	(inch)	41.1x12.0x15.9
	(mm)	1045x305x405
Net/Gross weight	(lbs.)	24.7/31.7
	(kg)	11.2/14.4

### REFRIGERANT PIPE DATA

Refrigerant Type	(kg)	R410A/0.9
Liquid side/ Gas side	(inch)	
	(mm)	
Max. pipe length	(ft)	98.0
	(m)	30
Max. difference in level	(ft)	65.6
	(m)	20
Indoor(cooling/ heating)	(Deg. °F)	60~90//
	(Deg. °C)	16~32//
Outdoor(cooling/heating)	(Deg. °F)	32~122//
	(Deg. °C)	0~50//
Application area	(sq.ft)	247.6~366.0
	(m <sup>2</sup> )	23~34

### OUTDOOR UNIT DATA

<b>Compressor</b>		
Type		ROTARY
Model		KSN140D58UFZ
Brand		GMCC
Capacity	(Btu/h)	4315
Input	(W)	1090
Rated current (RLA)	(A)	7.15
<b>Thermostat type</b>		
		Remote Control
<b>Outdoor fan motor</b>		
Model		ZKFN-34-10-1-3
Qty		1
Input	(W)	98.50
RLA	(A)	--
Speed	(r/min)	810/700/600
<b>Air flow &amp; Noise level</b>		
Outdoor air flow (Max.)	(m <sup>3</sup> /h)	2100
Outdoor noise level	[dB(A)]	55.5
<b>Outdoor unit</b>		
Dimension(W*D*H)	(inch)	30.1x11.9x21.9
	(mm)	765x303x555
Packing (W*D*H)	(inch)	34.9x13.2x24.0
	(mm)	887x337x610
Net/ Gross weight	(lbs.)	61.5/66.8
	(kg)	27.9/30.3

Indoor unit dimension

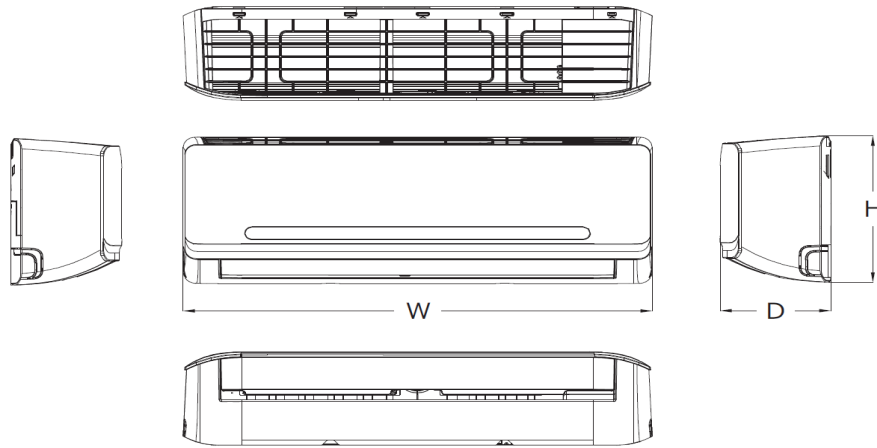

Dimension(mm)	W	D	H
CARAT12CA(I)-M	802	200	295
CARAT12CD(I)-M	802	200	295
CARAT18CD(I)-M	971	228	321
CARAT24CD(I)-M	1082	234	337
CARAT36CD(I)-M	1259	283	362

Outdoor unit dimension

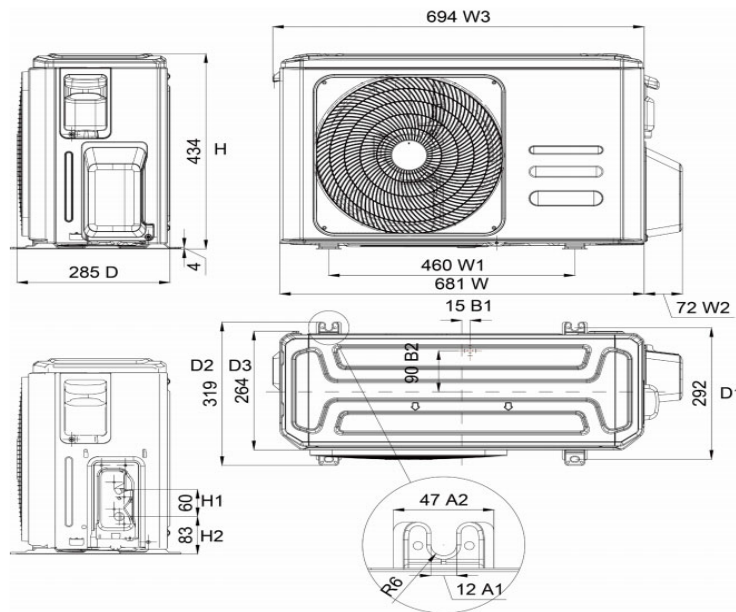

Dimension(mm)	W	D	H
CARAT12CA(O)-M	720	270	495
CARAT12CD(O)-M	720	270	495
CARAT18CD(O)-M	765	303	555
CARAT24CD(O)-M	805	303	554
CARAT36CD(O)-M	946	410	810