

SUBMITTAL DATA SHEET

ComfortStar®

CARAT24CD-M	
Location: _____ Engineer: _____ Submitted to: _____ Submitted by: _____ Reference: _____	Approval: _____ Date: _____ Construction: _____ Unit #: _____ Drawing #: _____

Set Model	
Indoor unit model	CARAT24CD(I)-M
Outdoor unit model	CARAT24CD(O)-M
Certified	AHRI  UL 



SYSTEM PERFORMANCE DATA		
Power supply		
Voltage Range	(V)	208-230V, 1Ph, 60Hz
Electrical		
Rated Power Input	W	2850
Rated Current	(A)	13.5
Starting current	(A)	/
Cooling		
Capacity	(Btu/h)	22000
Input	(W)	2150
Current	(A)	9.3
SEER2		20.0
SEER		20.0
EER2		10.2
EER		10.2

INDOOR UNIT DATA		
Indoor fan motor		
Type		Cross-Flow
Model		ZKFP-58-8-1-5
Qty		1
Input	(W)	58
Capacitor	(uF)	/
Speed(Hi/Mi/Lo)	(r/min)	1100/650
Air flow & Noise level		
Indoor air flow (Hi/Med/Lo) (No duct)	(m3/h)	1000/800/680
Indoor noise level (Hi/Med/Lo)	[dB(A)]	47.5/39.5/36
Indoor unit		
Dimension (WxDxH)	(inch)	42.6x9.2x13.3
	(mm)	1082x234x337
Packing(WxDxH)	(inch)	45.5x16.3x12.4
	(mm)	1155x415x315
Net/Gross weight	(lbs.)	30.0/37.7
	(kg)	13.6/17.1

REFRIGERANT PIPE DATA		
Refrigerant Type	(kg)	R410A/37.74
Liquid side/ Gas side	(inch)	
	(mm)	
Max. pipe length	(ft)	98.0
	(m)	30
Max. difference in level	(ft)	65.6
	(m)	20
Indoor(cooling/ heating)	(Deg. °F)	60~90//
	(Deg. °C)	16~32//
Outdoor(cooling/heating)	(Deg. °F)	32~122//
	(Deg. °C)	0~50//
Application area	(sq.ft)	312.2~462.9
	(m2)	29~43

OUTDOOR UNIT DATA		
Compressor		
Type		ROTARY
Model		KSN140D58UFZ
Brand		GMCC
Capacity	(Btu/h)	4315
Input	(W)	1090
Rated current (RLA)	(A)	7.15
Thermostat type		
		Remote Control
Outdoor fan motor		
Model		ZKFN-34-10-1-3
Qty		1
Input	(W)	98.50
RLA	(A)	--
Speed	(r/min)	810/700/550
Air flow & Noise level		
Outdoor air flow (Max.)	(m3/h)	2300
Outdoor noise level	[dB(A)]	56.5
Outdoor unit		
Dimension(W*D*H)	(inch)	31.7x13.0x21.8
	(mm)	805x330x554
Packing (W*D*H)	(inch)	36.0x14.6x24.2
	(mm)	915x370x615
Net/ Gross weight	(lbs.)	67.2/73.0
	(kg)	30.5/33.1

Indoor unit dimension

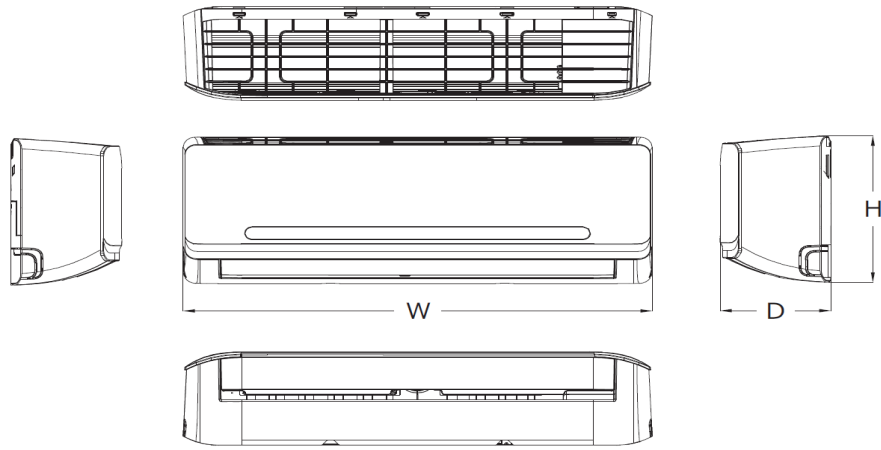

Dimension(mm)	W	D	H
CARAT12CA(I)-M	802	200	295
CARAT12CD(I)-M	802	200	295
CARAT18CD(I)-M	971	228	321
CARAT24CD(I)-M	1082	234	337
CARAT36CD(I)-M	1259	283	362

Outdoor unit dimension

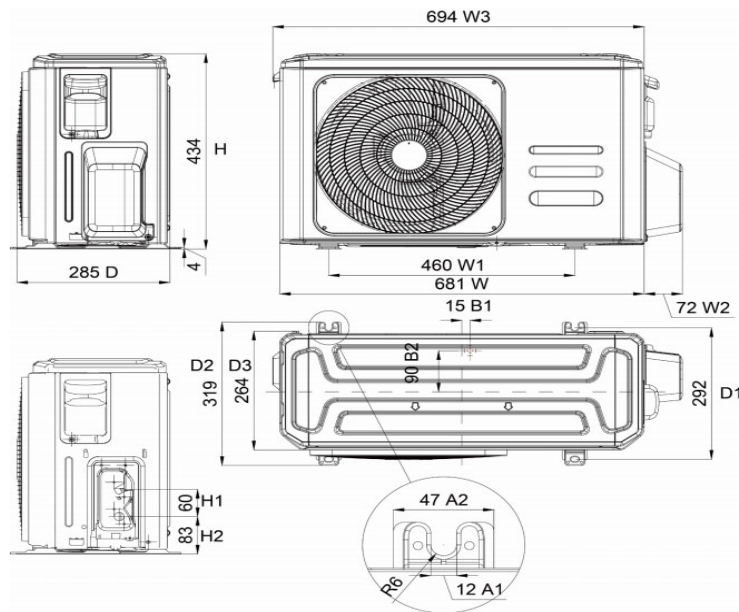

Dimension(mm)	W	D	H
CARAT12CA(O)-M	720	270	495
CARAT12CD(O)-M	720	270	495
CARAT18CD(O)-M	765	303	555
CARAT24CD(O)-M	805	303	554
CARAT36CD(O)-M	946	410	810