

SUBMITTAL DATA SHEET

ComfortStar®

CARAT36CD-M	
Location: _____ Engineer: _____ Submitted to: _____ Submitted by: _____ Reference: _____	Approval: _____ Date: _____ Construction: _____ Unit #: _____ Drawing #: _____

Set Model
 Indoor unit model CARAT36CD(I)-M
 Outdoor unit model CARAT36CD(O)-M

Certified

AHRI	
UL	

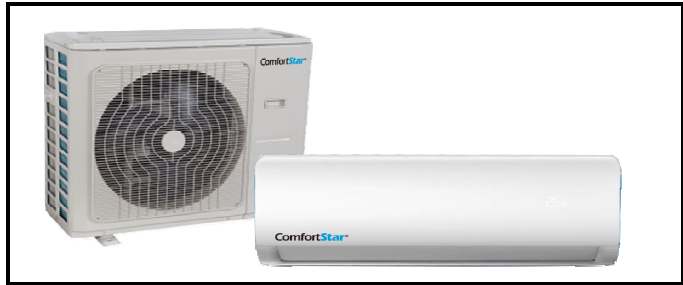

SYSTEM PERFORMANCE DATA		
Power supply		
Voltage Range	(V)	208/230V, 1Ph, 60Hz
Electrical		
Rated Power Input	W	4800
Rated Current	(A)	21
Starting current	(A)	/
Cooling		
Capacity	(Btu/h)	36000
Input	(W)	3790
Current	(A)	16.8
SEER2		18.0
SEER		18.0
EER2		9.5
EER		9.5
Heating		
Capacity (range)		36000(10900~37360)
Input		3790(610~3720)
Current		16.8(2.66~16.2)
HSPF2-4		12
HSPF2-5		9

INDOOR UNIT DATA		
Indoor fan motor		
Type		Cross-Flow
Model		ZKFP-58-8-1-5
Qty		1
Input	(W)	58
Capacitor	(uF)	/
Speed(Hi/Mi/Lo)	(r/min)	1200/960/600
Air flow & Noise level		
Indoor air flow (Hi/Med/Lo) (No duct)	(m3/h)	1110/760/560
Indoor noise level (Hi/Med/Lo)	[dB(A)]	54/45/40
Indoor unit		
Dimension (WxDxH)	(inch)	49.6x11.1x14.3
	(mm)	1259x283x362
Packing(WxDxH)	(inch)	52.8x17.7x15.2
	(mm)	1340x450x385
Net/Gross weight	(lbs.)	42.8/55.6
	(kg)	19.4/25.2

REFRIGERANT PIPE DATA		
Refrigerant Type	(kg)	R410A/3.40
Liquid side/ Gas side	(inch)	
	(mm)	
Max. pipe length	(ft)	213.0
	(m)	65
Max. difference in level	(ft)	98.0
	(m)	30
Indoor(cooling/ heating)	(Deg. °F)	60~90/32~86
	(Deg. °C)	16~32/0~30
Outdoor(cooling/heating)	(Deg. °F)	5~122/5~75
	(Deg. °C)	-15~50/-15~24
Application area	(sq.ft)	516.7~753.5
	(m2)	48~70

OUTDOOR UNIT DATA		
Compressor		
Type		ROTARY
Model		KTF250D22UMT
Brand		GMCC
Capacity	(Btu/h)	8095
Input	(W)	2200
Rated current (RLA)	(A)	10
Thermostat type		
		Remote Control
Outdoor fan motor		
Model		ZKFN-120-8-2
Qty		1
Input	(W)	150
RLA	(A)	--
Speed	(r/min)	1150/1050/900/850
Air flow & Noise level		
Outdoor air flow (Max.)	(m3/h)	3800
Outdoor noise level	[dB(A)]	65
Outdoor unit		
Dimension(W*D*H)	(inch)	37.2x16.1x31.9
	(mm)	946x410x810
Packing (W*D*H)	(inch)	42.9x19.7x34.8
	(mm)	1090x500x885
Net/ Gross weight	(lbs.)	150.1/159.0
	(kg)	68.1/72.1

Indoor unit dimension

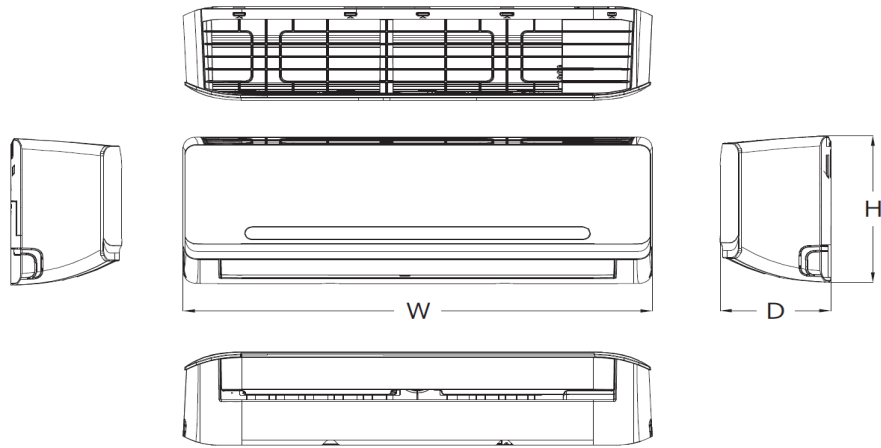

Dimension(mm)	W	D	H
CARAT12CA(I)-M	802	200	295
CARAT12CD(I)-M	802	200	295
CARAT18CD(I)-M	971	228	321
CARAT24CD(I)-M	1082	234	337
CARAT36CD(I)-M	1259	283	362

Outdoor unit dimension

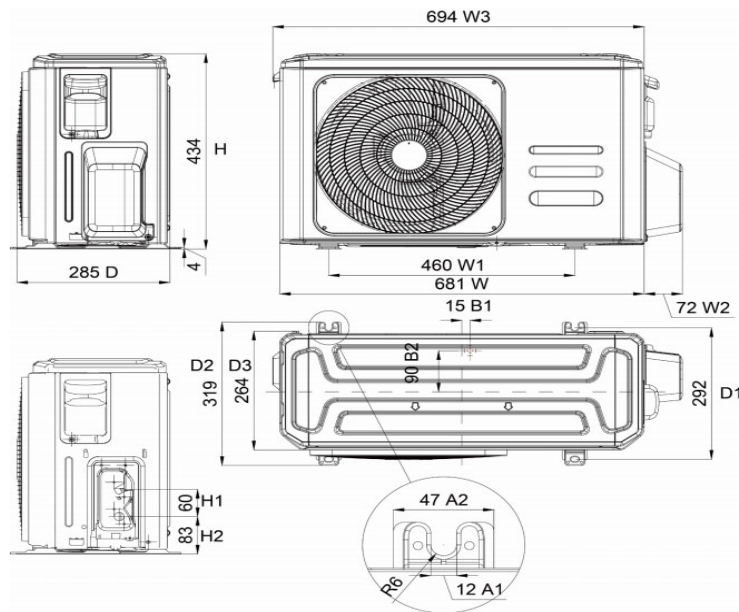

Dimension(mm)	W	D	H
CARAT12CA(O)-M	720	270	495
CARAT12CD(O)-M	720	270	495
CARAT18CD(O)-M	765	303	555
CARAT24CD(O)-M	805	303	554
CARAT36CD(O)-M	946	410	810