

# Exploded View

Model

CHF60CD(O)

ComfortStar®

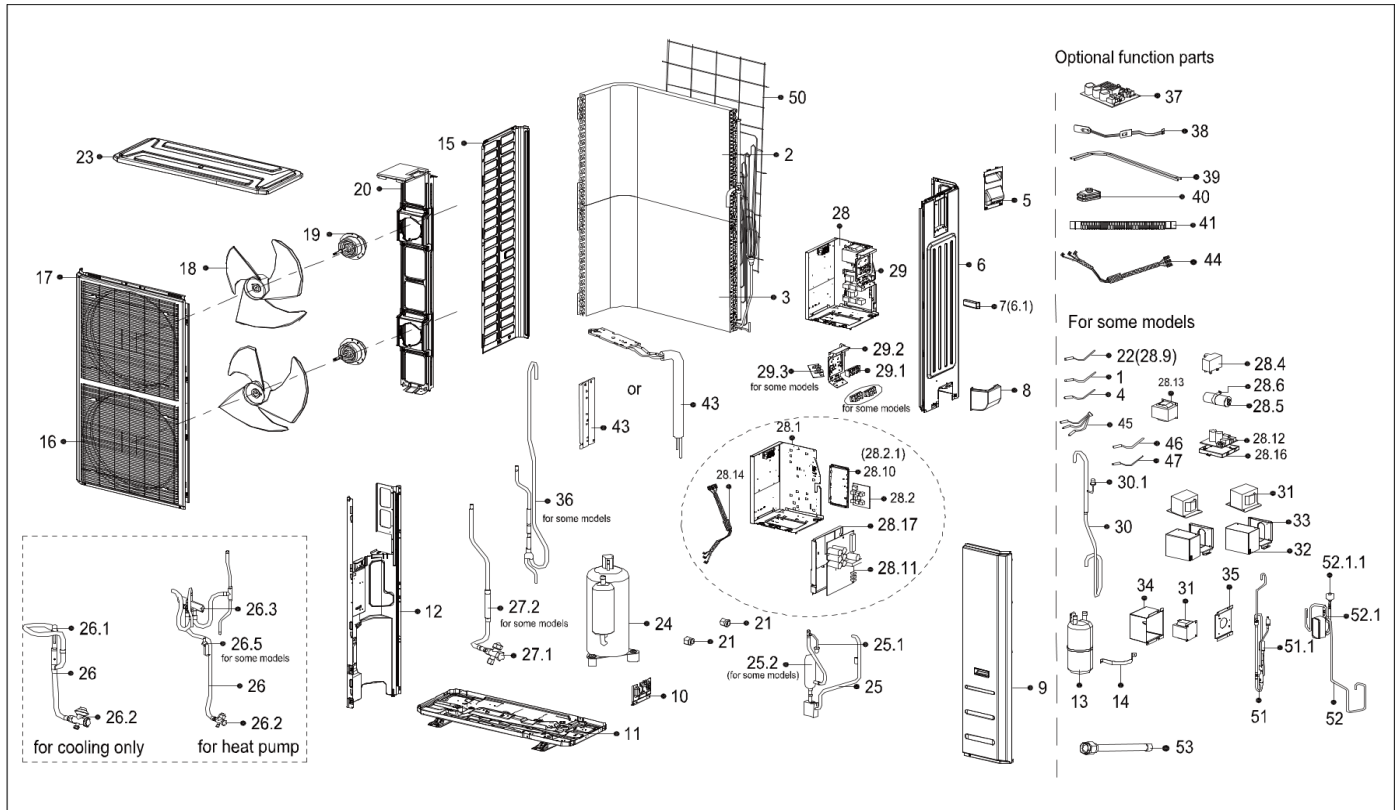

EX_ID	Spare Parts Code	Part Name(EN)	Qty.	Price	Remarks
1	11201007003448	Room Temperature Sensor	1		
2	15822000013007	Condenser assembly	1		
3	15822000013486	Condenser assembly	1		
4	11201007003441	Pipe Temperature Sensor	1		
5	12222000013365	Big handle assembly	1		
6	12222000012373	Rear right clapboard assembly	1		
6.1	12100702000038	handle	1		
8	12122000014023	Water collector	1		
9	12222000006287	Front right clapboard assembly	1		

10	12222200002361	Valve plate	1		
11	12222000013910	Chassis assembly	1		
12	12222000017025	Partition board assembly	1		
13	15500508001475	Liquid-storage tank	1		
15	12222200002363	Left side plate assembly of cabinet	1		
16	12222000014845	Air outlet grille	2		
17	12222000007564	Front panel	1		
18	12100105000022	Axial flow fan	2		
19	11002015009825	Brushless DC Motor	2		
20	12222000016092	Supporter subassembly of fan motor	1		
21	15500406000010	Copper nut	1		
22	11201007003124	Discharge Temperature Sensor	1		
23	12222200002359	Top cover assembly	1		
24	11103020006399	DC Inverter Rotary Compressor	1		
25	15122000031463	Discharge pipe assembly	1		
25.1	17400516000851	Pressure switch	1		
26	15422000022898	4-way valve assembly	1		
26.2	15500204000027	Gas valve	1		
26.3	15500216000681	4-way valve	1		
27	15422000022916	Liquid valve assembly	1		
27.1	15500204000021	Gas valve	1		
27.2	15500210004208	Throttle valve	1		
28	17222000040227	Electronic control box subassembly	1		
28.1	12222000012372	Installation plate of electric parts subassembly	1		
28.2	17122000055266	Inverter module subassembly	1		
28.10	12122000014342	Electronic installing box	1		
28.11	17122000058476	Outdoor main control board subassembly	1		
28.14	17401203022090	Compressor wire subassembly	1		
28.17	12122000020943	Electronic installing box	1		
29	17222000031002	Terminal board subassembly	1		
29.1	17400401003456	Wire joint	1		
29.1	17400401000098	Terminal	1		
29.1	17400401000085	Wire joint	1		
29.2	12222000012265	Terminal instalation subassembly	1		

30	15122000031459	Suction pipe assembly	1		
30.1	17400516000009	Pressure switch	1		
38	17402001000602	Crankcase electric heating strip	1		
39	17402002000466	Electric heating tube	1		
43	15122000031462	Radiator subassembly	1		
50	12222000007944	Rear net	1		
51	15422000022897	Electronic expansion valve subassembly	1		
51.1	15500213000245	Electronic expansion valve	1		
52	15700101001416	Plate heat exchanger subassembly	1		
52.1	15422000022915	Electronic expansion valve subassembly	1		
52.1.1	15500213000865	Electric expansive valve	1		