

Accessory part

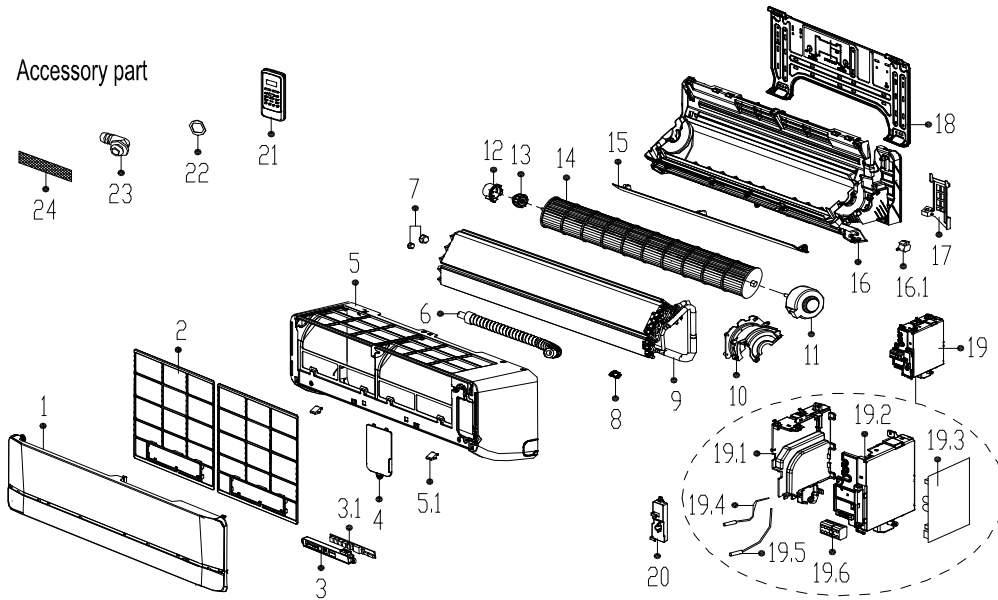

Optional part

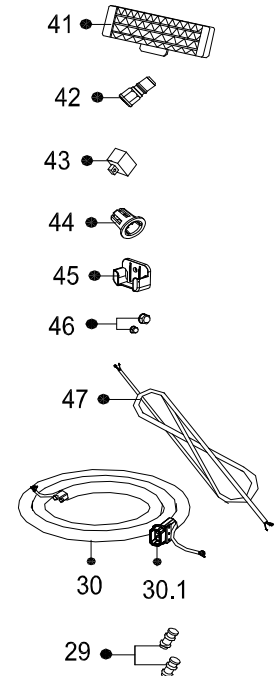

No.	Part Name	Quantity	PART#
1	Panel Assembly	1	12122000A67327
2	Air Filter	2	A325A5346
3	Display Box Subassembly	1	17222000A55435
3.1	Display Board Subassembly	1	17122000A14189
4	Cover Of Electrical Equipment	1	A19901024
5	Panel Frame Assembly	1	12122000A50699
5.1	Screw Cap	2.0	A19900950
6	Drain Hose1	1	A32300999
7	Pipe Nut	1	F00300775
7	Copper Nut1	1	F00320001
7	Copper Nut2	1	F00320000
8	Fixed Clamp Of Temperature Sensor	1	A02000305
9	Evaporator Assembly	1	15822000008163
10	Fan Motor Cover	1	12122000019981
11	Brushless Dc Motor	1	N00300017
12	Bearing Holder	1	A19900952
13	Bearing Base	1	Q19900606
14	Cross Flow Fan	1	A00200054
15	Horizontal Louver Assembly	1	12122000A54652
16	Chassis Assembly	1	12122000A61795
16.1	Stepper Motor	1.0	N00200031
17	Pipe Clamp Board	1	A19991000
18	Installation Plate	1	B325A0010
19	Electronic Control Box Subassembly (Mid-And Low-End)	1	17222000028262
19.3	Main Control Board Subassembly	1	17122000044836
19.4	Room Temperature Sensor	1	N33190000
19.5	Pipe Temperature Sensor	1	M01300426
19.6	Terminal	1	M01400488
20	Cover Of Electronic Control Box	1	A32591086
21	Remote Controller	1	17317000A16345
22	Seal Ring	1	Q20090001
23	Drain Hose2	1	A01020011
24	Air Freshening Filter	1	A30100212
42	Check Valve	1	F01600099
45	Bracket Of Remote Controller	1	12117000002116