

Model: AHH60-410-C
 Power supply: 208/230V_1Ph_60HZ

ComfortStar®

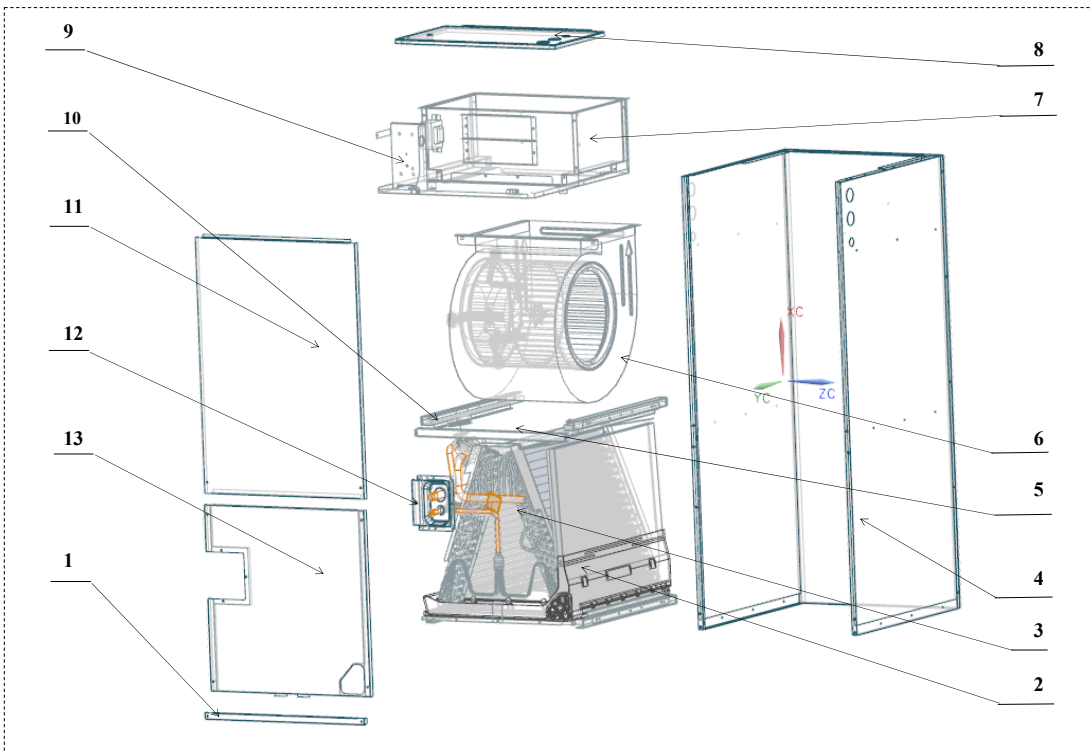
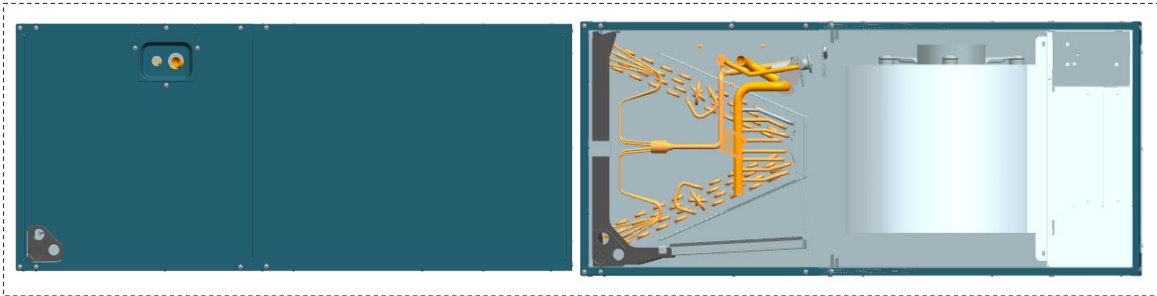

No.	Part Name	Quantity	Sale code	BOM code	Remark
1	Filter Cover plate	1		801239390088	
2	Water pan components	1		801239390029	
2.1	Water pan# 1	1		801139390001	
2.2	Water pan# 2	1		801139390002	
2.3	Water pan fixed block	1		801234590091	
2.4	Water pan brace	2		801234190193	
3	Evaporator welding components	1		801539390025	
3.1	Air header Assembly	1		801634590028	
3.2	Diverter Assembly	1		801634590027	
3.3	Evaporator A	1		801534590028	
3.4	Evaporator B	1		801534590029	
3.5	Evaporator C	1		801534590030	
3.6	Evaporator D	1		801534590031	
3.7	Evaporator Baffle	2		801239390052	
3.8	Evaporator Water Baffle #1	2		801234590095	
3.9	Evaporator Water Baffle #2	1		801234590096	
3.10	Evaporator Water Baffle #3	1		801234590097	
3.11	Evaporator Fixing Plate #1	1		801239390053	

3.12	Evaporator Fixing Plate #2	1		801239390056		
3.13	Evaporator Junction Plate	1		801239390054		
4	Chassis assembly	1		801239390045		
5	Supporter	2		801239390051		
6.1	Right Volute Wind Wheel	1		801200200040		
6.2	Indoor Motor	1		802400400763		
7	Fan Motor Fixing plate assembly	1		801239390057		
7.1	Fan Motor Fixing plate	1		801239390089		
7.2	Wind Wheel Fixed Block	2		801234590106		
7.3	Fixed plate on air duct	1		801239390090		
7.4	Stator	2		801239390056		
7.5	air duct left stationary plate	1		801239390023		
7.6	air duct right stationary plate	1		801239390024		
8	Electric control box cover assembly	1		801239390060		
9	Electronic Control Components	1		803339390019		
9.1	Electronic Control Mounting Plate	1		801234590202		
9.2	Main Board	1		803339390018		
9.3	Transformer	1		802300200087		
10	Water pan supporter assembly	4		801239390082		
11	Upper side plate assembly	1		801239390046		
12	Pipe Cover plate assembly	1		801234590081		
13	Lower side plate assembly	1		801239390048		

