

# SUBMITTAL DATA SHEET

## ComfortStar®

| CIP12CD-L  |  |
|--|--|
| Location: _____<br>Engineer: _____<br>Submitted to: _____<br>Submitted by: _____<br>Reference: _____ | Approval: _____<br>Date: _____<br>Construction: _____<br>Unit #: _____<br>Drawing #: _____ |

|                    |                                     |
|--------------------|-------------------------------------|
| <b>Set Model</b>   | Indoor unit model      CIP12CD(I)-L |
| Outdoor unit model | CIP12CD(O)-L                        |
| <b>Certified</b>   | AHRI                                |

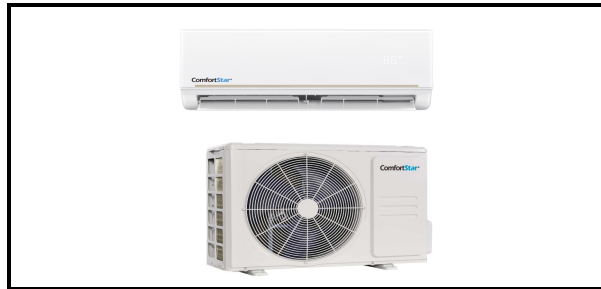

| SYSTEM PERFORMANCE DATA              |       |            |
|--------------------------------------|-------|------------|
| <b>Cooling (Standard conditions)</b> |       |            |
| Capacity                             | Btu/h | 11500      |
| Range                                | Btu/h | 3030~12500 |
| Input                                | W     | 957        |
| Range                                | W     | 80~900     |
| Current                              | A     | 4.16       |
| Range                                | A     | 0.8~6.5    |
| EER                                  | Btu/w | 12.00      |
| EER2                                 | Btu/w | 12.00      |
| SEER                                 | Btu/w | 21.50      |
| SEER2                                | Btu/w | 21.50      |
| Rated Power Input                    | HP    | 2.95       |
| Rated Current                        | A     | 13.5       |
| Starting current                     | A     | 0          |

| INDOOR UNIT DATA              |                 |                   |
|-------------------------------|-----------------|-------------------|
| Indoor fan motor              | Model           | ZKFP-13-8-4-17    |
|                               | Speed(Hi/Mi/Lo) | 1200/1040/960     |
| Indoor air flow (Hi/Mi/Lo)    |                 | 323.5/232.8/194.4 |
| Indoor noise level (Hi/Mi/Lo) |                 | 40.5/36.0/26.5    |
| <b>Indoor unit</b>            |                 |                   |
| Dimension(W*D*H)              | mm              | 802x200x295       |
|                               | inch            | 31.57x7.87x11.61  |
| Packing (W*D*H)               | mm              | 875x285x380       |
|                               | inch            | 34.45x11.22x14.96 |
| Net/Gross weight              | kg              | 8.0/10.4          |
|                               | lbs             | 17.64/22.93       |

| REFRIGERANT PIPE DATA        |                 |                             |
|------------------------------|-----------------|-----------------------------|
| <b>Compressor</b>            |                 |                             |
| Model                        |                 | KSK103D33UEZ3               |
| Type                         |                 | ROTARY                      |
| Brand                        |                 | GMCC                        |
| Capacity                     | W               | 2035/3255                   |
| Input                        | W               | 325/826                     |
| Rated current(RLA)           | A               | 2.40/5.65                   |
| Refrigerant oil/oil charge   | ml              | ESTER OIL VG74 310          |
| Refrigerant type             | oz              | R410A/22.22                 |
| Design pressure              | MPa             | ///                         |
| <b>Refrigerant piping</b>    |                 |                             |
| Liquid side/ Gas side        | mm(inch)        | 6.35mm(1/4in)/12.7mm(1/2in) |
| Max. refrigerant pipe length | m               | 25                          |
|                              | inch            | 984.25                      |
| Max. difference in level     | m               | 10                          |
|                              | inch            | 394.70                      |
| Application area             | ft <sup>2</sup> | 161.4584-236.8062           |

| OUTDOOR UNIT DATA        |       |                   |
|--------------------------|-------|-------------------|
| <b>Outdoor fan motor</b> |       |                   |
| Model                    |       | ZKFN-25-10-5L     |
| Speed                    | r/min | 850/600           |
| Outdoor air flow         | CFM   | 1061.40           |
| Outdoor noise level      | dB(A) | 53.5              |
| <b>Outdoor unit</b>      |       |                   |
| Dimension(W*D*H)         | mm    | 720x270x495       |
|                          | inch  | 28.35x10.63x19.49 |
| Packing (W*D*H)          | mm    | 835x300x540       |
|                          | inch  | 32.87x11.81x21.26 |
| Net/Gross weight         | kg    | 21.2/23.0         |
|                          | lbs   | 46.738/50.706     |

Indoor unit dimension

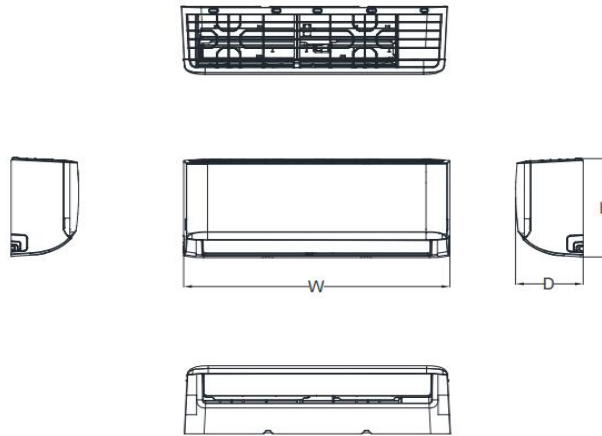

| Capacity | Body Code | W(mm/inch) | D(mm/inch) | H(mm/inch) |
|----------|-----------|------------|------------|------------|
| 6K~11K   | A         | 729/28.7   | 200/7.87   | 292/11.5   |
| 8K~14K   | B         | 802/31.57  | 200/7.87   | 295/11.61  |
| 12K~21K  | C         | 971/38.23  | 228/8.98   | 321/12.64  |
| 18K~28K  | D         | 1082/42.6  | 234/9.21   | 337/13.27  |
| 27K~36K  | F         | 1259/49.57 | 283/11.14  | 362/14.25  |

Outdoor unit dimension

