

# SUBMITTAL DATA SHEET

## ComfortStar®

<b>CIP12CA-HT</b>	
Location: _____ Engineer: _____ Submitted to: _____ Submitted by: _____ Reference: _____	Approval: _____ Date: _____ Construction: _____ Unit #: _____ Drawing #: _____

<b>Set Model</b>	
Indoor unit model	CIP12CA-HT(I)
Outdoor unit model	CIP12CA-HT(O)
<b>Certified</b>	
AHRI	
ETL	



SYSTEM PERFORMANCE DATA		
Power supply	V-Ph-Hz	115V~/60Hz/1P
Rated cooling capacity	Btu/h	11000(2050~12625)
Rated heating capacity	Btu/h	11500(2050~12625)
EER for cooling	Btu/W.h	8.5
EER2 (95F/35C) for cooling	Btu/W.h	8.4
SEER	Btu/W.h	16.0
SEER2 for cooling	Btu/W.h	17.0
COP for heating		3.0
	W/W	3.0
COP2 (47F/8.3C) for heating		3.0
HSPF Rating (Region IV)	Btu/W.h	9.7
HSPF2 Rating (Region IV)	Btu/W.h	8.0
Rated input	Cooling(W)	1310(200~1500)
	Heating(W)	1123(200~1600)
Rated current	Cooling(A)	11.8(2.0~13.0)
	Heating(A)	10.2(2.0~14.0)
Max Power input	Cooling(W)	1500
	Heating(W)	1600
Max Current	Cooling(A)	13.0
	Heating(A)	14
Moisture removal	Liters/h	1.3

INDOOR UNIT DATA		
Indoor air circulation(Cooling)	m3/h	500
	CFM	294.0
Indoor noise level at cooling	High dB(A)	38
	Med. dB(A)	34
	Low dB(A)	30
Indoor fan type		Cross flow
<b>Indoor fan speed H/M/L</b>		
Cooling	rpm	1250/1150/950/750/600
Heating	rpm	1250/1150//950/850/800
Dry	rpm	1250
Sleep	rpm	750
Indoor fan motor		22001-000238
Indoor fan motor output	W	20
Indoor net dimensions	mm	777×250×201
	Inch	30.59×4.72×7.91
Indoor net weight	kg	7.5
	Lbs.	16.5
Indoor packing dimensions	mm	840×315×260
	Inch	33.07×12.4×10.23
Indoor gross weight with pipe	kg	9.50
	Lbs.	20.90

REFRIGERANT PIPE DATA		
Refrigerant	oz	R410A/22.6
<b>Compressor</b>		
Type		Rotary
Model		KSK103D33UEZC3
Brand		GMCC
Evaporator		φ5×2
Condenser		φ7×1
<b>Connecting Pipe</b>		
Gas	Inch	3/8"
Liquid	Inch	1/4"
Connecting Wiring	Size×Core number	4×1.5mm2
Drainage Pipe		O.D 16mm
Control type		Remote
Suitable area	ft <sup>2</sup>	161~247
<b>Pressure</b>		
High(DP)	MPa	4.5
Low(SP)	MPa	1.9

OUTDOOR UNIT DATA		
Outdoor fan type		Propeller
Outdoor fan motor		22001-000493
Outdoor fan speed	rpm	1000
Outdoor fan motor output	W	33
Outdoor noise level	dB(A)	52
Outdoor net dimensions	mm	777×290×498
	(WxDxH )	Inch
Outdoor net weight	kg	23.5
	Lbs.	51.8
Outdoor packing dimensions	mm	838×338×540
	Inch	32.99×13.30×21.25
Outdoor gross weight with pipe	kg	26.5
	Lbs.	58.4

Indoor unit dimension

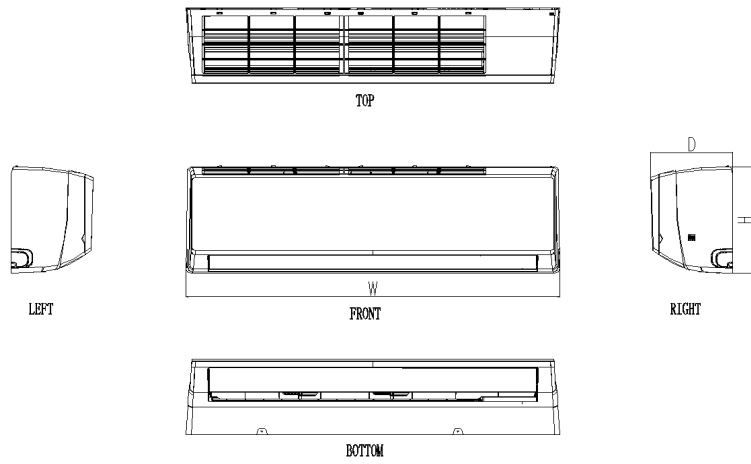

	W(mm)	H(mm)	D(mm)
12K	777	250	201
18K/24K	910	294	206

Outdoor unit dimension

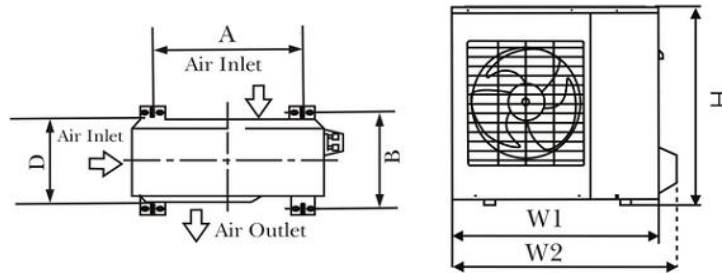

	H(mm)	W1(mm)	W2(mm)	D(mm)
12K	498	721	777	240
18K/24K	602	794	853	288