

Exploded View

Model

CWM5-18-15R

ComfortStar®

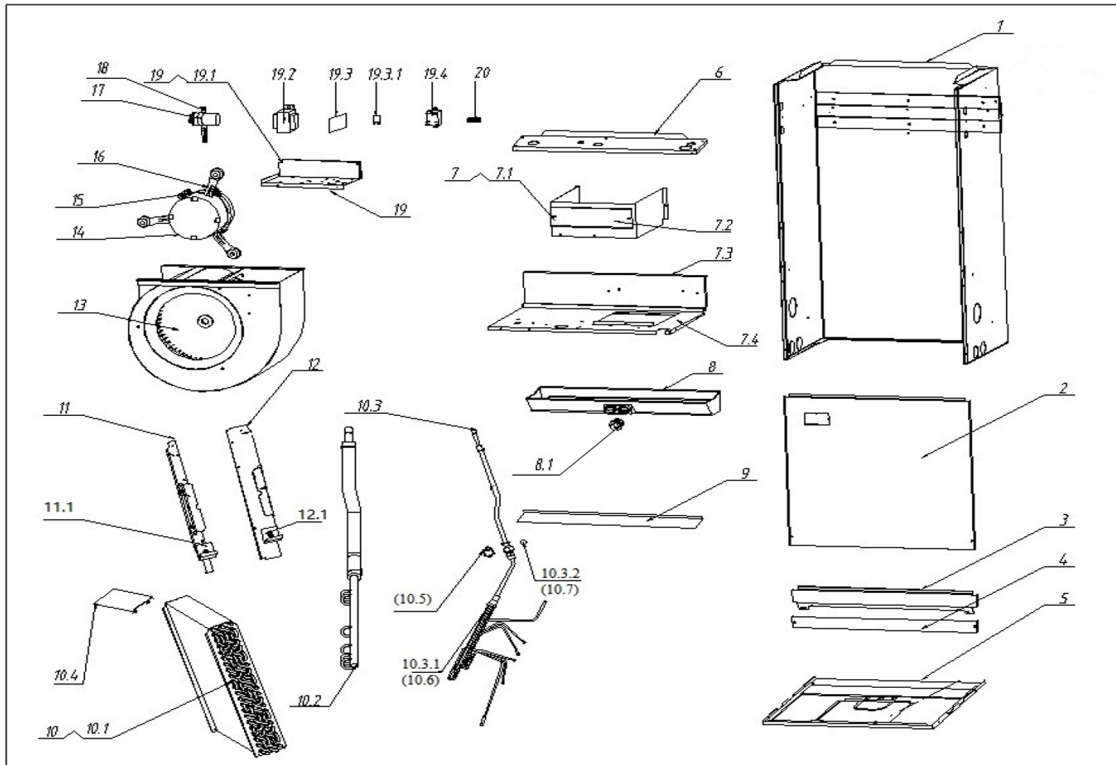

Optional functional parts

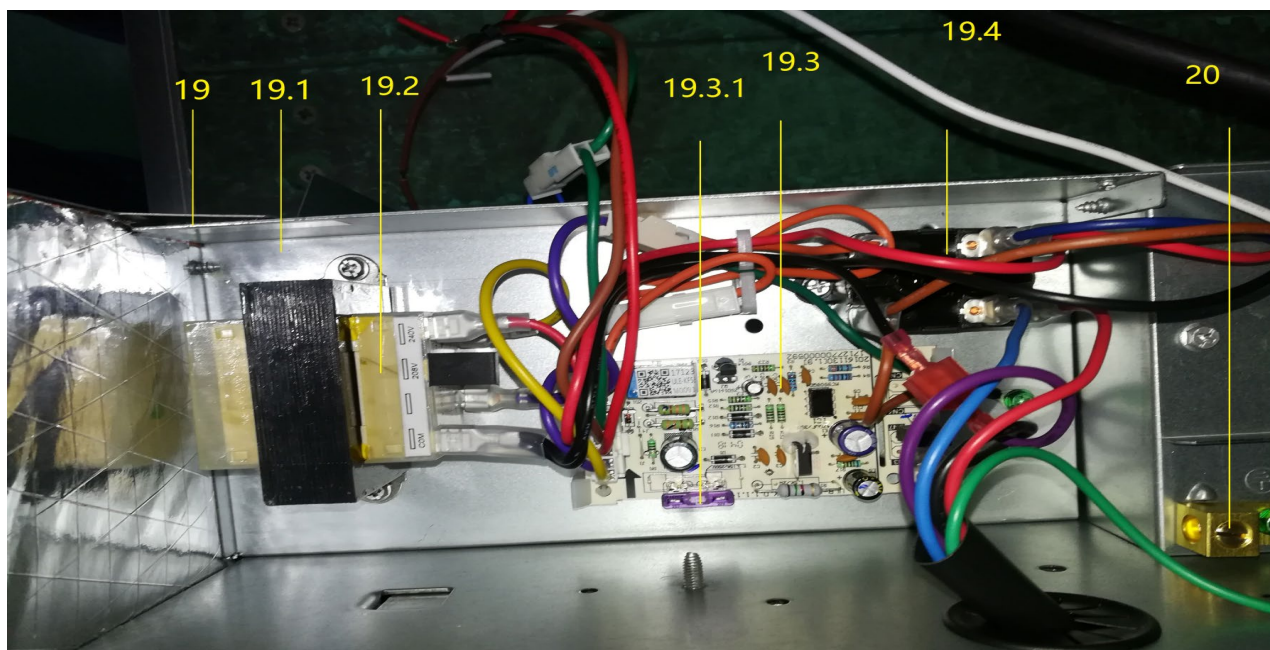



EX_ID	Spare Parts Code	Part Name(EN)	Qty.	Price	Remarks
1	12223000002377	Base assembly	1.00		
2	12223000010536	Side panel assembly	1.00		
3	12223000010529	Condenser connection board assembly	1.00		
4	12223000002181	In the interconnect board assembly	1.00		
5	12223000010533	Side panel assembly	1.00		
6	12223000002220	Components on the side	1.00		
7	12223000002126	Duct components	1.00		
7.1	12223000001960	Air duct damper	1.00		
7.2	12223000002111	Clapboard	1.00		
7.3	12223000001965	Duct under the baffle	1.00		
7.4	12223000002333	Wind wheel fixed plate	1.00		
8	12123000001080	Drainage pan assembly	1.00		
8.1	15500402000023	seal plug	1.00		
9	12223000002118	Drainage pan	1.00		
10	15823000004346	Evaporator assembly	1.00		
10.1	15823000004347	Evaporator	1.00		
10.2	15223000000125	Evaporator output pipe assembly	1.00		
10.4	12223000005759	Evaporator windshield plate ass'y	1.00		
10.6	15223000000127	Distributary ass'y	1.00		
10.7	12100901000010	Sealing ring	1.00		
11	12223000010535	Condenser connection board assembly	1.00		
11.1	12223000005760	Wind baffle of water collector	1.00		
12	12223000010527	Condenser connection board assembly	1.00		
12.1	12223000005760	Wind baffle of water collector	1.00		
13	12200101000021	Wind turbine parts	1.00		
14	11002012006945	Single Phase Asynchronous Motor	1.00		
15	12223000001992	Supporter Of Fan Motor	1.00		
16	12223000001934	Motor bracket ass'y I	3.00		
17	17400103000152	Capacitor	1.00		

18	12223000002177	Drainage pan clamp	1.00		
19	17223000007424	E-part box assembly	1.00		
19.1	12223000002176	Electrical Installation plate	1.00		
19.2	11203103000194	Linear Transformer	1.00		
19.3	17123000008117	Indoor unit main control board	1.00		
19.3.1	11203001001353	Fuse	1.00		
20	11201708000008	Wiring Terminal	1.00		