



Submittal

Split System Cooling

CWM5-24-15

Location: _____
Engineer: _____
Submitted to: _____
Submitted by: _____
Reference: _____

Approval: _____
Date: _____
Construction: _____
Unit # : _____
Drawing # : _____



Note: " Graphics in this document are for representation only. Actual model may differ in appearance."

Indoor unit dimension

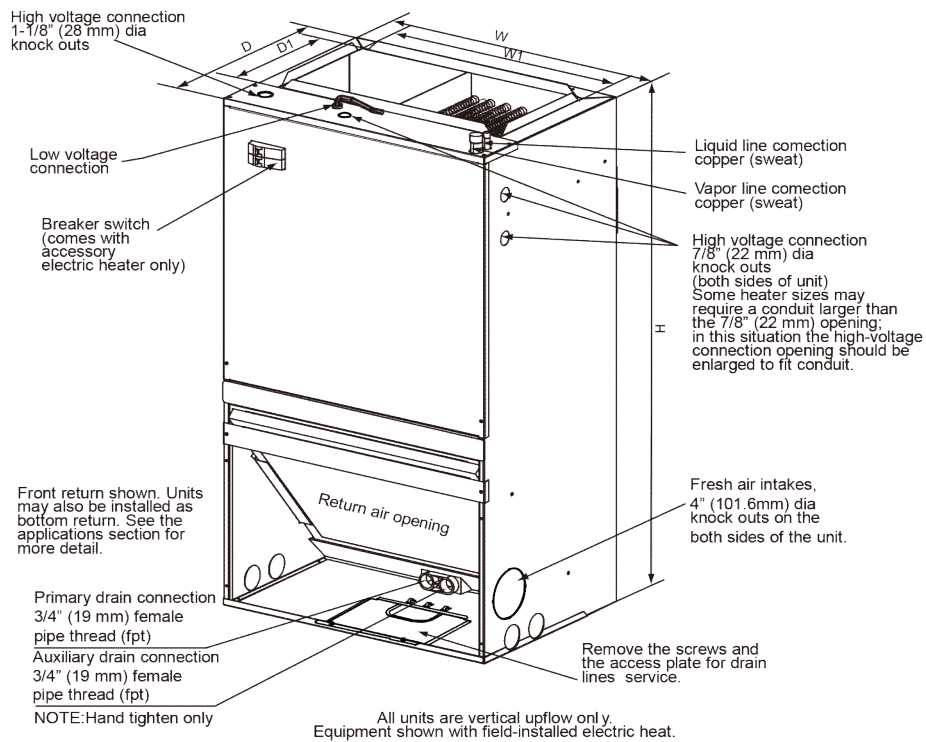

Model	Dimensions [IN.]					Unit Weight/Shipping Weight Lbs.
	Unit Height "H" IN.	Unit Width "W" IN.	Unit Width "W1" IN.	Unit Depth "D" IN.	Unit Depth "D1" IN.	
18K/24K	36-1/2	20-1/2	17-2/5	15	9-1/2	79/95
30K/36K	39-1/2	22	18-4/5	19	9-1/2	97/119

Specification

Indoor unit			CWM5-24-15
Power supply	Rated Voltage	V-Ph-Hz	208/230V,1Ph,60Hz
	Min. / Max. Voltage	V	187/253
Cooling	Capacity	Btu/h	24000
Min. Circuit Amps		A	2
Max. over current protection		A	15
Indoor fan motor	Type		ECM
	Horsepower (HP)		1/3
	Full Load Amps (FLA)	A	2
	Rated RPM		1050
Fan Blower	Material		Metal
	Type		Centrifugal
	Diameter	inch	10-3/4
	Height	inch	6
Indoor coil	Type		Tube & Fin
	Tube Material		Aluminum
	Tube Size	inch	9/32
Indoor air flow (Hi/Mi/Lo)		m3/h	1130/1380/1420
Indoor noise level (Hi/Mi/Lo)		dB(A)	54
Indoor unit	Dimension(W*D*H)	inch	20-1/2x15x36-1/2
	Packing (W*D*H)	inch	22-13/16x17-5/16x41-3/4
	Net/Gross weight	lbs	79/95
Refrigerant piping	Liquid side	inch	3/8
	Gas side	inch	3/4
Thermostat type			Remote Control
Operation temperature range	cooling	°F	55-115
	heating	°F	/

Outdoor Unit	Indoor Unit	Cooling Capacity	EER2	SEER2	Heating Capacity	HSPF2
MAH5-18-410	CWM5-24-15	18000	11.7	14.3	620	/
MAH5-24-410	CWM5-24-15	23200	11.2	13.4	710	/
MAH5-30-410	CWM5-24-15	27000	11.2	13.4	815	/
BAR5-18-15	CWM5-24-15	18000	11.7	14.3	620	/
BAR5-24-15	CWM5-24-15	23200	11.7	14.3	710	/
BAR5-30-15	CWM5-24-15	27200	11.7	14.3	815	/
BAH5-18-15	CWM5-24-15	18000	11.7	14.3	18000	7.5
BAH5-24-15	CWM5-24-15	23000	11.7	14.3	23000	7.5

Electric Heater Kits

NO.	Kit	Description	Ref. Air Handler Use
1	CHE2-05B	5kW Heat Strip	18/24/30/36
2	CHE2-08B	7.5kW Heat Strip	18/24/30/36
3	CHE2-10B	10kW Heat Strip	18/24/30/36
4	CHE2-15B	15kW Heat Strip, double Breaker panel	18/24/30/36
5	CHE2-20B	20kW Heat Strip, double Breaker panel	18/24/30/36

Electric Kit Mca/Mop Data

Heater Kit Model Used	Air Handler Model	Electric Heat (kW)	Min. Circuit Ampacity		Max. Fuse or Breaker (HACR) Ampacity		Fan speed (AC/HP)		
			240V	208V	240V	208V	Low	Medium	High
CHE2-05B	18	5	28.1	24.6	30	25	●	●	●
CHE2-08B		7.5	41.1	35.9	45	40	●	●	●
CHE2-10B		10	54.1	47.2	60	50	●	●	●
CHE2-05B	24	5	29	25.5	30	30	●	●	●
CHE2-08B		7.5	42	36.8	45	40	●	●	●
CHE2-10B		10	55	48.1	60	50	●	●	●
CHE2-05B	30	5	29.4	25.9	30	30	●	●	●
CHE2-08B		7.5	42.4	37.2	45	40	●	●	●
CHE2-10B		10	55.4	48.5	60	50	●	●	●
CHE2-15B		15	55.4/26.1	48.5/22.6	60/30	50/25	●	●	●
CHE2-05B	36	5	29.4	25.9	30	30	●	●	●
CHE2-08B		7.5	42.4	37.2	45	40	●	●	●
CHE2-10B		10	55.4	48.5	60	50	●	●	●
CHE2-15B		15	55.4/26.1	48.5/22.6	60/30	50/25	●	●	●
CHE2-20B		20	55.4/52.1	48.5/45.2	60/60	60/50	●	●	●

ComfortStar®

12201 N W 107th Avenue
Miami, FL 33178
1.866.524.9898 Toll Free
305.500.9898 Office
305.500.9896 Fax
<http://www.comfortstarusa.com>



The AHRI mark indicates Comfortstar participating in the AHRI Certification program. Visit ahridirectory.org for verification of individual certified products. Comfortstar reserves the right to change design and specs without notice. Comfortstar has a policy of update the data continuously. We are committed to using environmentally conscious print practices.

CWM5-24-15 21 Nov 2023
Supersedes CWM5-24-15 (Nov.2023)

© 2023 ComfortStar