



Submittal

Split System Cooling

CWM5-30-15R

Location: _____
Engineer: _____
Submitted to: _____
Submitted by: _____
Reference: _____

Approval: _____
Date: _____
Construction: _____
Unit # : _____
Drawing # : _____



Note:"

Graphics in this document are for representation only. Actual model may differ in appearance."

Indoor unit dimension

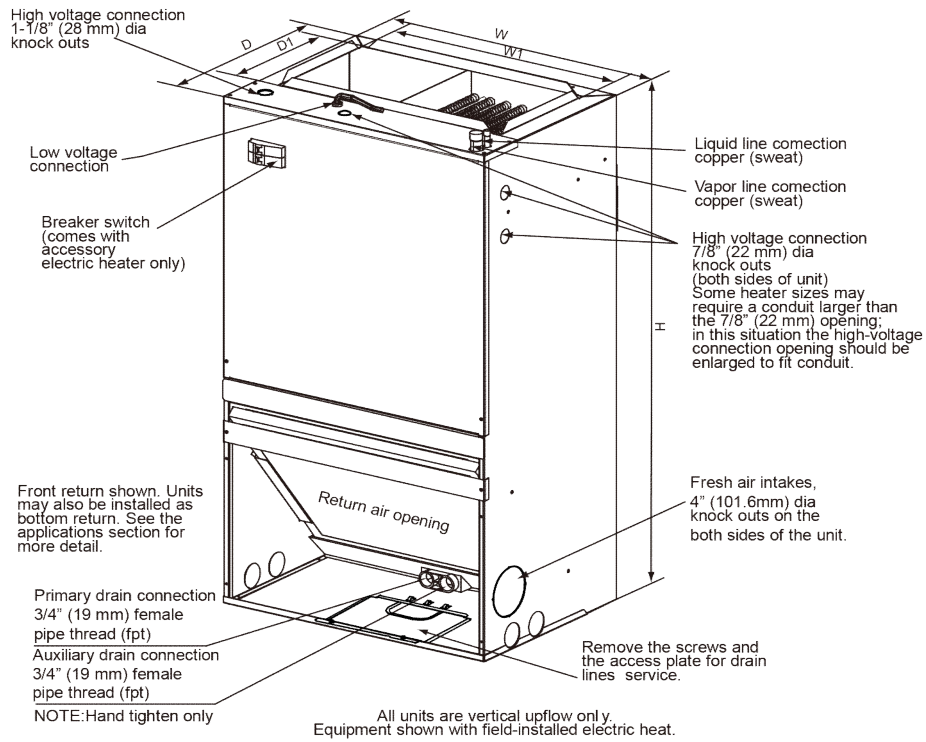

Model	Dimensions [IN.]					Unit Weight/Shipping Weight Lbs.
	Unit Height "H" IN.	Unit Width "W" IN.	Unit Width "W1" IN.	Unit Depth "D" IN.	Unit Depth "D1" IN.	
18K/24K	36-1/2	20-1/2	17-2/5	15	9-1/2	79/95
30K/36K	39-1/2	22	18-4/5	19	9-1/2	97/119



Specification

Model		CWM5-30-15R
NOMINAL RATING	Cooling(BTU/h) External Static	30000
	Pressure(in.w.c)	0.6
ELECTRICAL DATA	Voltage /Phase(60Hz)	208/230/1
	Min./Max.Voltage	187/253
	Min.Circuit Amps	1.6
	Max.Overcurrent Protection	15
FAN MOTOR	Motor Type	PSC
	Capacitor (uF)	15
	Horsepower (HP)	1/3
	Rated RPM	1075
	Full Load Amps (FLA)	1.28
FAN BLOWER	Material	Metal
	Type	Centrifugal
	Diameter(in.)	10-3/4
	Height(in.)	8
EVAPORATOR COIL	Type	Tube & Fin
	Tube Material	Aluminum
	Tube Size(in.)	9/32
Unit Dimensions(inch)	Height	39-1/2
	Width	22
	Depth	19
SOUND POWER (dB)		54
REFRIGERANT CONNECTION SIZE	Liquid Line Size (O.D.)	3/8
	Suction Line Size (O.D.)	3/4

Outdoor	Indoor	Cooling Capacity	EER2	SEER2	Heating Capacity	HSPF2
MAH5-30-410	CWM5-30-15R	27800	11.2	13.4	/	/
BAR5-24-15	CWM5-30-15R	24000	11.7	14.3	/	/
BAR5-36-15	CWM5-30-15R	35000	11.7	14.3	/	/
BAH5-24-15	CWM5-30-15R	23800	11.7	14.3	23800	7.5
BAH5-30-15	CWM5-30-15R	27200	11.7	14.3	27200	7.5
BAH5-36-15	CWM5-30-15R	34200	11.7	14.3	34200	7.5

Electric Heater Kits

NO.	Kit	Description	Ref. Air Handler Use
1	CHE2-05B	5kW Heat Strip	18/24/30/36
2	CHE2-08B	7.5kW Heat Strip	18/24/30/36
3	CHE2-10B	10kW Heat Strip	18/24/30/36
4	CHE2-15B	15kW Heat Strip, double Breaker panel	18/24/30/36
5	CHE2-20B	20kW Heat Strip, double Breaker panel	18/24/30/36

Electric Kit Mca/Mop Data

Heater Kit Model Used	Air Handler Model	Electric Heat (kW)	Min. Circuit Ampacity		Max. Fuse or Breaker (HACR) Ampacity		Fan speed (AC/HP)		
			240V	208V	240V	208V	Low	Medium	High
CHE2-05B	18	5	28.1	24.6	30	25	●	●	●
CHE2-08B		7.5	41.1	35.9	45	40	●	●	●
CHE2-10B		10	54.1	47.2	60	50	●	●	●
CHE2-05B	24	5	29	25.5	30	30	●	●	●
CHE2-08B		7.5	42	36.8	45	40	●	●	●
CHE2-10B		10	55	48.1	60	50	●	●	●
CHE2-05B	30	5	29.4	25.9	30	30	●	●	●
CHE2-08B		7.5	42.4	37.2	45	40	●	●	●
CHE2-10B		10	55.4	48.5	60	50	●	●	●
CHE2-15B		15	55.4/26.1	48.5/22.6	60/30	50/25	●	●	●
CHE2-05B	36	5	29.4	25.9	30	30	●	●	●
CHE2-08B		7.5	42.4	37.2	45	40	●	●	●
CHE2-10B		10	55.4	48.5	60	50	●	●	●
CHE2-15B		15	55.4/26.1	48.5/22.6	60/30	50/25	●	●	●
CHE2-20B		20	55.4/52.1	48.5/45.2	60/60	60/50	●	●	●

ComfortStar®

12201 N W 107th Avenue
Miami, FL 33178
1.866.524.9898 Toll Free
305.500.9898 Office
305.500.9896 Fax
<http://www.comfortstarusa.com>



The AHRI mark indicates Comfortstar participating in the AHRI Certification program. Visit ahridirectory.org for verification of individual certified products. Comfortstar reserves the right to change design and specs without notice. Comfortstar has a policy of update the data continuously. We are committed to using environmentally conscious print practices.

CWM5-30-15R 20 Nov 2023
Supersedes CWM5-30-15R (Nov.2023)

© 2023 ComfortStar