

Natural Gas to L.P. Gas Conversion Kit Instruction

Between 0 and 2,000 Feet Only

For United States/Canada Installations

For AFUE 80% Series Furnace And AFUE 81% Series Gas Package

IMPORTANT: Read all instructions before beginning the conversion of the appliance.

This conversion kit is for gas furnace installations to convert a natural gas furnace to a propane (LP) gas application. High altitude (above 2000ft (610m)) conversion refer to installation and user manual.

WARNING:

This conversion kit shall be installed by a qualified service agency in accordance with the manufacturer's instructions and all applicable codes and requirements of the authority having jurisdiction. If the information in these instructions is not followed exactly, a fire, an explosion or production of carbon monoxide may result causing property damage, personal injury or loss of life. The qualified service agency is responsible for the proper installation of this kit. The installation is not proper and complete until the operation of the converted appliance is checked as specified in the manufacturer's instructions supplied with the kit.

CAUTION:

All gas piping must conform with local building codes or, in the absence of local codes, Refer to the latest version of NFPA54/ANSI Z223.1 for US and the latest version of CSA B149.1 for Canada.. All electrical wiring must comply with the latest edition of the National Electrical Code ANSI/NFPA 70.

These instructions are primarily intended to assist qualified individuals experienced in the proper installation of this appliance. Some local codes require licensed installation/service personnel for this type of equipment.

CAUTION:

The gas supply shall be shut off prior to disconnecting the electrical power, before proceeding with the conversion.

To Turn Off the Fuel Supply to the Appliance:

1. Set the room thermostat to "OFF" or its lowest temperature setting.
2. Turn OFF the main gas supply to the appliance at the manual valve, outside of the appliance casing.
3. Remove the control access panel / louvered door.
4. Move the appliance gas valve lever/knob to the "OFF" position.
5. Turn OFF the electrical power to the appliance.

To Remove the Burner Assembly:

1. Follow the instructions "To Turn Off the Fuel Supply to the Appliance".
2. Disconnect the flame sensor wire from the burner box.
3. Disconnect the ignitor wires from the burner box.
4. Remove the wires from the terminals of the gas valve.
5. Remove supply gas piping from the gas valve.

To Remove the Burner Orifices:

1. Remove the four (4) fasteners that secure the gas manifold to the burner box, as shown in Figures 1. Carefully remove the gas manifold assembly from the burner box. Note that the gas manifold assembly consists of the gas valve, the gas manifold, and the orifices.
2. Carefully remove the burner orifices from the gas manifold, as shown in Figures 1.

CAUTION:

Caution: Do not re-drill the burner orifices. If the orifice size must be changed, use only new orifices.

Note: The size of the new orifices that will be installed into the unit will depend upon the type of conversion (sea level or high altitude; natural gas or LP gas). Please refer to the appropriate section for more details on your particular conversion.

To Convert the Unit to LP Gas For Altitudes Between 0 and 2,000 Feet Only

1. Table 1, Table 2 and Table 3 is a detailed listing of the components in the LP gas conversion kit. Please check the contents of the conversion kit with that of the parts listing, and familiarize yourself with each component.
2. Examine the rating plate of the unit to determine the rated input (Btu/hr). Count the number of burners in the burner box. Determine the appropriate LP gas orifice size for your conversion.
3. Install the appropriate LP gas burner orifices into the gas manifold. When installing the new orifices, DO NOT use pipe joint compound on the orifice threads. Screw the orifices into the manifold by hand until snug to eliminate cross threading, then tighten with a wrench. Before installing an orifice, check the face or side of the orifice for the drill number to ensure that it is the appropriate size.
4. For the conversion to LP gas from natural gas, the spring in the gas valve must be replaced. One gas valve conversion kit are supplied with this LP gas conversion kit is used to convert the White Rodgers Gas Valve. Then, install the appropriate spring using the instructions supplied with that kit.

Table 1: LP Gas Conversion Kit

For Furnace models:

220/50Hz: **90**/**110** 115/60Hz: **60**

Description	Part No.	Quantity
Installation Instructions	16127600001084	1
#55 LPG Main Burner Orifices	15527600000005	3/5/6
Conversion Kit for Gas Valve TLONG Gas Valve TGV654-216	TGV654-2	1
TLONG Gas Valve Valve Instruction	RQF-36J54-214.1-2	1
Reducer Bushings	RQF-36J22-214.1-1	1
Conversion Information Label	16000110001763	1

Table 2: LP Gas Conversion Kit

For Furnace models:220/50Hz: **135**
 115V/60Hz: **80**/**100**/120**

Description	Part No.	Quantity
Installation Instructions	16127600001084	1
#56 LPG Main Burner Orifices	15527600000007	5/6/7/8
Conversion Kit for Gas Valve TLONG Gas Valve TGV654-216	TGV654-2	1
TLONG Gas Valve Valve Instruction	RQF-36J54-214.1-2	1
Reducer Bushings	RQF-36J22-214.1-1	1
Conversion Information Label	16000110001763	1

Table 3: LP Gas Conversion Kit

For Furnace models:115V/60Hz: **40**

Description	Part No.	Quantity
Installation Instructions	16127600001084	1
#59 LPG Main Burner Orifices	15527600000372	5/6/7/8
Conversion Kit for Gas Valve TLONG Gas Valve TGV654-216	TGV654-2	1
TLONG Gas Valve Valve Instruction	RQF-36J54-214.1-2	1
Reducer Bushings	RQF-36J22-214.1-1	1
Conversion Information Label	16000110001763	1

Table 4: LP Gas Conversion Kit

For Gas Package models:
 71S060/**90S060**/**105S090**/**120S090**

Description	Part No.	Quantity
Installation Instructions	16127600000552	1
#59 LPG Main Burner Orifices	15527600000372	5/7
Conversion Kit for Gas Valve TLONG Gas Valve TGV654-216	TGV654-2	1
TLONG Gas Valve Valve Instruction	RQF-36J54-214.1-2	1
Reducer Bushings	RQF-36J22-214.1-1	1
Conversion Information Label	16000110001763	1

Table 5: LP Gas Conversion Kit

For Gas Package models:
 140S090/**160S090**/**160S110**

Description	Part No.	Quantity
Installation Instructions	16127600000552	1
#56 LPG Main Burner Orifices	15527600000007	6/7
Conversion Kit for Gas Valve TLONG Gas Valve TGV654-216	TGV654-2	1
TLONG Gas Valve Valve Instruction	RQF-36J54-214.1-2	1
Reducer Bushings	RQF-36J22-214.1-1	1
Conversion Information Label	16000110001763	1

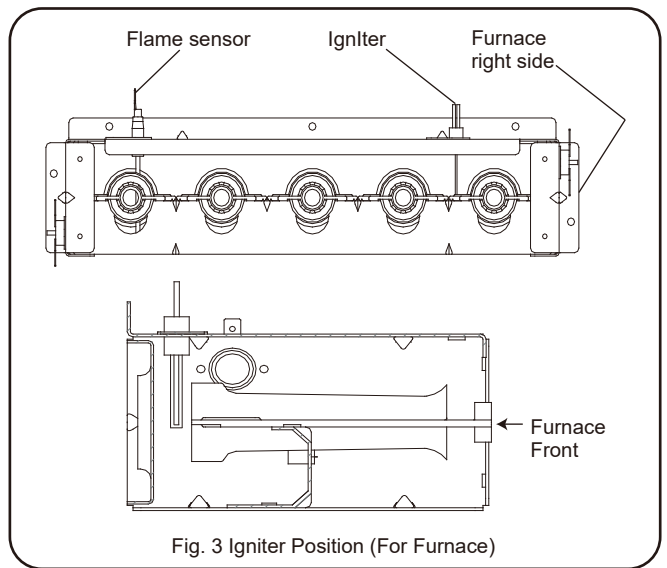
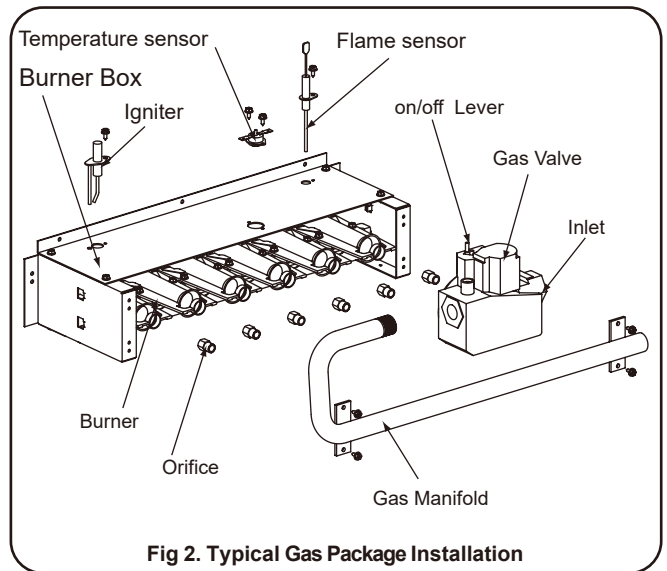
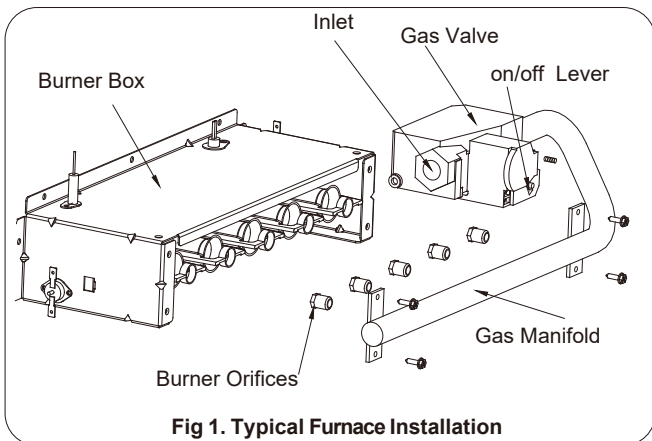

Reinstalling the Burner Assembly:

1. Reinstall the gas manifold assembly to the burner box with the four (4) fasteners, which were removed earlier.
2. After installing the burner, inspect the alignment of the burners with the heat exchanger tubes. The center of the burners should be aligned with the center of the tubes. The igniter and flame sensor position refer to Fig. 2 and Fig. 3
3. Reconnect the gas piping to the gas valve.
4. Reconnect the wires to the gas valve terminals.
5. Reconnect the igniter at the 2 position plug.
6. Reconnect the flame sensor wire.

Pressure Gauge Installation

NOTE: For natural gas installations, the incoming gas line pressure at the gas valve inlet must be between 5.0" WC and 10.5" WC. For LP gas installations, the incoming gas line pressure at the gas valve inlet must be between 11.0"WC and 13.0" WC. This pressure can be checked at the inlet end of the gas valve using a pressure gauge or U-tube manometer, which must be installed according to the manufacturer's supplied instructions.

LIGHTING AND ADJUSTMENT OF THE APPLIANCE

1. Turn ON the gas at the manual valve, outside of the unit.
2. Check all gas connections for leaks with a soap and water solution. If the solution bubbles there is a gas leak which must be corrected. Do NOT use an open flame to check for gas leaks.
3. Turn ON the electrical power to the appliance.
4. Move the gas valve lever/knob to the "ON" position. The lever/knob must be moved to the end of its range of motion to insure the valve is completely open. Use only your hand to push in or turn the gas control valve. Never use tools.
5. Set the room thermostat to a point above room temperature to begin the heating cycle of the unit.
6. Check that the unit ignites and operates properly. Refer to the installation instructions provided with your unit for the normal operating sequence.
7. After the flame ignites, visually inspect the burner assembly to ensure that the flame is drawn directly into the center of the heat exchanger tube, as shown in Figure 5. The end of the flame will be out of sight around the bend of the heat exchanger tube. In a properly adjusted burner assembly, the flame color should be blue with some light yellow streaks near the outer portions of the flame.

NOTE: Until all of the air is bled out of the gas line, the hot surface ignitor may not ignite the gas. If the ignition control locks out, turn the thermostat to its lowest setting and wait one minute then turn the thermostat to a point above room temperature and the ignitor will try again to ignite the main burners. This process may have to be repeated several times before the burners will ignite. Once the burners are lit, check all gas connections for leaks again with the soap and water solution. If the solution bubbles there is a gas leak which must be corrected. Do not use an open flame to check for gas leaks.

Checking the Manifold Pressure

The manifold pressure can be measured by installing a pressure gauge or U-tube manometer to the outlet end of the gas valve as follows:

1. With a 3/32 inch hex wrench, remove the manifold pressure tap plug located on the outlet side of the gas valve. Refer to Figure 4.
2. Install the pressure gauge or U-tube manometer according to the manufacturer's supplied instructions.
3. Set the room thermostat to a point above room temperature to start the furnace.
4. Allow the furnace to operate for three (3) minutes and then check the manifold pressure. For LP gas installations, the manifold pressure should be set to 10" WC. If the manifold pressure is not set to the appropriate pressure, then it must be adjusted.

Adjusting the Manifold Pressure

1. If the manifold pressure must be adjusted, then remove the protective cap from the top of the gas valve regulator, as shown in Figure 4.
2. Using a short screwdriver, turn the adjustment screw to obtain a reading of 10.0" WC for LP gas installations.

Note: Turning the screw clockwise increases the pressure, whereas, turning the screw counter-clockwise decreases the pressure.

3. Replace and tighten the protective cap over the adjustment screw.

Removing the Pressure Gauge or U-tube Manometer

Once the manifold pressure has been properly adjusted, the pressure gauge or U-tube manometer must be removed from the gas valve.

1. Turn the thermostat to its lowest setting.
2. Turn OFF all of the electrical power supplies to the unit.
3. Turn OFF the main gas supply to the unit at the manual shut-off valve, which is located outside of the unit.
4. Remove the manometer adapter from the gas valve and replace it with the 1/8" NPT manifold pressure plug that had been removed earlier. Ensure that the plug is tight and not cross-threaded.
5. Turn ON the electrical power to the unit.
6. Turn ON the main gas supply to the unit at the manual shut-off valve, which is located outside of the unit.

COMPLETING THE CONVERSION

1. For LP gas conversions, affix the conversion information label (#202082290011) near the rating plate on the inside of the control area. Finally, affix the gas valve conversion label found in the Gas Valve Conversion Kit on the gas valve. Each label should be prominent and visible, after installation.
2. Reinstall the appliance control panel/door.
3. Run the appliance through a complete cycle to assure proper operation.

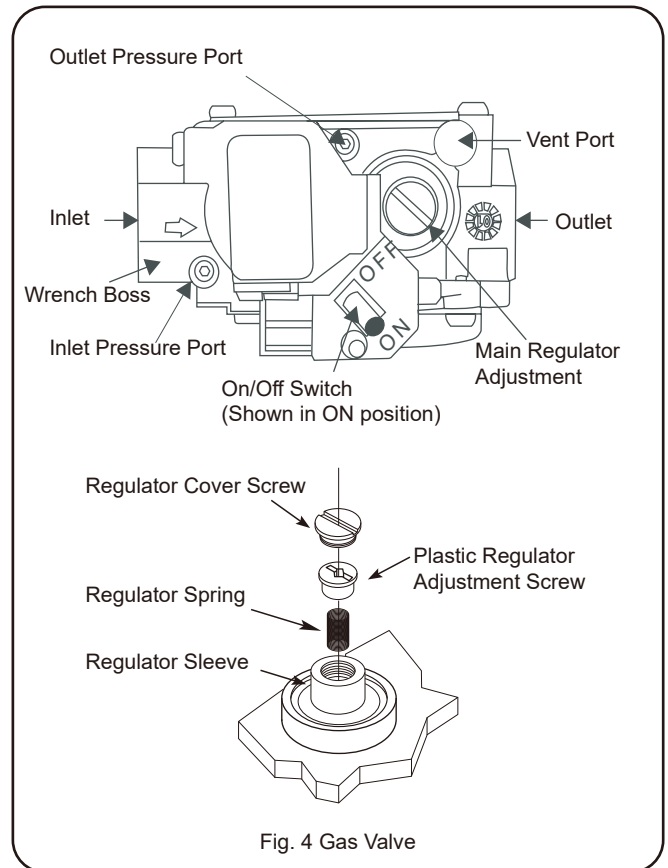

Fig. 4 Gas Valve

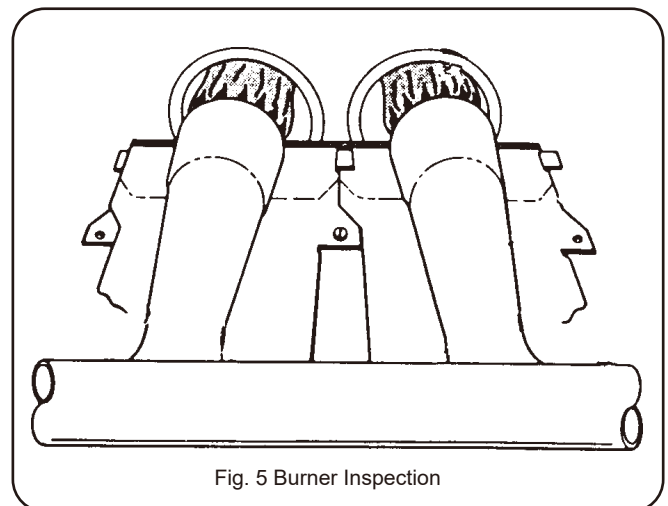

Fig. 5 Burner Inspection

