



SUBMITTAL DATA SHEET

ComfortStar®

CIP36CD-EL Location: _____ Engineer: _____ Submitted to: _____ Submitted by: _____ Reference: _____	Approval: _____ Date: _____ Construction: _____ Unit #: _____ Drawing #: _____
---	--

Set Model	
Indoor unit model	CIP36CD-EL(I)
Outdoor unit model	CIP36CD-EL(O)
Certified	AHRI  ETL 



SYSTEM PERFORMANCE DATA		
Rated Cooling(95°F /35C)		
Rated cooling capacity	Btu/h	36000.00
EER2 (95°F /35C)	Btu/W.h	9.00
SEER2	Btu/W.h	19.00
Rated Heating		
Rated Heating capacity	Btu/h	36000.00
HSPF2 Rating (Region IV)	Btu/W.h	8.50
HSPF2 Rating (Region V)	Btu/W.h	7.00
COP2 (47°F /8.3C)	W/W	3.01
Max. Heating capacity (5°F /-15°C)	Btu/h	21100.00
COP2 (5°F /-15°C)	W/W	1.75
Rated Input Consumption	Cooling	3850.00
	Heating	3500.00
Rated Current	Cooling	16.50
	Heating	15.20
Current Range	A	6~19.7
Max. Current (T1)	A	22.00
Min. Circuit Ampacity	A	23.00
Max. Fuse size	A	35.00

INDOOR UNIT DATA		
Indoor noise level		
Turbo/High/Med./Low/Mute	dB(A)	52/49/43/38/36
Indoor Motor		
Motor Brand		Broad-Ocean
Net dimensions (W x D x H)	mm	1192×360×260
	inch	46.93x14.17x10.23
Packing dimensions (W x D x H)	mm	1265×435×337
	inch	49.80x17.13x13.27
Net weight		
Indoor	kg/lbs	19.0/41.9
Indoor with all accessories	kg/lbs	20.5/45.2
Gross weight		
Indoor	kg/lbs	22.0/48.5
Indoor with all accessories	kg/lbs	23.5/51.8

REFRIGERANT PIPE DATA		
Compressor		
Brand		GMCC
Moisture removal	Liters/h	3.00
MXimum Operation Pressure	PSIG	550.00
Connecting Pipe		
Gas	inches	5/8"
Liquid	inches	1/4"
Connecting Wiring		4×16AWG
MXimum Line Length	(m/ft)	30 / 98
MXimum Height Difference Between Indoor and Outdoor	(m/ft)	20 / 65
Additional refrigerant charge	(g/m, oz/ft)	30 / 0.32
Operation temperature	°C	16~31
	°F	61~88
Ambinet temperature		
Indoor(cooling/ heating)	°C	>=17/<=30
Outdoor(cooling/heating)	°C	-15~50/-20~30
Indoor(cooling/ heating)	°F	>=62/<=86
Outdoor(cooling/heating)	°F	5~122/-4~86

OUTDOOR UNIT DATA		
Outdoor Motor		
Motor Brand		Broad-Ocean
Motor Type		DC
Outdoor noise level	dB(A)	63.00
Net dimensions (W x D x H)	mm	910x420x800
	inch	35.83x16.54x31.50
Outdoor Packing dimensions (W x D x H)(without pipe)	mm	1028×480×860
	inch	40.47x18.70x33.86
Net weight		
Outdoor	kg/lbs	51/112.5
Outdoor with 5m pipe	kg/lbs	53/116.8
Gross weight (without pipe)	kg/lbs	56/123.5
Gross weight (with 5m pipe)	kg/lbs	58.5/129

Indoor unit dimension

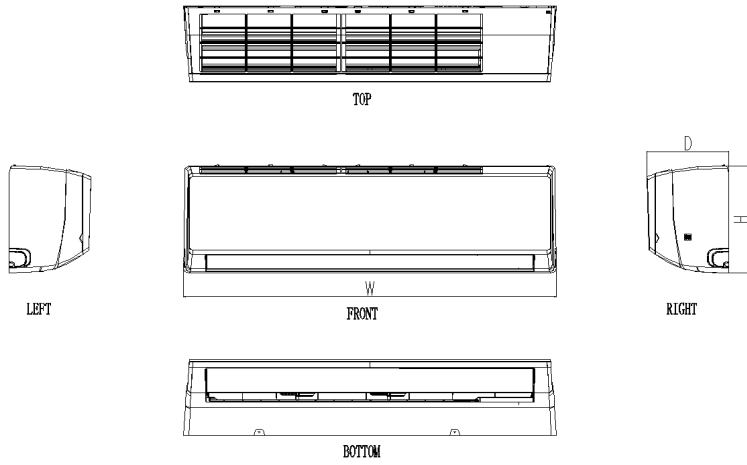

		12K(CA)	12K(CD)	18K(CD)	24K(CD)	36K(CD)
IDU	W	811mm	811mm	1010mm	1010mm	1192mm
	H	292mm	292mm	315mm	315mm	360mm
	D	205mm	205mm	220mm	220mm	260mm

Outdoor unit dimension

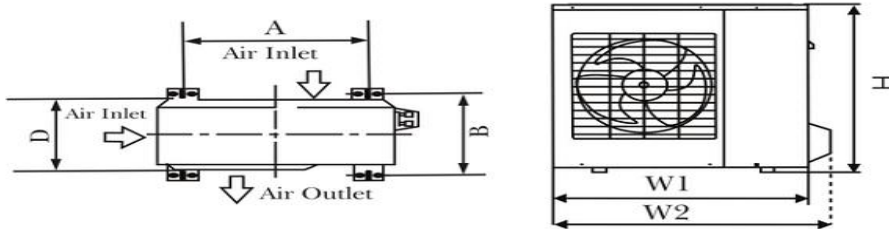

		12K(CA)	12K(CD)	18K(CD)	24K(CD)	36K(CD)
ODU	H	549mm	498mm	602mm	699mm	804mm
	W1	728mm	721mm	794mm	845mm	910mm
	W2	795mm	777mm	853mm	920mm	967mm
	D	256mm	240mm	288mm	329mm	355mm