

## Submittal

### Split System Cooling

AHU18-SG2

Location: \_\_\_\_\_  
Engineer: \_\_\_\_\_  
Submitted to: \_\_\_\_\_  
Submitted by: \_\_\_\_\_  
Reference: \_\_\_\_\_

Approval: \_\_\_\_\_  
Date: \_\_\_\_\_  
Construction: \_\_\_\_\_  
Unit # : \_\_\_\_\_  
Drawing # : \_\_\_\_\_



Note:" Graphics in this document are for representation only.Actual model may differ in appearance."

## Indoor unit installation size

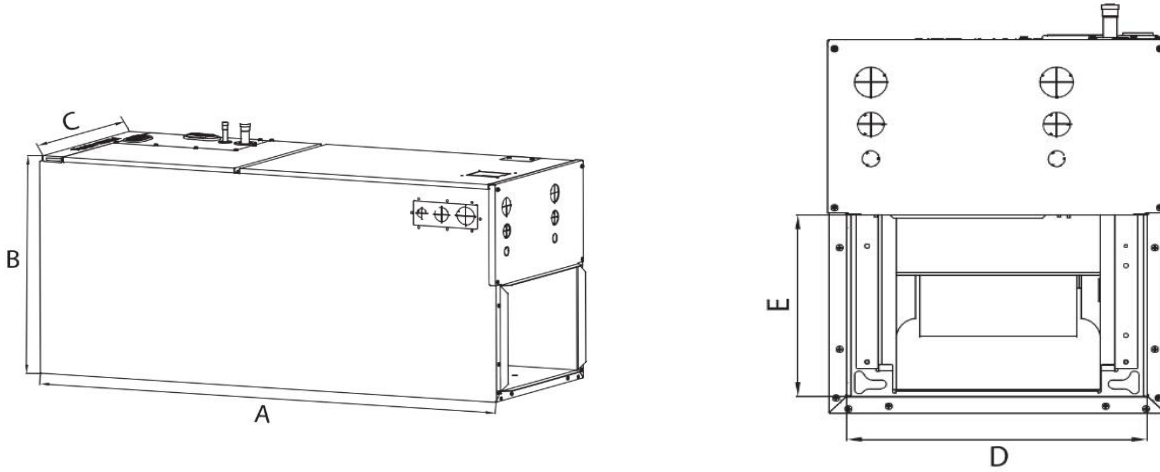

(unit:mm/inch)

Model		12K ~ 24K	30K ~ 48K	60K
Length of A	mm	1143	1245	1346
	inch	45	49	53
Length of B	mm	533	533	533
	inch	21	21	21
Length of C	mm	445	533	622
	inch	17-1/2	21	24-1/2
Length of D	mm	400	490	580
	inch	15-3/4	19-5/16	22-27/32
Length of E	mm	260	260	260
	inch	10-1/4	10-1/4	10-1/4

## Recommended size of filter

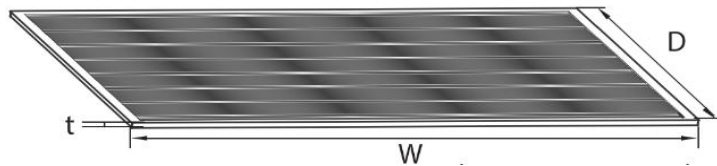

(unit:mm/inch)

Model (Btu/h)		12K ~24K	30K~36K	48K ~60K	
Recommended size of filter	W	mm	406.4	495.3	584.2
		inch	16	19-1/2	23
	D	mm	508	508	508
		inch	20	20	20
	t	mm	25.4	25.4	25.4
		inch	1	1	1

# Specification

AHU Model			AHU18-SG2
Power supply		V- Ph-Hz	208/230V,1Ph, 60Hz
MINIMUM CIRCUIT AMPACITY(Indoor)		A	3
MAX.FUSE(Indoor)		A	15
Indoor fan motor	Model		ZKFD-250-8-1
	RLA	A	1
Indoor air flow (Hi/Mi/Lo)		m3/h	980/900/830
Indoor air flow (Hi/Mi/Lo)		CFM	576.47/529.41/488.24
ESP	Range	Pa	0-200
	Range	ln. wg.	0-0.8
Indoor noise level (Hi/Mi/Lo)		dB(A)	36/34/32
Throttle type		/	EXV
Indoor unit	Dimension(W*D*H)	mm	445*534*1143
	Dimension(W*D*H)	inch	21*17-1/2*45
	Packing (W*D*H)	mm	640x530x1280
	Packing (W*D*H)	inch	25.20x20.87x50.39
	Net/Gross weight	Kg	48/58.7
	Net/Gross weight	lbs.	105.82/129.41

Outdoor Unit	Indoor Unit	Cooling Capacity	EER2	SEER2	HSPF	HSPF2
CPH18CD(O)	AHU18-SG2	18000(6880~21000)	12.4	18	11	9.3
CPR18CD(O)	AHU18-SG2	18000(5300~18700)	10.9	17.0	8.8	6.9

## Fan performance

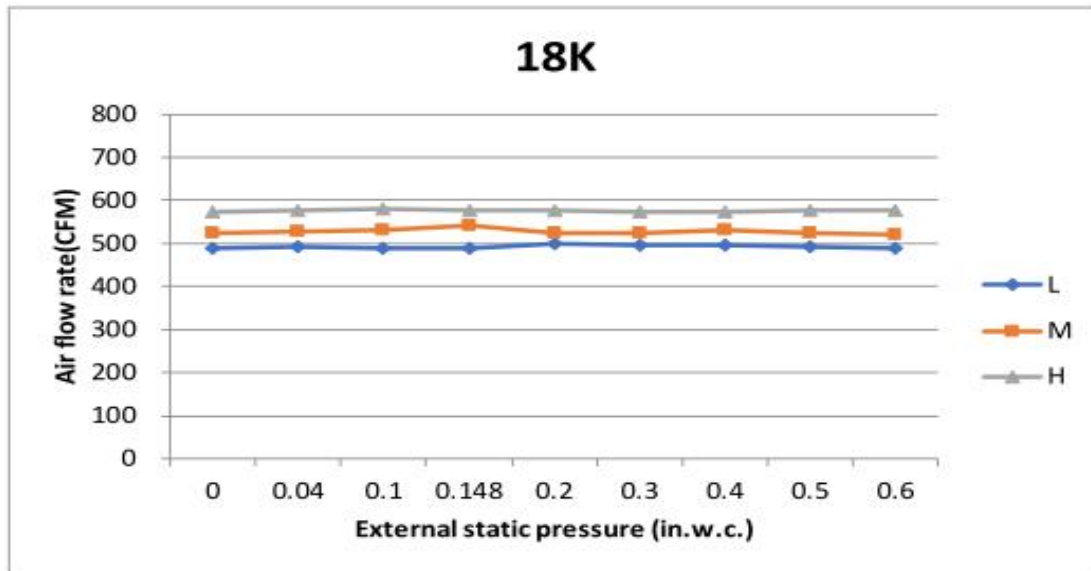

# ComfortStar®

12201 N W 107th Avenue  
Miami, FL 33178  
1.866.524.9898 Toll Free  
305.500.9898 Office  
305.500.9896 Fax  
<http://www.comfortstarusa.com>

---



The AHRI mark indicates Comfortstar participating in the AHRI Certification program. Visit [ahridirectory.org](http://ahridirectory.org) for verification of individual certified products. Comfortstar reserves the right to change design and specs without notice. Comfortstar has a policy of update the data continuously. We are committed to using environmentally conscious print practices.

AHU18-SG2 8th DEC. 2023  
Supersedes AHU18-SG2 (DEC.2023)

© 2023 ComfortStar