



# Submittal

## Split System Cooling

CWM4-18-15

Location: \_\_\_\_\_  
Engineer: \_\_\_\_\_  
Submitted to: \_\_\_\_\_  
Submitted by: \_\_\_\_\_  
Reference: \_\_\_\_\_

Approval: \_\_\_\_\_  
Date: \_\_\_\_\_  
Construction: \_\_\_\_\_  
Unit # : \_\_\_\_\_  
Drawing # : \_\_\_\_\_



Note:" *Graphics in this document are for representation only. Actual model may differ in appearance.*"

## Unit dimension

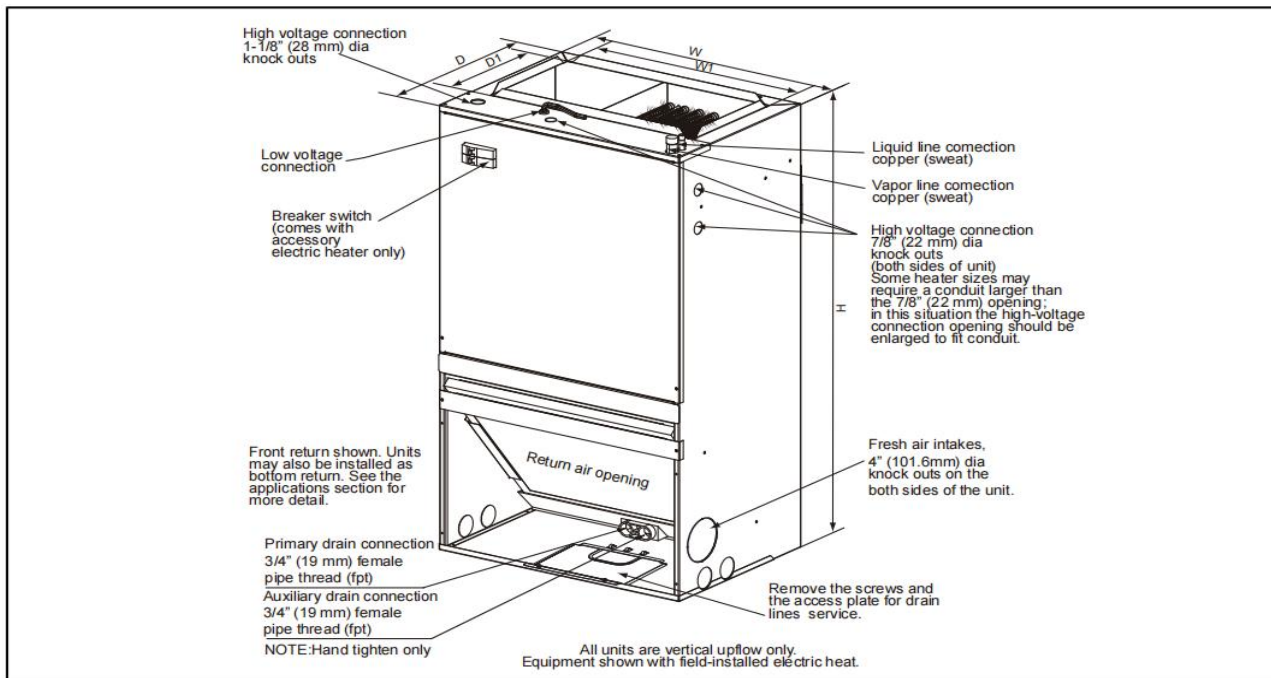

Model	Dimensions [IN.]					Unit Weight/Shipping Weight Lbs.
	Unit Height "H" IN.	Unit Width "W" IN.	Unit Width "W1" IN.	Unit Depth "D" IN.	Unit Depth "D1" IN.	
18K/24K	36-1/2	20-1/2	17-2/5	15	9-1/2	92/101
30K/36K	39-1/2	21-9/10	18-4/5	17-1/2	9-1/2	97/119

## Specification

Model		<b>CWM4-18-15</b>	
Indoor fan motor	Type		ECM
	Power supply		AC220-240V/50 60Hz
	Model		DZJ-249F-12
	Output	W	249
	rate current	A	2.6
	Speed	rpm	1050
Static pressure		Pa	75
Indoor air flow		CFM	620
Indoor noise level		dB(A)	48.5
Throttling type			Piston
Indoor coil	Evaporator type		Copper tube&Aluminum foil
	Number of row		5 rows 11u
	Tube pitch(a)xrow pitch(b)	in	0.83x0.53
	Fin spacing	in	1/17
	Evaporator dimension	in	17"x18-1/5"x2-3/5"
Indoor dimension	Unit dimension (W*D*H)	in	20-1/2"x15"x36-1/2"
		mm	520x381x927
		in	23-3/7"x17-1/2"x39-1/2"
		mm	600x450x1005
	Net / Gross weight	kg	37/41.5
		lbs	88/101

Condenser Model	AHU Model	Capacity	EER2	SEER	SEER2
BAH4-18-15	CWM4-18-15	18000.00	11.70	15	14.30
BAR4-18-15	CWM4-18-15	18000.00	11.70	15	14.30

### Heater Kit Accessories

Model	Description	18K	24K	30K	36K
CHE4-05B	5 kW heating kit, single-pole circuit breaker	•	•	•	•
CHE4-08B	7.5 kW heating kit, single-pole circuit breaker	•	•	•	•
CHE4-10B	10 kW heating kit, single/double pole circuit breaker	•	•	•	•

### MCA/MOP data of electric heat kit

Heat kit model	AHU model	(kW) electric heat	MIN. Circuit Ampacity		MAX. Fuse or Breaker (HACR) Ampacity		Fan speed				
			230 VAC	208 VAC	230 VAC	208 VAC	1	2	3	4	5
CHE4-05B	18K	5	22.68	19.66	25	25	•	•	•	•	•
CHE4-08B		7.5	34.04	29.50	40	35	×	×	•	•	•
CHE4-10B		10	45.37	39.32	55	45	×	×	•	•	•
CHE4-05B	24K	5	22.68	19.66	25	25	•	•	•	•	•
CHE4-08B		7.5	34.04	29.50	40	35	×	×	•	•	•
CHE4-10B		10	45.37	39.32	55	45	×	×	•	•	•
CHE4-05B	30K	5	22.68	19.66	25	25	•	•	•	•	•
CHE4-08B		7.5	34.04	29.50	40	35	×	•	•	•	•
CHE4-10B		10	45.37	39.32	55	45	×	×	•	•	•
CHE4-05B	36K	5	22.68	19.66	25	25	•	•	•	•	•
CHE4-08B		7.5	34.04	29.50	40	35	×	•	•	•	•
CHE4-10B		10	45.37	39.32	55	45	×	×	•	•	•

# ComfortStar®

12201 N W 107th Avenue  
Miami, FL 33178  
1.866.524.9898 Toll Free  
305.500.9898 Office  
305.500.9896 Fax  
<http://www.comfortstarusa.com>

---



The AHRI mark indicates Comfortstar participating in the AHRI Certification program. Visit [ahridirectory.org](http://ahridirectory.org) for verification of individual certified products. Comfortstar reserves the right to change design and specs without notice. Comfortstar has a policy of update the data continuously. We are committed to using environmentally conscious print practices.

CWM4-18-15 18th AUG. 2023  
Supersedes CWM4-18-15 (AUG.2023)

© 2023 ComfortStar