

# SUBMITTAL DATA SHEET

## ComfortStar®

### CARAT12CA-HP

Location: _____	Approval: _____
Engineer: _____	Date: _____
Submitted to: _____	Construction: _____
Submitted by: _____	Unit #: _____
Reference: _____	Drawing #: _____

**Set Model**

Indoor unit model            CARAT12CA(I)-HP  
 Outdoor unit model        CARAT12CA(O)-HP

**Certified**

AHRI 

UL 



### SYSTEM PERFORMANCE DATA

<b>Cooling (Standard conditions)</b>		
Power supply	V-Ph-Hz	115V,1Ph,60HZ
Capacity	Btu/h	12000
Range	Btu/h	3800~12100
Input	W	1165
Range	W	239~1890
Current	A	10.13
Range	A	2.07~16.5
EER	Btu/w	10.3
EER2	Btu/w	10.3
SEER	Btu/w	20.0
SEER2	Btu/w	20.8
<b>Heating (Standard conditions)</b>		
Capacity	Btu/h	12000
Range	Btu/h	2730~12500
Input	W	1154
Range	W	376~1390
Current	A	10.05
Range	A	3.26~16
COP	W/W	3.05
HSPF		11
HSPF2		8.7
Rated Power Input	W	1840
Rated Current	A	16.5

### REFRIGERANT PIPE DATA

<b>Compressor</b>		
Model		KSN98D64UFZ3
Type		ROTARY
Brand		GMCC
Capacity	W	1930/3100 ±3%
Input	W	292/765 ±3%
Rated current(RLA)	A	2.15/4.65 ±3%
Refrigerant oil/oil charge	ml	ESTER OIL VG74 300±10
<b>Refrigerant type</b>	kg	R410A/0.81
	oz	R410A/28.57
<b>Refrigerant piping</b>		
Liquid side/ Gas side	mm(inch)	6.35mm(1/4in)/12.7mm(1/2in)
Max. refrigerant pipe length	m	25
	inch	984.25
Max. difference in level	m	10
	inch	393.70
<b>Application area (Cooling Standard)</b>		
	m2	16~23
	ft2	172.22-247.57

### INDOOR UNIT DATA

<b>Indoor fan motor</b>		
Model		ZKFP-20-8-113
Input	W	35
Speed(Hi/Mi/Lo)	r/min	850/750/450
Indoor air flow (Hi/Mi/Lo)	m3/h	510/410/300
	CFM	300/241/177
Indoor noise level (Hi/Mi/Lo)	dB(A)	41/35/26.5
<b>Indoor unit dimension</b>		
Dimension(W*D*H)	mm	802x200x295
	inch	31.57x7.87x11.61
Packing (W*D*H)	mm	875x285x375
	inch	34.45x11.22x14.76
Net/Gross weight	kg	8.4/10.9
	lbs	18.52/24.03

### OUTDOOR UNIT DATA

<b>Outdoor fan motor</b>		
Model		ZKFN-34-10-1-3
Input	W	/
Speed	r/min	780/700/600
Outdoor air flow	m3/h	2100
	CFM	1235.8
Outdoor noise level	dB(A)	53.5
<b>Outdoor unit dimension</b>		
Dimension(W*D*H)	mm	765x303x555
	inch	30.12x11.93x21.85
Packing (W*D*H)	mm	885x375x605
	inch	34.84x14.76x23.82
Net/Gross weight	kg	28.2/32.2
	lbs	62.17/70.99

**Indoor unit dimension**

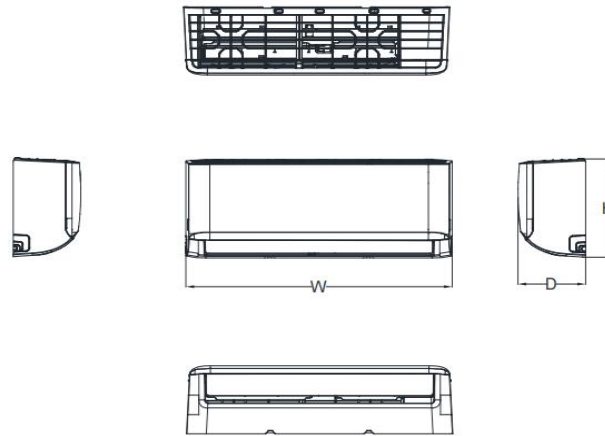

Capacity	Body Code	W(mm/inch)	D(mm/inch)	H(mm/inch)
6K~11K	A	729/28.7	200/7.87	292/11.5
8K~14K	B	802/31.57	200/7.87	295/11.61
12K~21K	C	971/38.23	228/8.98	321/12.64
18K~28K	D	1082/42.6	234/9.21	337/13.27
27K~36K	F	1259/49.57	283/11.14	362/14.25

**Outdoor unit dimension**

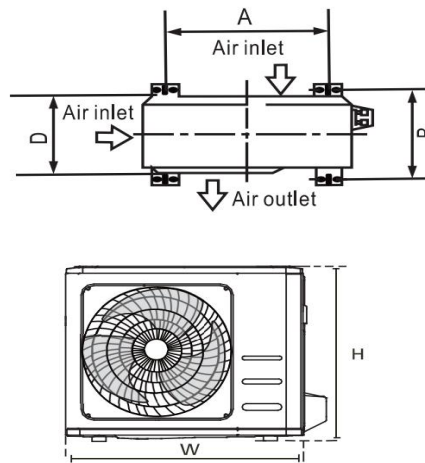

Outdoor Unit Dimensions (mm) W x H x D	Mounting Dimensions	
	Distance A (mm)	Distance B (mm)
681x434x285 (26.8"x17"x11.2")	460 (18.10")	292 (11.49")
700x550x270 (27.5"x21.6"x10.62")	450 (17.7")	260 (10.24")
700x550x275 (27.5"x21.6"x10.82")	450 (17.7")	260 (10.24")
720x495x270 (28.3"x19.5"x10.6")	452 (17.7")	255 (10.0")
728x555x300 (28.66"x21.85"x11.81")	452 (17.79")	302(11.89")
770x555x300 (30.3"x21.85"x11.81")	487 (19.2")	298 (11.73")
800x554x333 (31.5"x21.8"x13.1")	514 (20.24")	340 (13.39")
845x702x363 (33.25"x27.63"x14.29")	540 (21.26")	350 (13.8")
946x810x420 (37.21"x31.9"x16.53")	673 (26.5")	403 (15.87")