

SUBMITTAL DATA SHEET

ComfortStar®

CARAT12CD-HP

| | |
|--|--|
| Location: _____ Engineer: _____ Submitted to: _____ Submitted by: _____ Reference: _____ | Approval: _____ Date: _____ Construction: _____ Unit #: _____ Drawing #: _____ |
|--|--|

Set Model
 Indoor unit model CARAT12CD(I)-HP
 Outdoor unit model CARAT12CD(O)-HP

Certified

| | |
|------------------------|--|
| AHRI UL |   |
|------------------------|--|



SYSTEM PERFORMANCE DATA

| | | |
|--------------------------------------|---------|-------------------|
| Cooling (Standard conditions) | | |
| Power supply | V-Ph-Hz | 208/230V,1Ph,60HZ |
| Capacity | Btu/h | 12000 |
| Range | Btu/h | 3800~13350 |
| Input | W | 1111 |
| Range | W | 239~1528 |
| Current | A | 4.9 |
| Range | A | 1.05~6.78 |
| EER | Btu/w | 10.8 |
| EER2 | Btu/w | 10.8 |
| SEER | Btu/w | 20.5 |
| SEER2 | Btu/w | 21.4 |
| Heating (Standard conditions) | | |
| Capacity | Btu/h | 12000 |
| Range | Btu/h | 2730~13900 |
| Input | W | 1039 |
| Range | W | 376~1390 |
| Current | A | 4.6 |
| Range | A | 1.67~6.17 |
| COP | W/W | 3.38 |
| HSPF | | 11 |
| HSPF2 | | 9.2 |
| Rated Power Input | W | 2300 |
| Rated Current | A | 10.5 |

REFRIGERANT PIPE DATA

| | | |
|--|----------|-----------------------------|
| Compressor | | |
| Model | | KSN98D64UFZ3 |
| Type | | ROTARY |
| Brand | | GMCC |
| Capacity | W | 1930/3100 ±3% |
| Input | W | 292/765 ±3% |
| Rated current(RLA) | A | 2.15/4.65 ±3% |
| Refrigerant oil/oil charge | ml | ESTER OIL VG74 300±10 |
| Refrigerant type | kg | R410A/0.81 |
| | oz | R410A/28.57 |
| Refrigerant piping | | |
| Liquid side/ Gas side | mm(inch) | 6.35mm(1/4in)/12.7mm(1/2in) |
| Max. refrigerant pipe length | m | 25 |
| | inch | 985.25 |
| Max. difference in level | m | 10 |
| | inch | 393.70 |
| Application area (Cooling Standard) | | |
| | m2 | 16~23 |
| | ft2 | 172.22-247.57 |

INDOOR UNIT DATA

| | | |
|-------------------------------|-------|-------------------|
| Indoor fan motor | | |
| Model | | ZKFP-13-8-4 |
| Input | W | / |
| Speed(Hi/Mi/Lo) | r/min | 1250/1070/800 |
| Indoor air flow (Hi/Mi/Lo) | m3/h | 495/335/265 |
| | CFM | 291/197/156 |
| Indoor noise level (Hi/Mi/Lo) | dB(A) | 41/35/24 |
| Indoor unit dimension | | |
| Dimension(W*D*H) | mm | 802x200x295 |
| | inch | 31.57x7.87x11.61 |
| Packing (W*D*H) | mm | 875x285x375 |
| | inch | 34.45x11.22x14.76 |
| Net/Gross weight | kg | 8.5/10.9 |
| | lbs | 18.74/24.03 |

OUTDOOR UNIT DATA

| | | |
|-------------------------------|-------|-------------------|
| Outdoor fan motor | | |
| Model | | ZKFN-34-10-1-3 |
| Input | W | / |
| Speed | r/min | 780/700/600 |
| Outdoor air flow | m3/h | 2100 |
| | CFM | 1235.8 |
| Outdoor noise level | dB(A) | 53.5 |
| Outdoor unit dimension | | |
| Dimension(W*D*H) | mm | 765x303x555 |
| | inch | 30.12x11.93x21.85 |
| Packing (W*D*H) | mm | 885x375x605 |
| | inch | 34.84x14.76x23.82 |
| Net/Gross weight | kg | 26.9/30.9 |
| | lbs | 59.31/68.12 |

Indoor unit dimension

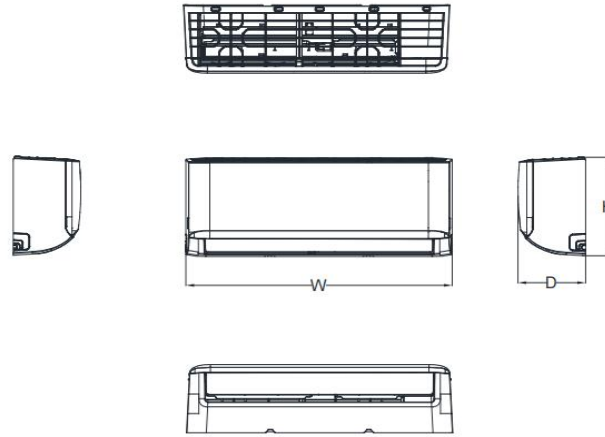

| Capacity | Body Code | W(mm/inch) | D(mm/inch) | H(mm/inch) |
|----------|-----------|------------|------------|------------|
| 6K~11K | A | 729/28.7 | 200/7.87 | 292/11.5 |
| 8K~14K | B | 802/31.57 | 200/7.87 | 295/11.61 |
| 12K~21K | C | 971/38.23 | 228/8.98 | 321/12.64 |
| 18K~28K | D | 1082/42.6 | 234/9.21 | 337/13.27 |
| 27K~36K | F | 1259/49.57 | 283/11.14 | 362/14.25 |

Outdoor unit dimension

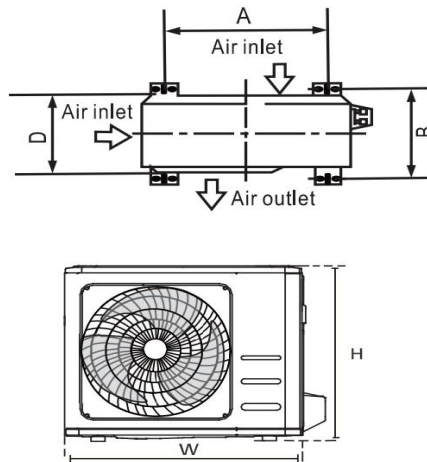

| Outdoor Unit Dimensions (mm) W x H x D | Mounting Dimensions | |
|---|---------------------|-----------------|
| | Distance A (mm) | Distance B (mm) |
| 681x434x285 (26.8"x17"x11.2") | 460 (18.10") | 292 (11.49") |
| 700x550x270 (27.5"x21.6"x10.62") | 450 (17.7") | 260 (10.24") |
| 700x550x275 (27.5"x21.6"x10.82") | 450 (17.7") | 260 (10.24") |
| 720x495x270 (28.3"x19.5"x10.6") | 452 (17.7") | 255 (10.0") |
| 728x555x300 (28.66"x21.85"x11.81") | 452 (17.79") | 302(11.89") |
| 770x555x300 (30.3"x21.85"x11.81") | 487 (19.2") | 298 (11.73") |
| 800x554x333 (31.5"x21.8"x13.1") | 514 (20.24") | 340 (13.39") |
| 845x702x363 (33.25"x27.63"x14.29") | 540 (21.26") | 350 (13.8") |
| 946x810x420 (37.21"x31.9"x16.53") | 673 (26.5") | 403 (15.87") |