

SUBMITTAL DATA SHEET

ComfortStar®

CARAT18CD-HP	
Location: _____ Engineer: _____ Submitted to: _____ Submitted by: _____ Reference: _____	Approval: _____ Date: _____ Construction: _____ Unit #: _____ Drawing #: _____

Set Model	
Indoor unit model	CARAT18CD(I)-HP
Outdoor unit model	CARAT18CD(O)-HP
Certified	
AHRI	
UL	



SYSTEM PERFORMANCE DATA		
Cooling (Standard conditions)		
Power supply	V-Ph-Hz	208/230V,1Ph,60HZ
Capacity	Btu/h	18000
Range	Btu/h	3900~20000
Input	W	1638
Range	W	180~1840
Current	A	7.5
Range	A	0.78~6.43
EER	Btu/w	11.0
EER2	Btu/w	11.0
SEER	Btu/w	19.5
SEER2	Btu/w	19.5
Heating (Standard conditions)		
Capacity	Btu/h	18800
Range	Btu/h	6300~19400
Input	W	1806
Range	W	375~1770
Current	A	/
Range	A	1.63~7.69
COP	W/W	3.05
HSPF		10
HSPF2		8.7
Rated Power Input	W	3250
Rated Current	A	14.0

INDOOR UNIT DATA		
Indoor fan motor		
Model		ZKFP-30-8-3-10
Input	W	36
Speed(Hi/Mi/Lo)	r/min	1200/1000/700
Indoor air flow (Hi/Mi/Lo)	m3/h	780/560/460
	CFM	459/329/270
Indoor noise level (Hi/Mi/Lo)	dB(A)	45/38/30.0
Indoor unit dimension		
Dimension(W*D*H)	mm	971x228x321
	inch	38.23x8.98x12.64
Packing (W*D*H)	mm	1045x305x405
	inch	41.14x12.01x15.94
Net/Gross weight	kg	11.1/14.5
	lbs	24.47/31.97

REFRIGERANT PIPE DATA		
Compressor		
Model		KSN140D21UFZ
Type		ROTARY
Brand		GMCC
Capacity	W	4385
Input	W	1140
Rated current(RLA)	A	7.50
Refrigerant oil/oil charge	ml	VG74 440
Refrigerant type		
	kg	R410A/1.35
	oz	R410A/47.62
Refrigerant piping		
Liquid side/ Gas side	mm(inch)	6.35mm(1/4in)/12.7mm(1/2in)
Max. refrigerant pipe length	m	30
	inch	1181.10
Max. difference in level	m	20
	inch	787.40
Application area (Cooling Standard)		
	m2	24~35
	ft2	258.33-376.74

OUTDOOR UNIT DATA		
Outdoor fan motor		
Model		ZKFN-34-10-1-3
Input	W	/
Speed	r/min	950/800/650/450
Outdoor air flow	m3/h	2100
	CFM	1235.8
Outdoor noise level	dB(A)	57
Outdoor unit dimension		
Dimension(W*D*H)	mm	805x330x554
	inch	31.69x12.99x21.81
Packing (W*D*H)	mm	940x410x605
	inch	37.01x16.14x23.82
Net/Gross weight	kg	33.5/37.7
	lbs	73.85/83.11

Indoor unit dimension

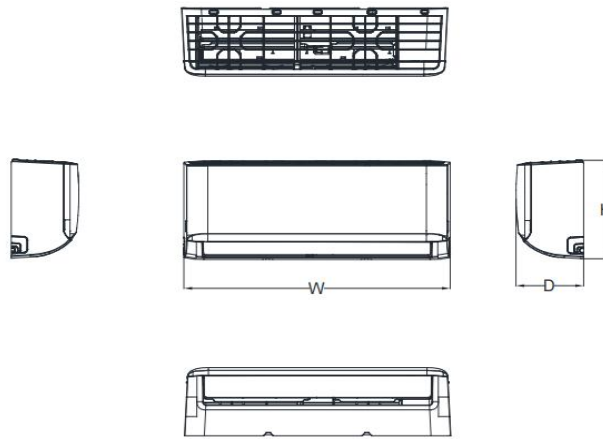

Capacity	Body Code	W(mm/inch)	D(mm/inch)	H(mm/inch)
6K~11K	A	729/28.7	200/7.87	292/11.5
8K~14K	B	802/31.57	200/7.87	295/11.61
12K~21K	C	971/38.23	228/8.98	321/12.64
18K~28K	D	1082/42.6	234/9.21	337/13.27
27K~36K	F	1259/49.57	283/11.14	362/14.25

Outdoor unit dimension

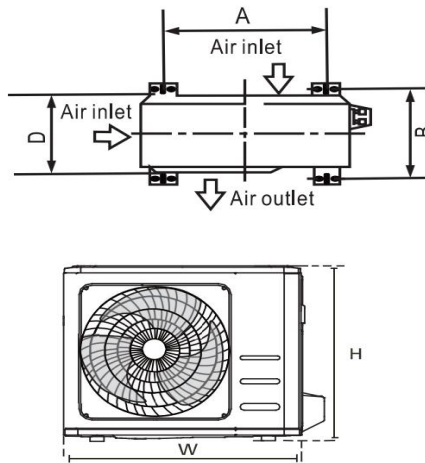

Outdoor Unit Dimensions (mm) W x H x D	Mounting Dimensions	
	Distance A (mm)	Distance B (mm)
681x434x285 (26.8"x17"x11.2")	460 (18.10")	292 (11.49")
700x550x270 (27.5"x21.6"x10.62")	450 (17.7")	260 (10.24")
700x550x275 (27.5"x21.6"x10.82")	450 (17.7")	260 (10.24")
720x495x270 (28.3"x19.5"x10.6")	452 (17.7")	255 (10.0")
728x555x300 (28.66"x21.85"x11.81")	452 (17.79")	302(11.89")
770x555x300 (30.3"x21.85"x11.81")	487 (19.2")	298 (11.73")
800x554x333 (31.5"x21.8"x13.1")	514 (20.24")	340 (13.39")
845x702x363 (33.25"x27.63"x14.29")	540 (21.26")	350 (13.8")
946x810x420 (37.21"x31.9"x16.53")	673 (26.5")	403 (15.87")