

# SUBMITTAL DATA SHEET

## ComfortStar®

<b>CARAT36CD-HP</b>	
Location: _____ Engineer: _____ Submitted to: _____ Submitted by: _____ Reference: _____	Approval: _____ Date: _____ Construction: _____ Unit #: _____ Drawing #: _____

**Set Model**  
 Indoor unit model            CARAT36CD(I)-HP  
 Outdoor unit model        CARAT36CD(O)-HP

**Certified**

AHRI	
UL	

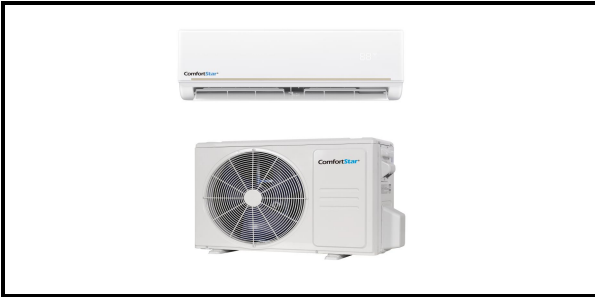

SYSTEM PERFORMANCE DATA		
<b>Cooling (Standard conditions)</b>		
Power supply	V-Ph-Hz	208/230V,1Ph,60HZ
Capacity	Btu/h	36000
Range	Btu/h	8300~37500
Input	W	3790
Range	W	340~3048
Current	A	16.8
Range	A	1.45~13.3
EER	Btu/w	9.5
EER2	Btu/w	9.5
SEER	Btu/w	18.0
SEER2	Btu/w	18.0
<b>Heating (Standard conditions)</b>		
Capacity	Btu/h	36000
Range	Btu/h	10900~37360
Input	W	3790
Range	W	610~3720
Current	A	16.8
Range	A	2.66~16.2
COP	W/W	2.78
HSPF		12
HSPF2		7.8
Rated Power Input	W	4800
Rated Current	A	21

INDOOR UNIT DATA		
<b>Indoor fan motor</b>		
Model		ZKFP-58-8-1-5
Input	W	58
Speed(Hi/Mi/Lo)	r/min	1200/960/600
Indoor air flow (Hi/Mi/Lo)	m3/h	1110/760/560
	CFM	652/447/329
Indoor noise level (Hi/Mi/Lo)	dB(A)	54/45/40
<b>Indoor unit dimension</b>		
Dimension(W*D*H)	mm	1259x283x362
	inch	49.60x11.14x14.25
Packing (W*D*H)	mm	1340x450x380
	inch	52.76x17.72x14.96
Net/Gross weight	kg	19.4/25.1
	lbs	42.77/55.34

REFRIGERANT PIPE DATA		
<b>Compressor</b>		
Model		KTF250D22UMT
Type		ROTARY
Brand		GMCC
Capacity	W	8095
Input	W	2200
Rated current(RLA)	A	10
Refrigerant oil/oil charge	ml	VG74/670
<b>Refrigerant type</b>		
	kg	R410A/3.40
	oz	R410A/119.93
<b>Refrigerant piping</b>		
Liquid side/ Gas side	mm(inch)	9.52mm(3/8in)/15.9mm(5/8in)
Max. refrigerant pipe length	m	65
	inch	2559.05
Max. difference in level	m	30
	inch	1181.10
<b>Application area (Cooling Standard)</b>		
	m2	48~70
	ft2	516.67-753.47

OUTDOOR UNIT DATA		
<b>Outdoor fan motor</b>		
Model		ZKFN-120-8-2
Input	W	150
Speed	r/min	1150/1050/900/850
Outdoor air flow	m3/h	3800
	CFM	2239.5
Outdoor noise level	dB(A)	65
<b>Outdoor unit dimension</b>		
Dimension(W*D*H)	mm	946x410x810
	inch	37.24x16.14x31.89
Packing (W*D*H)	mm	1090x500x875
	inch	42.91x19.69x34.45
Net/Gross weight	kg	68.1/73.8
	lbs	150.13/162.7

**Indoor unit dimension**

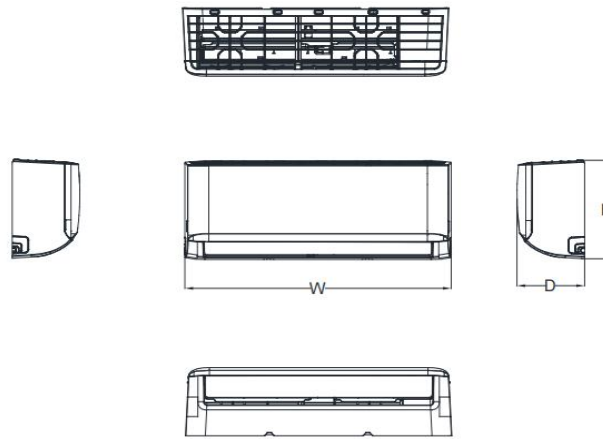

Capacity	Body Code	W(mm/inch)	D(mm/inch)	H(mm/inch)
6K~11K	A	729/28.7	200/7.87	292/11.5
8K~14K	B	802/31.57	200/7.87	295/11.61
12K~21K	C	971/38.23	228/8.98	321/12.64
18K~28K	D	1082/42.6	234/9.21	337/13.27
27K~36K	F	1259/49.57	283/11.14	362/14.25

**Outdoor unit dimension**

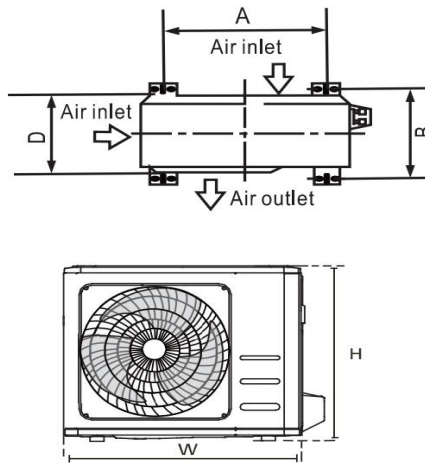

Outdoor Unit Dimensions (mm) W x H x D	Mounting Dimensions	
	Distance A (mm)	Distance B (mm)
681x434x285 (26.8"x17"x11.2")	460 (18.10")	292 (11.49")
700x550x270 (27.5"x21.6"x10.62")	450 (17.7")	260 (10.24")
700x550x275 (27.5"x21.6"x10.82")	450 (17.7")	260 (10.24")
720x495x270 (28.3"x19.5"x10.6")	452 (17.7")	255 (10.0")
728x555x300 (28.66"x21.85"x11.81")	452 (17.79")	302(11.89")
770x555x300 (30.3"x21.85"x11.81")	487 (19.2")	298 (11.73")
800x554x333 (31.5"x21.8"x13.1")	514 (20.24")	340 (13.39")
845x702x363 (33.25"x27.63"x14.29")	540 (21.26")	350 (13.8")
946x810x420 (37.21"x31.9"x16.53")	673 (26.5")	403 (15.87")