



SUBMITTAL DATA SHEET

ComfortStar®

CT32-12CA	
Location: _____ Engineer: _____ Submitted to: _____ Submitted by: _____ Reference: _____	Approval: _____ Date: _____ Construction: _____ Unit #: _____ Drawing #: _____

Set Model	
Indoor unit model	CT32-12CA (I)
Outdoor unit model	CT32-12CA (O)
Certified	
AHRI	
ETL	



SYSTEM PERFORMANCE DATA		
Power supply	V-Ph-Hz	115V-1Ph-60HZ
Cooling		
Capacity	Btu/h	12000
Input	W	1270
Current	A	13.0
SEER	Btu/h/W	17.00
EER	W/W	2.77
Rated Power Input	W	1800
Rated Current	A	17.0

INDOOR UNIT DATA		
Indoor fan motor		
Model		YKFG-15-4-28-1
Input	W	46
Capacitor	uF	3
Speed(Hi/Mi/Lo)	r/min	1180/950/750
Indoor air flow (Hi/Mi/Lo)	CFM	349/268/198
Indoor noise level (Hi/Mi/Lo)	dB(A)	41.0/35.0/26.5
Indoor unit		
Dimension(W*D*H)	mm	805x194x285
	inches	31.7x7.6x11.2
Packing (W*D*H)	mm	870x270x365
	inches	34.3x10.6x14.4
Net/Gross weight	kg	7.7/10.0
	lbs	17.0/22.1

REFRIGERANT PIPE DATA		
Compressor		
Model		KSK103D32UEZ31
Type		ROTARY
Brand		GMCC
Capacity	W	/
Input	W	/
Rated current(RLA)	A	/
Refrigerant oil/oil charge	ml	/
Refrigerant type	kg	R32/0.4
	oz	14.12
Design pressure	MPa	4.3/1.7
Refrigerant piping		
Liquid side/ Gas side	mm(inch)	6.35mm(1/4in)/12.7mm(1/2in)
Max. refrigerant pipe length	m	25
	inches	984.30
Max. difference in level	m	10
	inches	393.70
Operation temperature	°F	63~86
Indoor temperature	°F	63~90//
Outdoor temperature	°F	34~122//

OUTDOOR UNIT DATA		
Outdoor fan motor		
Model		ZKFN-25-10-5L
Speed	r/min	850/600
Outdoor air flow	CFM	1060.00
Outdoor noise level	dB(A)	54.0
Outdoor unit		
Dimension(W*D*H)	mm	720x270x495
	inches	28.3x10.6x19.5
Packing (W*D*H)	mm	835x300x540
	inches	32.9x11.8x21.3
Net/Gross weight	kg	21.5/22.4
	lbs	47.4/49.4

Indoor unit dimension

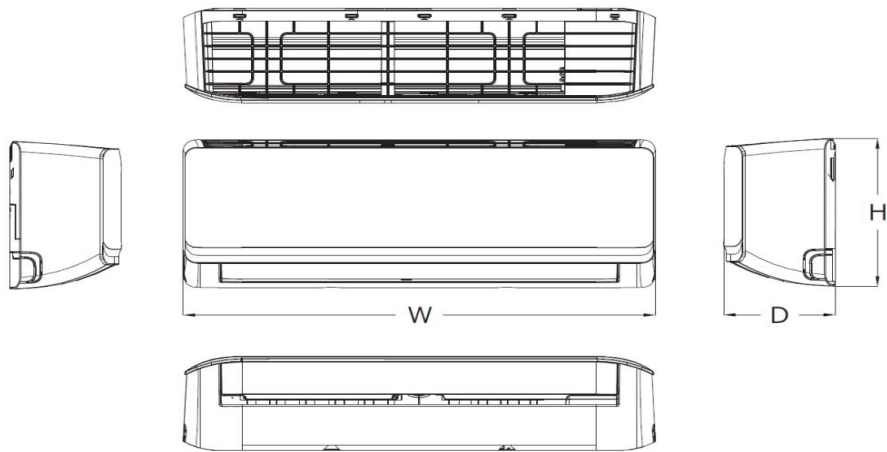

(The figure is for reference only)

Dimension(inch)	W	D	H
CT32-12CA (I)	31.7	7.6	11.2
CT32-12CD (I)	31.7	7.6	11.2
CT32-18CD (I)	37.7	8.4	11.9
CT32-24CD (I)	40.9	8.7	12.9

Outdoor unit dimension

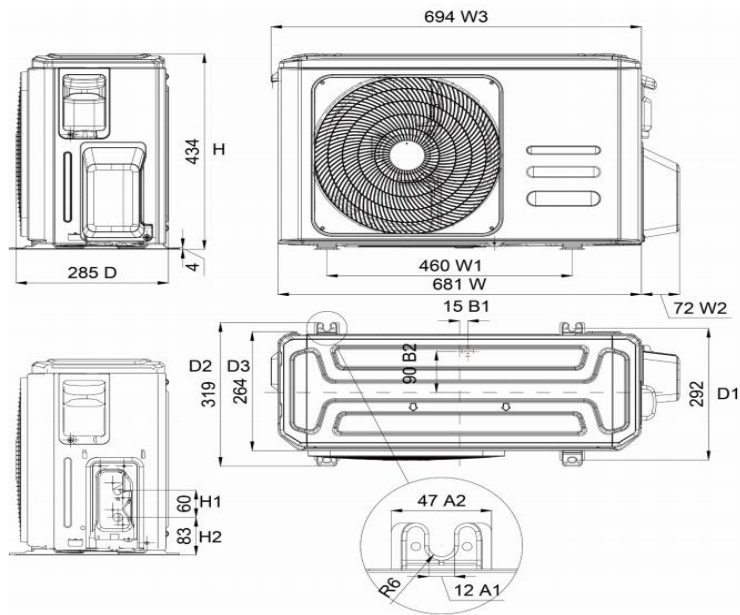

(The figure is for reference only)

Dimension(inch)	W	D	H
CT32-12CA (O)	28.3	10.6	19.5
CT32-12CD (O)	28.3	10.6	19.5
CT32-18CD (O)	30.1	11.9	21.9
CT32-24CD (O)	31.7	13.0	21.8