

SUBMITTAL DATA SHEET



CT32-12CD	
Location: _____ Engineer: _____ Submitted to: _____ Submitted by: _____ Reference: _____	Approval: _____ Date: _____ Construction: _____ Unit #: _____ Drawing #: _____

Set Model	
Indoor unit model	CT32-12CD (I)
Outdoor unit model	CT32-12CD (O)
Certified	
AHRI	
ETL	



SYSTEM PERFORMANCE DATA		
Power supply	V-Ph-Hz	115V-1Ph-60HZ
Cooling		
Capacity	Btu/h	12000
Input	W	1150
Current	A	7.6
SEER	Btu/h/W	17.00
EER	W/W	3.06
Rated Power Input	W	2000
Rated Current	A	13.0

INDOOR UNIT DATA		
Indoor fan motor		
Model		YKFG-20-4-10L
Input	W	47.4
Capacitor	uF	3
Speed(Hi/Mi/Lo)	r/min	1180/950/750
Indoor air flow (Hi/Mi/Lo)	CFM	349/268/198
Indoor noise level (Hi/Mi/Lo)	dB(A)	41.0/34.5/29.0
Indoor unit		
Dimension(W*D*H)	mm	805x194x285
	inches	31.7x7.6x11.2
Packing (W*D*H)	mm	870x270x365
	inches	34.3x10.6x14.4
Net/Gross weight	kg	7.7/9.9
	lbs	17.0/21.8

REFRIGERANT PIPE DATA		
Compressor		
Model		KSK103D32UEZ31
Type		ROTARY
Brand		GMCC
Capacity	W	2020/3245 ±3%
Input	W	332/850 ±3%
Rated current(RLA)	A	2.42/5.70 ±3%
Refrigerant oil/oil charge	ml	ESTER OIL VG74 280 ±10
Refrigerant type	kg	R32/0.4
	oz	14.12
Design pressure	MPa	4.3/1.7
Refrigerant piping		
Liquid side/ Gas side	mm(inch)	6.35mm(1/4in)/12.7mm(1/2in)
Max. refrigerant pipe length	m	25
	inches	984.30
Max. difference in level	m	10
	inches	393.70
Operation temperature	°F	63-86
Indoor temperature	°F	63-90//
Outdoor temperature	°F	34-122//

OUTDOOR UNIT DATA		
Outdoor fan motor		
Model		ZKFN-25-10-5L
Speed	r/min	850/600
Outdoor air flow	CFM	1060.00
Outdoor noise level	dB(A)	55.0
Outdoor unit		
Dimension(W*D*H)	mm	720x270x495
	inches	28.3x10.6x19.5
Packing (W*D*H)	mm	835x300x540
	inches	32.9x11.8x21.3
Net/Gross weight	kg	19.0/20.8
	lbs	41.9/45.9

Indoor unit dimension

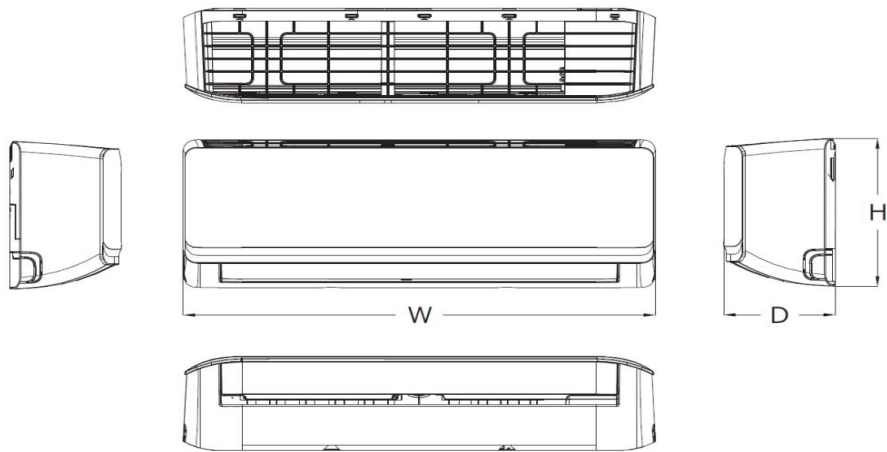

(The figure is for reference only)

Dimension(inch)	W	D	H
CT32-12CA (I)	31.7	7.6	11.2
CT32-12CD (I)	31.7	7.6	11.2
CT32-18CD (I)	37.7	8.4	11.9
CT32-24CD (I)	40.9	8.7	12.9

Outdoor unit dimension

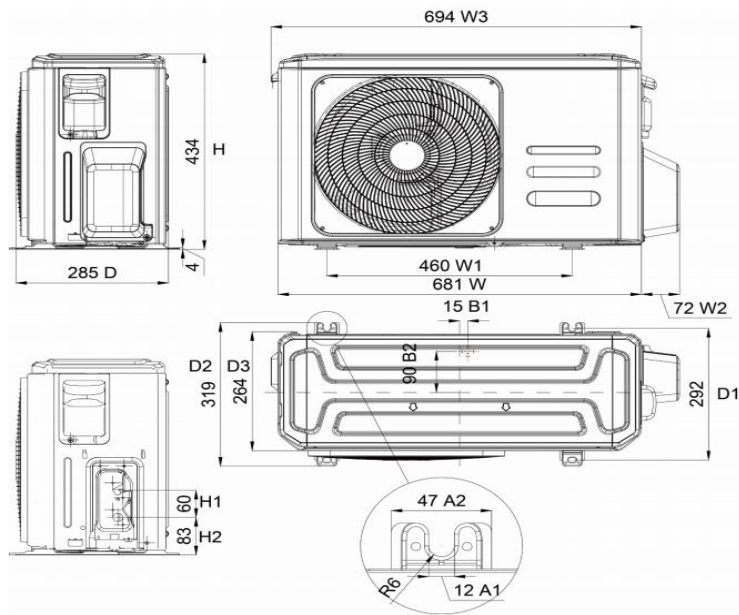

(The figure is for reference only)

Dimension(inch)	W	D	H
CT32-12CA (O)	28.3	10.6	19.5
CT32-12CD (O)	28.3	10.6	19.5
CT32-18CD (O)	30.1	11.9	21.9
CT32-24CD (O)	31.7	13.0	21.8