

SPLIT AIR CONDITIONERS

Service Manual

ComfortStar®

BAR4&LUC4

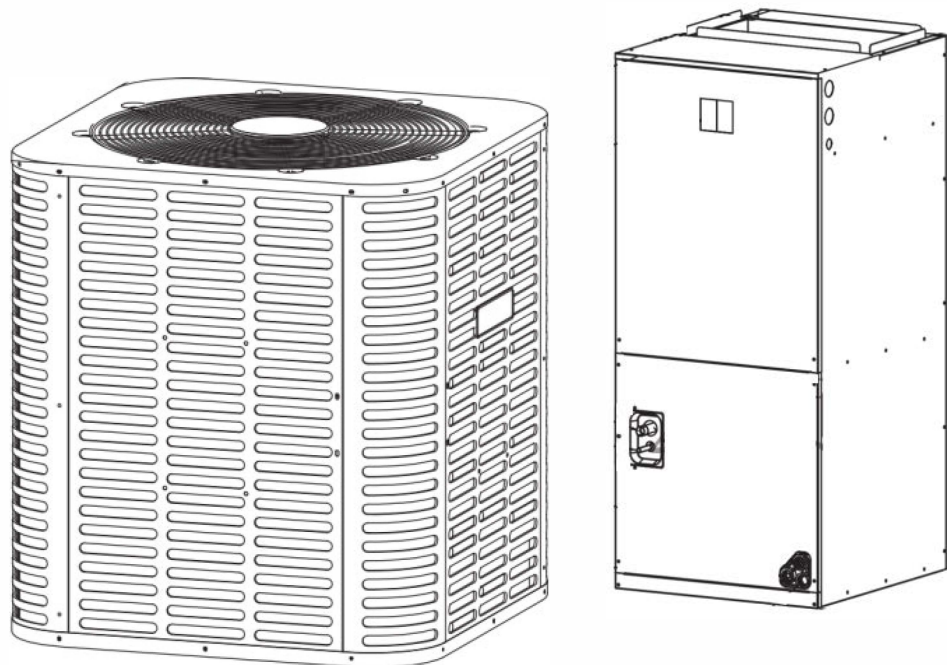

IMPORTANT NOTE:



Read this manual carefully before operating your new air conditioning unit. Make sure to save this manual for future reference.

Please check the applicable models, technical data, F-GAS(if any) and manufacturer information from the "Owner's Manual" in the packaging of the outdoor unit.

CONTENT

Part 1. General Information	1
1. Model Names of Indoor/Outdoor Units	2
2. External Appearance	3
3. Features	4
Part 2. Indoor Unit	1
1. Features	2
2. Dimension	4
3. Service Space	5
4. Wiring Diagrams	7
5. Electric Characteristics	8
6. Electrical Wiring	8
7. Field Wiring	8
Part 3 Outdoor Unit	1
1. Dimension	2
2. Service Space	3
3. Wiring Diagrams	4
4. Electric Characteristics	5
5. Operation Limits	6
6. Sound Levels	6
7. Refrigerate diagram	7
Part 4 Installation	1
1. Precaution on Installation	2
2. Emptying	4
3. Additional Refrigerant Charge	4
4. Insulation Work	5
Part 5 Unit maintenance	1
1. Fault indicator of indoor unit	2
2. Fault indicator of outdoor unit	2
3. Troubleshooting of Fault Codes	3

Part 1. General Information

1. Model names of Indoor/Outdoor unit.....	2
2. External Appearance.....	3
3. Features.....	4



1. Model Names of Indoor/Outdoor Units

1.1 Indoor Units

Model name	Dimension(W×H×D)(inch)	Power supply
15 SEER Cooling Only & Heat Pump		
LUC4-18-15	19-2/3×45-3/4×22	208/230V-1Ph-60Hz
LUC4-24-15	19-2/3×45-3/4×22	208/230V-1Ph-60Hz
LUC4-30-15	19-2/3×45-3/4×22	208/230V-1Ph-60Hz
LUC4-36-15	19-2/3×45-3/4×22	208/230V-1Ph-60Hz
LUC4-42-15	19-2/3×45-3/4×22	208/230V-1Ph-60Hz
LUC4-48-15	22×53-1/8×24-1/2	208/230V-1Ph-60Hz
LUC4-60-15	22×53-1/8×24-1/2	208/230V-1Ph-60Hz

1.2 Outdoor Units

Scroll Compressor Series

Model name	Dimension (W×H×D) (inch)	Power supply
15 SEER Cooling Only & Heat Pump		
BAR4-18-15	21-4/5×25×21-4/5	208/230V-1Ph-60Hz
BAR4-24-15	21-4/5×25×21-4/5	208/230V-1Ph-60Hz
BAR4-30-15	29-1/7×25×29-1/7	208/230V-1Ph-60Hz
BAR4-36-15	29-1/7×25×29-1/7	208/230V-1Ph-60Hz
BAR4-42-15	29-1/7×32-7/8×29-1/7	208/230V-1Ph-60Hz
BAR4-48-15	29-1/7×32-7/8×29-1/7	208/230V-1Ph-60Hz
BAR4-60-15	29-1/7×32-7/8×29-1/7	208/230V-1Ph-60Hz

2. External Appearance

2.1 Indoor unit



2.2 Outdoor unit



Note: Standard outdoor unit is using plastic grill. Metal grill can be customized.



Louvered steel grille

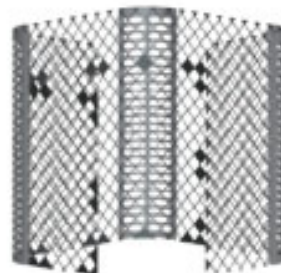

Plastic grille

3. Features

3.1 Operation features

- Long Piping & Cost Effective
- Low noise operation, as low as 42dB(A)
- 24V control, time delay relay, fan relay and transformer included.

3.2 Performance features

- AHRI Certified & ETL listed.
- R410A environment friendly refrigerant.
- Wide operation temperature range: Cooling: 58⁰F-115⁰F; Heating: 5⁰F-86⁰F
- Continuous Cooling Transformation Inner-grooved tube has high thermometric conductivity.

3.3 Reliability features

- Painted galvanized steel cabinet.
- Well-known brand scroll & rotary compressor, reliable quality.
- Condenser coils constructed with copper tubing and enhanced aluminum fins.
- 3-speed DC motors, provide selections of air flow to meet desired applications.
- Intelligent defrost programs, unit will choose different defrost program according to real condition.

Part 2. Indoor Unit

1.Features	2
2.Dimension	4
3.Service Space	5
4.Wiring Diagrams	7
5.Electric Characteristics	8
6.The Specification of Wiring	8
7.Field Wiring	8



1. Features

(1) "A" shape coils, constructed with copper tubing and enhanced aluminum fins.

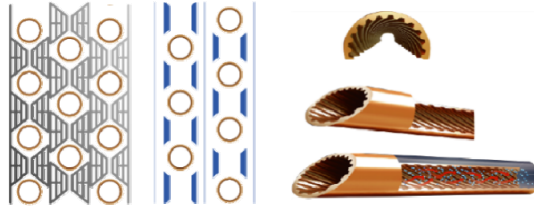

(2) ECM motors, the air handler has multiple fan modes to choose from, which can flexibly respond to various environments.

(3) $\phi 12''$ large fan blade that has powerful fan speed, and the motor is covered with insulation material, which can ensure that the motor runs in a safe state.

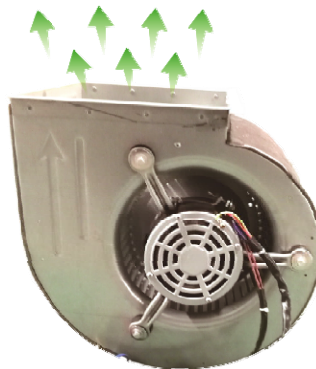

(4) Use Piston as throttle device



(5) Optional air filter (Optional)

Detachable air filter for cleaning or renewal, designed to provide fresh and healthy air indoors.

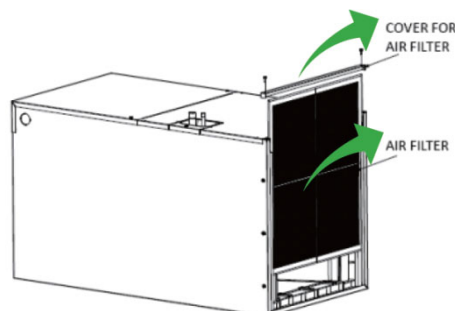

MODEL	FILTER SIZE IN[mm]
18/24/30/36/42	18.1×21.4[460×544]
48/60	20.5×23.8[521×605]

NOTE: The thickness of the filter should be within 1"[25mm].

(6) Electric Heating with Different Power (Optional)

SPEC. For 15 SEER AHU Electrical Heater		
SPEC.	Part No.	Model
5 kw	8024325A0001	18/24/30/36/42/48/60 K
7.5 kw	8024325A0002	
10 kw	8024325A0003	
15 kw	8024325A0004	36/42/48/60 K
20 kw	8024325A0005	48/60 K

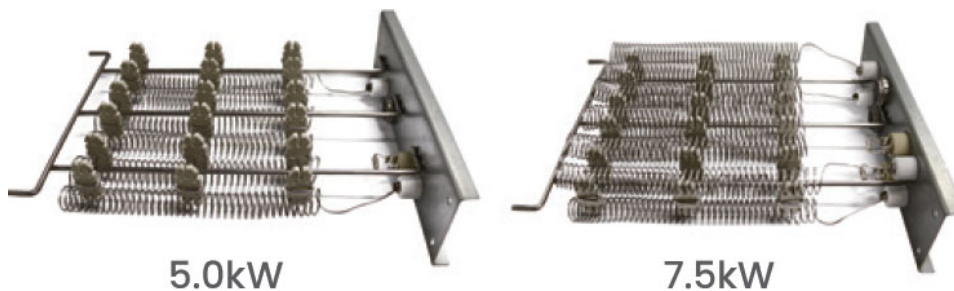

(7) Multi-position installation (Optional)

Versatile 4-way convertible design for vertical up airflow, vertical down airflow*, horizontal left airflow* and horizontal right airflow.

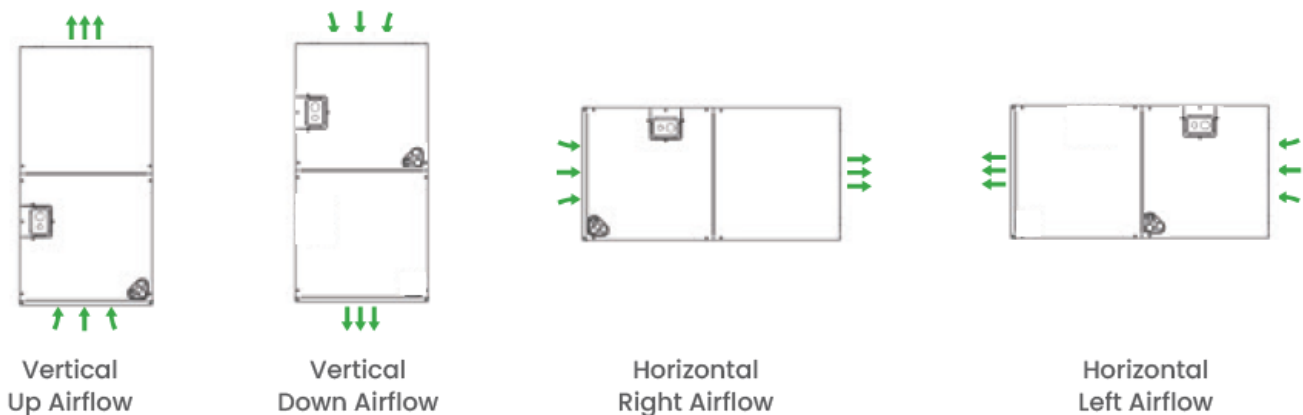

*: Vertical down airflow and Horizontal left airflow are optional.

2. Dimension

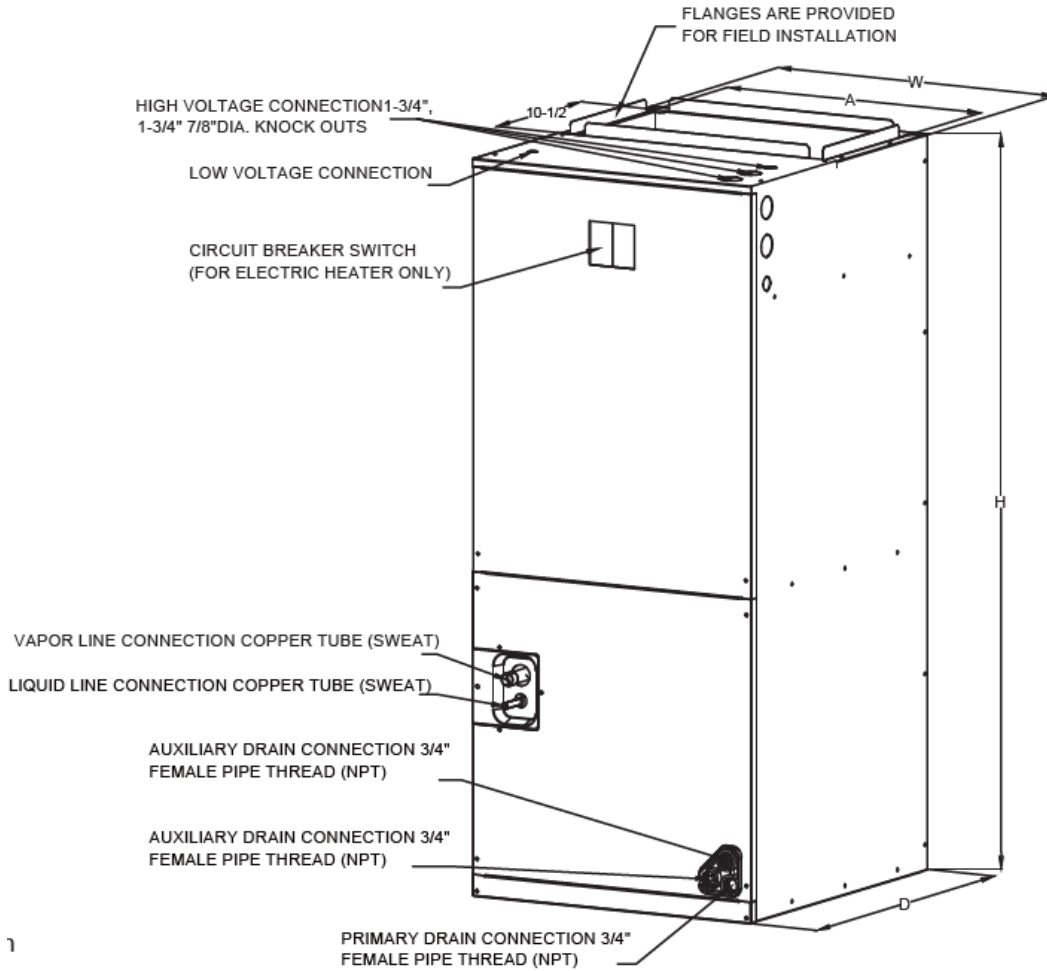

Model	Dimension Inches (mm)				
	Height "H"	Width "W"	Depth "D"	Air outlet "A"	Liquid Line/Vapor Line
18K	45-3/4	19-2/3	22	17-7/8(454)	3/8 /3/4(9.5)/(19)
24K	45-3/4	19-2/3	22	17-7/8(454)	3/8 /3/4(9.5)/(19)
30K	45-3/4	19-2/3	22	17-7/8(454)	3/8 /3/4(9.5)/(19)
36K	45-3/4	19-2/3	22	17-7/8(454)	3/8 /3/4(9.5)/(19)
42K	45-3/4	19-2/3	22	17-7/8(454)	3/8 /3/4(9.5)/(19)
48K	53-1/8	22	24	19-1/2(496)	3/8 /7/8(9.5)/(22)
60K	53-1/8	22	24	19-1/2(496)	3/8 /7/8(9.5)/(22)

3. Service Space

The indoor unit should be installed in a location that meets the following requirements:

INSTALLATION NOTES:

1. For vertical upward airflow (Standard), the position and dimension of rubber plugs and traps of drain pipes are as follows:

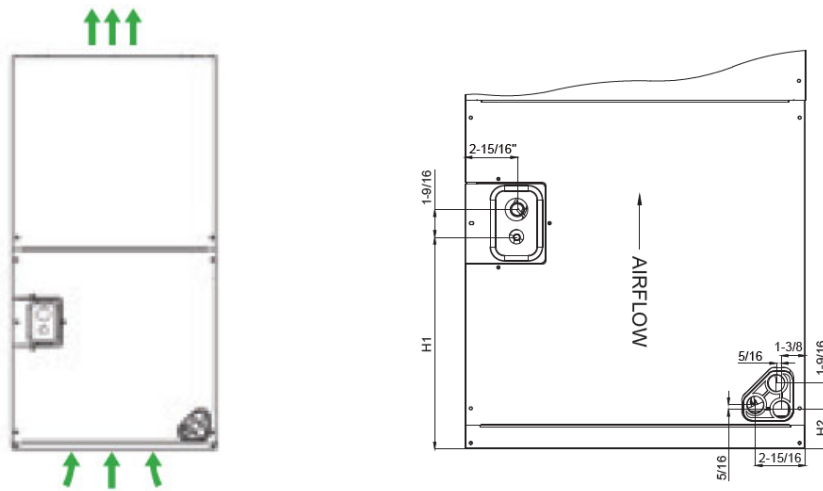

Model	"H1" inch [mm]	"H2" inch [mm]
18K/24K/30K/36K/42K	12-1/4 [311]	2-1/4[57]
48K/60K	19[483]	1-25/32[45]

2. The vertical upward airflow position can be converted into the vertical downward airflow position(Optional). Remove the coil (evaporator) access panel and coil, and reinstall it by rotating 180 ° from the original position. The position and dimension of seal plugs of drain pipes are as follows:

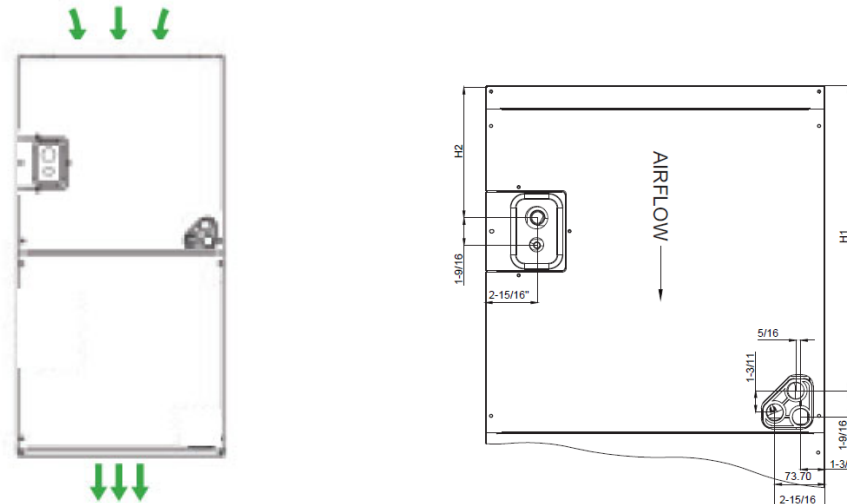

Model	"H1" inch [mm]	"H2" inch [mm]
18K/24K/30K/36K/42K	17-11/16 [449]	7-9/16 [192]
48K/60K	21-11/16 [551]	4-13/32 [112]

3. For horizontal right airflow (Standard), the position and dimension of seal plugs of drain pipes are as follows:

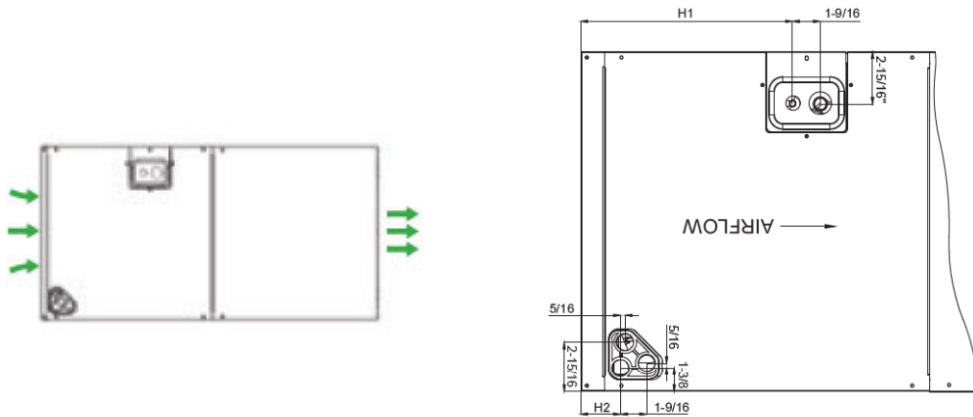

Model	"H1" inch [mm]	"H2" inch [mm]
18K/24K/30K/36K/42K	12-1/4 [311]	2-1/4 [57]
48K/60K	19 [483]	1-25/32 [45]

4. For horizontal left airflow (Optional), the position and dimension of seal plugs of drain pipes are as follows:

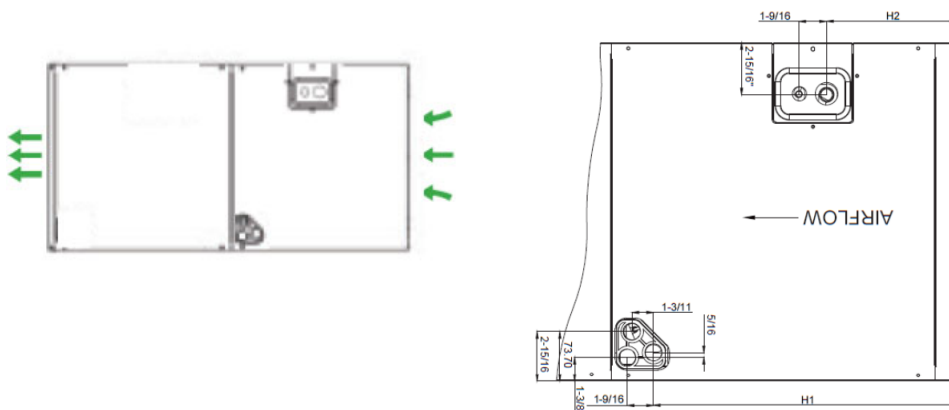

Model	"H1" inch [mm]	"H2" inch [mm]
18K/24K/30K/36K/42K	17-11/16 [449]	7-9/16 [192]
48K/60K	21-11/16 [551]	4-13/32 [112]

Remark: Please refer to the installation manual for more installation information.

5. The seal-plugs are supplied as accessories and be screwed tightly only with hand.

4. Wiring Diagrams

18K/24K/30K/36K/42K/48K/60K

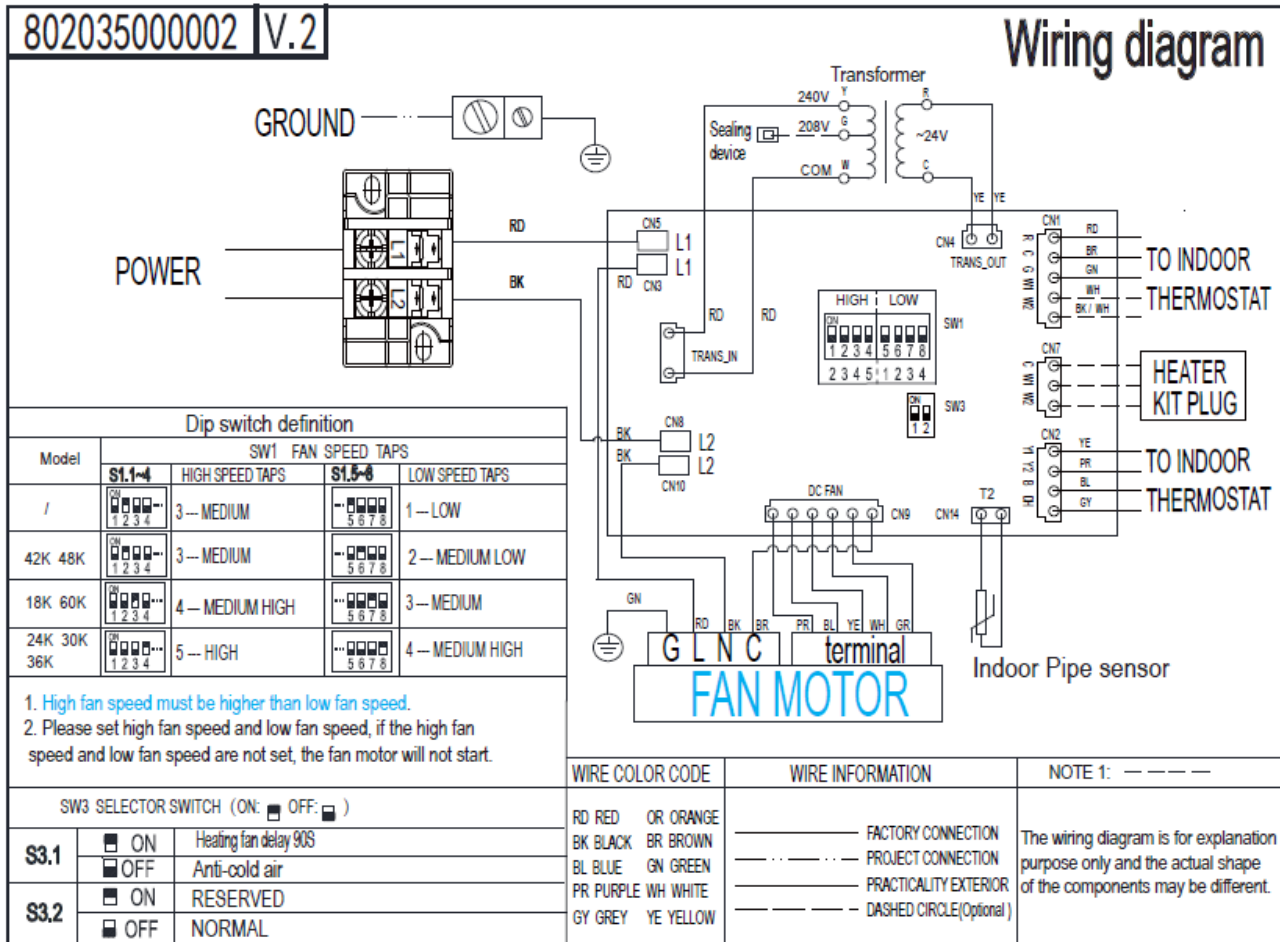

5. Electric Characteristics

Model	Voltage	Hertz	HP	Wind speed	Circuit AMPS	Maximum circuit protector
18K	208/230	60	1/3	5	0.8	5 (A)
24K	208/230	60	1/3	5	1.1	5 (A)
30K	208/230	60	1/2	5	1.3	5 (A)
36K	208/230	60	1/2	5	2.0	5 (A)
42K	208/230	60	3/4	5	2.2	5 (A)
48K	208/230	60	3/4	5	2.2	5 (A)
60K	208/230	60	3/4	5	3.5	5 (A)

6. Electrical Wiring

Note:

The diameters of wires or lines should not be less than the corresponding ones listed in the table below; Besides, if the power wires is quite long from the unit, please choose the winding with larger cross-section area to guarantee the normal power supply.

Type (Btu/ hour)		18K	24K	30K	36K	42K	48K	60K	
Power	Stage	Single							
	Voltage/frequency	208/230VAC, 60 Hz							
Wire gauge	Indoor unit power cord	Line quantity	3	3	3	3	3	3	3
		Wire diameter (AWG)	16	16	16	16	16	16	16
	Outdoor unit power cord	Line quantity	3	3	3	3	3	3	3
		Wire diameter (AWG)	14	14	12	12	10	10	10

7. Field Wiring

1. To avoid the electrical shock, please connect the air conditioner with the ground lug. The main power plug in the unit has been joined with the ground wiring, please don't change it freely.
2. The power socket is used as the air conditioner specially.
3. Don't pull the power wiring hard.
4. When connecting the air conditioner with the ground, observe the local codes.
5. If necessary, use the power fuse or the circuit, breaker or the corresponding scale ampere.

Remark: Please refer to the installation manual for more different kinds of wiring information.

Part 3 Outdoor Unit

1. Dimensions	2
2. Service Space	3
3. Wiring Diagrams	4
4. Electric Characteristics	5
5. Operation Limits	6
6. Sound Levels	6
7. Refrigerate diagram	7



1. Dimension

When installing the outdoor unit on the roof, make sure that the roof can support the weight of the outdoor unit. It is recommended to choose appropriate isolation to prevent sound or vibration from being transmitted to the building structure.

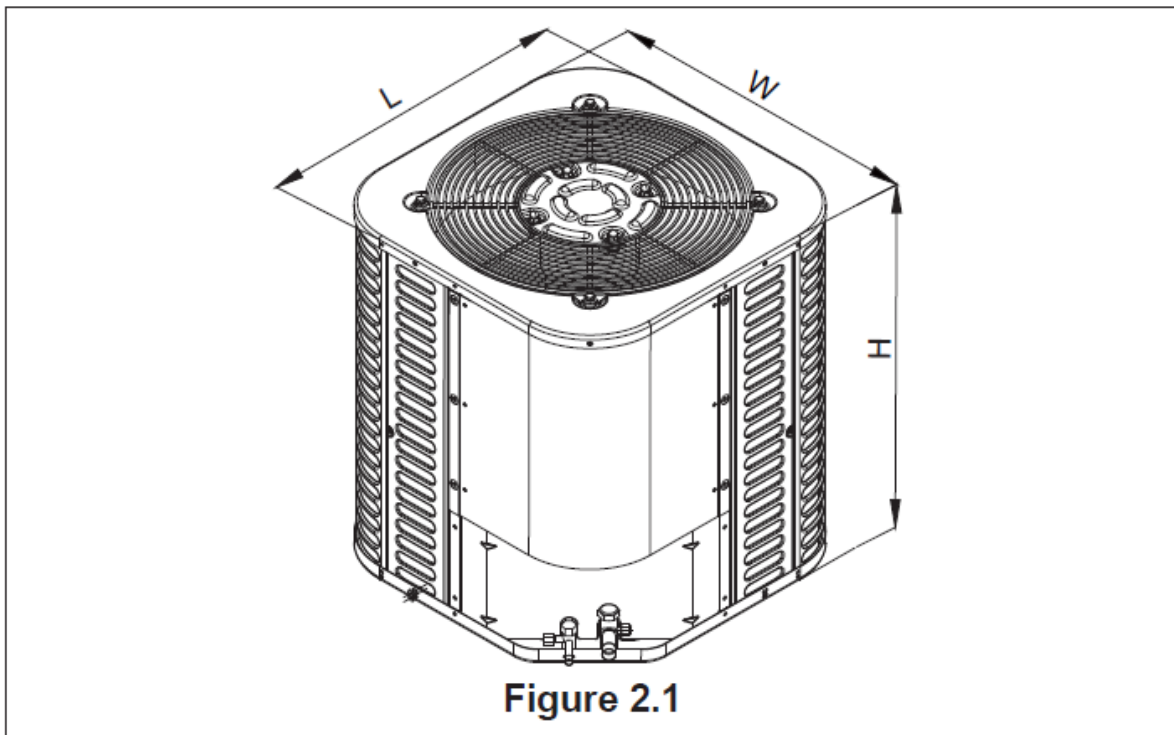
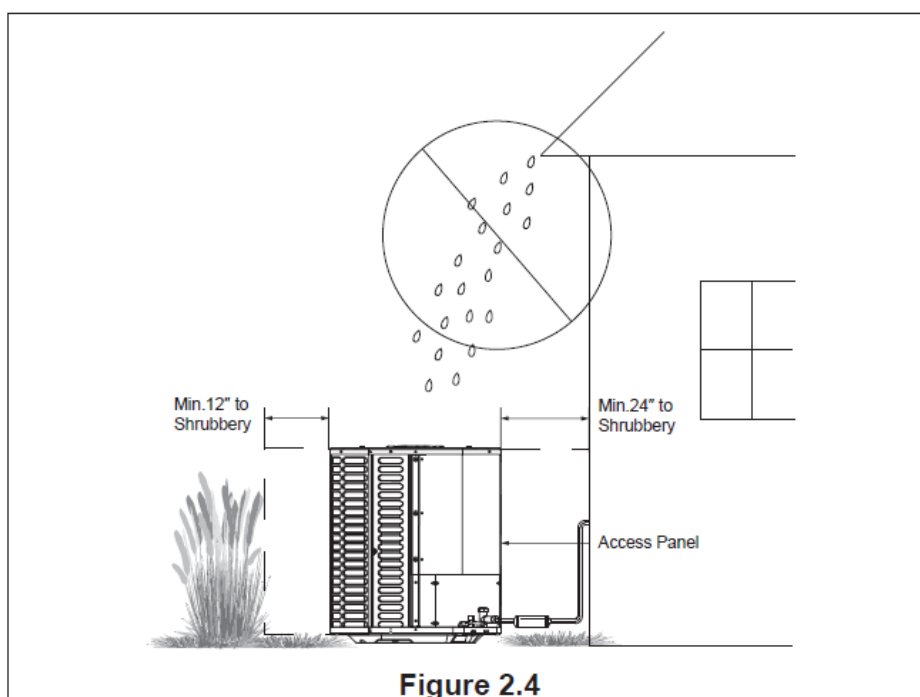
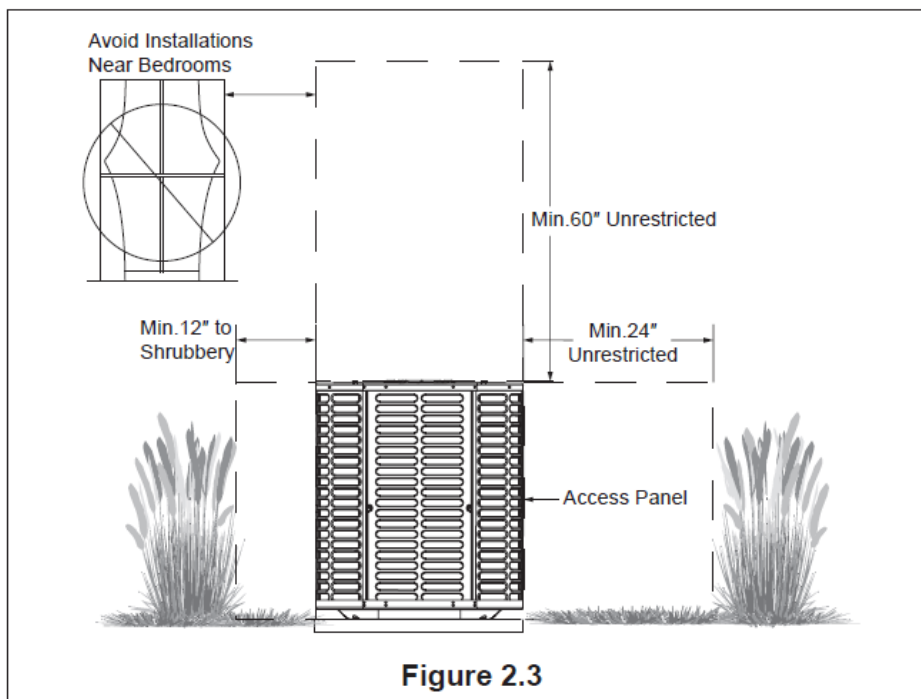

Figure 2.1

Model	Dimension Inches (mm)
	(HxWxL)
18K	21-4/5x25x21-4/5
24K(AC)	
24K(HP)	29-1/7x25x29-1/7
30K	
36K	
42K	29-1/7x32-7/8x29-1/7
48K	
60K	

2. Service Space

1. Make sure that the discharge area at least 60 inches above the top of the unit is unrestricted.
2. The clearance from one side of the access panel to the wall should be at least 24 inches.
3. Except for access panel, please leave a min 12" from shrubbery around other side panels.



3. Wiring Diagrams

Cooling only

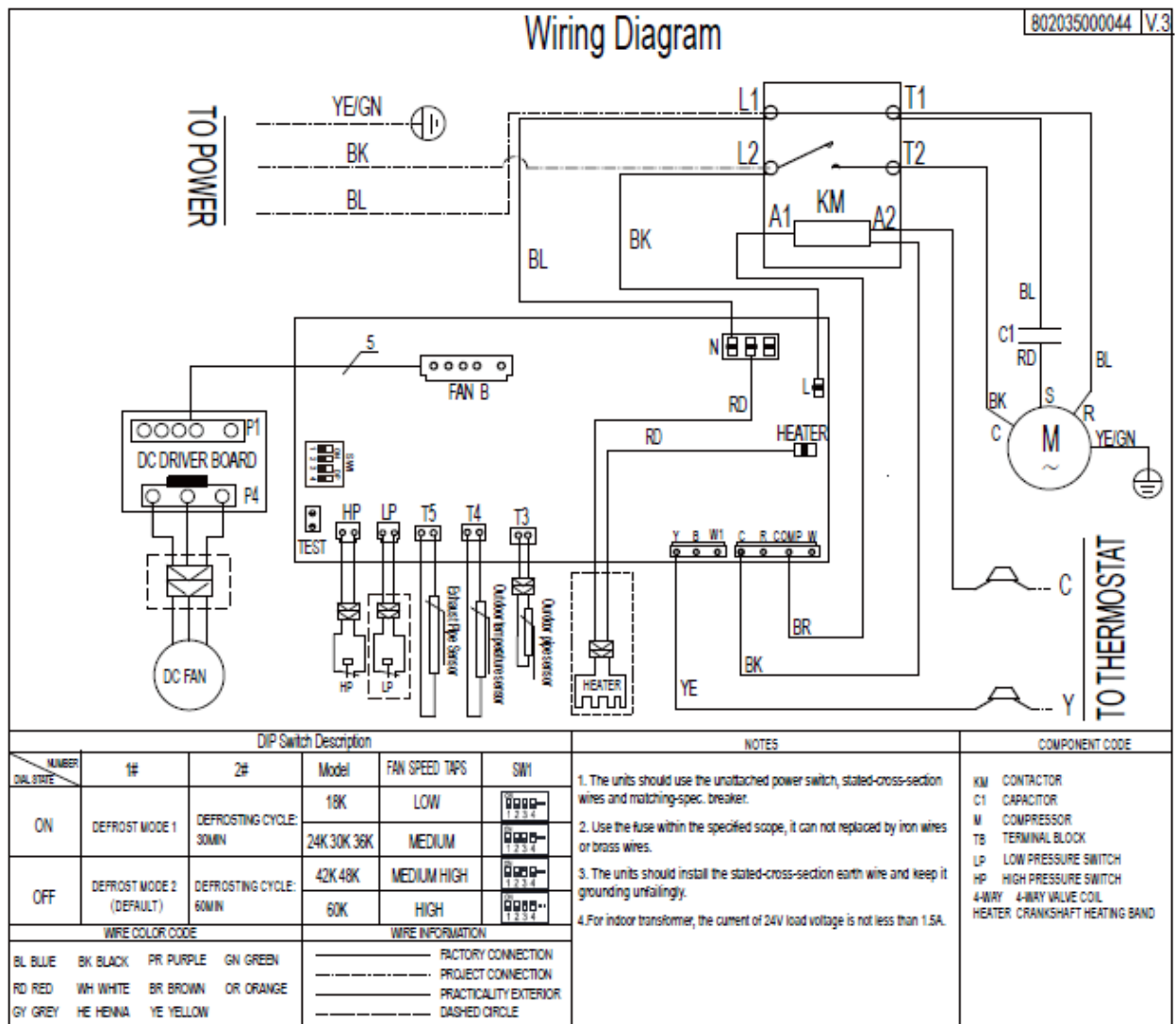

4. Electric Characteristics

Model	Outdoor Unit (Scroll)					
	Hz	Voltage	Min.	Max.	MIN. Circuit Ampacity	Maxi Fuse
BAR4-18-15	60	208/230V	187V	253V	13	20
BAR4-24-15					13	20
BAR4-30-15					15	25
BAR4-36-15					20	30
BAR4-42-15					25	40
BAR4-48-15					30	45
BAR4-60-15					33	50

5. Operation Limits

Operation mode	Outdoor temperature (°F)
Cooling operation	65~115
Heating operation	5~86

6. Sound Levels

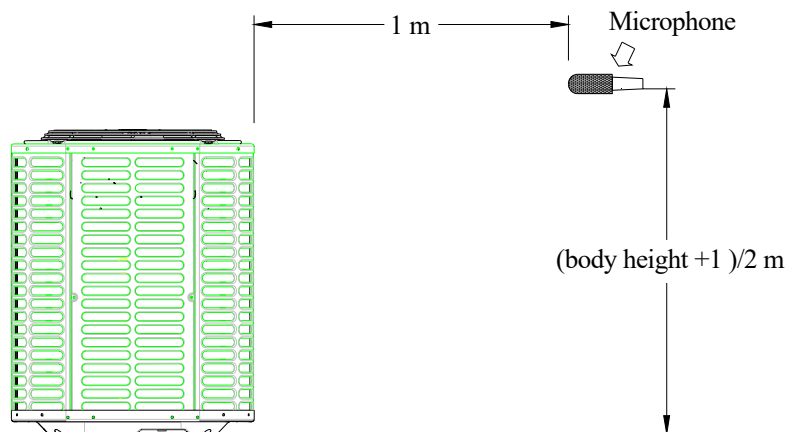

Model	Noise level dB(A)
18K	60
24K	60
30K	61
36K	61
42K	63
48K	63
60K	63

Note: Sound level is measured at a point 1 m in front of the unit, at a height of (Unit body height + 1)/2 m.

7. Refrigerate diagram

Applicable for cooling only type

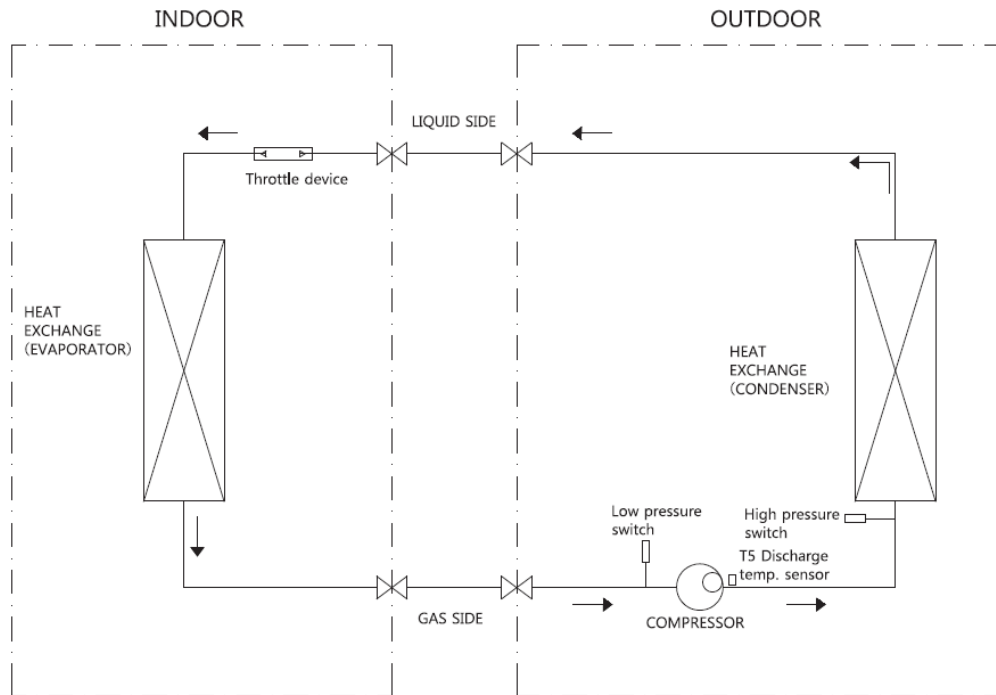

Applicable for heat pump type

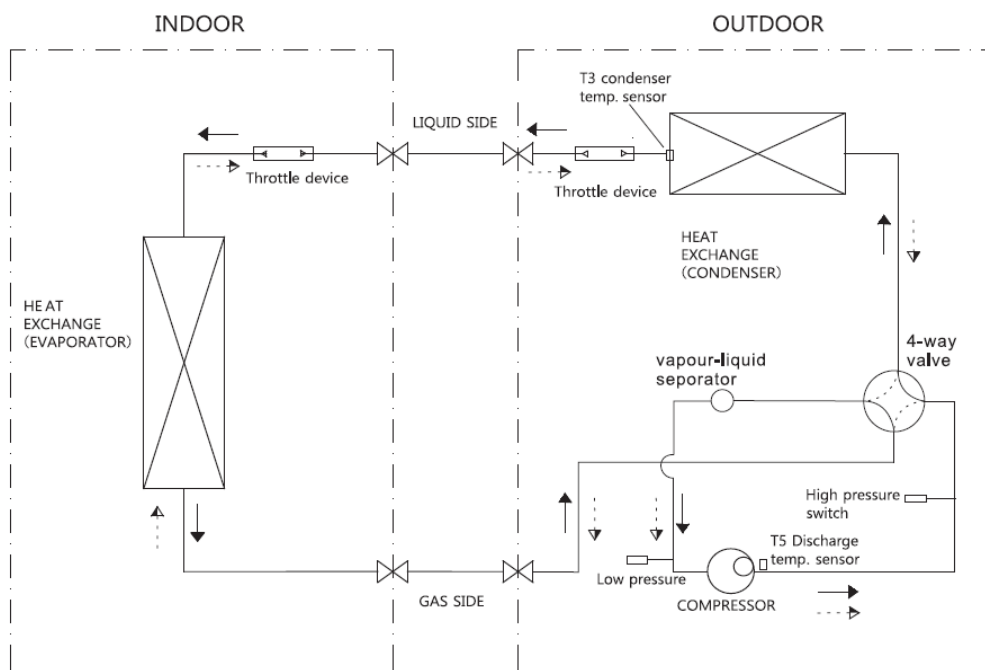

Note: In heating mode, the throttling device is outdoor unit piston; In cooling mode, the throttle device is indoor unit piston.

Part 4 Installation

1 .Precaution on Installation	2
2. Emptying	4
3. Additional Refrigerant Charge	4
4. Insulation Work	5

1. Precaution on Installation

1.1 Measure the necessary length of the connecting pipe, and make it by the following way

a. Connect the indoor unit at first, then the outdoor unit. Bend the tubing in proper way.

CAUTIONS:

- Daub the surfaces of the flare pipe and the joint nuts with frozen oil, and wrench it for 3~4 rounds;
 - Fasten the flare nuts;
 - Be sure to use two wrenches simultaneously when you connect or disconnect the pipes.
- b. The stop value of the outdoor unit should be closed absolutely (as original state). Every time you connect it, first loosen the nuts at the part of stop value, then connect the flare pipe immediately (in 5 minutes). If the nuts have been loosened for a long time, dusts and other impurities may enter the pipe system and may cause malfunction later. So please expel the air out of the pipe with refrigerant before connection.
- c. Emptying the air after connecting the refrigerant pipe with the indoor unit and the outdoor unit. Then fasten the nuts at the repair-points.

1.2 Locate the Pipe

- a. Drill a hole in the wall (suitable just for the size of the wall conduit), then set on the fittings such as the wall conduit and its cover.
- b. Bind the connecting pipe and the cables together tightly with binding tapes. Do not let air in, which will cause water leakage by condensation.
- c. Pass the bound connecting pipe through the wall conduit from outside. Be careful of the pipe allocation to do no damage to the tubing.
- d. Insulate the pipeline from all piping systems.
- e. Try to reduce the number of 90° laps.

1.3 Connect the pipes

Connecting Dimensions of Refrigerant Lines and Service Valves are shown as below table:

Model	Suction line	Liquid line	Suction line connection	Liquid line connection
	The dimensions are in inches.			
18K/24K/30K/36K/42K	3/4	3/8	3/4	3/8
48K/60K	7/8	3/8	7/8	3/8

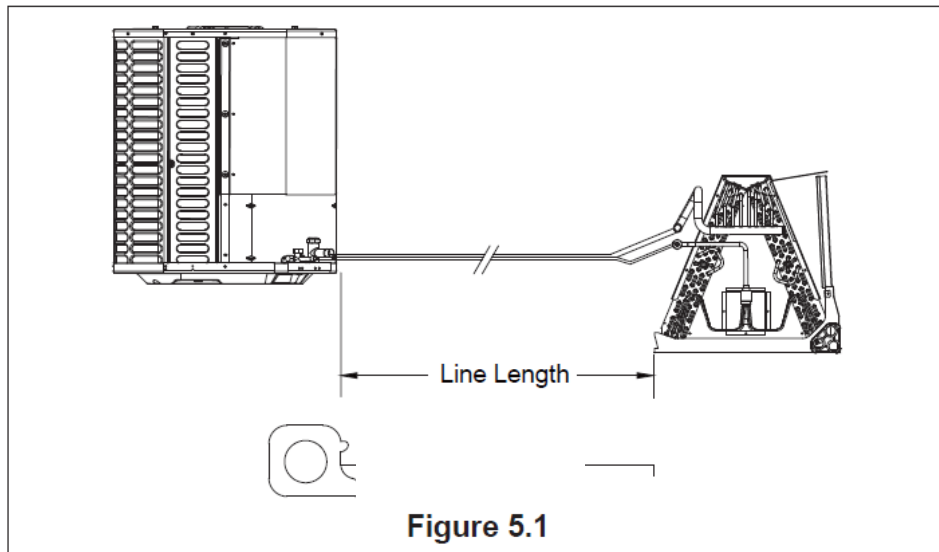

1.4 Refrigerant Pipeline Leakage Inspection

- a. Use dry nitrogen to pressurize the refrigerant line and evaporator coil to 150 PSIG.

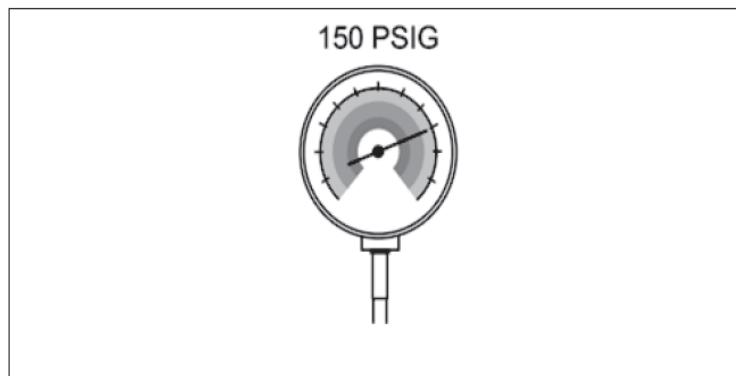

- b. Use soapy water or foam at each soldering position to check for leaks.

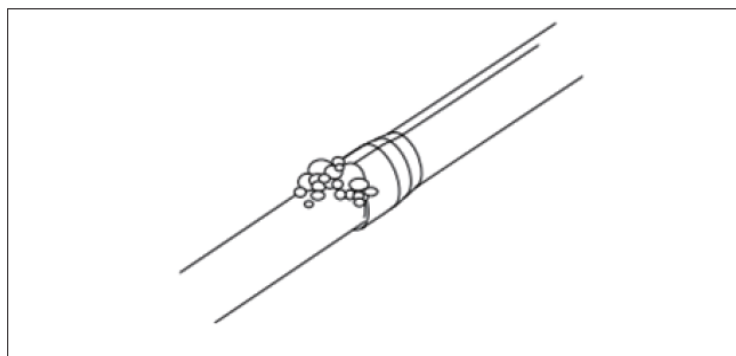

1.5 Then, open the stem of stop valves of the outdoor unit to make the refrigerant pipe connecting the indoor unit with the outdoor unit in fluent flow.

1.6 Cover the joint of the connecting pipe to the indoor unit with the soundproof / insulating sheath (fittings), and bind it well with the tapes to prevent leakage.

2. Emptying

CAUTIONS:

Do not open the service valve until the leakage inspection and emptying of refrigerant lines and indoor coils are completed.

1. Evacuate until the micrometer reading is not higher than 350 micrometers, and then close the valve of the vacuum pump.
2. Observe micrometer gauge. If the micrometer meter does not rise above 500 micrometers within one (1) minute, the evacuation is completed.

After the evacuation, turn off the vacuum pump and micrometer, and close the valve on the manifold instrument cluster.

3. Additional Refrigerant Charge

CAUTIONS:

- Refrigerant cannot be charged until field wiring has been completed.
- Refrigerant may only be charged after performing the leak test and the vacuum pumping.
- When charging a system, care shall be taken that its maximum permissible charge is never exceeded, in view of the danger of liquid hammer.
- Charging with an unsuitable substance may cause explosions and accidents, so always ensure that the appropriate refrigerant is charged.
- Refrigerant containers shall be opened slowly.
- Always use protective gloves and protect your eyes when charging refrigerant.

The outdoor unit is charged with refrigerant from factory. Calculate the additional refrigerant according to the diameter and the length of the liquid side pipe of the outdoor unit/indoor unit. There are two methods for additional refrigerant charging:

1. During the initial installation, or when the refrigerant quantity of the updated system is charged, the **weighing method** is used. All models have a charge factor of 0.6 oz / ft for refrigerant pipe length.

Model	Refrigerant pipeline length	Charge factor
All models	≤25ft	Factory charge data on nameplate
	>25ft	0.6 oz / ft

2. When the outdoor ambient temperature is higher than 55°F, recommending use **subcooling (cooling mode) charging method**. For outdoor ambient temperature below 55°F, use the weighing charging method.

Remark: Please go to the 14th part of the installation manual for more charging details.

4. Insulation Work

4.1 Insulation material and thickness

1. Insulation material

Insulation material should adopt the material which is able to endure the pipe's temperature: no less than 70°C in the high-pressure side, no less than 120°C in the low-pressure side (For the cooling type machine, no requirements at the low-pressure side.)

- ◆ Example: Heat pump type----Heat-resistant Polyethylene foam (withstand above 120°C)
Cooling only type----Polyethylene foam (withstand above 100°C)

2. Thickness choice for insulation material

Insulation material thickness is as follows:

	Pipe diameter (mm)	Adiabatic material thickness
Refrigerant pipe	Φ6.4—Φ25.4	10mm
	Φ28.6—Φ38.1	15mm
Drainage pipe	Inner diameterΦ20—Φ32	6mm

4.2 Refrigerant pipe insulation

1. Work Procedure

- ① Before laying the pipes, the non-jointing parts and non-connection parts should be heat insulated.
- ② When the gas proof test is eligible, the jointing area, expanding area and the flange area should be heat insulated.

2. Insulation for non-jointing parts and non-connection parts

wrong	right	
Gas pipe and liquid pipe should not be put together to insulate	Insulate the gas pipe (cooling only)	Insulate the gas pipe and liquid pipe

For construction convenience, before laying pipes, use insulation material to insulate the pipes to be deal with, at the same time, at two ends of the pipe, remain some length not to be insulated, in order to be welded and check the leakage after laying the pipes.

3. Insulate for the jointing area, expanding area and the flange area

- ① Insulate for the jointing area, expanding area and the flange area should be done after checking leakage of the pipes
- ② Make sure there's no clearance in the joining part of the accessorial insulation material and local preparative insulation material.

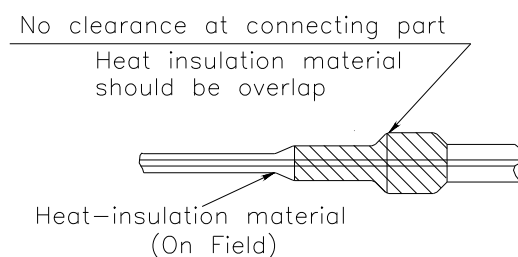

4.3 Drainage pipe insulation

The connection part should be insulated, or else water will be condensing at the non-insulation part.

4.4 Note

1. The jointing area, expanding area and the flange area should be heat insulated after passing the pressure test.
2. The gas and liquid pipe should be heat insulated individually, the connecting part should be heat insulated individually.
3. Use the attached heat-insulation material to insulate the pipe connections (pipes' tie-in, expand nut) of the indoor unit.

Part 5 Unit maintenance

1. Fault indicator of indoor unit	2
2. Fault indicator of outdoor unit	2
3. Troubleshooting of Fault Codes	3

1. Fault indicator of indoor unit

The meaning of the fault indicator:

Content		Description
Normal display	Unit is standby	Green light flash 1 time every 3 seconds
	Unit is running normally	Green light ON
Outdoor unit error: Green light flashing	T2 temp. sensor error	Green light flash 2 time for every 8s
	Anti-cold air	Green light flash 3 times for every 8s

2. Fault indicator of outdoor unit

The meaning of the fault indicator:

Content		Description
Normal display: green light flashes, yellow light OFF	Green light flash slow	Unit standby
	Green light ON	Unit is running
Outdoor unit error: Green light slow flash, Yellow light flashing	T3 temp. sensor error	Yellow light flash 1 time for every 8s
	T4 temp. sensor error	Yellow light flash 2 times for every 8s
	T5 temp. sensor error	Yellow light flash 3 times for every 8s
	Low pressure protection	Yellow light flash 4 times for every 8s
	High pressure protection	Yellow light flash 5 times for every 8s
	T3 high temperature protection	Yellow light flash 6 times for every 8s
	T5 high temperature protection	Yellow light flash 7 times for every 8s
Outdoor unit error & locked: Green light ON, Yellow light flash	Fan motor feedback error	Yellow light flash 8 times for every 8s (Only for DC fan motor)
	Low pressure protection occurs 6 times within 60 mins	Yellow light flash 4 times for every 8s
	Low pressure protection occurs 6 times within 60 mins	Yellow light flash 5 times for every 8s
	T3 high temp. protection occurs 6 times within 60 mins	Yellow light flash 6 times for every 8s
	T5 high temp. protection occurs 3 times within 20 mins	Yellow light flash 7 times for every 8s

3. Troubleshooting of Fault Codes

3.1 T3 Condenser Temperature sensor error

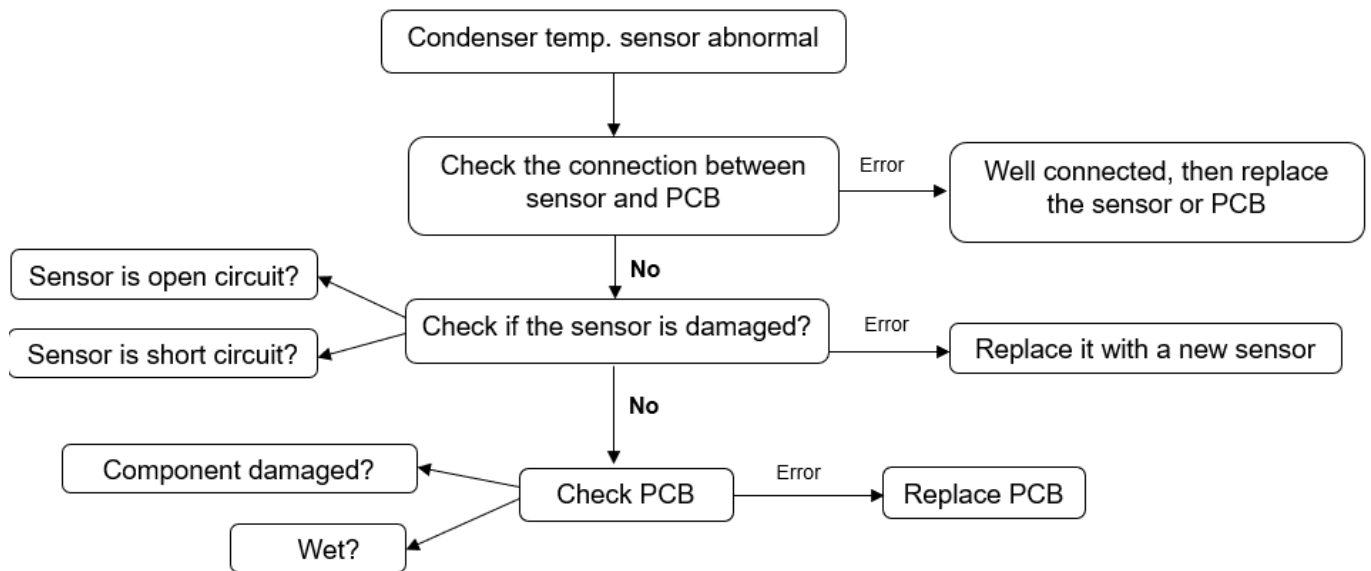

3.2 T4 Outdoor Ambient Temperature sensor error

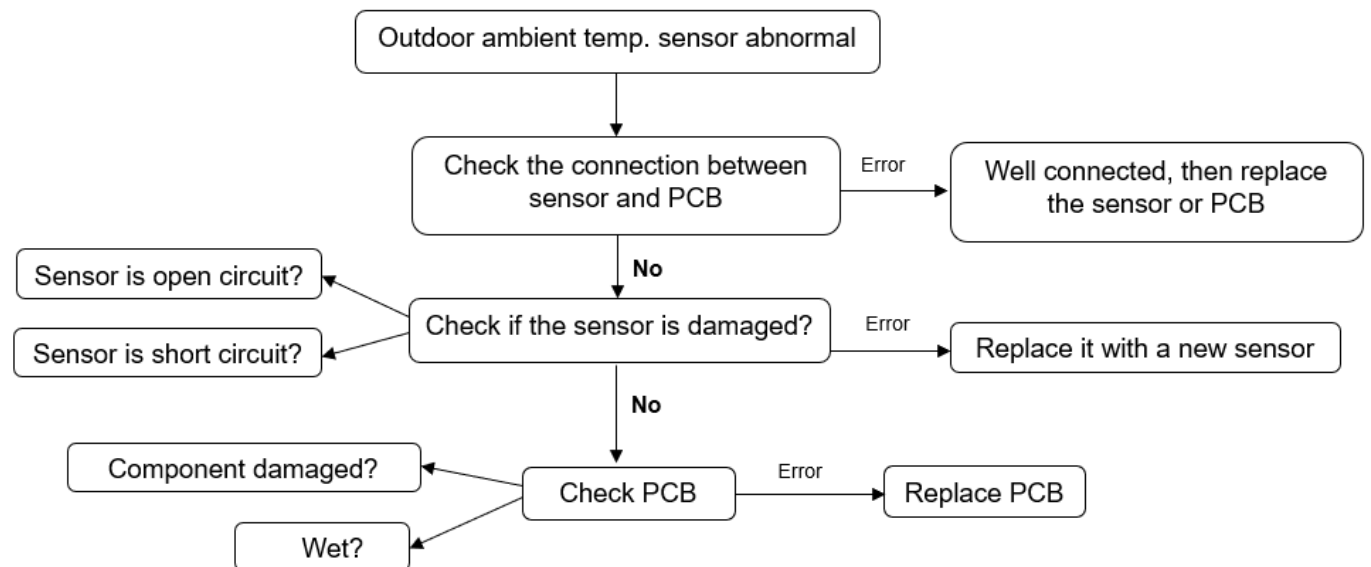

3.3 T5 Discharge Temperature sensor error

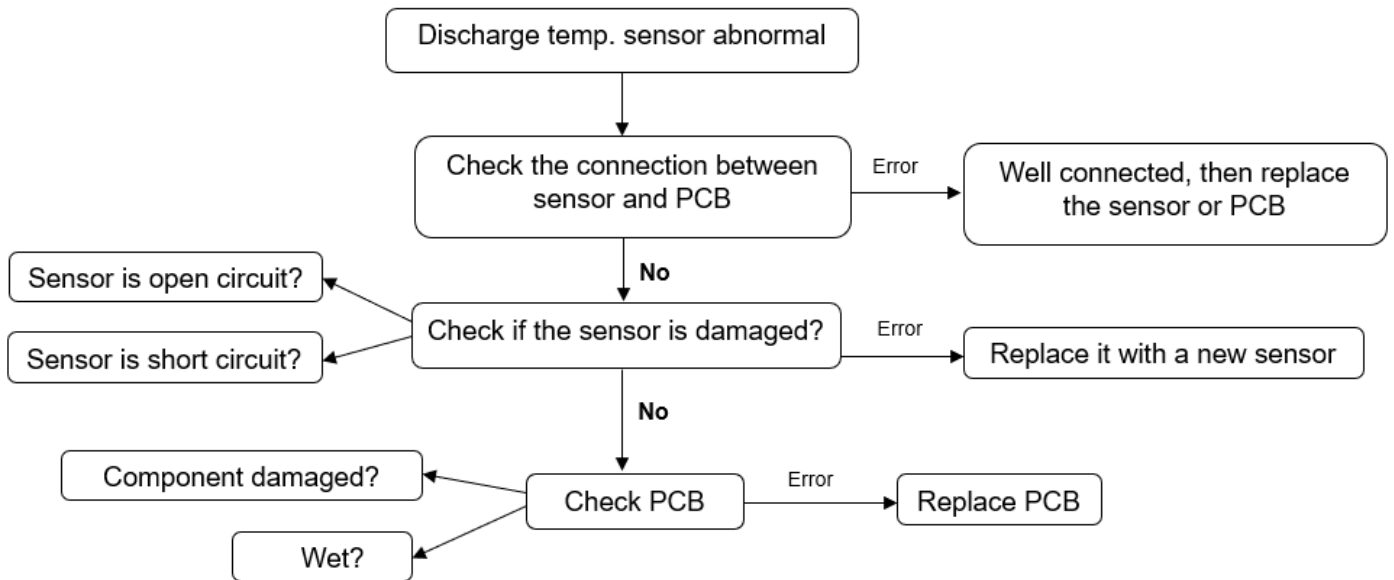

3.4 Low Pressure alarm

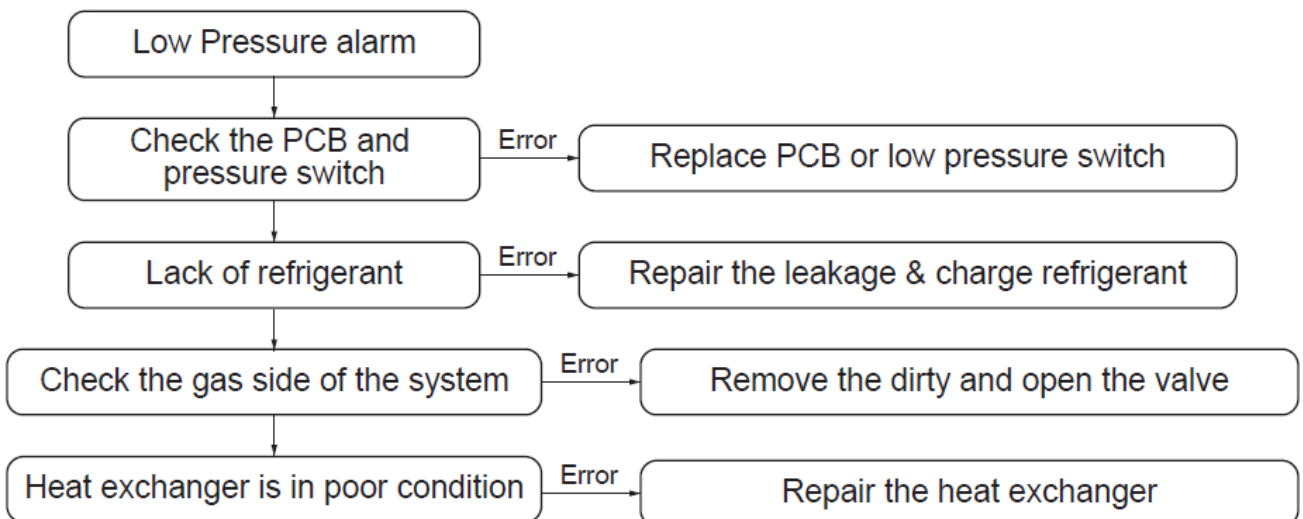

3.5 High Pressure alarm

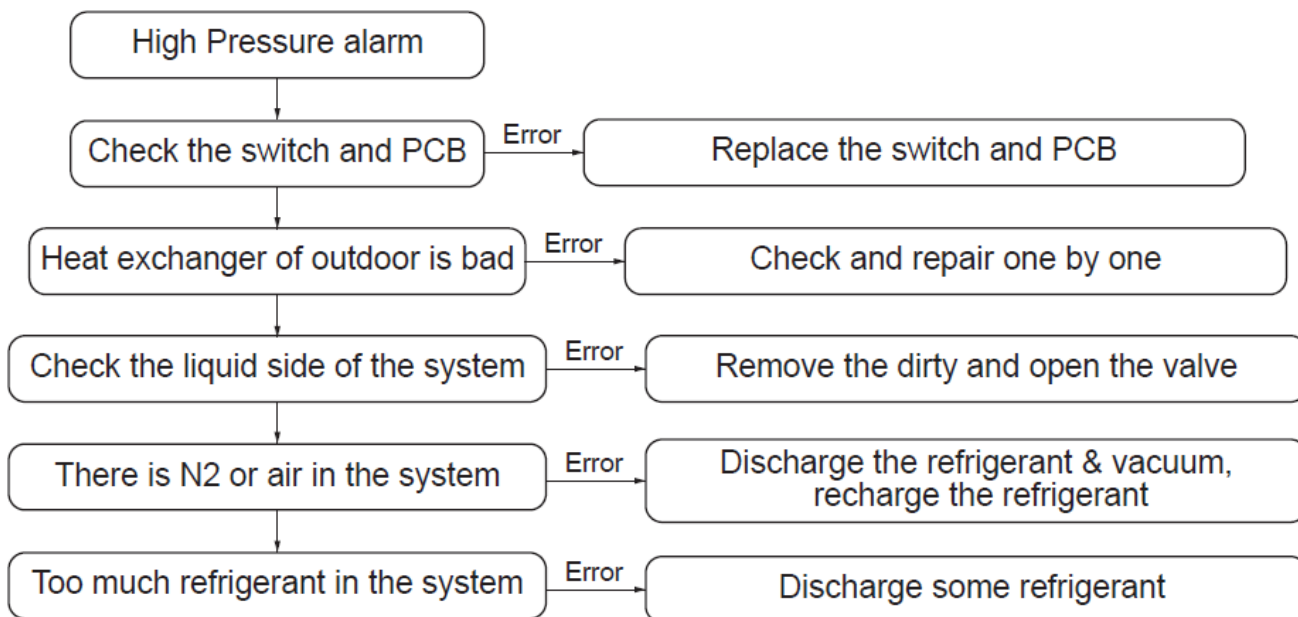

3.6 T3 high temperature protection

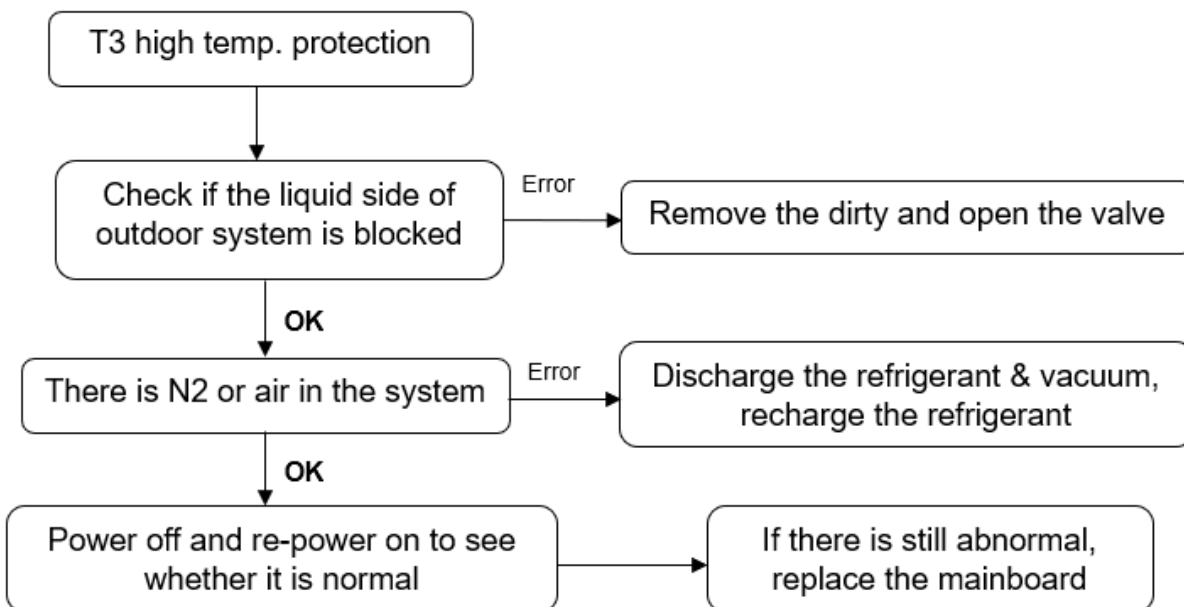

3.7 T5 high temperature protection

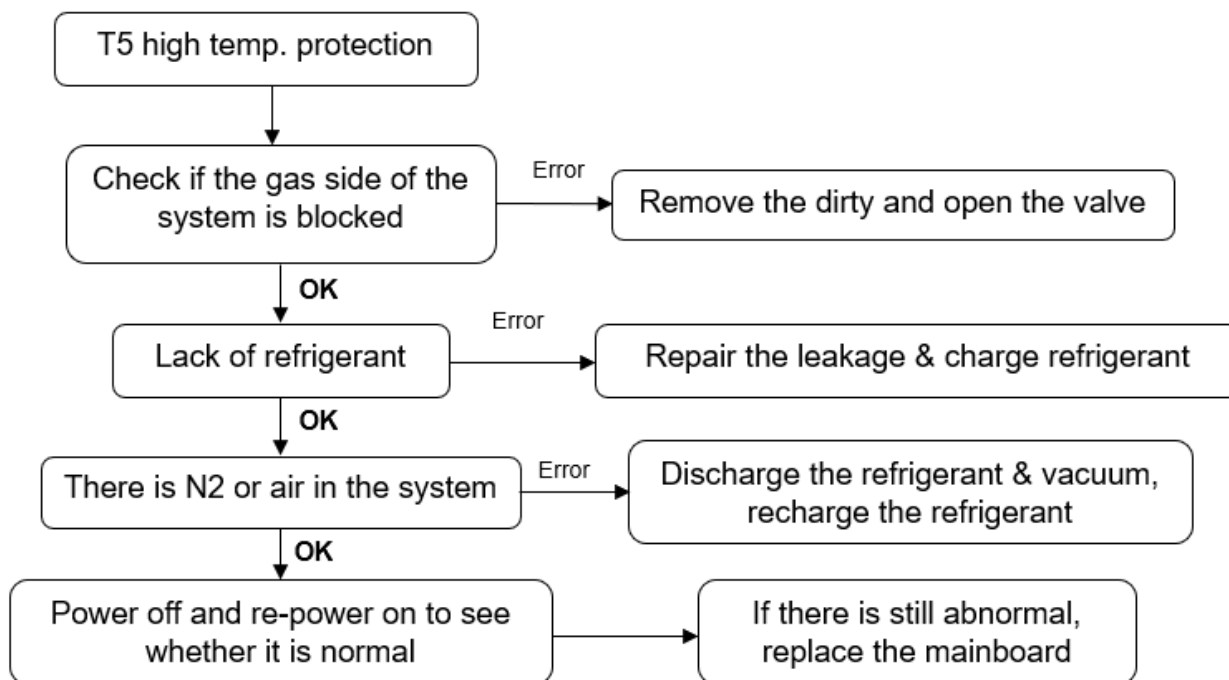

3.8 Fan motor feedback error

