

SPLIT AIR CONDITIONERS

Service Manual

ComfortStar®

INVERTER_CAC SERIES

IMPORTANT NOTE:



Read this manual carefully before operating your new air conditioning unit. Make sure to save this manual for future reference.

Please check the applicable models, technical data, F-GAS(if any) and manufacturer information from the "Owner's Manual" in the packaging of the outdoor unit.



**Caution: Risk of fire
(Required for R32/R290
units only)**

Table of Contents

§. Safety Precautions

1. Precautions
2. Information servicing(For flammable materials)

§. Specifications

1. Model Reference
2. Pipe length and the Drop Height
3. Refrigerant Cycle Diagrams
4. Electrical Wiring Diagrams

§. Product Features

1. Display Function
2. Safety Features
3. Basic Features

§. Maintenance

1. First Time Installation Check
2. Refrigerant Recharge
3. Re-Installation

§. Troubleshooting

1. Safety Caution
2. General Troubleshooting
3. Complain Record Form
4. Information Inquiry
5. Error Diagnosis and Troubleshooting Without Error Code
6. Quick Maintenance by Error Code
7. Troubleshooting by Error Code
8. Check Procedures

Appendix

- i) Temperature Sensor Resistance Value Table for T1,T2,T3 and T4 (°C – K)
- ii) Temperature Sensor Resistance Value Table for TP(for some units) (°C – K)
- iii) Pressure On Service Port

Safety Precautions

Contents

1.	Precautions.....	2
2.	Information servicing(For flammable materials).....	3

1. Precautions

To prevent personal injury, or property or unit damage, adhere to all precautionary measures and instructions outlined in this manual. Before servicing a unit, refer to this service manual and its relevant sections.

Failure to adhere to all precautionary measures listed in this section may result in personal injury, damage to the unit or to property, or in extreme cases, death.

 **WARNING** indicates a potentially hazardous situation which if not avoided could result in serious personal injury, or death.

 **CAUTION** indicates a potentially hazardous situation which if not avoided could result in minor or moderate personal injury, or unit damage.

1.1 In case of Accidents or Emergency

 **WARNING**

- If a gas leak is suspected, immediately turn off the gas and ventilate the area if a gas leak is suspected before turning the unit on.
- If strange sounds or smoke is detected from the unit, turn the breaker off and disconnect the power supply cable.
- If the unit comes into contact with liquid, contact an authorized service center.
- If liquid from the batteries makes contact with skin or clothing, immediately rinse or wash the area well with clean water.
- Do not insert hands or other objects into the air inlet or outlet while the unit is plugged in.
- Do not operate the unit with wet hands.
- Do not use a remote controller that has previously been exposed to battery damage or battery leakage.

 **CAUTION**

- Clean and ventilate the unit at regular intervals when operating it near a stove or near similar devices.
- Do not use the unit during severe weather conditions. If possible, remove the product from the window before such occurrences.

1.2 Pre-Installation and Installation

 **WARNING**

- Use this unit only on a dedicated circuit.
- Damage to the installation area could cause the unit to fall, potentially resulting in personal injury, property damage, or product failure.
- Only qualified personnel should disassemble, install, remove, or repair the unit.
- Only a qualified electrician should perform electrical work. For more information, contact your dealer, seller, or an authorized service center.

 **CAUTION**

- While unpacking be careful of sharp edges around the unit as well as the edges of the fins on the condenser and evaporator.

1.3 Operation and Maintenance

 **WARNING**

- Do not use defective or under-rated circuit breakers.
- Ensure the unit is properly grounded and that a dedicated circuit and breaker are installed.
- Do not modify or extend the power cable. Ensure the power cable is secure and not damaged during operation.
- Do not unplug the power supply plug during operation.
- Do not store or use flammable materials near the unit.
- Do not open the inlet grill of the unit during operation.
- Do not touch the electrostatic filter if the unit is equipped with one.
- Do not block the inlet or outlet of air flow to the unit.
- Do not use harsh detergents, solvents, or similar items to clean the unit. Use a soft cloth for cleaning.
- Do not touch the metal parts of the unit when removing the air filter as they are very sharp.
- Do not step on or place anything on the unit or outdoor units.
- Do not drink water drained from the unit
- Avoid direct skin contact with water drained from the unit.
- Use a firm stool or step ladder according to manufacturer procedures when cleaning or maintaining the unit.

 **CAUTION**

- Do not install or operate the unit for an extended period of time in areas of high humidity or in an environment directly exposing it to sea wind or salt spray.
- Do not install the unit on a defective or damaged installation stand, or in an unsecure location.
- Ensure the unit is installed at a level position
- Do not install the unit where noise or air discharge created by the outdoor unit will negatively impact the environment or nearby residences.
- Do not expose skin directly to the air discharged by the unit for prolonged periods of time.
- Ensure the unit do not operate in areas water or other liquids.
- Ensure the drain hose is installed correctly to ensure proper water drainage.
- When lifting or transporting the unit, it is recommended that two or more people are used for this task.
- When the unit is not to be used for an extended time, disconnect the power supply or turn off the breaker.

2. Information servicing(For flammable materials)

2.1 Checks to the area

- Prior to beginning work on systems containing flammable refrigerants, safety checks are necessary to ensure that the risk of ignition is minimized. For repair to the refrigerating system, the following precautions shall be complied with prior to conducting work on the system.

2.2 Work procedure

- Works shall be undertaken under a controlled procedure so as to minimise the risk of a flammable gas or vapour being present while the work is being performed. Technical personnel in charge of operation, supervision, maintenance of air-conditioning systems shall be adequately instructed and competent with respect to their tasks. Works shall be undertaken with appropriate tools only (In case of uncertainty, please consult the manufacturer of the tools for use with flammable refrigerants)

2.3 General work area

- All maintenance staff and others working in the local area shall be instructed on the nature of work being carried out. work in confined spaces shall be avoided. The area around the work space shall be sectioned off. Ensure that the conditions within the area have been made safe by control of flammable material.

2.4 Checking for presence of refrigerant

- The area shall be checked with an appropriate refrigerant detector prior to and during work, to ensure the technician is aware of potentially flammable atmospheres. Ensure that the leak detection equipment being used is suitable for use with flammable refrigerants, i.e. no sparking, adequately sealed or intrinsically safe.

2.5 Presence of fire extinguisher

- If any hot work is to be conducted on the refrigeration equipment or any associated parts, appropriate fire extinguishing equipment shall be available to hand. Have a dry powder or CO2 fire extinguisher adjacent to the charging area.

2.6 No ignition sources

- No person carrying out work in relation to a refrigeration system which involves exposing any pipe work that contains or has contained flammable refrigerant shall use any sources of ignition in such a manner that it may lead to the risk of fire or explosion. All possible ignition sources, including cigarette smoking, should be kept sufficiently far away from the site of installation, repairing, removing and disposal, during which flammable refrigerant can possibly be released

to the surrounding space. Prior to work taking place, the area around the equipment is to be surveyed to make sure that there are no flammable hazards or ignition risks. NO SMOKING signs shall be displayed.

2.7 Ventilated area

- Ensure that the area is in the open or that it is adequately ventilated before breaking into the system or conducting any hot work. A degree of ventilation shall continue during the period that the work is carried out. The ventilation should safely disperse any released refrigerant and preferably expel it externally into the atmosphere.

2.8 Checks to the refrigeration equipment

- Where electrical components are being changed, they shall be fit for the purpose and to the correct specification. At all times the manufacturer's maintenance and service guidelines shall be followed. If in doubt consult the manufacturer's technical department for assistance. The following checks shall be applied to installations using flammable refrigerants:
 - the charge size is in accordance with the room size within which the refrigerant containing parts are installed;
 - the ventilation machinery and outlets are operating adequately and are not obstructed;
 - if an indirect refrigerating circuit is being used, the secondary circuit shall be checked for the presence of refrigerant; marking to the equipment continues to be visible and legible.
 - markings and signs that are illegible shall be corrected;
 - refrigeration pipe or components are installed in a position where they are unlikely to be exposed to any substance which may corrode refrigerant containing components, unless the components are constructed of materials which are inherently resistant to being corroded or are suitably protected against being so corroded.

2.9 Checks to electrical devices

- Repair and maintenance to electrical components shall include initial safety checks and component inspection procedures. If a fault exists that could compromise safety, then no electrical supply shall be connected to the circuit until it is satisfactorily dealt with. If the fault cannot be corrected immediately but it is necessary to continue operation, and adequate temporary solution shall be used. This shall be reported to the owner of the equipment so all parties are advised.

Initial safety checks shall include:

- that capacitors are discharged: this shall be done in a safe manner to avoid possibility of sparking
- that there no live electrical components and wiring are exposed while charging, recovering or purging the system;
- that there is continuity of earth bonding.

2.10 Repairs to sealed components

- During repairs to sealed components, all electrical supplies shall be disconnected from the equipment being worked upon prior to any removal of sealed covers, etc. If it is absolutely necessary to have an electrical supply to equipment during servicing, then a permanently operating form of leak detection shall be located at the most critical point to warn of a potentially hazardous situation.
- Particular attention shall be paid to the following to ensure that by working on electrical components, the casing is not altered in such a way that the level of protection is affected. This shall include damage to cables, excessive number of connections, terminals not made to original specification, damage to seals, incorrect fitting of glands, etc.
 - Ensure that apparatus is mounted securely.
 - Ensure that seals or sealing materials have not degraded such that they no longer serve the purpose of preventing the ingress of flammable atmospheres. Replacement parts shall be in accordance with the manufacturer's specifications.

NOTE: The use of silicon sealant may inhibit the effectiveness of some types of leak detection equipment. Intrinsically safe components do not have to be isolated prior to working on them.

2.11 Repair to intrinsically safe components

- Do not apply any permanent inductive or capacitance loads to the circuit without ensuring that this will not exceed the permissible voltage and current permitted for the equipment in use. Intrinsically safe components are the only types that can be worked on while live in the presence of a flammable atmosphere. The test apparatus shall be at the correct rating.
- Replace components only with parts specified by the manufacturer. Other parts may result in the ignition of refrigerant in the atmosphere from a leak.

2.12 Cabling

- Check that cabling will not be subject to wear, corrosion, excessive pressure, vibration, sharp edges or any other adverse environmental effects. The check

shall also take into account the effects of aging or continual vibration from sources such as compressors or fans.

2.13 Detection of flammable refrigerants

- Under no circumstances shall potential sources of ignition be used in the searching for or detection of refrigerant leaks. A halide torch (or any other detector using a naked flame) shall not be used.

2.14 Leak detection methods

- The following leak detection methods are deemed acceptable for systems containing flammable refrigerants. Electronic leak detectors shall be used to detect flammable refrigerants, but the sensitivity may not be adequate, or may need re-calibration. (Detection equipment shall be calibrated in a refrigerant-free area.) Ensure that the detector is not a potential source of ignition and is suitable for the refrigerant used. Leak detection equipment shall be set at a percentage of the LFL of the refrigerant and shall be calibrated to the refrigerant employed and the appropriate percentage of gas (25 % maximum) is confirmed. Leak detection fluids are suitable for use with most refrigerants but the use of detergents containing chlorine shall be avoided as the chlorine may react with the refrigerant and corrode the copper pipe-work.
 - If a leak is suspected, all naked flames shall be removed or extinguished.
 - If a leakage of refrigerant is found which requires brazing, all of the refrigerant shall be recovered from the system, or isolated (by means of shut off valves) in a part of the system remote from the leak. Oxygen free nitrogen (OFN) shall then be purged through the system both before and during the brazing process.

2.15 Removal and evacuation

- When breaking into the refrigerant circuit to make repairs or for any other purpose, conventional procedures shall be used. However, it is important that best practice is followed since flammability is a consideration.
- The following procedure shall be adhered to:
 - remove refrigerant;
 - purge the circuit with inert gas;
 - evacuate;
 - purge again with inert gas;
 - open the circuit by cutting or brazing.

- The refrigerant charge shall be recovered into the correct recovery cylinders. The system shall be flushed with OFN to render the unit safe. This process may need to be repeated several times. Compressed air or oxygen shall not be used for this task. Flushing shall be achieved by breaking the vacuum in the system with OFN and continuing to fill until the working pressure is achieved, then venting to atmosphere, and finally pulling down to a vacuum. This process shall be repeated until no refrigerant is within the system. When the final OFN charge is used, the system shall be vented down to atmospheric pressure to enable work to take place. This operation is absolutely vital if brazing operations on the pipe-work are to take place.
- Ensure that the outlet for the vacuum pump is not close to any ignition sources and there is ventilation available.

2.16 Charging procedures

- In addition to conventional charging procedures, the following requirements shall be followed:
 - Ensure that contamination of different refrigerants does not occur when using charging equipment. Hoses or lines shall be as short as possible to minimize the amount of refrigerant contained in them.
 - Cylinders shall be kept upright.
 - Ensure that the refrigeration system is earthed prior to charging the system with refrigerant.
 - Label the system when charging is complete (if not already).
 - Extreme care shall be taken not to overfill the refrigeration system.
 - Prior to recharging the system it shall be pressure tested with OFN. The system shall be leak tested on completion of charging but prior to commissioning. A follow up leak test shall be carried out prior to leaving the site.

2.17 Decommissioning

Before carrying out this procedure, it is essential that the technician is completely familiar with the equipment and all its detail. It is recommended good practice that all refrigerants are recovered safely. Prior to the task being carried out, an oil and refrigerant sample shall be taken.

In case analysis is required prior to re-use of reclaimed refrigerant. It is essential that electrical power is available before the task is commenced.

- Become familiar with the equipment and its operation.
- Isolate system electrically.

- Before attempting the procedure ensure that:
 - mechanical handling equipment is available, if required, for handling refrigerant cylinders;
 - all personal protective equipment is available and being used correctly;
 - the recovery process is supervised at all times by a competent person;
 - recovery equipment and cylinders conform to the appropriate standards.
- Pump down refrigerant system, if possible.
- If a vacuum is not possible, make a manifold so that refrigerant can be removed from various parts of the system.
- Make sure that cylinder is situated on the scales before recovery takes place.
- Start the recovery machine and operate in accordance with manufacturer's instructions.
- Do not overfill cylinders. (No more than 80 % volume liquid charge).
- Do not exceed the maximum working pressure of the cylinder, even temporarily.
- When the cylinders have been filled correctly and the process completed, make sure that the cylinders and the equipment are removed from site promptly and all isolation valves on the equipment are closed off.
- Recovered refrigerant shall not be charged into another refrigeration system unless it has been cleaned and checked.

2.18 Labelling

- Equipment shall be labelled stating that it has been de-commissioned and emptied of refrigerant. The label shall be dated and signed. Ensure that there are labels on the equipment stating the equipment contains flammable refrigerant.

2.19 Recovery

- When removing refrigerant from a system, either for servicing or decommissioning, it is recommended good practice that all refrigerants are removed safely.
- When transferring refrigerant into cylinders, ensure that only appropriate refrigerant recovery cylinders are employed. Ensure that the correct numbers of cylinders for holding the total system charge are available. All cylinders to be used are designated for the recovered refrigerant and labelled for that refrigerant (i.e. special cylinders for the recovery of refrigerant). Cylinders shall be complete with pressure relief valve and associated shut-off valves in good working order.

- Empty recovery cylinders are evacuated and, if possible, cooled before recovery occurs.
- The recovery equipment shall be in good working order with a set of instructions concerning the equipment that is at hand and shall be suitable for the recovery of flammable refrigerants. In addition, a set of calibrated weighing scales shall be available and in good working order.
- Hoses shall be complete with leak-free disconnect couplings and in good condition. Before using the recovery machine, check that it is in satisfactory working order, has been properly maintained and that any associated electrical components are sealed to prevent ignition in the event of a refrigerant release. Consult manufacturer if in doubt.
- The recovered refrigerant shall be returned to the refrigerant supplier in the correct recovery cylinder, and the relevant Waste Transfer Note arranged. Do not mix refrigerants in recovery units and especially not in cylinders.
- If compressors or compressor oils are to be removed, ensure that they have been evacuated to an acceptable level to make certain that flammable refrigerant does not remain within the lubricant. The evacuation process shall be carried out prior to returning the compressor to the suppliers. Only electric heating to the compressor body shall be employed to accelerate this process. When oil is drained from a system, it shall be carried out safely.

2.20 Venting of HC Refrigerant (R290)

Venting may be carried out as an alternative to recovering the refrigerant. Because HC refrigerants have no ODP and negligible GWP, under certain circumstances it may be considered acceptable to vent the refrigerant. However, if this is to be considered, it should be done in accordance with the relevant national rules or regulations, if they permit.

In particular, before venting a system, it would be necessary to:

- Ensure that legislation relating to waste material has been considered
- Ensure that environmental legislation has been considered
- Ensure that legislation addressing safety of hazardous substances is satisfied
- Venting is only carried out with systems that contain a small quantity of refrigerant, typically less than 500 g.
- Venting to inside a building is not permissible under any circumstances
- Venting must not be to a public area, or where people

are unaware of the procedure taking place

- The hose must be of sufficient length and diameter such that it will extend to at least 3 m beyond the outside of the building
- The venting should only take place on the certainty that the refrigerant will not get blown back into any adjacent buildings, and that it will not migrate to a location below ground level
- The hose is made of material that is compatible for use with HC refrigerants and oil
- A device is used to raise the hose discharge at least 1 m above ground level and so that the discharge is pointed in an upwards direction (to assist with dilution)
- The end of the hose can now discharge and disperse the flammable fumes into the ambient air.
- There should not be any restriction or sharp bends within the vent-line which will hinder the ease of flow.
- There must be no sources of ignition near the hose discharge
- The hose should be regularly checked to ensure that there are no holes or kinks in it, that could lead to leakage or blocking of the passage of flow

When carrying out the venting, the flow of refrigerant should be metered using manifold gauges to a low flow rate, so as to ensure the refrigerant is well diluted. Once the refrigerant has ceased flowing, if possible, the system should be flushed out with OFN; if not, then the system should be pressurised with OFN and the venting procedure carried out two or more times, to ensure that there is minimal HC refrigerant remaining inside the system.

Specifications

Contents

1.	Model Reference.....	2
2.	Pipe Length and Drop Height.....	3
3.	Refrigerant Cycle Diagrams	4
4.	Electrical Wiring Diagrams.....	5

1. Model Reference

Refer to the following table to determine the specific indoor and outdoor unit model.

Indoor Unit Model	Outdoor Unit Model	Capacity (Btu/h)	Power Supply
CAC12CA(I)	CAC12CA(O)	12k	115V~, 60Hz, 1Phase
CAC12CD(I)	CAC12CD(O)		
CAC18CD(I)	CAC18CD(O)	18k	220-230V~, 60Hz, 1Phase
CAC24CD(I)	CAC24CD(O)	22k	

2. Pipe Length and Drop Height

The length and elevation of connection pipe are shown in the table below. If the pipe length exceeds max pipe length, additional refrigerant should be charged to ensure nominal cooling/heating capacity.

Capacity(Btu/h)	Standard Length	Max Pipe Length	Max Elevation	Additional Refrigerant
12k	7.5m (24.6ft)	25m (82.0ft)	10m (32.8ft)	12g/m (0.13oz/ft)
18k		30m(98.4ft)	20m(65.6ft)	
22k				

If oil flows back into the outdoor unit's compressor, this might cause liquid compression or deterioration of oil return. Oil traps in the rising gas pipe can prevent this.

-An oil trap should be installed every 6m(20ft) of vertical suction line riser.

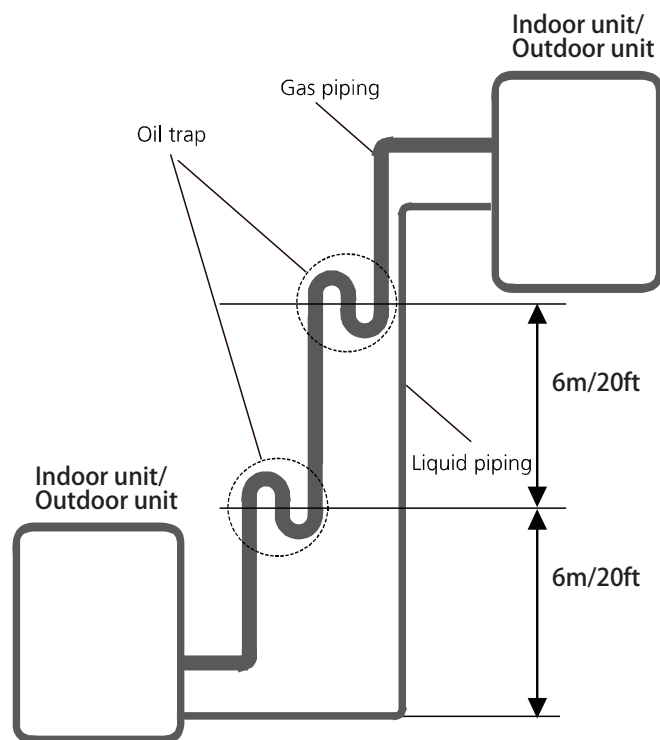

3. Refrigerant Cycle Diagrams

CAC12CA(I), CAC12CD(I)

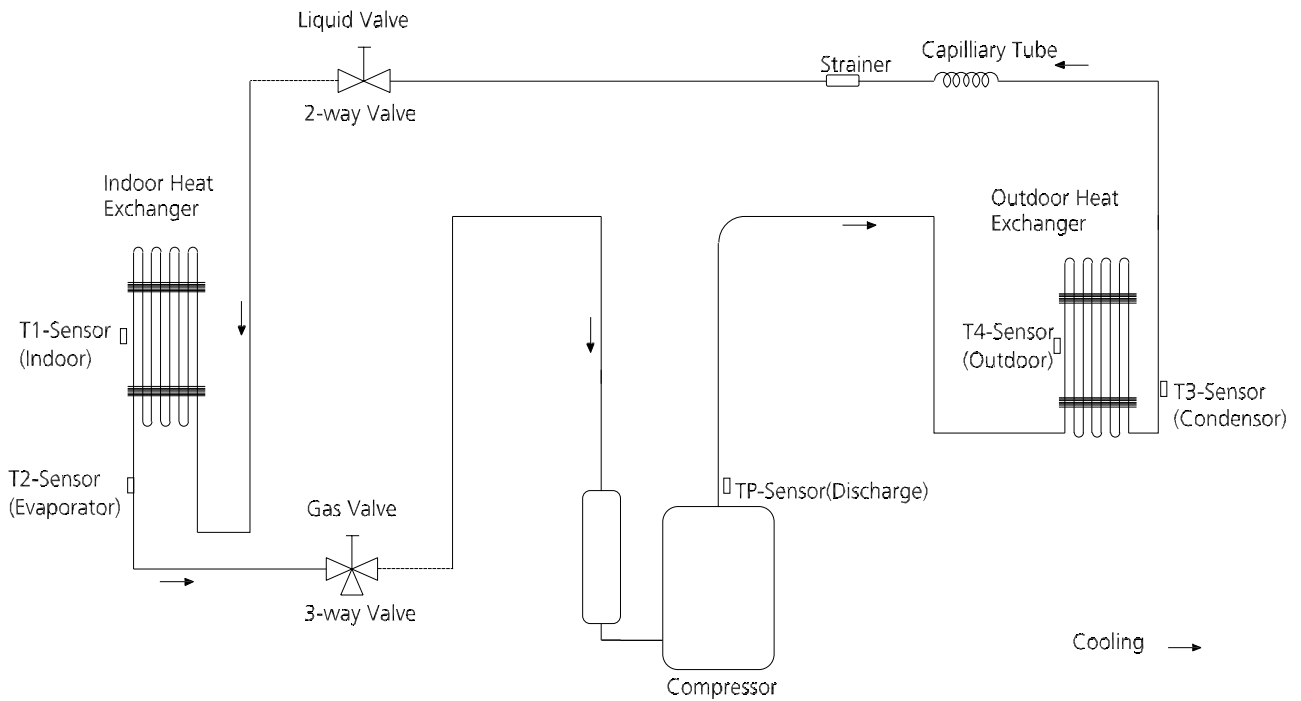

CAC18CD(I), CAC24CD(I)

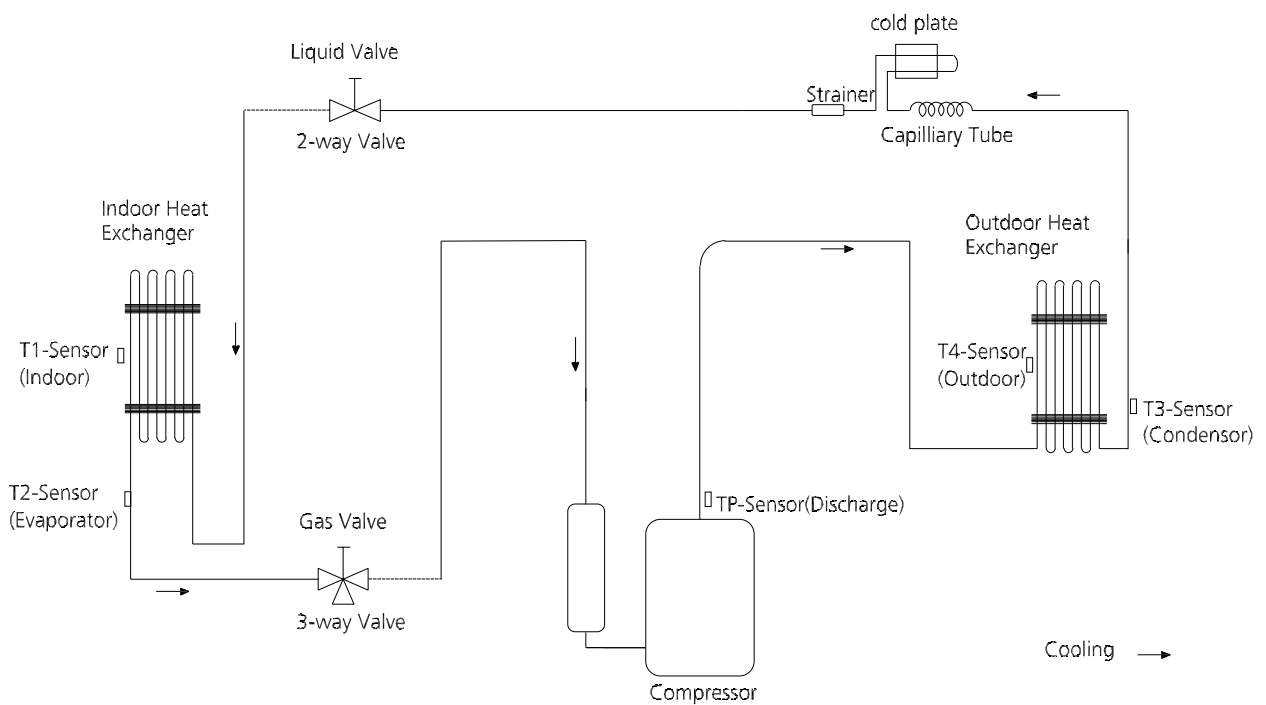

4. Electrical Wiring Diagrams

Indoor and outdoor unit wiring diagram

Indoor Unit		Outdoor Unit	
IDU Model	IDU Wiring Diagram	ODU Model	ODU Wiring Diagram
CAC12CA(I)	16022000020361	CAC12CA(O)	16022000031649
CAC12CD(I)	16022000020361	CAC12CD(O)	16022000019673
CAC18CD(I)	16022000020361	CAC18CD(O)	16022000019673
CAC24CD(I)	16022000019694	CAC24CD(O)	16022000019673

Outdoor unit printed circuit board diagram

Outdoor Unit	
ODU Model	ODU Printed Circuit Board
CAC12CA(O)	17122000062141
CAC12CD(O)	17122000061817
CAC18CD(O)	17122000062193
CAC24CD(O)	17122000059778

Indoor unit abbreviations

Abbreviation	Paraphrase
Y/G	Yellow-Green Conductor
ION	Positive and Negative Ion Generator
CAP	Capacitor
PLASMA	Electronic Dust Collector
L	LIVE
N	NEUTRAL

Outdoor unit abbreviations

Abbreviation	Paraphrase
DC FAN	Direct Current Fan
AC FAN	Alternate Current Fan

Indoor unit wiring diagram: 16022000020361

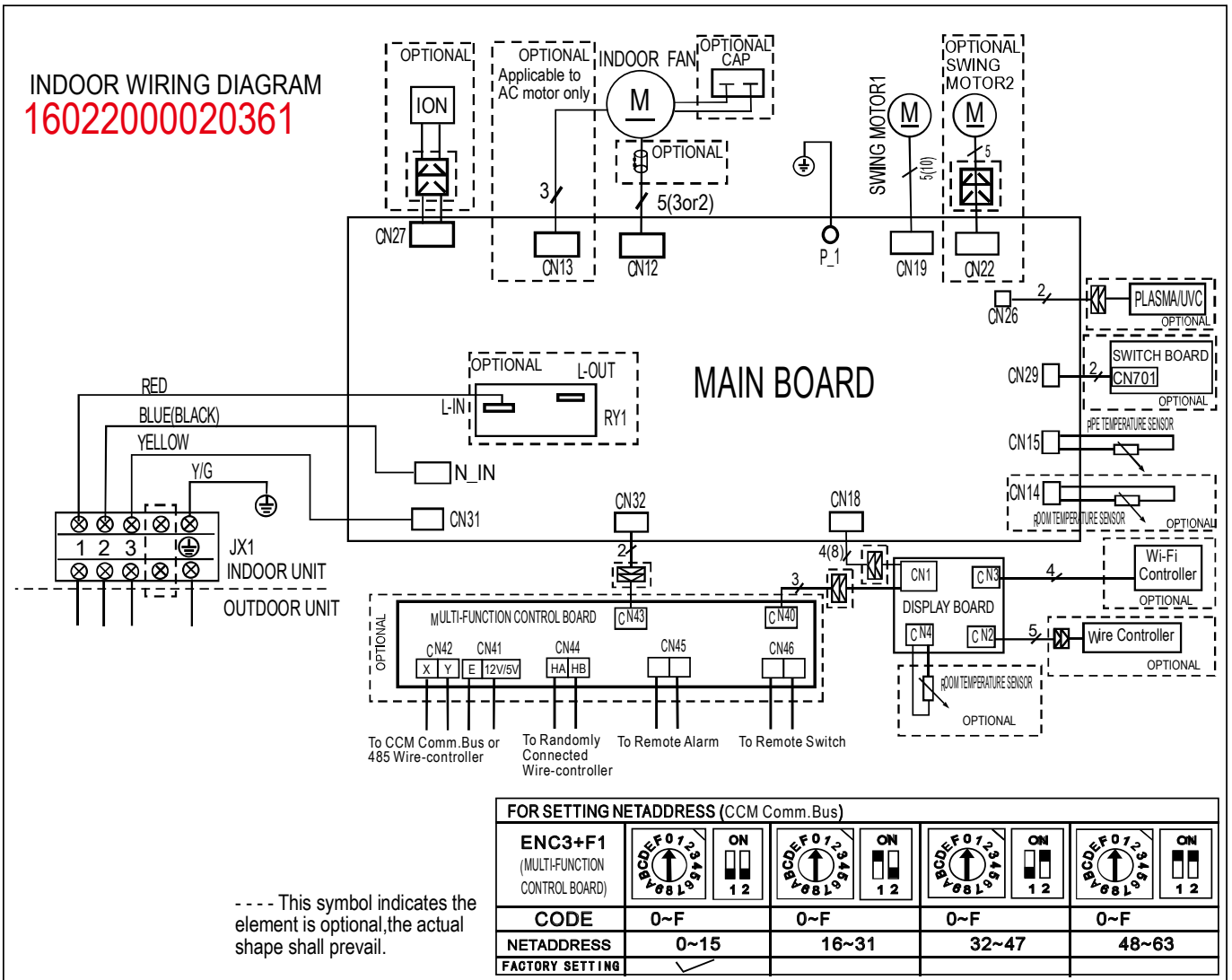

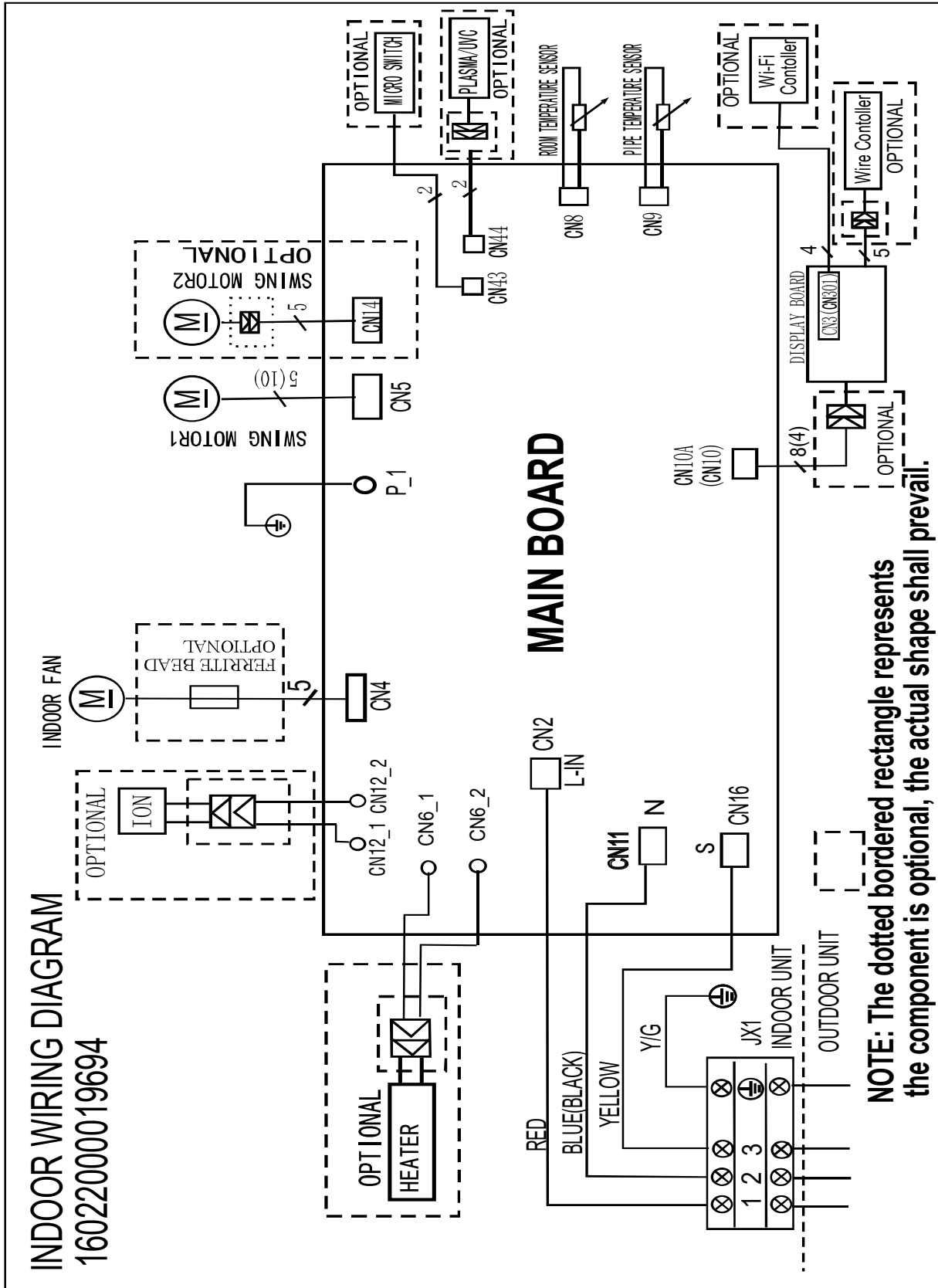

Outdoor unit wiring diagram: 16022000031649

16022000031649

NOTE: the connection wires for reactor and capacitor should be in the same colors, black or brown

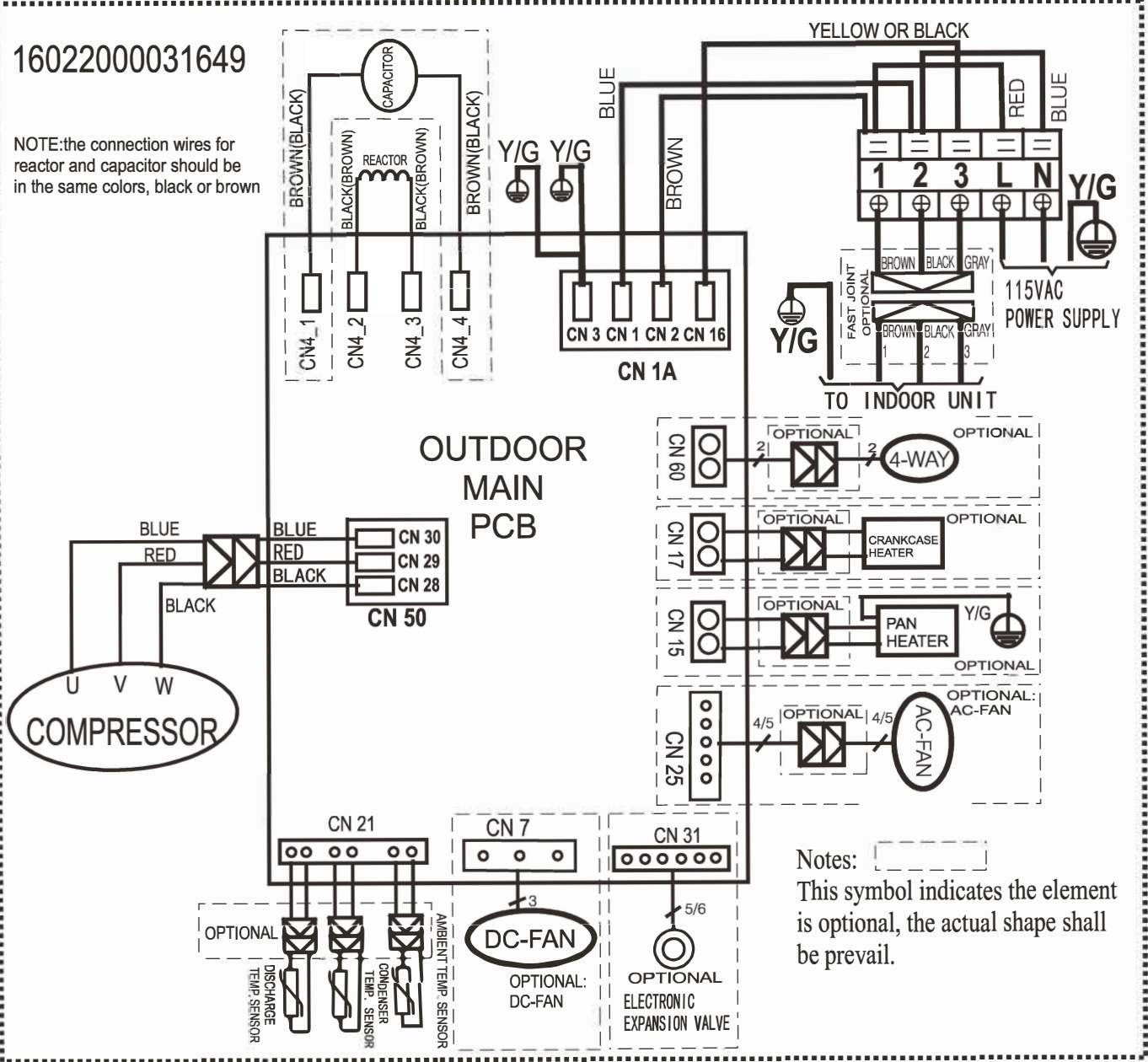

Notes:
 This symbol indicates the element is optional, the actual shape shall be prevail.

Notes:

This symbol indicates the element is optional, the actual shape shall prevail.

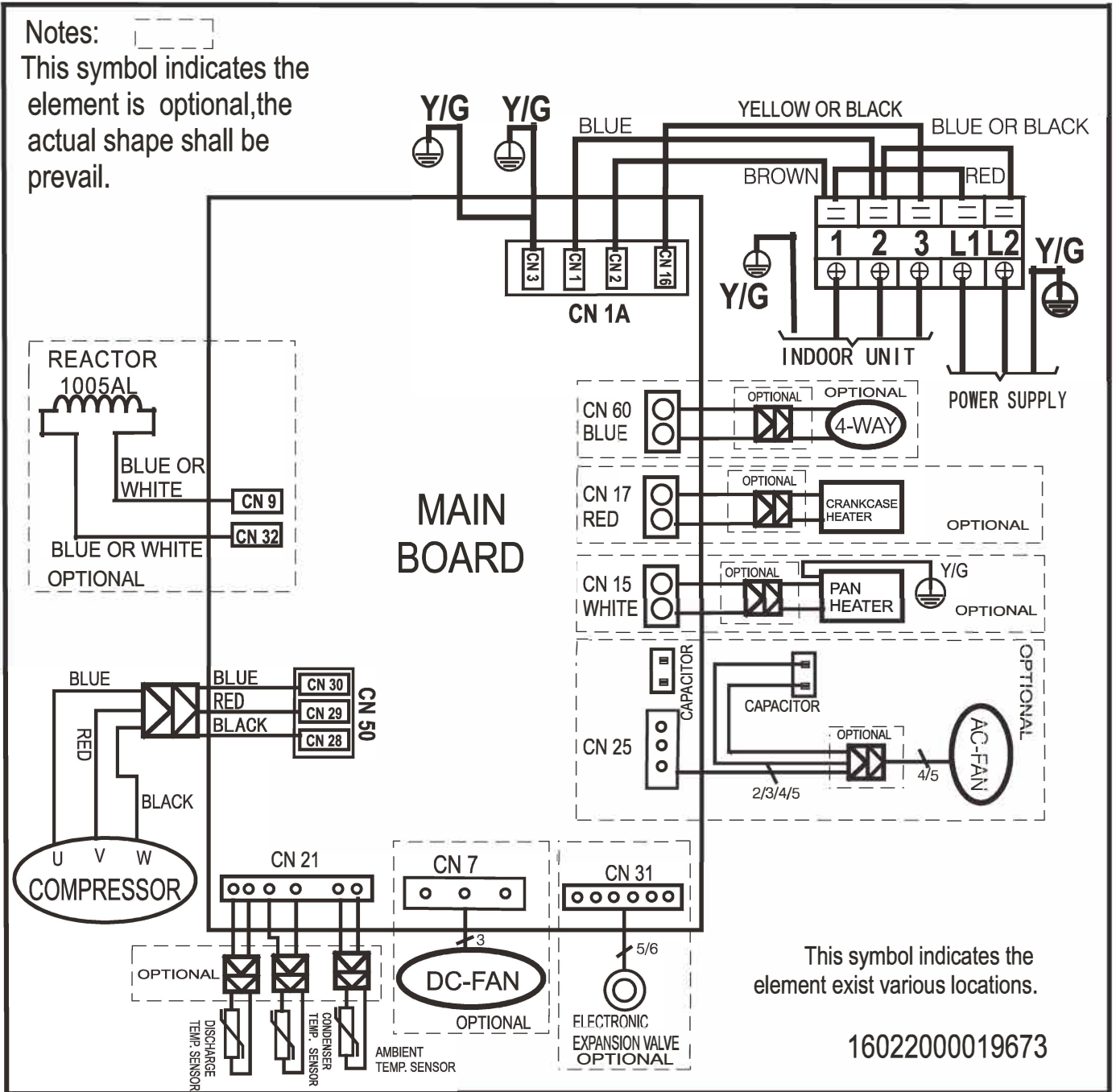

This symbol indicates the element exist various locations.

Outdoor unit printed circuit board diagram: 17122000062141

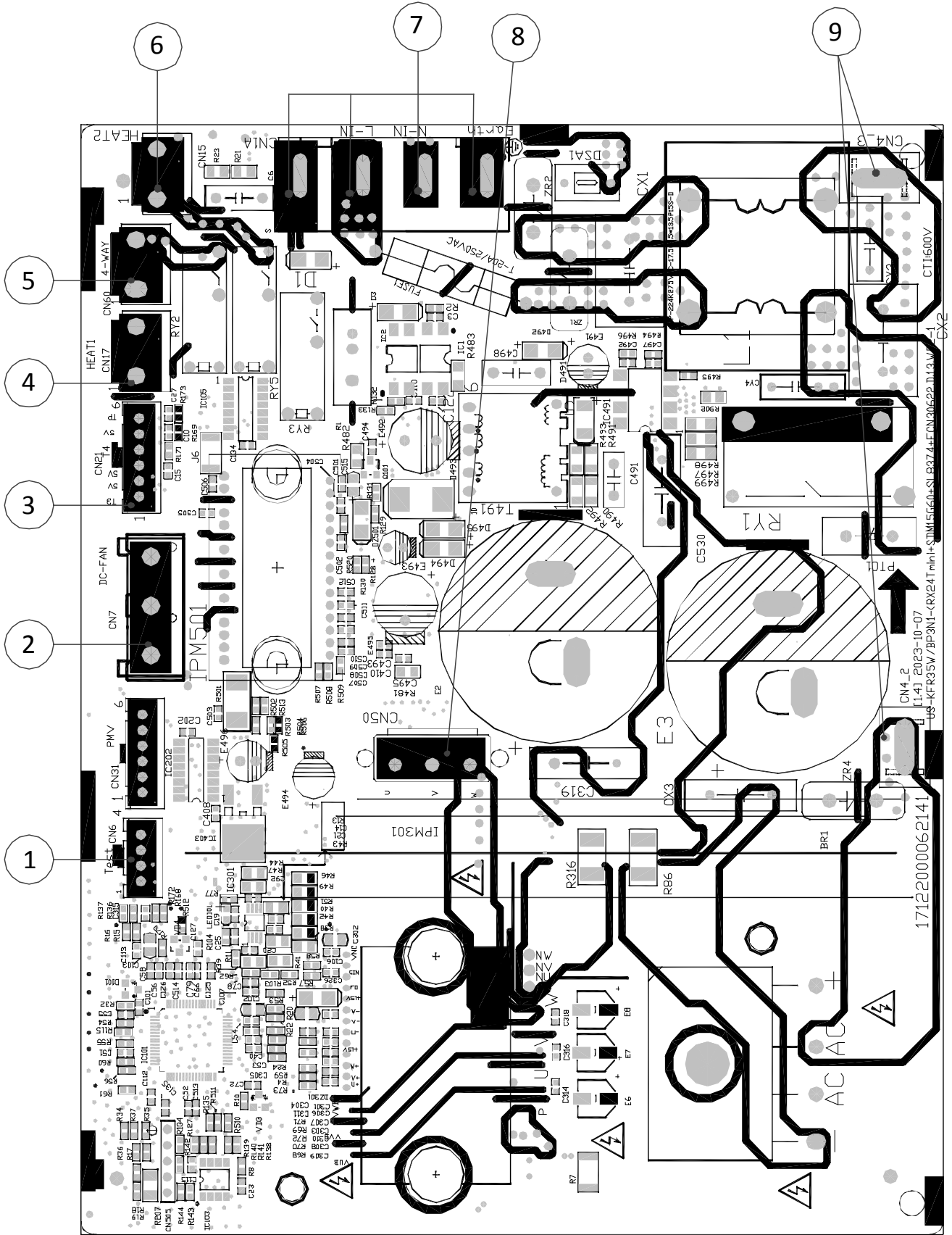

No.	Name	CN#	Meaning
1	TESTPORT	CN6	used for testing
2	DC-FAN	CN7	connect to DC fan
3	TP T4 T3	CN21	connect to pipe temp. sensor T3, ambient temp. sensor T4, exhaust temp. sensor TP
4	HEAT1	CN17	connect to compressor heater, 100-130V AC when is ON
5	4-WAY	CN60	connect to 4 way valve, 100-130V AC when is ON.
6	HEAT2	CN15	connect to chassis heater, 100-130V AC when is ON
7	CN1A	/	S: connect to indoor unit communication
		/	L_in: connect to L-line (100-130V AC input)
		/	N_in: connect to N-line (100-130V AC input)
		/	Earth
8	CN50	W	connect to compressor,0V AC (standby),0-310V AC (running)
		V	
		U	
9	REACTOR	CN4_2	connect to reactor, 100-130V AC when is ON
		CN4_3	

Note: This section is for reference only. Please take practicality as standard.

Outdoor unit printed circuit board diagram: 17122000061817

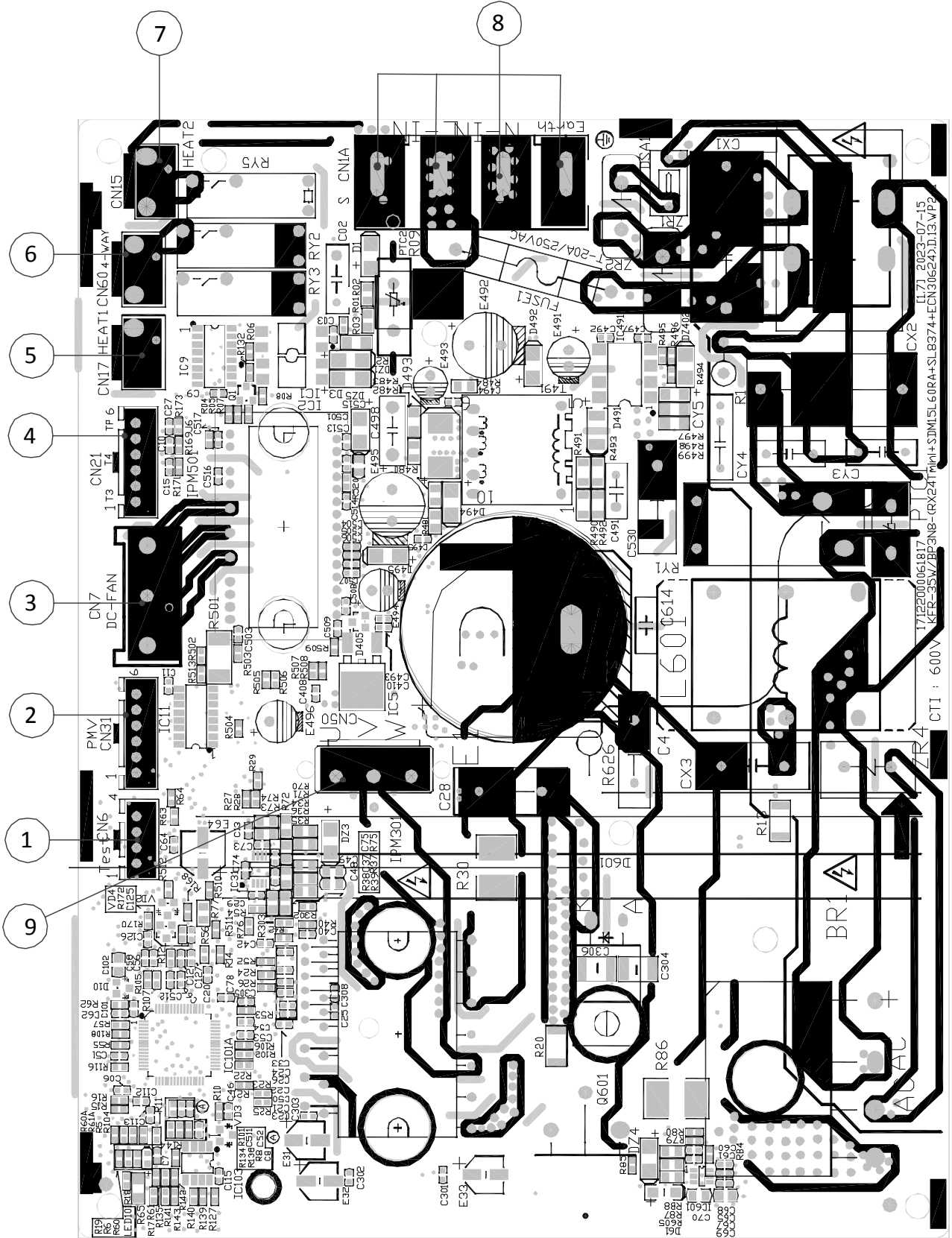

No.	Name	CN#	Meaning
1	TESTPORT	CN6	used for testing
2	PMV	CN31	connect to Electric Expansion Valve
3	DC-FAN	CN7	connect to DC fan
4	TP T4 T3	CN21	connect to pipe temp. sensor T3, ambient temp. sensor T4, exhaust temp. sensor TP
5	HEAT1	CN17	connect to compressor heater, 208-230V AC when is ON
6	4-WAY	CN60	connect to 4 way valve, 208-230V AC when is ON.
7	HEAT2	CN15	connect to chassis heater, 208-230V AC when is ON
8	CN1A	CN16	S: connect to indoor unit communication
		CN2	L_in: connect to L-line (208-230V AC input)
		CN1	N_in: connect to N-line (208-230V AC input)
		CN3	Earth
9	CN50	U	connect to compressor, 0V AC (standby),10-200V AC (running)
		V	
		W	

Note: This section is for reference only. Please take practicality as standard.

Outdoor unit printed circuit board diagram: 17122000062193

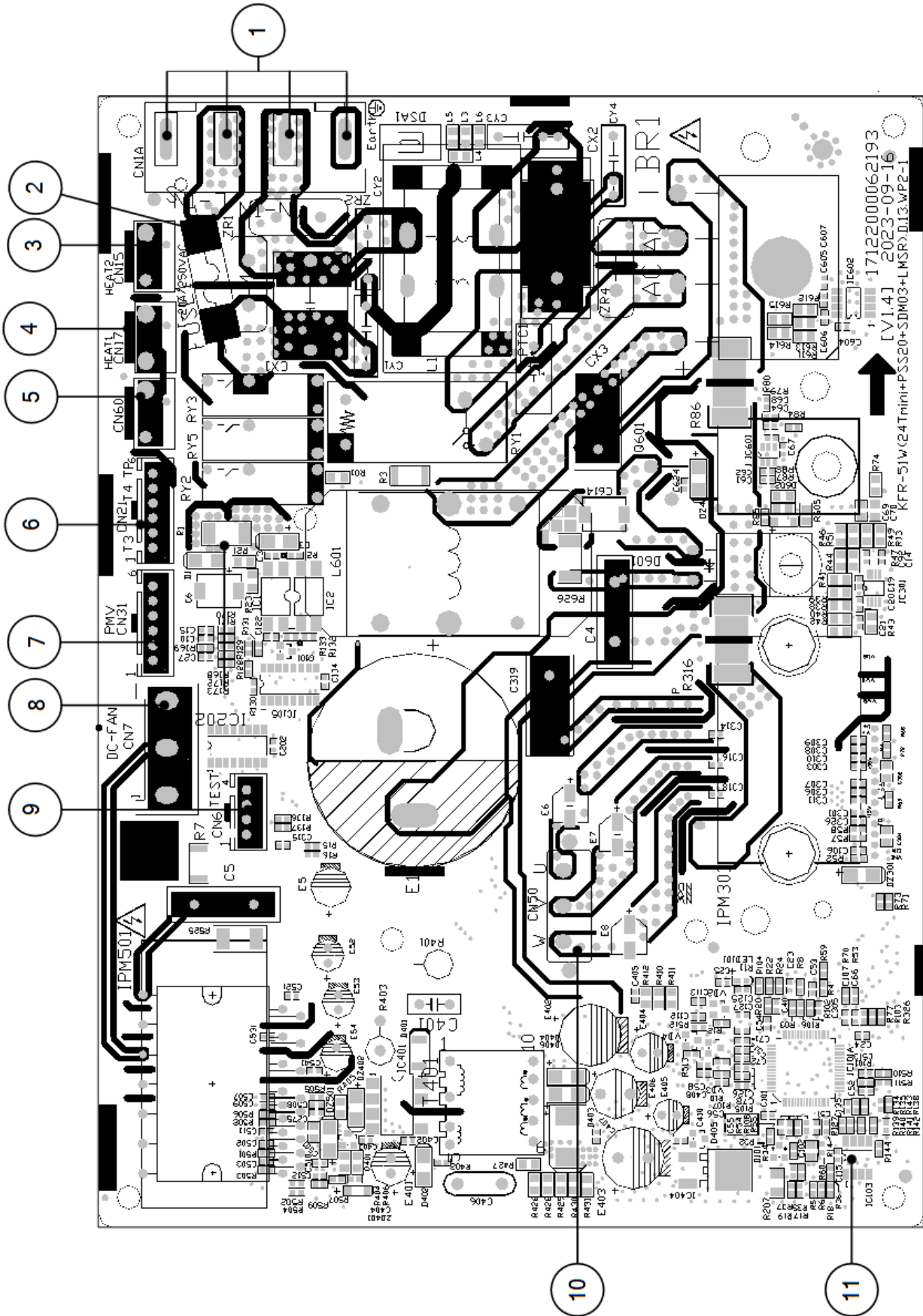

No.	Name	CN#	Meaning
1	Power Supply	CN1A	S: connect to indoor unit communication
			L_in: connect to L-line (208-240V AC input)
			N_in: connect to N-line (208-240V AC input)
			Earth: connect to Ground
2	FUSE	FUSE1	T-20A/250VAC
3	HEAT2	CN15	connect to chassis heater, 208-240V AC when is ON
4	HEAT1	CN17	connect to compressor heater, 208-240V AC when is ON
5	4-WAY	CN60	connect to 4 way valve, 208-240V AC when is ON.
6	TP T4 T3	CN21	connect to pipe temp. sensor T3, ambient temp. sensor T4, exhaust temp. sensor TP
7	PMV	CN31	connect to Electric Expansion Valve
8	DC-FAN	CN7	connect to DC fan
9	TESTPORT	CN6	used for testing
10	U	CN50	connect to compressor
	V		0V AC (standby)
	W		200-300V AC (running)
11	EE_PORT	IC103	EEPROM programmer port

Note: This section is for reference only. Please take practicality as standard.

Outdoor unit printed circuit board diagram: 17122000059778

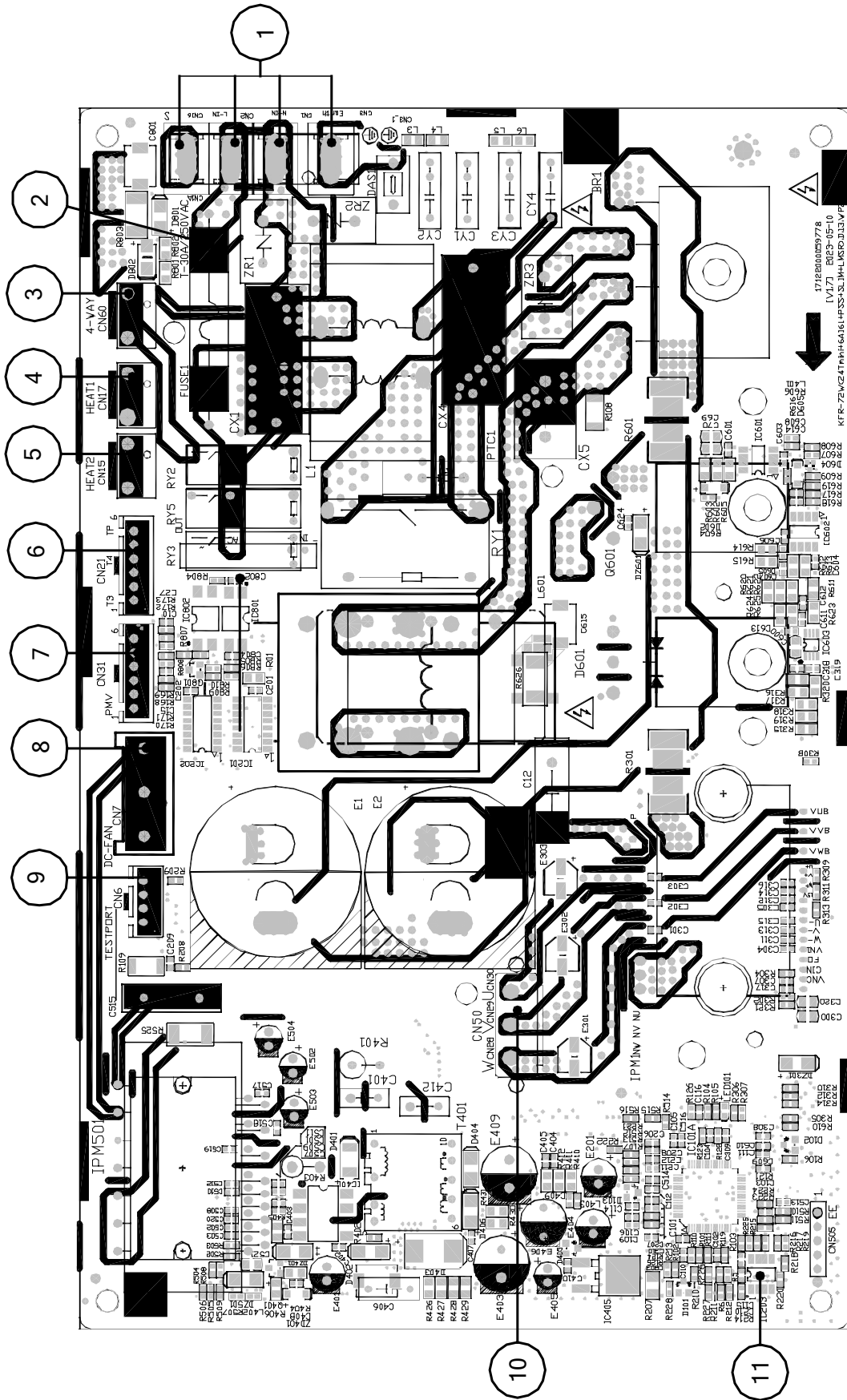

No.	Name	CN#	Meaning
1	Power Supply	/	S: connect to indoor unit communication
		/	L_in: connect to L-line (208-240V AC input)
		/	N_in: connect to N-line (208-240V AC input)
		/	Earth: connect to Ground
2	FUSE	FUSE1	T-30A/250VAC
3	4-WAY	CN60	connect to 4 way valve, 208-240V AC when is ON.
4	HEAT1	CN17	connect to compressor heater, 208-240V AC when is ON
5	HEAT2	CN15	connect to chassis heater, 208-240V AC when is ON
6	TP T4 T3	CN21	connect to pipe temp. sensor T3, ambient temp. sensor T4, exhaust temp. sensor TP
7	PMV	CN31	connect to Electric Expansion Valve
8	DC-FAN	CN7	connect to DC fan
9	TESTPORT	CN6	used for testing
10	U	CN50	connect to compressor,0V AC (standby),200-300V AC (running)
	V		
	W		
11	EE_PORT	IC203	EEPROM programer port

Note: This section is for reference only. Please take practicality as standard.

Product Features

Contents

1.	Display Function	2
2	Safety Features	3
3.	Basic Functions.....	4
3.1	Table	4
3.2	Abbreviation.....	5
3.3	Fan Mode.....	5
3.4	Cooling Mode	5
3.5	Heating Mode(Heat Pump Units)	6
3.6	Auto-mode.....	8
3.7	Drying Mode	8
3.8	Forced Operation Function	8
3.9	Timer Function	8
3.10	Sleep Function.....	9
3.11	Auto-Restart Function.....	9
3.12	Active Clean function	9
3.13	Follow me(Optional)	9
3.14	8°C Heating(Optional)	9
3.15	Silence (Optional)	9
3.16	ECO function(Optional)	9
3.17	Electrical energy consumption control function(Optional).....	10
3.18	Breeze away function(Optional)	10
3.19	Wireless control(optional)	10

1. Display Function





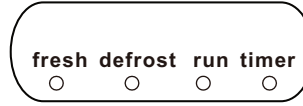

Unit display functions



Display A



Display B

Display		Function
fresh		Fresh(available on select units only)
defrost		Defrost
run		When the unit is on
timer		When TIMER is on
		WiFi control (available on select units only)
	Temperature value	Temperature
	 (3s)	Activation of Timer ON, Fresh, Swing, Turbo, or Silent
	 (3s)	Cancellation of Timer OFF, Fresh, Swing, Turbo, or Silent
		Defrost
		Active Clean(For Inverter split type) or self-cleaning(For Fixed-speed type)
		Heating in room temperature under 8°C

Note: Please select the display function according to your purchase product.

2. Safety Features

Compressor three-minute delay at restart

Compressor functions are delayed for up to ten seconds upon the first startup of the unit, and are delayed for up to three minutes upon subsequent unit restarts.

Automatic shutoff based on discharge temperature

If the compressor discharge temperature exceeds a certain level for a period of time, the compressor ceases operation.

Automatic shutoff based on fan speed

If the indoor fan speed registers below 200RPM or over 2100RPM for an extended period of time, the unit ceases operation and the corresponding error code is displayed on the indoor unit.

Inverter module protection

The inverter module has an automatic shutoff mechanism based on the unit's current, voltage, and temperature. If automatic shutoff is initiated, the corresponding error code is displayed on the indoor unit and the unit ceases operation.

Indoor fan delayed operation

- When the unit starts, the louver is automatically activated and the indoor fan will operate after a period of setting time or the louver is in place.
- If the unit is in heating mode, the indoor fan is regulated by the anti-cold wind function.

Compressor preheating

Preheating is automatically activated when T4 sensor is lower than setting temperature.

Sensor redundancy and automatic shutoff

- If one temperature sensor malfunctions, the air conditioner continues operation and displays the corresponding error code, allowing for emergency use.
- When more than one temperature sensor is malfunctioning, the air conditioner ceases operation.

3. Basic Functions

3.1 Table

Functions		Heating Mode	
		Defrosting Mode	
Cases		Case 1	Case 2
Models	12k~22k	NA	NA

Note: The detailed description of case 1 or case 2 is shown in the following function section(3.5).

3.2 Abbreviation

Unit element abbreviations

Abbreviation	Element
T1	Indoor room temperature
T2	Coil temperature of evaporator
T3	Coil temperature of condenser
T4	Outdoor ambient temperature
Tsc	Adjusted setting temperature
TP	Compressor discharge temperature
CDIFTEMP	Cooling shutdown temperature
HDIFTEMP2	Heating shutdown temperature
TCDI1	Enter defrost temperature
TCDE1	Exit defrost temperature1
TCDE2	Exit defrost temperature2 (maintain for a period of time)
TIMING_DEFROST_TIME	Enter defrost time

In this manual, such as CDIFTEMP, HDIFTEMP2, TCDE1, TCDE2, TIMING_DEFROST_TIME...etc., they are well-setting parameter of EEPROM.

3.3 Fan Mode

When fan mode is activated:

- The outdoor fan and compressor cease operation.
- Temperature control is disabled and indoor room temperature is displayed.
- The indoor fan speed can be set to 1%~100%, or auto.
- The lower operations are identical to those in cooling mode.
- Auto fan: In fan-only mode, AC operates the same as auto fan in cooling mode with the temperature set at 24°C(75°F).(Tsc =24°C(75°F))

3.4 Cooling Mode

3.4.1 Compressor Control

Reach the configured temperature:

- 1) When the compressor runs continuously for within 120 minutes.
 - If the following conditions are satisfied, the compressor ceases operation.
 - Calculated frequency(fb) is less than minimum limit frequency(FminC).

- Compressor runs at FminC more than 10 minutes
- T1 is lower than or equal to (Tsc-CDIFTEMP-0.5°C(32.9°F))

Note: CDIFTEMP is EEPROM setting parameter. It is 2°C(35.6°F) usually.

- 2) When the compressor runs continuously for more than 120 minutes.

- If the following conditions are satisfied, the compressor ceases operation.
 - Calculated frequency(fb) is less than minimum limit frequency(FminC).
 - Compressor runs at FminC more than 10 minutes.
 - T1 is lower than or equal to (Tsc-CDIFTEMP).

Note: CDIFTEMP is EEPROM setting parameter. It is 2°C(35.6°F) usually.

- 3) If one of the following conditions is satisfied, not judge protective time.

- Compressor running frequency(fr) is more than test frequency(TestFre).
- Compressor running frequency is equal to test frequency, T4 is more than 15°C(59°F) or T4 fault.
- Change setting temperature.
- Turbo or sleep function on/off
- Various frequency limit shutdown occurs.

3.4.2 Indoor Fan Control

- 1) In cooling mode, the indoor fan operates continuously. The fan speed can be set to 1%-100%, or auto.

- 2) Auto fan

For DC fan motor units:

- Descent curve
 - When T1-Tsc is lower than or equal to 3.5°C(6.3°F), fan speed reduces to 80%;
 - When T1-Tsc is lower than or equal to 1°C(1.8°F), fan speed reduces to 60%;
 - When T1-Tsc is lower than or equal to 0.5°C(0.9°F), fan speed reduces to 40%;
 - When T1-Tsc is lower than or equal to 0°C(0°F), fan speed reduces to 20%;
 - When T1-Tsc is lower than or equal to -0.5°C(-0.9°F), fan speed reduces to 1%.
- Rise curve
 - When T1-Tsc is higher than 0°C(0°F), fan speed increases to 20%;

- When T1-Tsc is higher than 0.5°C(0.9°F), fan speed increases to 40%;
- When T1-Tsc is higher than 1°C(1.8°F), fan speed increases to 60%;
- When T1-Tsc is higher than 1.5°C(2.7°F), fan speed increases to 80%;
- When T1-Tsc is higher than 4°C(7.2°F), fan speed increases to 100%.

For AC fan motor units:

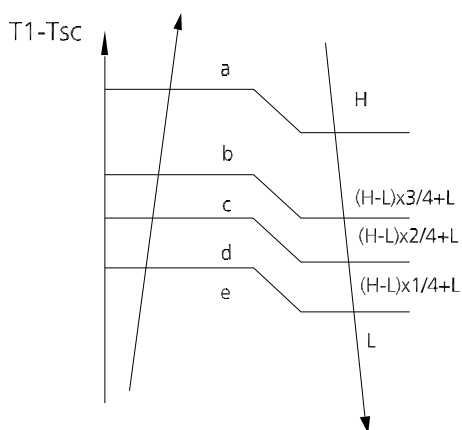

3.4.3 Outdoor Fan Control

- The outdoor unit will be run at different fan speed according to T4 and compressor running frequency.
- For different outdoor units, the fan speeds are different.

3.4.4 Condenser Temperature Protection

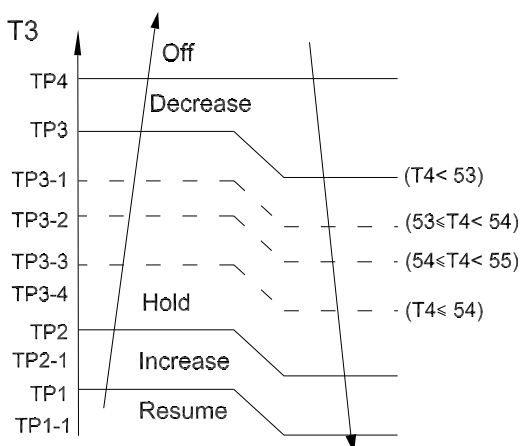

When the condenser temperature exceeds a configured value, the compressor ceases operation.

3.4.5 Evaporator Temperature Protection

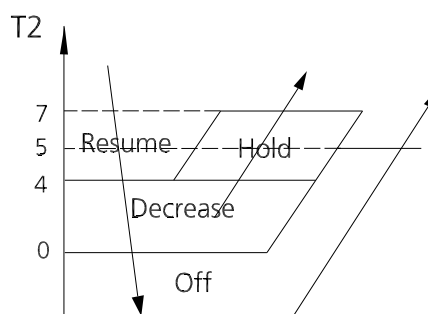

- Off: Compressor stops.
- Decrease: Decrease the running frequency to the lower level per 1 minute.
- Hold: Keep the current frequency.
- Resume: No limitation for frequency.

3.5 Heating Mode(Heat Pump Units)

3.5.1 Compressor Control

1) Reach the configured temperature

- If the following conditions are satisfied, the compressor ceases operation.
 - Calculated frequency(fb) is less than minimum limit frequency(FminH).
 - Compressor runs at FminH more than 10 minutes.
 - T1 is higher than or equal to Tsc+ HDIFTEMP2.

Note: HDIFTEMP2 is EEPROM setting parameter. It is 2°C(35.6°F) usually.

- If one of the following conditions is satisfied, not judge protective time.
 - Compressor running frequency(fr) is more than test frequency(TestFre).
 - When compressor running frequency is equal to test frequency, T4 is more than 15°C(59°F) or T4 fault.
 - Change setting temperature.
 - Turbo or sleep function on/off.

2) When the current is higher than the predefined safe value, surge protection is activated, causing the compressor to cease operations.

3.5.2 Indoor Fan Control:

1) In heating mode, the indoor fan operates continuously. The fan speed can be set to 1%-100%, or mute. And the anti-cold wind function has the priority.

- Anti-cold air function
 - The indoor fan is controlled by the indoor temperature T1 and indoor unit coil temperature T2.

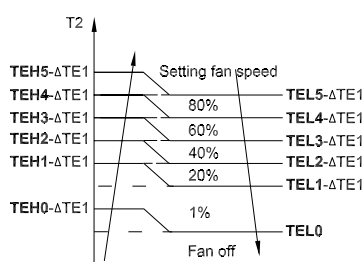

$T1 \geq 19^{\circ}\text{C} (66.2^{\circ}\text{F})$	$\Delta\text{TE1}=0$
$15^{\circ}\text{C} (59^{\circ}\text{F}) \leq T1 < 19^{\circ}\text{C} (66.2^{\circ}\text{F})$	$\Delta\text{TE1}=19^{\circ}\text{C}-T1$ ($34.2^{\circ}\text{F}-T1$)
$T1 < 15^{\circ}\text{C} (59^{\circ}\text{F})$	$\Delta\text{TE1}=4^{\circ}\text{C} (7.2^{\circ}\text{F})$

2) Auto fan

For DC fan motor units:

- Rise curve
 - When T1-Tsc is higher than $-1.5^{\circ}\text{C} (-2.7^{\circ}\text{F})$, fan speed reduces to 80%;
 - When T1-Tsc is higher than $0^{\circ}\text{C} (0^{\circ}\text{F})$, fan speed reduces to 60%;
 - When T1-Tsc is higher than $0.5^{\circ}\text{C} (0.9^{\circ}\text{F})$, fan speed reduces to 40%;
 - When T1-Tsc is higher than $1^{\circ}\text{C} (1.8^{\circ}\text{F})$, fan speed reduces to 20%.
- Descent curve
 - When T1-Tsc is lower than or equal to $0.5^{\circ}\text{C} (0.9^{\circ}\text{F})$, fan speed increases to 40%;
 - When T1-Tsc is lower than or equal to $0^{\circ}\text{C} (0^{\circ}\text{F})$, fan speed increases to 60%;
 - When T1-Tsc is lower than or equal to $-1.5^{\circ}\text{C} (-2.7^{\circ}\text{F})$, fan speed increases to 80%;
 - When T1-Tsc is lower than or equal to $-3^{\circ}\text{C} (5.4^{\circ}\text{F})$, fan speed increases to 100%.

For AC fan motor units:

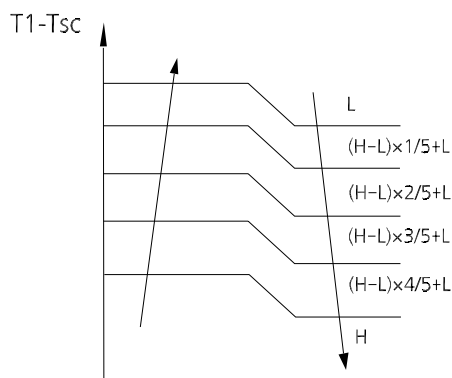

3.5.3 Outdoor Fan Control:

- The outdoor unit will be run at different fan speed according to T4 and compressor running frequency.

- For different outdoor units, the fan speeds are different.

3.5.4 Defrosting mode

- The unit enters defrosting mode according to changes in the temperature value of T3, T4 as well as the compressor running time.
- In defrosting mode, the compressor continues to run, the indoor and outdoor motor will cease operation, the defrost light of the indoor unit will turn on, and the "df" symbol is displayed.
- If any one of the following conditions is satisfied, defrosting ends and the machine switches to normal heating mode:
 - T3 rises above TCDE1°C.
 - T3 maintained above TCDE2°C for 80 seconds.
 - Unit runs for 15 minutes consecutively in defrosting mode.
- If T4 is lower than or equal to $-22^{\circ}\text{C} (-7.6^{\circ}\text{F})$ and compressor running time is more than TIMING_DEFROST_TIME, if any one of the following conditions is satisfied, defrosting ends and the machine switches to normal heating mode:
 - Unit runs for 10 minutes consecutively in defrosting mode.
 - T3 rises above $10^{\circ}\text{C} (50^{\circ}\text{F})$.

The following two conditions apply only to certain models, see tabel in section 3.1 for details.

Case 1:

- If T3 is lower than 3°C and compressor running time is more than 120 minutes, at this time, if T3 is lower than $\text{TCDI1}+4^{\circ}\text{C} (39.2^{\circ}\text{F})$ for 3 minutes, the unit enters defrosting mode.
- If any one of the following conditions is satisfied, defrosting ends and the machine switches to normal heating mode:
 - T3 rises above $\text{TCDE1}+4^{\circ}\text{C}$.
 - T3 maintained above $\text{TCDE2}+4^{\circ}\text{C}$ for 80 seconds.
 - Unit runs for 15 minutes consecutively in defrosting mode.

Case 2:

- If any one of the following conditions is satisfied, the unit enters defrosting mode
 - If T3 or T4 is lower than $-3^{\circ}\text{C} (26.6^{\circ}\text{F})$ for 30 seconds, $\text{Ts}-\text{T1}$ is lower than 5°C and compressor running time is more than 90min.
 - If T3 or T4 is lower than $-3^{\circ}\text{C} (26.6^{\circ}\text{F})$ for 30 seconds and compressor running time is more than 120min.

- If any one of the following conditions is satisfied, defrosting ends and the machine switches to normal heating mode:
 - T3 rises above TCDE1+4°C.
 - T3 maintained above TCDE2+4°C for 80 seconds.
 - Unit runs for 15 minutes consecutively in defrosting mode.

3.5.5 Evaporator Temperature Protection

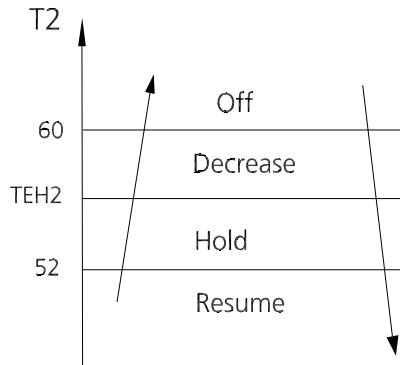

- Off: Compressor stops.
- Decrease: Decrease the running frequency to the lower level per 20 seconds.
- Hold: Keep the current frequency.
- Resume: No limitation for frequency.

3.6 Auto-mode

- This mode can be selected with the remote controller and the setting temperature can be changed between 16°C~30°C.
- In auto mode, the machine selects cooling, heating, auto-drying or fan-only mode on the basis of T1, Ts, T4 and relative humidity.

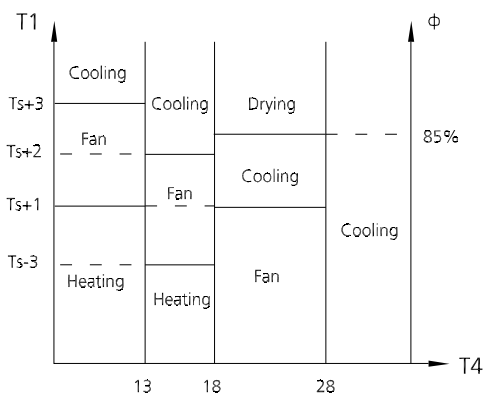

- If the setting temperature is modified, the machine selects a new running function.

3.7 Drying mode

- In drying mode, AC operates the same as auto fan in cooling mode.
- All protections are activated and operate the same as they do that in cooling mode.
- Low Room Temperature Protection

If the room temperature is lower than 10°C, the compressor ceases operations and does not resume until room temperature exceeds 12°C.

3.8 Forced operation function

- Forced cooling mode:

The compressor and outdoor fan continue to run (fixed at rated frequency), and the indoor fan runs at rated speed. After running for 30 minutes, the AC will switch to auto mode with a preset temperature of 24°C.

- Forced auto mode:

Forced auto mode operates the same as normal auto mode with a preset temperature of 24°C.

- The unit exits forced operation when it receives the following signals:

- Switch on
- Switch off
- Timer on
- Timer off
- Sleep mode
- Follow me
- Changes in:
 - mode
 - fan speed
 - setting temperature
- Forced defrosting mode:
 - Press AUTO/COOL button continuously for 5s under forced cooling mode to enter this mode.
 - Indoor fan will stop, defrosting lamp will light on.
 - Quit this mode and turn off the unit when:
 - quit normal defrosting
 - turn off by RC
 - Press AUTO/COOL button continuously for 5s again

3.9 Timer function

- Timing range is 24 hours.
- Timer on. The machine will turn on automatically

when reaching the setting time.

- Timer off. The machine will turn off automatically when reaching the setting time.
- Timer on/off. The machine will turn on automatically when reaching the setting "on" time, and then turn off automatically when reaching the setting "off" time.
- Timer off/on. The machine will turn off automatically when reaching the setting "off" time, and then turn on automatically when reaching the setting "on" time.
- The timer function will not change the AC current operation mode. Suppose AC is off now, it will not start up firstly after setting the "timer off" function. And when reaching the setting time, the timer LED will be off and the AC running mode has not been changed.
- The setting time is relative time.
- The AC will quit the timer function when it has malfunction

3.10 Sleep function

- The sleep function is available in cooling, heating, or auto mode.
- The operational process for sleep mode is as follows:
 - When cooling, the temperature rises 1°C (to not higher than 30°C) every hour. After 2 hours, the temperature stops rising and the indoor fan is fixed at low speed.
 - When heating, the temperature decreases 1°C (to not lower than 16°C) every hour. After 2 hours, the temperature stops decreasing and the indoor fan is fixed at low speed. Anti-cold wind function takes priority.
- The operating time for sleep mode is 8 hours, after which, the unit exits this mode.
- The timer setting is available in this mode.

3.11 Auto-Restart function

- The indoor unit has an auto-restart module that allows the unit to restart automatically. The module automatically stores the current settings and, in the case of a sudden power failure, will restore those setting automatically within 3 minutes after power returns.
- If there is a power failure while the unit is running, the compressor starts 3 minutes after the unit restarts. If the unit was already off before the power failure, the unit stands by.

3.12 Active Clean function

- The Active Clean Technology washes away dust, mold, and grease that may cause odors when it adheres to the heat exchanger by automatically freezing and then rapidly thawing the frost. The internal wind wheel then keeps operating to blow-dry the evaporator, thus preventing the growth of mold and keeping the inside clean.
- When this function is turned on, the indoor unit display window appears "CL", after 20 to 130 minutes, the unit will turn off automatically and cancel Active Clean function.

3.13 Follow me(Optional)

- If you press "Follow Me" on the remote, the indoor unit will beep. This indicates the follow me function is active.
- Once active, the remote control will send a signal every 3 minutes, with no beeps. The unit automatically sets the temperature according to the measurements from the remote control.
- The unit will only change modes if the information from the remote control makes it necessary, not from the unit's temperature setting.
- If the unit does not receive a signal for 7 minutes or you press "Follow Me," the function turns off. The unit regulates temperature based on its own sensor and settings.

3.14 8°C Heating(Optional)

In heating mode, the temperature can be set to as low as 8°C, preventing the indoor area from freezing if unoccupied during severe cold weather.

3.15 Silence (Optional)

Press "Silence" on the remote control to enable the SILENCE function. While this function is active, the indoor unit will run at faint breeze(1% fan speed), which reduces noise to the lowest possible level.

3.16 ECO function (Optional)

- Used to enter the energy efficient mode.
 - Under cooling mode, press ECO button, the remote controller will adjust the temperature automatically to 24°C, fan speed of Auto to save energy (but only if the set temperature is less than 24°C). If the set temperature is more than 24°C and 30°C, press the ECO button, the fan speed will change to Auto, the set temperature will remain unchanged.
- When AC receives signals, such as switch off, Turbo operation , Silence operation , Self clean operation

, Forced cooling operation, mode setting, Sleeping mode, or adjusting the set temperature to less than 24°C, it will quit the ECO operation.

- Operation time in ECO mode is 8 hours. After 8 hours the AC quits this mode.
- When there's any one temperature sensor in malfunction, the AC will quit ECO mode .
- Indoor fan will run at auto fan when enter into the ECO mode .The setting temperature and setting fan speed can be changed through remote controller signal.

3.17 Electrical energy consumption control function (Optional)

Press the "Gear" button on remote controller to enter the energy efficient mode in a sequence of following:

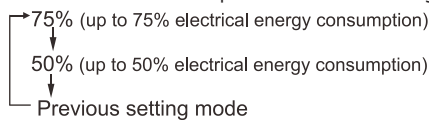

Turn off the unit or activate ECO, sleep, Super cool, 8°C Heating, Silence or self clean function will quit this function.

3.18 Breeze Away function (Optional)

- This feature avoids direct airflow blowing on the body and makes you feel indulging in silky coolness.
- NOTE: This feature is available under cooling mode, fan-only mode and drying mode.

3.19 Wireless Control (Optional)

- Wireless control allows you to control your air conditioner using your mobile phone and a Wireless connection.
- For the USB device access, replacement, maintenance operations must be carried out by professional staff.

Maintenance

Contents

1.	First Time Installation Check	2
2	Refrigerant Recharge	4
3	Re-Installation	5
3.1	Indoor Unit.....	5
3.2	Outdoor Unit.....	7

1. First Time Installation Check

Air and moisture trapped in the refrigerant system affects the performance of the air conditioner by:

- Increasing pressure in the system.
- Increasing the operating current.
- Decreasing the cooling or heating efficiency.
- Congesting the capillary tubing due to ice build-up in the refrigerant circuit.
- Corroding the refrigerant system.

To prevent air and moisture from affecting the air conditioner's performance, the indoor unit, as well as the pipes between the indoor and outdoor unit, must be leak tested and evacuated.

Leak test (soap water method)

Use a soft brush to apply soapy water or a neutral liquid detergent onto the indoor unit connections and outdoor unit connections. If there is gas leakage, bubbles will form on the connection.

Air purging with vacuum pump

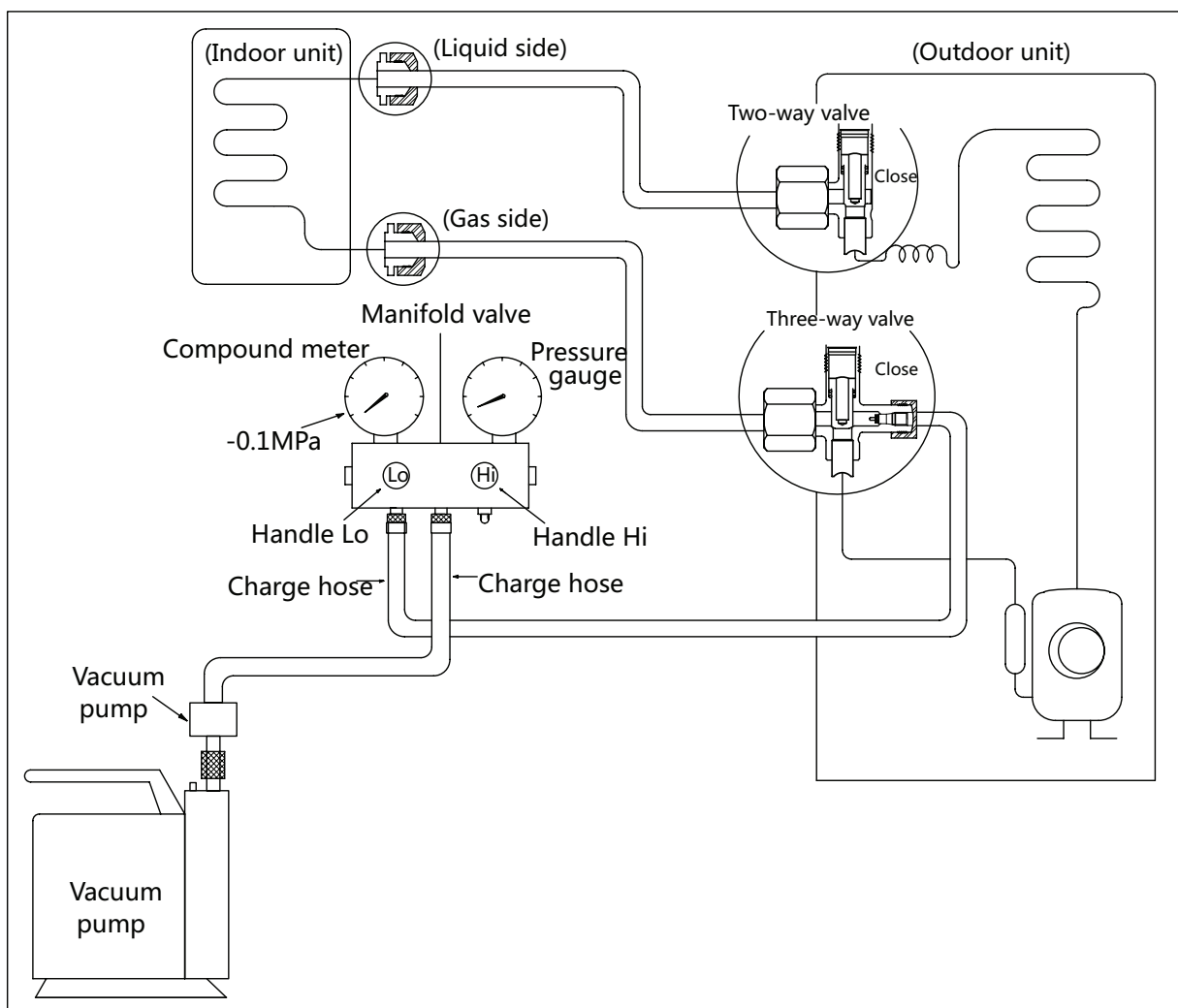

Procedure:

1. Tighten the flare nuts of the indoor and outdoor units, and confirm that both the 2- and 3-way valves are closed.
2. Connect the charge hose with the push pin of Handle Lo to the gas service port of the 3-way valve.
3. Connect another charge hose to the vacuum pump.
4. Fully open the Handle Lo manifold valve.
5. Using the vacuum pump, evacuate the system for 30 minutes.
 - a. Check whether the compound meter indicates -0.1 MPa (14.5 Psi).
 - If the meter does not indicate -0.1 MPa (14.5 Psi) after 30 minutes, continue evacuating for an additional 20 minutes.
 - If the pressure does not achieve -0.1 MPa (14.5 Psi) after 50 minutes, check for leakage.
6. Loosen the flare nut of the 3-way valve for 6 or 7 seconds and then tighten the flare nut again.
 - a. Confirm the pressure display in the pressure indicator is slightly higher than the atmospheric pressure.
 - b. Remove the charge hose from the 3-way valve.
7. Fully open the 2- and 3-way valves and tighten the cap of the 2- and 3-way valves.
 - If the pressure successfully reaches -0.1 MPa (14.5 Psi), fully close the Handle Lo valve, then cease vacuum pump operations.
8. Wait for 5 minutes then check whether the gauge needle moves after turning off the vacuum pump. If the gauge needle moves backward, check whether there is gas leakage.

2. Refrigerant Recharge

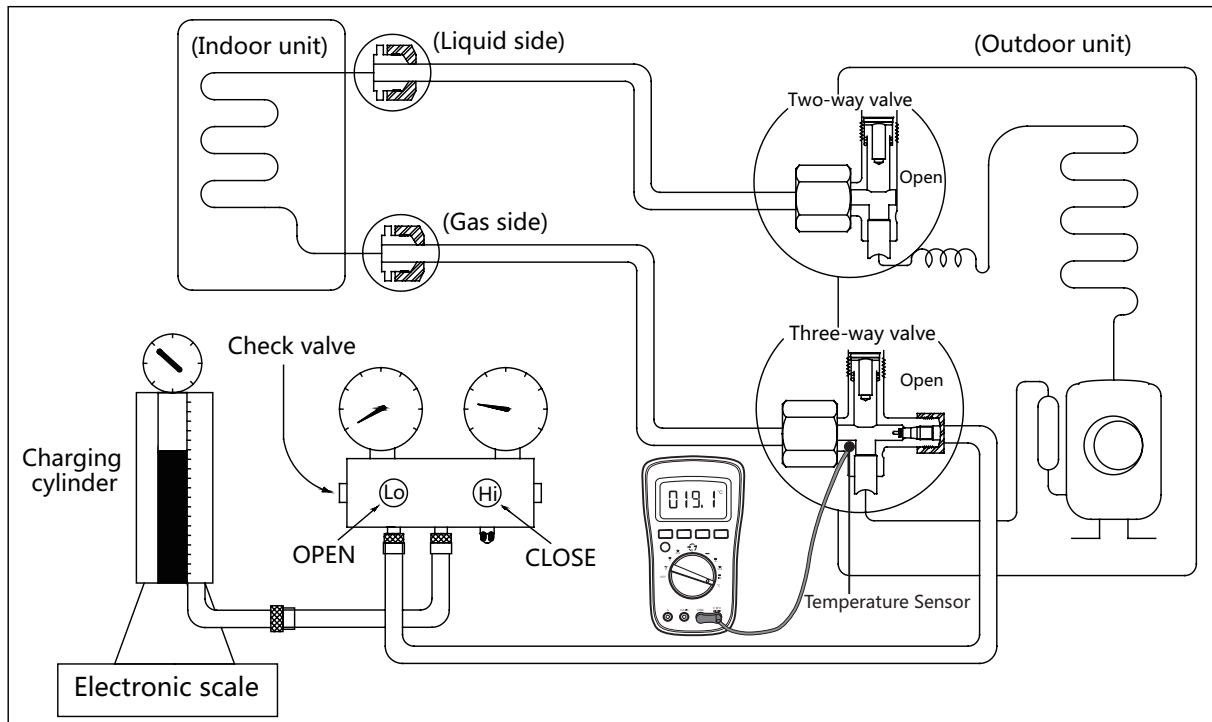

Procedure:

1. Close both 2- and 3-way valves.
2. Slightly connect the Handle Lo charge hose to the 3-way service port.
3. Connect the charge hose to the valve at the bottom of the cylinder.
4. If the refrigerant is R410A/R32, invert the cylinder to ensure a complete liquid charge.
5. Open the valve at the bottom of the cylinder for 5 seconds to purge the air in the charge hose, then fully tighten the charge hose with push pin Handle Lo to the service port of 3-way valve..
6. Place the charging cylinder onto an electronic scale and record the starting weight.
7. Fully open the Handle Lo manifold valve, 2- and 3-way valves.
8. Operate the air conditioner in cooling mode to charge the system with liquid refrigerant.
9. When the electronic scale displays the correct weight (refer to the gauge and the pressure of the low side to confirm, the value of pressure refers to chapter Appendix), turn off the air conditioner, then disconnect the charge hose from the 3-way service port immediately..
10. Mount the caps of service port and 2- and 3-way valves.
11. Use a torque wrench to tighten the caps to a torque of 18 N.m.
12. Check for gas leakage.

3. Re-Installation

3.1 Indoor Unit

Collecting the refrigerant into the outdoor unit

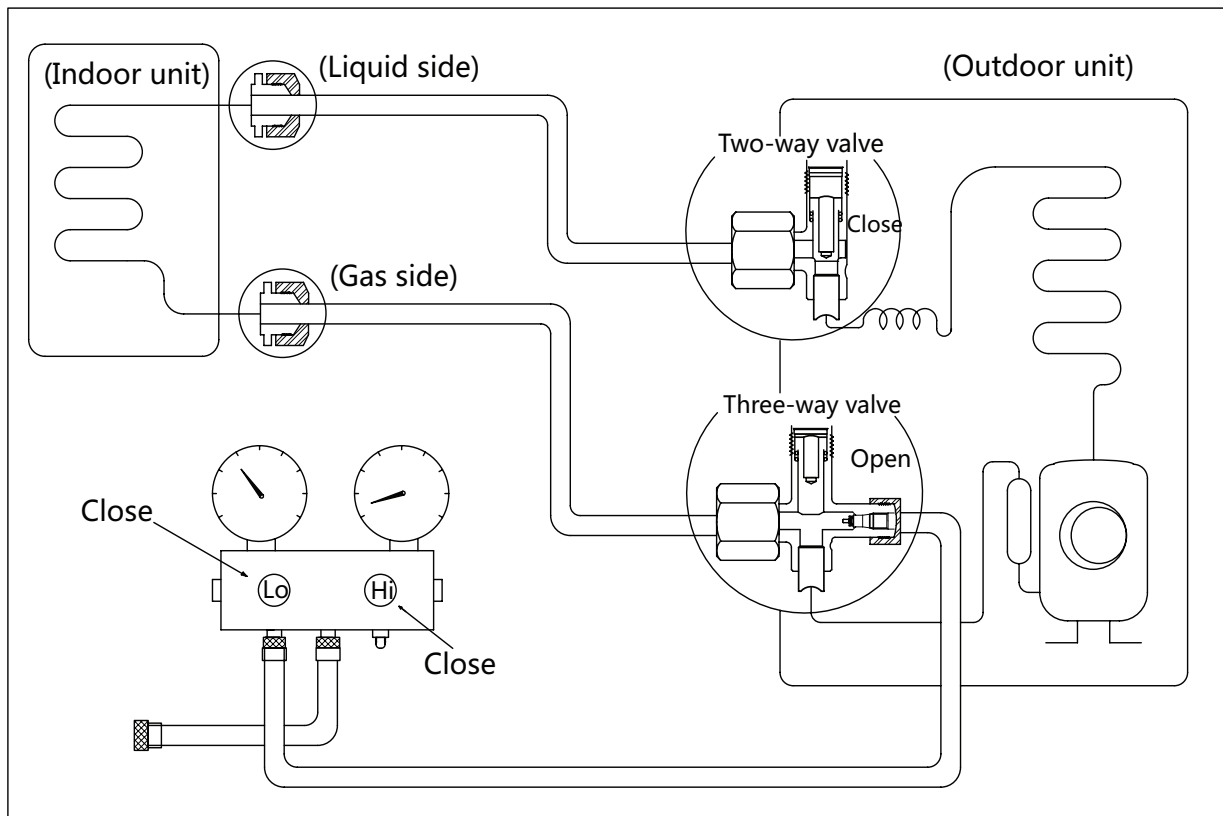

Procedure:

1. Confirm that the 2- and 3-way valves are opened.
2. Connect the charge hose with the push pin of Handle Lo to the 3-way valve's gas service port.
3. Open the Handle Lo manifold valve to purge air from the charge hose for 5 seconds and then close it quickly.
4. Close the 2-way valve.
5. Operate the air conditioner in cooling mode. Cease operations when the gauge reaches 0.1 MPa (14.5 Psi).
6. Close the 3-way valve so that the gauge rests between 0.3 MPa (43.5 Psi) and 0.5 MPa (72.5 Psi).
7. Disconnect the charge set and mount the caps of service port and 2- and 3-way valves.
8. Use a torque wrench to tighten the caps to a torque of 18 N.m.
9. Check for gas leakage.

Air purging with vacuum pump

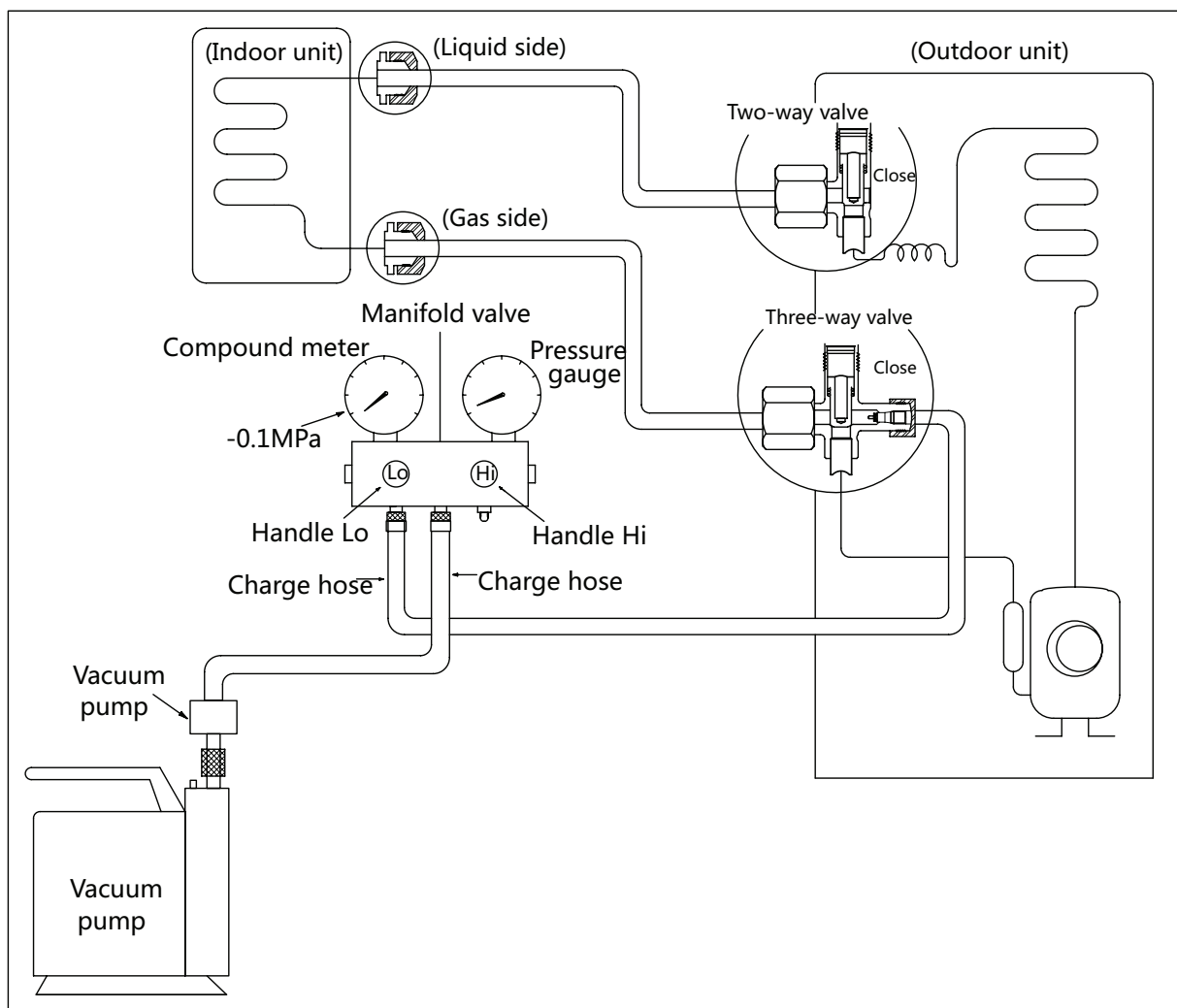

Procedure:

1. Tighten the flare nuts of the indoor and outdoor units, and confirm that both the 2- and 3-way valves are closed.
2. Connect the charge hose with the push pin of Handle Lo to the gas service port of the 3-way valve.
3. Connect another charge hose to the vacuum pump.
4. Fully open the Handle Lo manifold valve.
5. Using the vacuum pump, evacuate the system for 30 minutes.
 - a. Check whether the compound meter indicates -0.1 MPa (14.5 Psi).
 - If the meter does not indicate -0.1 MPa (14.5 Psi) after 30 minutes, continue evacuating for an additional 20 minutes.
 - If the pressure does not achieve -0.1 MPa (14.5 Psi) after 50 minutes, check for leakage.
 - b. If the pressure successfully reaches -0.1 MPa (14.5 Psi), fully close the Handle Lo valve, then cease vacuum pump operations.
6. Loosen the flare nut of the 3-way valve for 6 or 7 seconds and then tighten the flare nut again.
 - a. Confirm the pressure display in the pressure indicator is slightly higher than the atmospheric pressure.
 - b. Remove the charge hose from the 3-way valve.
7. Fully open the 2- and 3-way valves and tighten the cap of the 2- and 3-way valves.

3.2 Outdoor Unit

Evacuation for the whole system

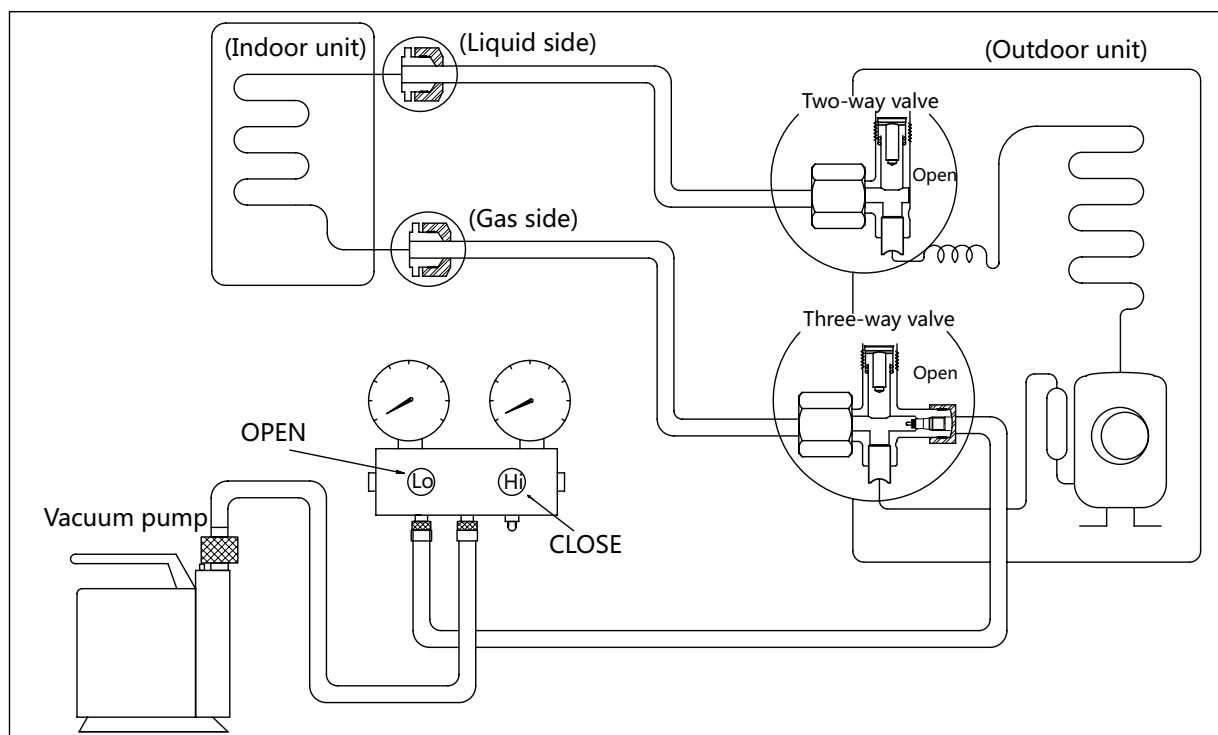

Procedure:

1. Confirm that the 2- and 3-way valves are opened.
2. Connect the vacuum pump to the 3-way valve's service port.
3. Evacuate the system for approximately one hour. Confirm that the compound meter indicates -0.1 MPa (14.5Psi).
4. Close the valve (Low side) on the charge set and turn off the vacuum pump.
5. Wait for 5 minutes then check whether the gauge needle moves after turning off the vacuum pump. If the gauge needle moves backward, check whether there is gas leakage.
6. Disconnect the charge hose from the vacuum pump.
7. Mount the caps of service port and 2- and 3-way valves.
8. Use a torque wrench to tighten the caps to a torque of 18 N.m.

Refrigerant charging

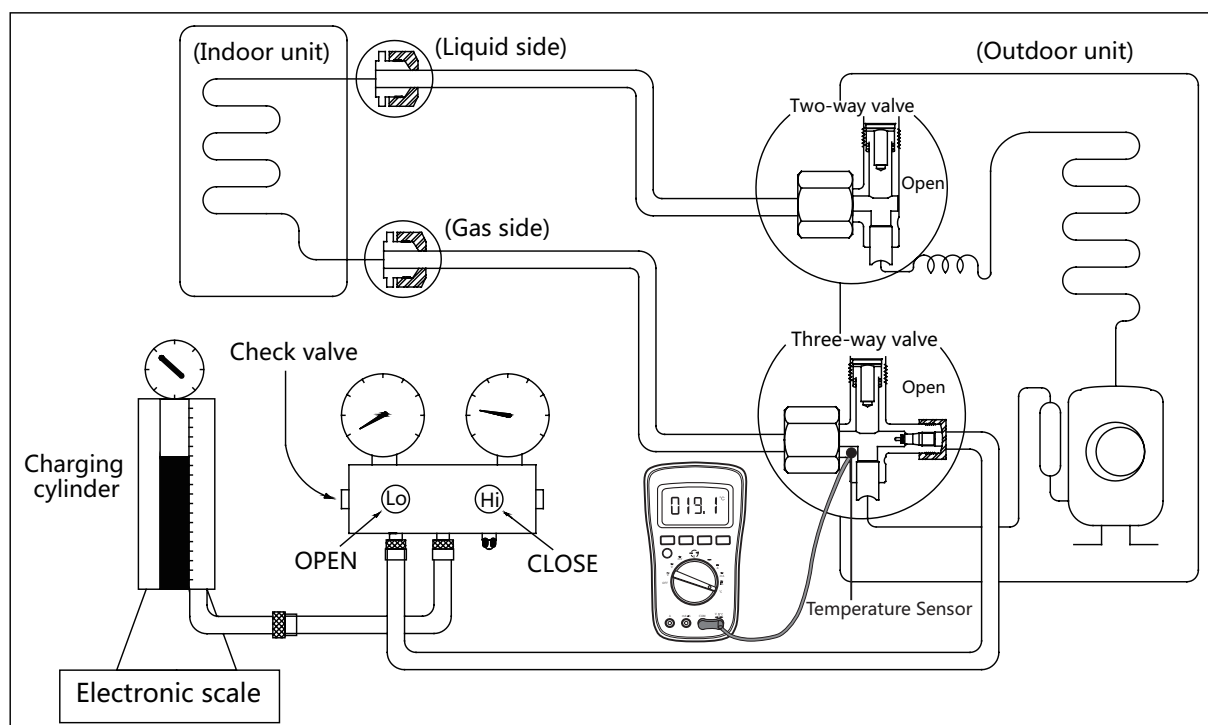

Procedure:

1. Close both 2- and 3-way valves.
2. Slightly connect the Handle Lo charge hose to the 3-way service port.
3. Connect the charge hose to the valve at the bottom of the cylinder.
4. If the refrigerant is R410A/R32, invert the cylinder to ensure a complete liquid charge.
5. Open the valve at the bottom of the cylinder for 5 seconds to purge the air in the charge hose, then fully tighten the charge hose with push pin Handle Lo to the service port of 3-way valve..
6. Place the charging cylinder onto an electronic scale and record the starting weight.
7. Fully open the Handle Lo manifold valve, 2- and 3-way valves.
8. Operate the air conditioner in cooling mode to charge the system with liquid refrigerant.
9. When the electronic scale displays the correct weight (refer to the gauge and the pressure of the low side to confirm, the value of pressure refers to chapter Appendix), turn off the air conditioner, then disconnect the charge hose from the 3-way service port immediately..
10. Mount the caps of service port and 2- and 3-way valves.
11. Use a torque wrench to tighten the caps to a torque of 18 N.m.
12. Check for gas leakage.

Note: 1. Mechanical connectors used indoors shall comply with local regulations.

2. When mechanical connectors are reused indoors, sealing parts shall be renewed. When flared joints are reused indoors, the flare part shall be re-fabricated.

Troubleshooting

Contents

1.	Safety Caution	3
2.	General Troubleshooting	4
3.	Complain Record Form	6
4.	Information Inquiry	8
5.	Error Diagnosis and Troubleshooting Without Error Code.....	13
	5.1 Remote maintenance.....	13
	5.2 Field maintenance	14
6.	Quick Maintenance by Error Code.....	19
7.	Troubleshooting by Error Code.....	19
	TS01 EEPROM Parameter Error Diagnosis and Solution	
	TS02 Indoor and Outdoor Unit Communication Error Diagnosis and Solution	
	TS03 Zero-crossing Signal Detection Error Diagnosis and Solution	
	TS04 Fan Speed is Operating Outside of The Normal Range Diagnosis and Solution	
	TS05 Open Circuit or Short Circuit of Temperature Sensor Diagnosis and Solution	
	TS06 Refrigerant Leakage Detection Diagnosis and Solution	
	TS07 Indoor PCB/Display Board Communication Error Diagnosis and Solution	
	TS08 Current Overload Protection Diagnosis and Solution	
	TS09 IPM Malfunction or IGBT Over-strong Current Protection Diagnosis and Solution	

Troubleshooting

Contents

- TS10 Over Voltage or Too Low Voltage Protection Diagnosis and Solution
- TS11 Top temperature Protection of Compressor or High Temperature Protection of IPM Module or High Pressure Protection Diagnosis and Solution
- TS12 Inverter Compressor Drive Error Diagnosis and Solution
- TS26 High pressure protection or Low pressure protection Diagnosis and Solution
- TS14 Indoor units mode conflic Diagnosis and Solution
- TS33 Communication error between outdoor main chip and compressor driven chip Diagnosis and Solution
- TS34 AP mode is active but there is no WIFI kit installed Diagnosis and Solution

8. Check Procedures

1. Safety Caution

! WARNING

Be sure to turn off all power supplies or disconnect all wires to avoid electric shock. While checking indoor/outdoor PCB, please equip oneself with antistatic gloves or wrist strap to avoid damage to the board.

! WARNING

Electricity remains in capacitors even when the power supply is off. Ensure the capacitors are fully discharged before troubleshooting.

Test the voltage between P and N on back of the main PCB with multimeter. If the voltage is lower than 36V, the capacitors are fully discharged. For models that cannot be measured, wait 5 minutes after the power supply is off to ensure that the capacitors are fully discharged.

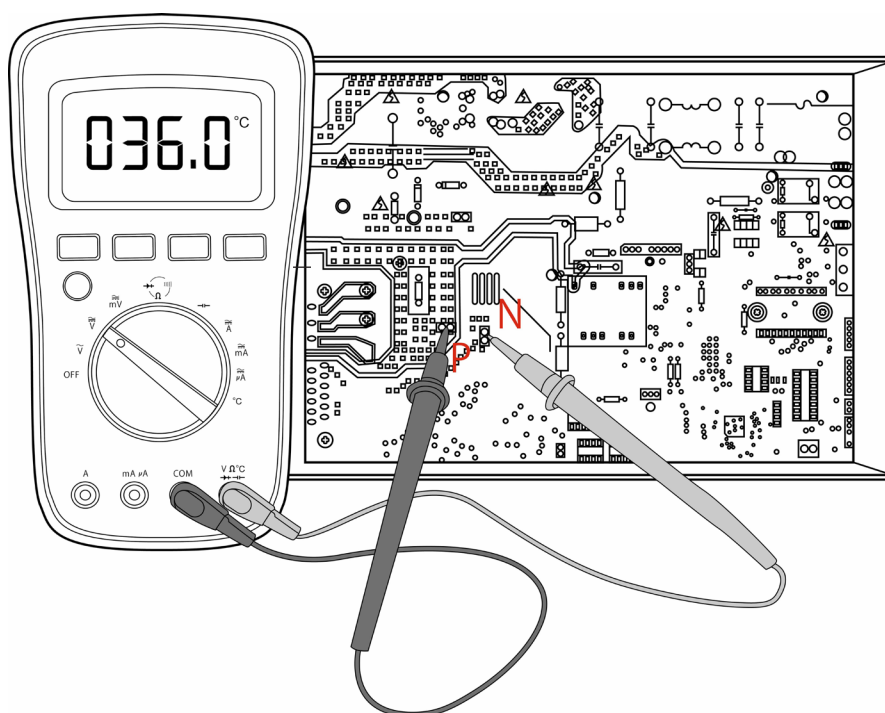

Note: This picture is for reference only. Actual appearance may vary.

2. General Troubleshooting

2.1 Error Display (Indoor Unit)

When the indoor unit encounters a recognized error on different models ,

1. the running LED with flash in a corresponding series, the timer LED may turn on or begin flashing;
2. an error code will be displayed;
3. both 1 and 2.

These error codes are described in the following tables:

Running Lamp	Timer Lamp	Display	Information	Solution
--	--	dF	Defrost	Normal Display, not error code
--	--	CL	Filter cleaning reminder(power on display for 15 seconds)	
--	--	CL	Active clean	
--	--	rF	Filter replacement reminder(power on display for 15 seconds)(for some models)	
--	--	FP	Heating in room temperature under 8°C	
--	--	FC	Forced cooling	
--	--	FP	AP mode of WIFI connection	
--	--	CP	Remote switched off	
1 time	OFF	E400/E40A	Indoor unit EEPROM parameter error	TS01-IDU
2 times	OFF	E401	Indoor/outdoor unit communication error	TS02-S-INV
3 times	OFF	E402	Zero-crossing signal detection error	TS03
4 times	OFF	E403	The indoor fan speed is operating outside of the normal range	TS04-S-IDU
5 times	OFF	E451	Outdoor unit EEPROM parameter error	TS01-ODU
5 times	OFF	E452	Condenser coil temperature sensor T3 is in open circuit or has short circuited	TS05-ODU
5 times	OFF	E453	Outdoor room temperature sensor T4 is in open circuit or has short circuited	TS05-ODU
5 times	OFF	E454	Compressor discharge temperature sensor TP is in open circuit or has short circuited	TS05-ODU
5 times	OFF	E456	Evaporator coil outlet temperature sensor T2B is in open circuit or has short circuited(for free-match indoor units)	TS05-ODU
6 times	OFF	E460	Indoor room temperature sensor T1 is in open circuit or has short circuited	TS05-IDU
6 times	OFF	E461	Evaporator coil middle temperature sensor T2 is in open circuit or has short circuited	TS05-IDU
12 times	OFF	E407	The outdoor fan speed is operating outside of the normal range	TS04-ODU
9 times	OFF	E40b	Indoor PCB/Display board communication error	TS07
8 times	OFF	E40c	Refrigerant leakage detection	TS06-INV
7 times	FLASH	P400	IPM malfunction or IGBT over-strong current protection	TS09-S
2 times	FLASH	P401	Over voltage or over low voltage protection	TS10-S

3 times	FLASH	PC02	Top temperature protection of compressor or High temperature protection of IPM module or High pressure protection	TS11-S-INV
5 times	FLASH	PC04	Inverter compressor drive error	TS12-S
1 time	FLASH	PC08	Current overload protection	TS08-S
6 times	FLASH	PC40	Communication error between outdoor main chip and compressor driven chip	TS33
7 times	FLASH	PC03	High pressure protection or low pressure protection	TS26-INV
-	-	FX0P	AP mode is active but there is no WIFI kit installed	TS34
1 times	ON	--	Indoor units mode conflict(match with multi outdoor unit)	TS14

For other errors:

The display board may show a garbled code or a code undefined by the service manual. Ensure that this code is not a temperature reading.

Troubleshooting:

Test the unit using the remote control. If the unit does not respond to the remote, the indoor PCB requires replacement. If the unit responds, the display board requires replacement.

88 flash frequency:

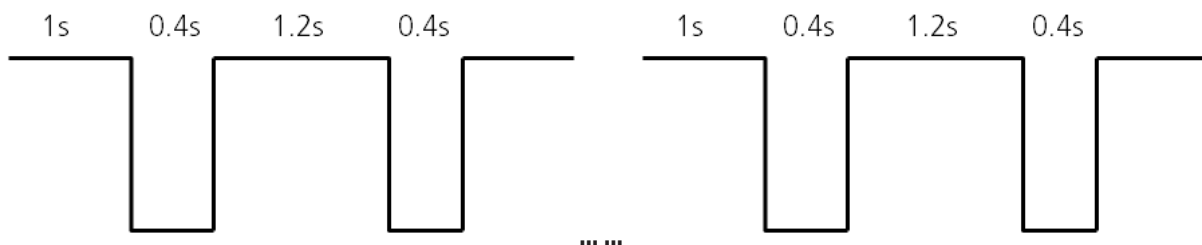

3. Complain Record Form

Complain Record Form

Request No.:

Date:

Installation Date:

Service Date:

Customer Information			
Name		Telephone No.	
Home Address			
Email			
Product Information			
Indoor Unit Model		Outdoor Unit Model	
Serial No. of indoor unit			
Serial No. of outdoor unit			
Working Mode	<input type="checkbox"/> Cooling <input type="checkbox"/> Heating <input type="checkbox"/> Fan only <input type="checkbox"/> Dry		
Setting temperature	_____°C / °F	Fan speed	<input type="checkbox"/> Turbo <input type="checkbox"/> High <input type="checkbox"/> Medium <input type="checkbox"/> Low <input type="checkbox"/> Auto
Temperature of air inlet	_____°C / °F	Temperature of air outlet	_____°C / °F
Installation / Condition Information			
Indoor temperature	_____°C / °F	Indoor humidity	_____ %RH
Outdoor temperature	_____°C / °F	Outdoor humidity	_____ %RH
Length of Connecting pipe		Pipe diameter	Gas pipe: Liquid pipe:
Length of Wiring		wire diameter	
System Running Pressure	_____MPa or _____Bar or _____PSI		
Room size (L*W*H)			
Photo of Installation of Indoor unit (Photo #1)		Photo of Installation of Outdoor unit (Photo #2)	
Failure Description			
Error Code of Indoor unit		Code of Outdoor PCB	
Unit does not start			
Remote control does not work			
Indoor display shows nothing			
No cooling or heating at all			
Less cooling or heating			
Unit starts but stops shortly			
High noise			
High vibration			

Parameter Checking information by Remote controller			
Displaying code	Displaying code meaning	Display value	Display value meaning
T1	Room temperature		
T2	Indoor coil temperature		
T3	Outdoor coil temperature		
T4	Ambient temperature		
TP	Discharge temperature		
FT	Targeted Frequency		
Fr	Actual Frequency		
dL	Compressor current		
Uo	Outdoor AC voltage		
Sn	Indoor capacity test	/	N/A
--	Reserve	/	N/A
Pr	Outdoor fan speed		
Lr	EXV opening steps		
ir	Indoor fan speed		
HU	Indoor humidity		
TT	Adjusted setting temperature		
DT	Reserve	/	N/A
iF	Reserve	/	N/A
nA	Reserve	/	N/A
oT	GA algorithm frequency		

Approval from Manufacturer	
<input type="checkbox"/> Approved	
<input type="checkbox"/> More Proof needed	
<input type="checkbox"/> Rejected	

4. Information Inquiry&Setting

- To enter engineer mode, in power-on or standby mode, and in non-locked state, press the key combination "ON/OFF + Air Speed" for 7s:
- After entering the engineer mode, the remote control will display icons of "Auto, Cool, Dry, Heat", and the Battery icon; at the same time, it will also display the numeric code of the current engineer mode (for the initial engineer mode, the numeric code displayed is 0), and all other icons are inactive.
- In engineer mode, the value of the current numeric code can be adjusted circularly through the Up/Down key, with the setting range of 0 to 30. Each time the current numeric code is adjusted, the special code of the engineer mode will be transmitted with a delay of 0.6s. The code can also be transmitted by pressing "OK", and the special code of the engineer mode sent contains information of the currently displayed numeric code (if the numeric code is 0, the code to enter the engineer mode will be transmitted).
- In engineer mode, other keys or operations are invalid except for the On/Off key, the Up/Down key, the OK key or executing the operation to exit the engineer mode.

Code	Query Content	Advanced Function Setting
0	Error code	/
1	T1 temperature	press "On/Off" for 2s to enter the Power Down Memory Selector, the code displayed is "Ch", press "OK" to send the Query Power Down Memory Selector code; press the Up/Down key to select 1 or 0 and press "OK" to confirm, 1 indicates that the power down memory exists, and 0 indicates that no power down memory exists; and press "On/Off" for 2s to exit. (Set within 1 minute after power on)
2	T2 temperature	press "On/Off" for 2s to enter the Internal Fan Control Selector after the pre-set temperature is reaches, the code displayed is "Ch", press "OK" to send the Query Internal Fan Control Selector code; press the Up/Down key to select 1 to 11: 1 - Stop the fan, 2 - Min. air speed, 3 - Set the air speed, 4 - Termal stop for 4min running for 1min, 5 - Termal stop for 8min running for 1min, 6 - Termal stop for 16min running for 1min, 7 - Termal stop for 24min running for 1min, 8 - Termal stop for 48min running for 1min, 9 - Termal stop for 15min running for 2.5min, 10 - Termal stop for 30min running for 2.5min and 11 - Termal stop for 60min running for 2.5min, press "OK" to confirm, and press "On/Off" for 2s to exit.(Item 5~11 are valid for some models)(Set within 1 minute after power on)
3	T3 temperature	press "On/Off" for 2s to enter the Mode Selector, press the Up/Down key to select CH (cool and heat, Auto + Cool + Dry + Heat + Fan), HH (Heat only, Heat only + Fan), CC(Cool only, Auto + Cool + Dry + Fa) or nU (Cool and Heat without Auto, Cool + Dry + Heat + Fan), press "OK" to confirm, and the mode selected can be memorized when the remote control is powered down and powered on; and press "On/Off" for 2s to exit. When the remote control does not burn any parameters, the mode setting will not be memorized.(CC or nU is valid for some models)(Set within 1 minute after power on)
4	T4 temperature	press the "On/Off" for 2s to enter the Min. Set Temperature Selector, press the Up/Down key to select "16°C~24°C", press "OK" to confirm, and the Min. Set Temperature can be memorized when the remote control is powered on and power lost; and press "On/Off" for 2s to exit. When the remote control does not burn any parameters, the min. set temperature will not be memorized.(Set within 1 minute after power on)
5	TP temperature	press "On/Off" for 2s to enter the Max. Set Temperature Selector, press the Up/Down key to select "25°C~30°C", press "OK" to confirm, and the Max. Set Temperature can be memorized when the remote control is powered on and power lost; and press "On/Off" for 2s to exit. When the remote control does not burn any parameters, the max. set temperature will not be memorized.(Set within 1 minute after power on)

6	Compressor Target Frequency FT	press "On/Off" for 2s to enter the Multi-split Cooling and Heating Preference Selector, the code displayed is "Ch", press "OK" to send the Query Multi-split Cooling and Heating Preference Selector code; press the Up/Down key to select H (heating preferred), C (cooling preferred) or A (master settings), press "OK" to confirm; and press "On/Off" for 2s to exit.(Set within 1 minute after power on)(Only multi models are effective)
7	Compressor Running Frequency Fr	/
8		/
9	Current AC Voltage Uo	/
10		/
11		press "On/Off" for 2S to enter the Min. Desired Cooling Frequency Selector, the code displayed is Ch, press "OK" to send the Query Min. Desired Cooling Frequency Selector code; press the Up/Down key to select the minimum cooling frequency desired and press "OK" to confirm; press "On/Off" for 2s to exit.(Range:10-50Hz,--; "--" cancels the Settings)(for some models) (Set within 1 minute after power on)
12	Set Speed Pr of the outdoor fan	press "On/Off" for 2s to enter the Min. Desired Heating Frequency Selector, the code displayed is "Ch", press "OK" to send the Query Min. Desired Heating Frequency Selector code; press the Up/Down key to select the min. desired heating frequency value, press "OK" to confirm; and press the "On/Off" for 2s to exit.(Range:10-50Hz,--; "--" cancels the Settings) (for some models)(Set within 1 minute after power on)
13	Opening Lr of EEV	press "On/Off" for 2s to enter the Max. Running Frequency Selector of the restricted area 6 in the cooling mode T4, the code displayed is "Ch", press "OK" to send the Query Max. Running Frequency Selector code of the restricted area 6 in the cooling mode T4; press the Up/Down key to select the limit, then press "OK" to confirm; and press "On/Off" for 2s to exit. (Range:20-150Hz,--; "--" cancels the Settings)(for some models)
14	Actual Running Speed ir of the indoor fan	press "On/Off" for 2s to enter the Resonance Point Frequency Selector, the code displayed is "Ch", press "OK" to send the Resonance Point Frequency Selector code; press the Up/Down key to select the outdoor forced running frequency("10-250Hz"), then press "OK" to confirm; and press "On/Off" for 2s to exit.(Range:10-250Hz,--; "--" cancels the Settings)(for some models)
15	Indoor Humidity Hu	press "On/Off" for 2s to enter the Outdoor Forced Running Frequency Selector, the code displayed is "Ch", press "OK" to send the Query Outdoor Forced Running Frequency Selector code; press the Up/Down key to select the outdoor forced running frequency("10-250Hz"), then press "OK" to confirm; and press "On/Off" for 2s to exit.(Range:10-250Hz,--; "--" cancels the Settings)(for some models)
16	Set Temperature TT after compensation	press "On/Off" for 2s to enter One-Key Recovery, the code displayed is "rS", then press "OK" to send the One-Key Recovery code, the mode selector of the remote control will recover to "Cooling and heating", the min. temperature recovers to 16°C, and the max. temperature recovers to 30°C; and press "On/Off" for 2s to exit.(for some models)
17	/	/
18	WIFI signal strength	/

19	Dc bus voltage AD value	press "On/Off" for 2s to enter the Cooling Frequency Threshold Settings; press the Up/Down key to select the cooling frequency threshold, press "OK" to confirm; and press the "On/Off" for 2s to exit. (Range:40,41.....83,84,-,-;"--" cancels the Settings)(Set within 1 minute after power on)
20	Indoor Target Frequency oT	press "ON/OFF" for 2s to enter the Heating Frequency Threshold Settings; press the Up/Down key to select the heating frequency threshold, press "OK" to confirm; and press "On/Off" for 2s to exit.(Range:40,41.....83,84,-,-;"--" cancels the Settings) (Set within 1 minute after power on)
21	Reserve	press "On/Off" for 2s to enter the Cooling Temperature Compensation Value Settings, the code displayed is "Ch", then press "OK" to send the Query Cooling Temperature Compensation Value code; press the Up/Down key to select the cooling temperature compensation value, then press "OK"; and press "On/Off" for 2s to exit.(Range:-3.0,-2.5,-2.0...2.0,2.5,3.0,3.5,-,-;"--" cancels the Settings)
22		press "On/Off" for 2s to enter the Heating Temperature Compensation Value Settings, the code displayed is "Ch", press "OK" to send the Query Heating Temperature Compensation Value code; press the Up/Down key to select the heating temperature compensation value, then press "OK"; and press "On/Off" for 2s to exit.(Range:-6.5,-6,...1.0,1.5,2.0...6.0,6.5,7.0,7.5,-,-;"--" cancels the Settings)
23		press "On/Off" for 2s to enter the Max. Cooling Air Speed Settings, the code displayed is "Ch", press "OK" to send the Query Max. Cooling Air Speed code; press the Up/Down key to select the max. cooling air speed, then press "OK"; and press "On/Off" for 2s to exit.(Range: -41,-40,-39...17,18,19,20,-,-;"--" cancels the Settings)
24		press "On/Off" for 2S to enter the Min. Cooling Air Speed Settings, the code displayed is "Ch", press "OK" to send the Query Min. Cooling Air Speed code; press the Up/Down key to select the minimum cooling air speed and press "OK" to confirm; press "On/Off" for 2s to exit.(Range: -41,-40,-39...17,18,19,20,-,-;"--" cancels the Settings)
25		press "On/Off" for 2s to enter the Max. Heating Air Speed Settings, the code displayed is "Ch", press "OK" to send the Query Max. Heating Air Speed code; press the Up/Down key to select the maximum heating air speed and press "OK" to confirm; press "On/Off" for 2s to exit.(Range: -41,-40,-39...17,18,19,20,-,-;"--" cancels the Settings)
26		press "On/Off" for 2s to enter the Min. Heating Air Speed Settings, the code displayed is "Ch", press "OK" to send the Query Min. Heating Air Speed code; press the Up/Down key to select the minimum heating air speed and press "OK" to confirm; press "On/Off" for 2s to exit.(Range: -41,-40,-39...17,18,19,20,-,-;"--" cancels the Settings)
27		/
28		
29		
30		

- In Channel 1~30 settings of the engineer mode, long press the On/off key to return the previous engineer mode.

Exit of engineer mode:

- 1)In engineer mode, press the key combination of "On/Off + Air speed" for 2s;
- 2)The engineer mode will be exited if there are no valid key operations for continuous 60s.

Error code of engineer mode

Display	Error Information
Eh00/Eh0A	Indoor unit EEPROM parameter error
EL01	Indoor / outdoor unit communication error
Eh1A	Communication error between indoor unit and indoor external fan module
Eh30	Parameters error of indoor external fan
Eh35	Phase failure of indoor external fan
Eh36	Indoor external fan current sampling bias fault
Eh37	Indoor external fan zero speed failure
Eh38	Indoor external fan stall failure
Eh39	Out of step failure of indoor external fan
Eh3A	Low voltage protection of indoor external fan DC bus
Eh3B	Indoor external fan DC bus voltage is too high fault
Eh3E	Indoor external fan overcurrent fault
Eh3F	Indoor external fan module protection/hardware overcurrent protection
Eh03	The indoor fan speed is operating outside of the normal range
EC51	Outdoor unit EEPROM parameter error
EC52	Condenser coil temperature sensor T3 is in open circuit or has short circuited
EC53	Outdoor room temperature sensor T4 is in open circuit or has short circuited
EC54	Compressor discharge temperature sensor TP is in open circuit or has short circuited
EC55	IGBT temperature sensor TH is in open circuit or has short circuited
EC0d	Outdoor unit malfunction
Eh60	Indoor room temperature sensor T1 is in open circuit or has short circuited
Eh61	Evaporator coil temperature sensor T2 is in open circuit or has short circuited
EC71	Outdoor external fan overcurrent fault
EC75	Outdoor external fan module protection/hardware overcurrent protection
EC72	Outdoor external fan phase failure
EC74	Outdoor external fan current sampling bias fault
EC73	Zero speed failure of outdoor unit DC fan
EC07	The outdoor fan speed is operating outside of the normal range(
EL0C	Refrigerant leak detected
Eh0E	Water-level alarm malfunction
PC00	IPM malfunction or IGBT over-strong current protection
PC10	Over low voltage protection
PC11	Over voltage protection
PC12	DC voltage protection
PC02	Top temperature protection of compressor or High temperature protection of IPM module
PC40	Communication error between outdoor main chip and compressor driven chip

PC 41	Current Input detection protection
PC 42	Compressor start error
PC 43	Lack of phase (3 phase) protection
PC 44	No speed protection
PC 45	341PWM error
PC 46	Compressor speed malfunction
PC 49	Compressor over current protection
PC 06	Compressor discharge temperature protection
PC 08	Outdoor current protection
PH 09	Anti-cold air in heating mode
PC 0F	PFC module malfunction
PC 30	System overpressure protection
PC 31	System pressure is too low protection
PC 03	Pressure protection
PC 0L	Outdoor low ambient temperature protection
PH 90	Evaporator coil temperature over high protection
PH 91	Evaporator coil temperature over low Protection
PC 0R	Condenser high temperature protection
PH 0C	Indoor unit humidity sensor failure
LH 00	Frequency limit caused by T2
LH 30	Indoor external fan current limit
LH 31	Indoor external fan voltage limit
LC 01	Frequency limit caused by T3
LC 02	Frequency limit caused by TP
LC 05	Frequency limit caused by voltage
LC 03	Frequency limit caused by current
LC 06	Frequency limit caused by PFC
LC 30	Frequency limit caused by high pressure
LC 31	Frequency limit caused by low pressure
LH 07	Frequency limit caused by remote controller
--	Indoor units mode conflict(match with multi outdoor unit)

5. Error Diagnosis and Troubleshooting Without Error Code

WARNING

Be sure to turn off unit before any maintenance to prevent damage or injury.

5.1 Remote maintenance

SUGGESTION: When troubles occur, please check the following points with customers before field maintenance.

No.	Problem	Solution
1	Unit will not start	TS15 - TS16
2	The power switch is on but fans will not start	TS15 - TS16
3	The temperature on the display board cannot be set	TS15 - TS16
4	Unit is on but the wind is not cold(hot)	TS15 - TS16
5	Unit runs, but shortly stops	TS15 - TS16
6	The unit starts up and stops frequently	TS15 - TS16
7	Unit runs continuously but insufficient cooling(heating)	TS15 - TS16
8	Cool can not change to heat	TS15 - TS16
9	Unit is noisy	TS15 - TS16

5.2 Field maintenance

	Problem	Solution
1	Unit will not start	TS17 - TS18
2	Compressor will not start but fans run	TS17 - TS18
3	Compressor and condenser (outdoor) fan will not start	TS17 - TS18
4	Evaporator (indoor) fan will not start	TS17 - TS18
5	Condenser (Outdoor) fan will not start	TS17 - TS18
6	Unit runs, but shortly stops	TS17 - TS18
7	Compressor short-cycles due to overload	TS17 - TS18
8	High discharge pressure	TS17 - TS18
9	Low discharge pressure	TS17 - TS18
10	High suction pressure	TS17 - TS18
11	Low suction pressure	TS17 - TS18
12	Unit runs continuously but insufficient cooling	TS17 - TS18
13	Too cool	TS17 - TS18
14	Compressor is noisy	TS17 - TS18
15	Horizontal louver can not revolve	TS17 - TS18

1.Remote Maintenance	Electrical Circuit					Refrigerant Circuit								
Possible causes of trouble	Power failure	The main power tripped	Loose connections	Faulty transformer	The voltage too high or too low	The remote control is powered off	Broken the remote control	Dirty air filter	Dirty condenser fins	The setting temperature is higher/lower than the room's (cooling/heating)	The ambient temperature is too high/low when the mode is cooling/heating	Fan mode	SILENCE function is activated(Optional function)	Frosting and defrosting frequently
Unit will not start	☆	☆	☆	☆										
The power switch is on but fans will not start			☆	☆	☆									
The temperture on the playboard cannot be setted						☆	☆							
Unit is on but the wind is not cold(hot)										☆	☆	☆		
Unit runs, but shortly stops					☆					☆	☆			
The unit startup and stop frequently					☆						☆			☆
Unit runs continuously but insufficient cooling(heating)								☆	☆	☆	☆		☆	
Cool can not change to heat														
Unit is noisy														
Test method / remedy	Test voltage	Close the power switch	Inspect connections - tighten	Change the transformer	Test voltage	Replace the battery of the remote control	Replace the remote control	Clean or replace	Clean	Adjust the setting temperature	Turn on the AC later	Adjust to cool mode	Turn off the SILENCE function	Turn on the AC later

1.Remote Maintenance	Others					
Possible causes of trouble	Heavy load condition	Loosen hold down bolts and / or screws	Bad airproof	The air inlet or outlet of either unit is blocked	Interference from cell phone towers and remote boosters	Shipping plates remain attached
Unit will not start						
The power switch is on but fans will not start					☆	
The temperature on the display board cannot be set						
Unit is on but the wind is not cold(hot)						
Unit runs, but shortly stops						
The unit starts up and stops frequently				☆		
Unit runs continuously but insufficient cooling(heating)	☆		☆	☆		
Cool can not change to heat						
Unit is noisy		☆				☆
Test method / remedy	Check heat load	Tighten bolts or screws	Close all the windows and doors	Remove the obstacles	Reconnect the power or press ON/OFF button on remote control to restart operation	Remove them

2.Field Maintenance	Refrigerant Circuit														Others								
Possible causes of trouble	Compressor stuck	Shortage of refrigerant	Restricted liquid line	Dirty air filter	Dirty evaporator coil	Insufficient air through evaporator coil	Overcharge of refrigerant	Dirty or partially blocked condenser	Air or incompressible gas in refrigerant cycle	Short cycling of condensing air	High temperature condensing medium	Insufficient condensing medium	Broken compressor internal parts	Inefficient compressor	Expansion valve obstructed	Expansion valve or capillary tube closed completely	Leaking power element on expansion valve	Poor installation of feeler bulb	Heavy load condition	Loosen hold down bolts and / or screws	Shipping plates remain attached	Poor choices of capacity	Contact of piping with other piping or external plate
Unit will not start																							
Compressor will not start but fans run	☆																						
Compressor and condenser (outdoor) fan will not start																							
Evaporator (indoor) fan will not start																							
Condenser (Outdoor) fan will not start																							
Unit runs, but shortly stops		☆	☆				☆	☆								☆	☆						
Compressor short-cycles due to overload		☆					☆	☆															
High discharge pressure							☆	☆	☆	☆	☆	☆											
Low discharge pressure		☆												☆									
High suction pressure							☆							☆				☆	☆				
Low suction pressure		☆	☆	☆	☆	☆								☆	☆	☆							
Unit runs continuously but insufficient cooling		☆	☆	☆	☆	☆		☆	☆	☆				☆					☆			☆	
Too cool																							
Compressor is noisy							☆						☆							☆	☆		☆
Horizontal louver can not revolve																							
Test method / remedy	Replace the compressor	Leak test	Replace restricted part	Clean or replace	Clean coil	Check fan	Change charged refrigerant volume	Clean condenser or remove obstacle	Purge, evacuate and recharge	Remove obstruction to air flow	Remove obstruction in air or water flow	Remove obstruction in air or water flow	Replace compressor	Test compressor efficiency	Replace valve	Replace valve	Replace valve	Fix feeler bulb	Check heat load	Tighten bolts or screws	Remove them	Choose AC of lager capacity or add the number of AC	Rectify piping so as not to contact each other or with external plate

2.Field Maintenance	Electrical Circuit														
Possible causes of trouble	Power failure	Blown fuse or varistor	Loose connections	Shorted or broken wires	Safety device opens	Faulty thermostat / room temperature sensor	Wrong setting place of temperature sensor	Faulty transformer	Shorted or open capacitor	Faulty magnetic contactor for compressor	Faulty magnetic contactor for fan	Low voltage	Faulty stepping motor	Shorted or grounded compressor	Shorted or grounded fan motor
Unit will not start	☆	☆	☆	☆	☆			☆							
Compressor will not start but fans run				☆		☆			☆	☆				☆	
Compressor and condenser (outdoor) fan will not start				☆		☆				☆					
Evaporator (indoor) fan will not start				☆					☆		☆				☆
Condenser (Outdoor) fan will not start				☆		☆			☆		☆				☆
Unit runs, but shortly stops										☆		☆			
Compressor short-cycles due to overload										☆		☆			
High discharge pressure															
Low discharge pressure															
High suction pressure															
Low suction pressure															
Unit runs continuously but insufficient cooling															
Too cool						☆	☆								
Compressor is noisy															
Horizontal louver can not revolve			☆	☆									☆		
Test method / remedy	Test voltage	Inspect fuse type & size	Inspect connections - tighten	Test circuits with tester	Test continuity of safety device	Test continuity of thermostat / sensor & wiring Place the temperature sensor at the central of the air inlet grille	Check control circuit with tester	Check capacitor with tester	Test continuity of coil & contacts	Test continuity of coil & contacts	Test voltage	Replace the stepping motor	Check resistance with multimeter	Check resistance with multimeter	

6. Quick Maintenance by Error Code

If you do not have the time to test which specific parts are faulty, you can directly change the required parts according the error code. You can find the parts to replace by error code in the following table.

Part requiring replacement	Error Code									
	EH00/ EH0A	EU01	EH02	EH03	EH60	EH61	EH0b	EU0C	EC56	PC08
Indoor PCB	✓	✓	✓	✓	✓	✓	✓	✓	x	x
Outdoor PCB	x	✓	x	x	x	x	x	x	✓	✓
Display board	x	x	x	x	x	x	✓	x	x	x
Indoor fan motor	x	x	x	✓	x	x	x	x	x	x
T1 sensor	x	x	x	x	✓	x	x	x	x	x
T2 Sensor	x	x	x	x	x	✓	x	✓	x	x
T2B Sensor	x	x	x	x	x	x	x	x	✓	x
Reactor	x	✓	x	x	x	x	x	x	x	x
Compressor	x	x	x	x	x	x	x	x	x	✓
Additional refrigerant	x	x	x	x	x	x	x	✓	x	x

Part requiring replacement	EC53	EC52	EC54	EC51	EC07	PC00	PC01	PC02	PC03	PC04
Outdoor PCB	✓	✓	✓	✓	✓	✓	✓	✓	✓	✓
Indoor fan motor	x	x	x	x	x	x	x	x	x	x
Outdoor fan motor	x	x	x	x	✓	✓	x	✓	x	✓
T3 Sensor	x	✓	x	x	x	x	x	x	x	x
T4 Sensor	✓	x	x	x	x	x	x	x	x	x
TP Sensor	x	x	✓	x	x	x	x	x	x	x
Reactor	x	x	x	x	x	x	✓	x	x	x
Compressor	x	x	x	x	x	✓	x	x	x	✓
IPM module board	x	x	x	x	x	✓	✓	✓	x	✓
High pressure protector	x	x	x	x	x	x	x	✓	x	x
Low pressure protector	x	x	x	x	x	x	x	x	✓	x
Additional refrigerant	x	x	x	x	x	x	x	x	✓	x

Note: For certain models, outdoor PCB could not be removed separately. In this case, the outdoor electric control box should be replaced as a whole.

7. Troubleshooting by Error Code

TS01-IDU: Indoor EEPROM parameter error diagnosis and solution

Description: Indoor PCB main chip does not receive feedback from EEPROM chip.

Recommended parts to prepare:

- Indoor PCB

Troubleshooting and repair:

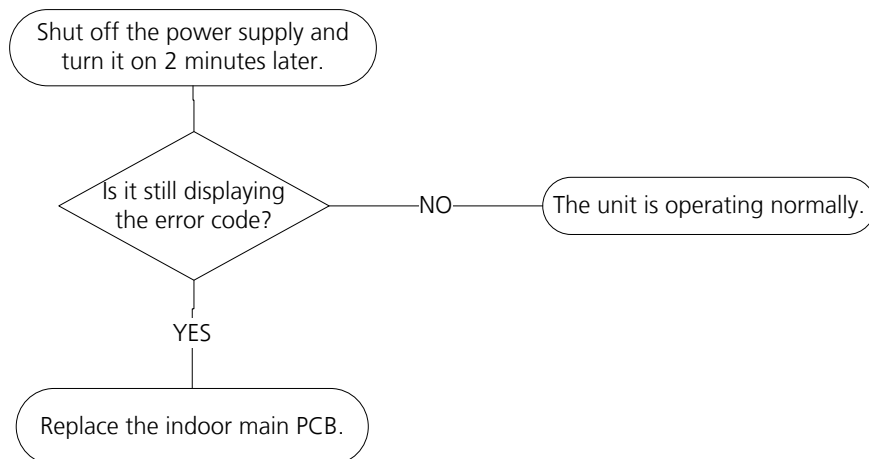

Remarks:

EEPROM: A read-only memory whose contents can be erased and reprogrammed using a pulsed voltage.

The location of the EEPROM chip on the indoor PCB is shown in the following image:

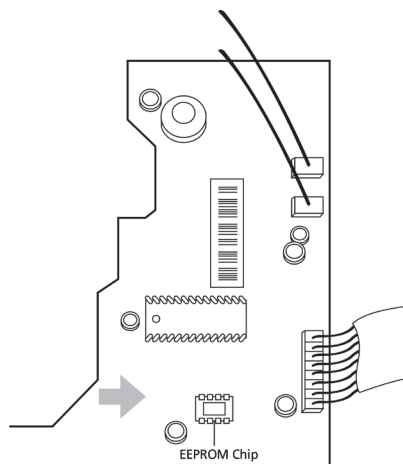

Note: This pictures are only for reference, actual appearance may vary.

TS01-ODU: Outdoor EEPROM parameter error or communication error between outdoor main chip and compressor driven chip diagnosis and solution

Description: Outdoor PCB main chip does not receive feedback from EEPROM chip or compressor driven chip.

Recommended parts to prepare:

- Outdoor PCB

Troubleshooting and repair:

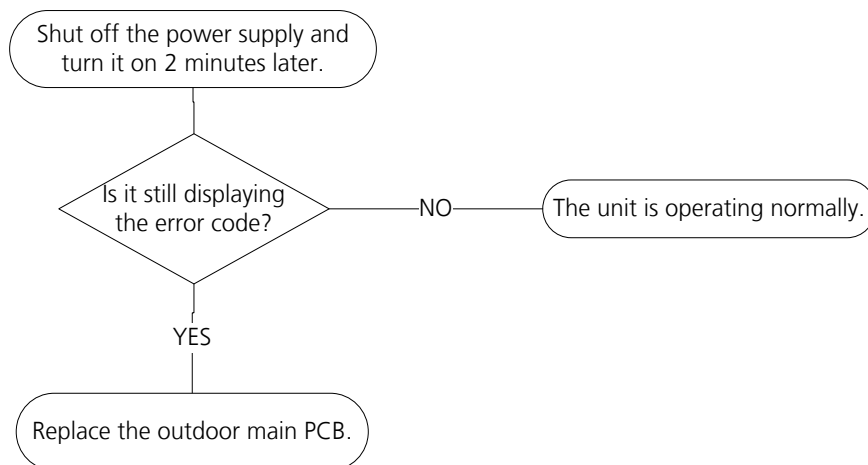

Remarks:

EEPROM: A read-only memory whose contents can be erased and reprogrammed using a pulsed voltage.

The location of the EEPROM chip on the outdoor PCB is shown in the following image:

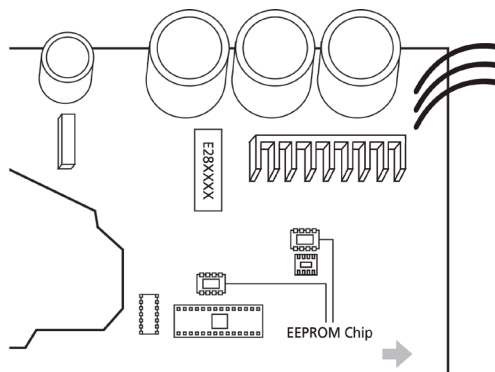

Note: For certain models, outdoor PCB could not be removed separately. In this case, the outdoor electric control box should be replaced as a whole. This pictures are only for reference, actual appearance may vary.

TS02-S-INV: Indoor and outdoor unit communication error diagnosis and solution

Description: Indoor unit can not communicate with outdoor unit

Recommended parts to prepare:

- Indoor PCB
- Outdoor PCB
- Short-circuited component

Troubleshooting and repair:

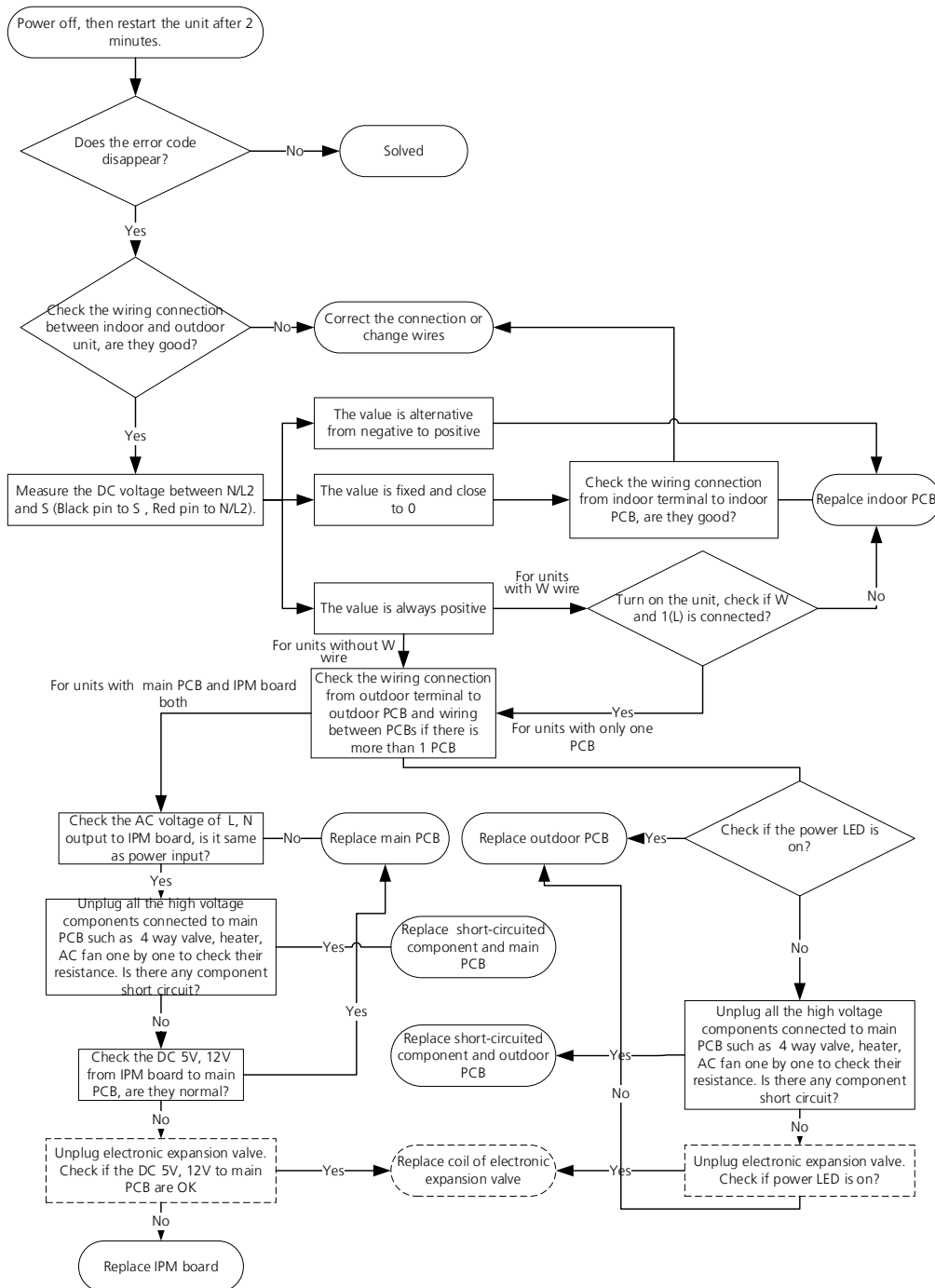

Note: For certain models, outdoor PCB could not be removed separately. In this case, the outdoor electric control box should be replaced as a whole.

Remarks:

- Use a multimeter to test the DC voltage between 2 port(or S or L2 port) and 3 port(or N or S port) of outdoor unit. The red pin of multimeter connects with 2 port(or S or L2 port) while the black pin is for 3 port(or N or S port).
- When AC is normal running, the voltage will move alternately between -25V to 25V.
- If the outdoor unit has malfunction, the voltage will move alternately with positive value.
- While if the indoor unit has malfunction, the voltage will be a certain value.

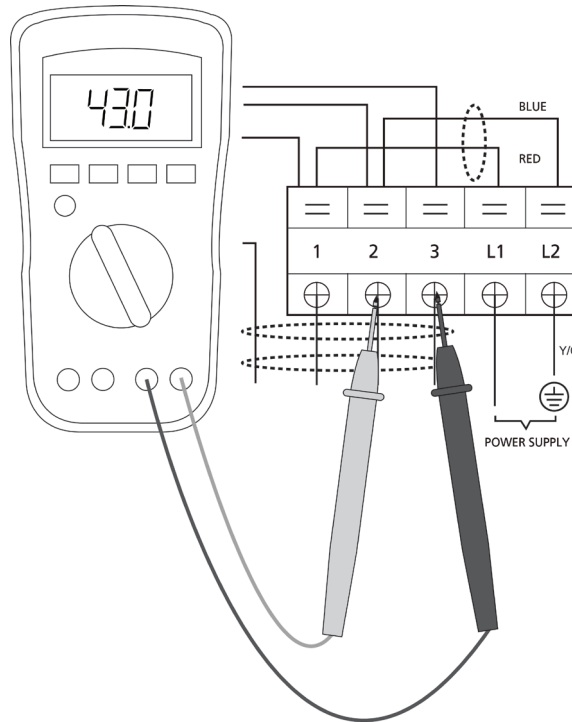

**S and N
or
L2 and S
or
2 and 3**

- Use a multimeter to test the resistance of the reactor which does not connect with capacitor.
- The normal value should be around zero ohm. Otherwise, the reactor must have malfunction.

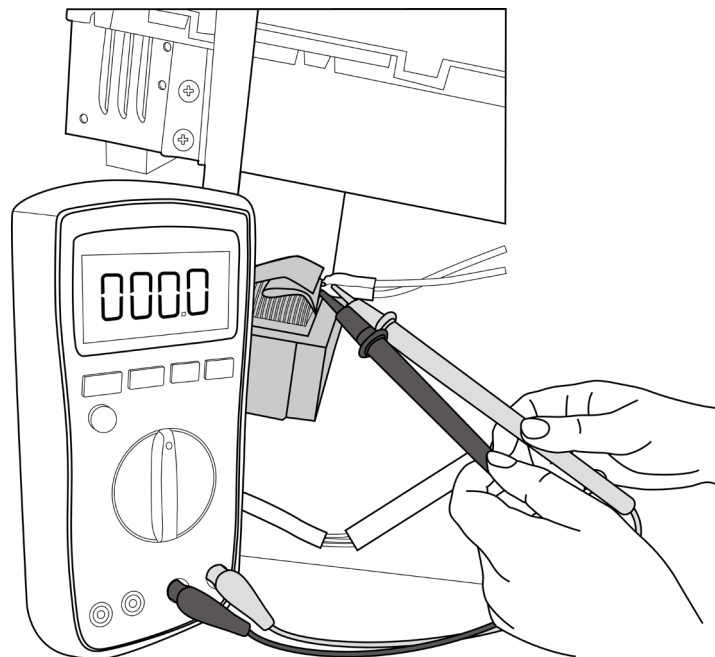

Note: The picture and the value are only for reference, actual condition and specific value may vary.

TS03: Zero crossing detection error diagnosis and solution

Description: When PCB does not receive zero crossing signal feedback for 4 minutes or the zero crossing signal time interval is abnormal.

Recommended parts to prepare:

- Connection wires
- Indoor main PCB

Troubleshooting and repair:

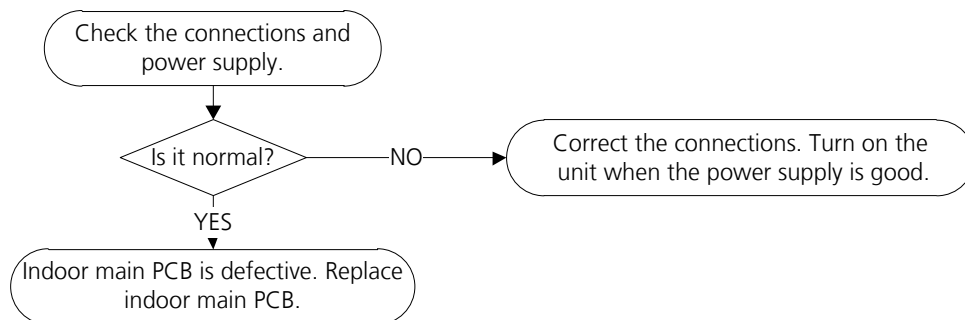

Note: E2 zero crossing detection error is only valid for the unit with AC fan motor, for other models, this error is invalid.

TS04-S-IDU: The Indoor fan speed is operating outside of normal range diagnosis and solution)

Description: When indoor fan speed keeps too low or too high for a certain time, the LED displays the failure code and the AC turns off.

Recommended parts to prepare:

- Connection wires
- Fan assembly
- Fan motor
- Indoor main PCB

Troubleshooting and repair:

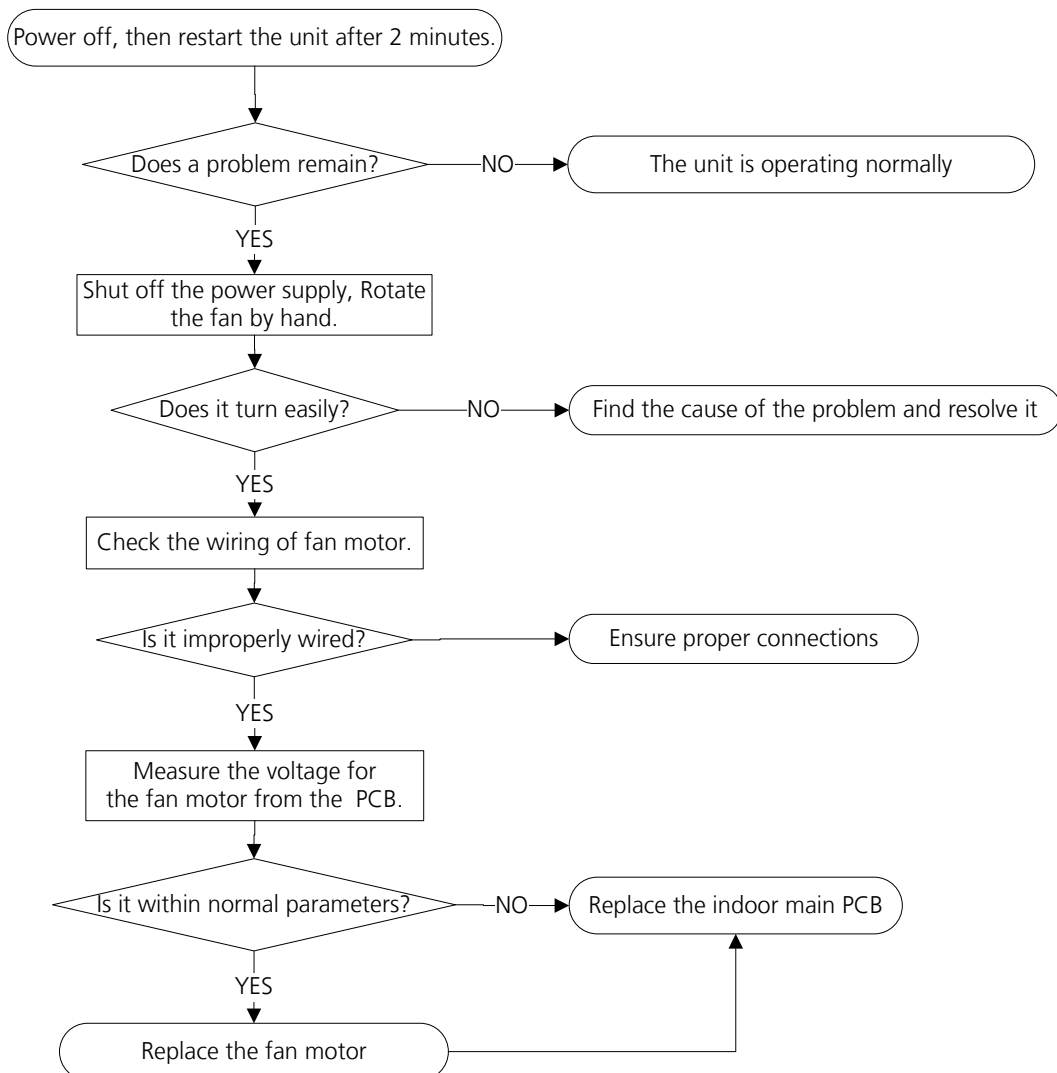

Index:

1. Indoor or Outdoor DC Fan Motor(control chip is in fan motor)

Power on and when the unit is in standby, measure the voltage of pin1-pin3, pin4-pin3 in fan motor connector. If the value of the voltage is not in the range showing in below table, the PCB must has problems and need to be replaced.

- DC motor voltage input and output (voltage: 220-240V~):

No.	Color	Signal	Voltage
1	Red	Vs/Vm	192V~380V
2	---	---	---
3	Black	GND	0V
4	White	Vcc	14-17.5V
5	Yellow	Vsp	0~5.6V
6	Blue	FG	14-17.5V

- DC motor voltage input and output (voltage: 115V~):

No.	Color	Signal	Voltage
1	Red	Vs/Vm	140V~190V
2	---	---	---
3	Black	GND	0V
4	White	Vcc	14-17.5V
5	Yellow	Vsp	0~5.6V
6	Blue	FG	14-17.5V

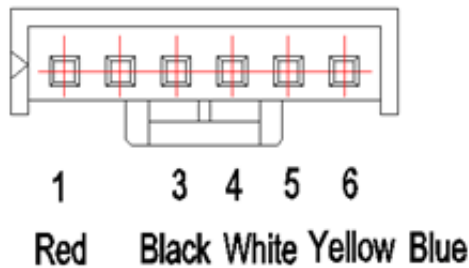

2. Indoor AC Motor

- 1) Power on and set the unit running in fan mode at high fan speed. After running for 15 seconds, measure the voltage of pin1 and pin2. If the value of the voltage is less than 100V(208~240V power supply) or 50V (115V power supply), the PCB must has problems and need to be replaced.

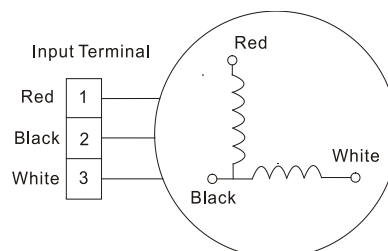

TS04-ODU: The outdoor fan speed is operating outside of normal range diagnosis and solution)

Description: When outdoor fan speed keeps too low or too high for a certain time, the LED displays the failure code and the AC turns off.

Recommended parts to prepare:

- Connection wires
- Fan assembly
- Fan motor
- Outdoor main PCB

Troubleshooting and repair:

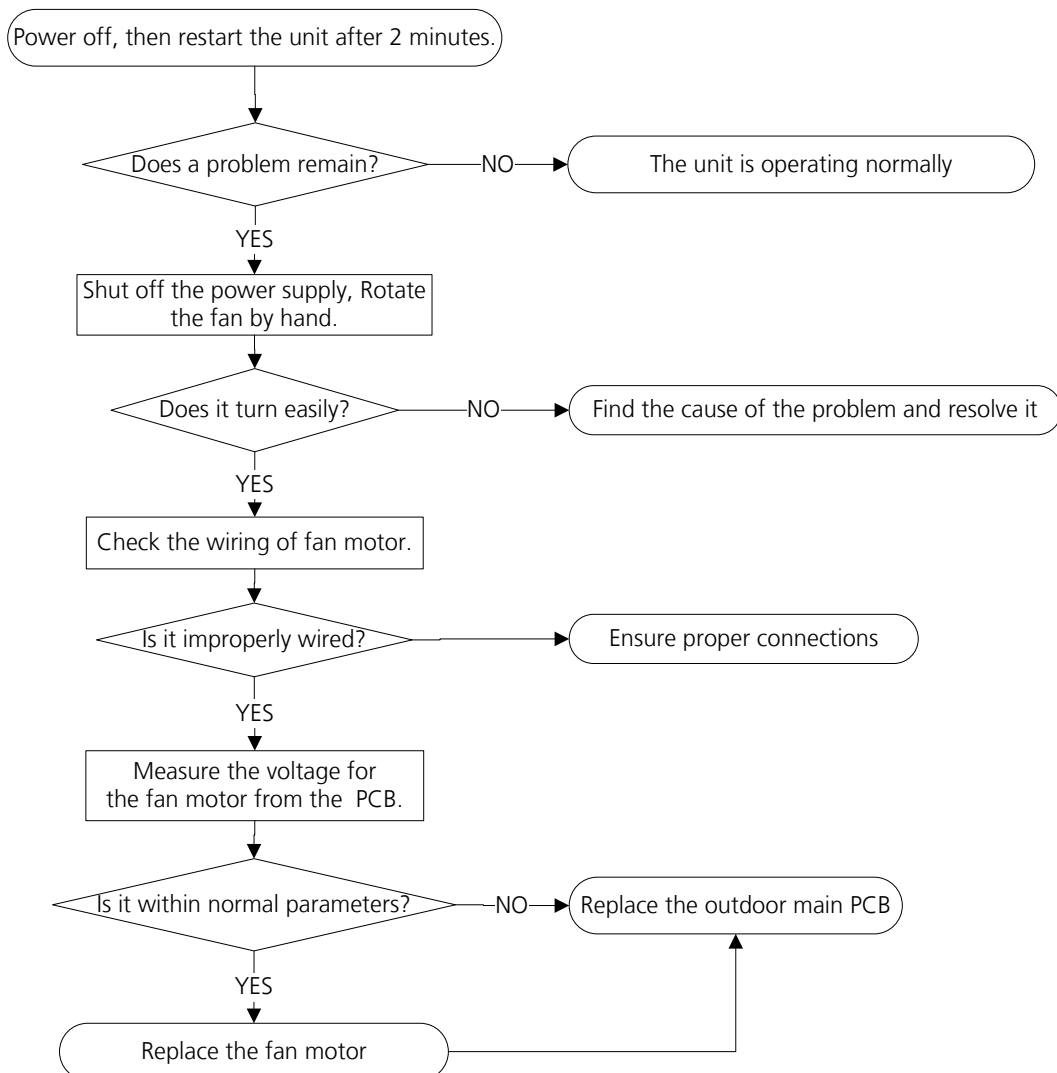

Note: For certain models, outdoor PCB could not be removed separately. In this case, the outdoor electric control box should be replaced as a whole.

Index:

1. Outdoor DC Fan Motor (control chip is in outdoor PCB)

Release the UVW connector. Measure the resistance of U-V, U-W, V-W. If the resistance is not equal to each other, the fan motor must have problems and need to be replaced. otherwise the PCB must have problems and need to be replaced.

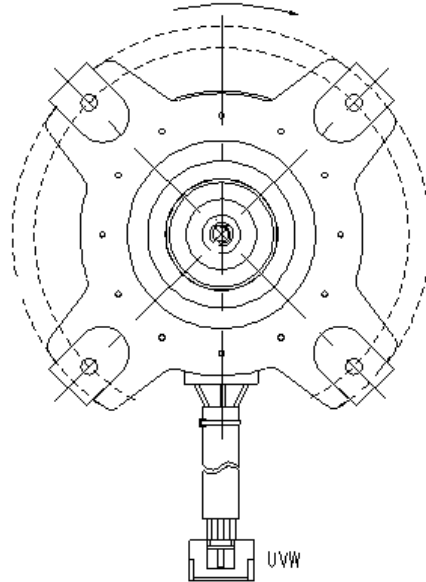

2. DC Fan Motor(control chip is in fan motor, single fan)

Power on and when the unit is in standby, measure the voltage of pin1-pin3, pin4-pin3 in fan motor connector. If the value of the voltage is not in the range showing in below table, the PCB must have problems and need to be replaced.

No.	Color	Signal	Voltage
1	Red	Vs/Vm	192V~380V
2	---	---	---
3	Black	GND	0V
4	White	Vcc	13.5-16.5V
5	Yellow	Vsp	0~6.5V
6	Blue	FG	13.5-16.5V

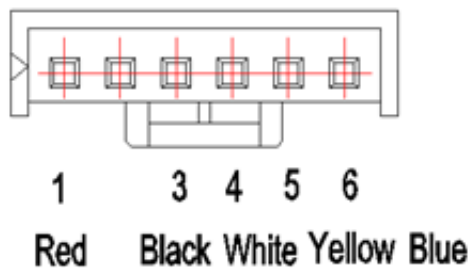

TS05-IDU: Open circuit or short circuit of indoor temperature sensor(T1, T2) diagnosis and solution

Description: If the sampling voltage is lower than 0.06V or higher than 4.94V, the LED displays the failure code.

Recommended parts to prepare:

- Connection wires
- Sensors
- Indoor main PCB

Troubleshooting and repair:

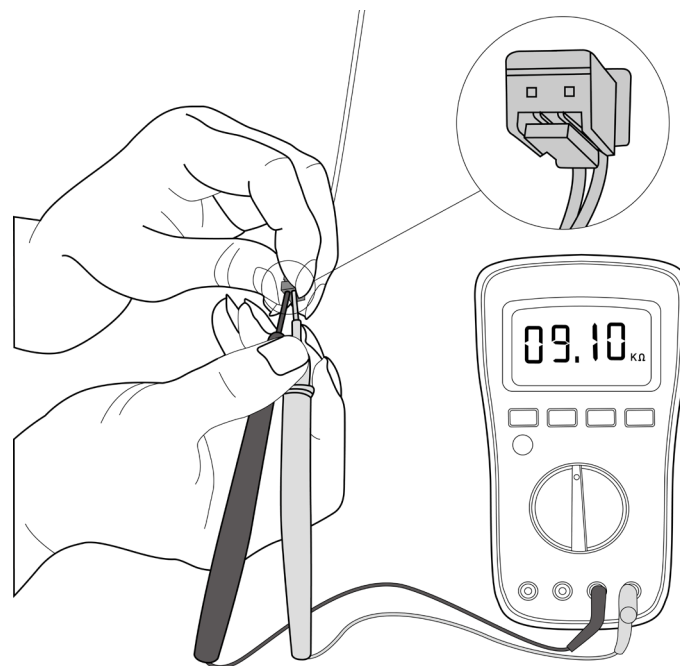
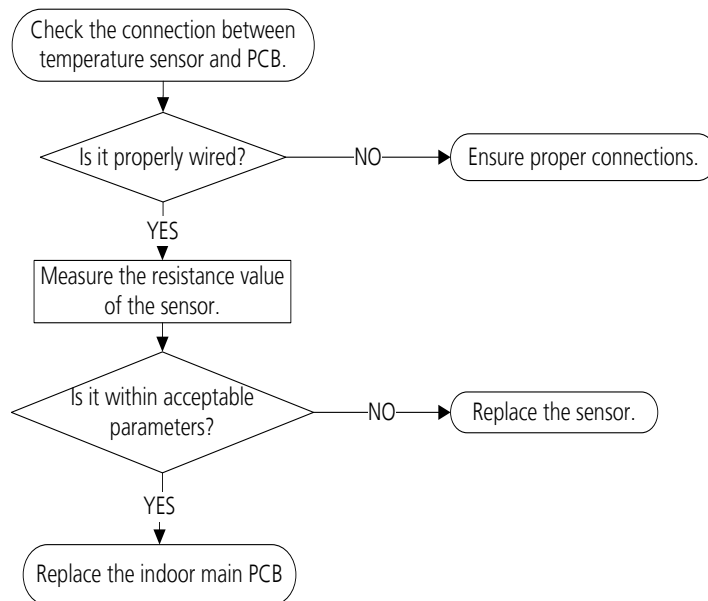

Note: This picture and the value are only for reference, actual appearance and value may vary.

TS05-ODU: Open circuit or short circuit of outdoor temperature sensor(T3, T4, TP, T2B,TH) diagnosis and solution

Description: If the sampling voltage is lower than 0.06V or higher than 4.94V, the LED displays the failure code.

Recommended parts to prepare:

- Connection wires
- Sensors
- Outdoor main PCB

Troubleshooting and repair:

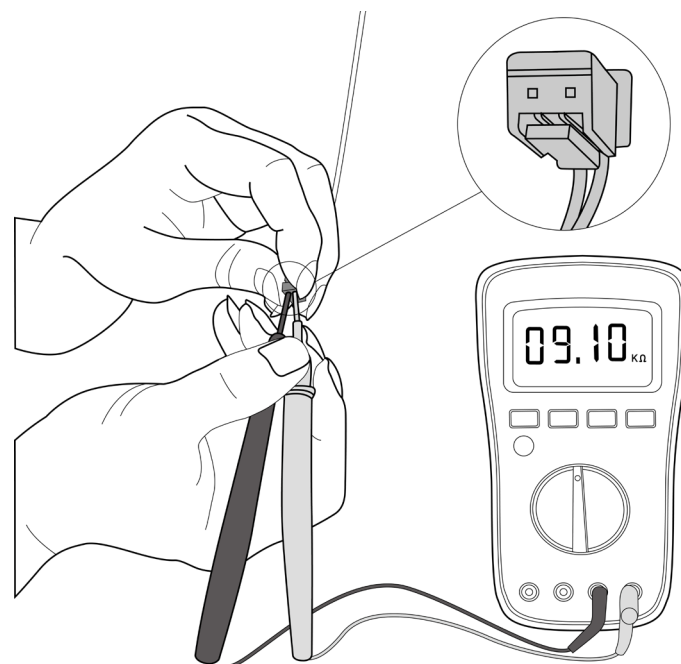
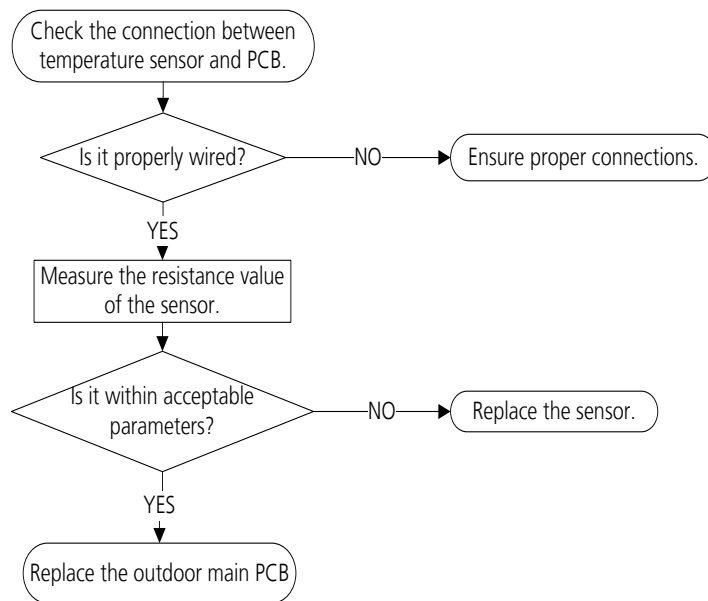

Note: For certain models, outdoor PCB could not be removed separately. In this case, the outdoor electric control box should be replaced as a whole. For certain models, outdoor unit uses combination sensor, T3,T4 and TP are the same of sensor. This picture and the value are only for reference, actual appearance and value may vary.

TS06-INV: Refrigerant Leakage Detection diagnosis and solution

Description:

Judging the abnormality of the refrigeration system according to the number of compressor stops and the changes in operating parameters caused by excessive exhaust temperature.

Recommended parts to prepare:

- Indoor PCB
- Additional refrigerant

Troubleshooting and repair:

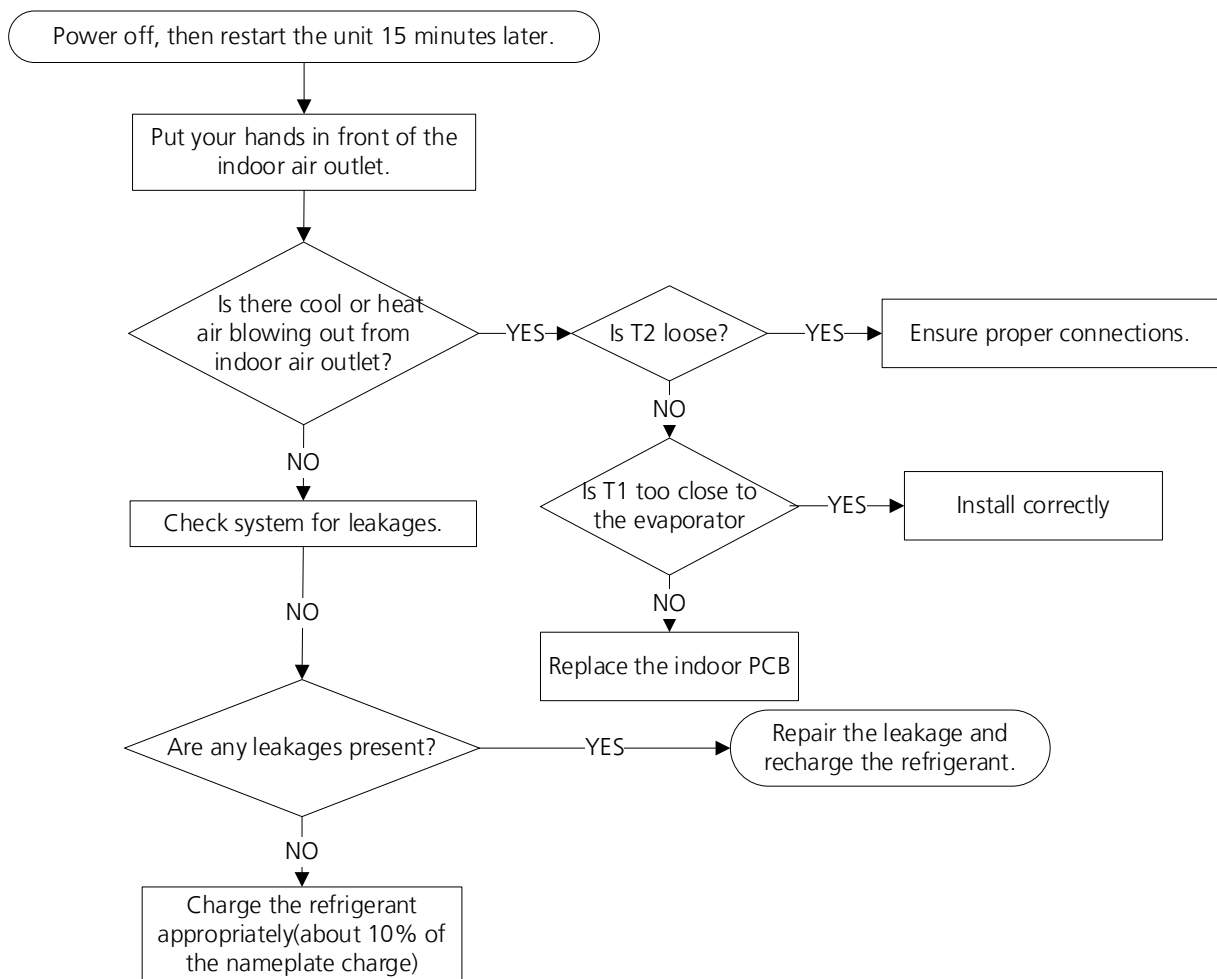

TS07: Indoor PCB / Display board communication error diagnosis and solution

Description: Indoor PCB does not receive feedback from the display board.

Recommended parts to prepare:

- Communication wire
- Indoor PCB
- Display board

Troubleshooting and repair:

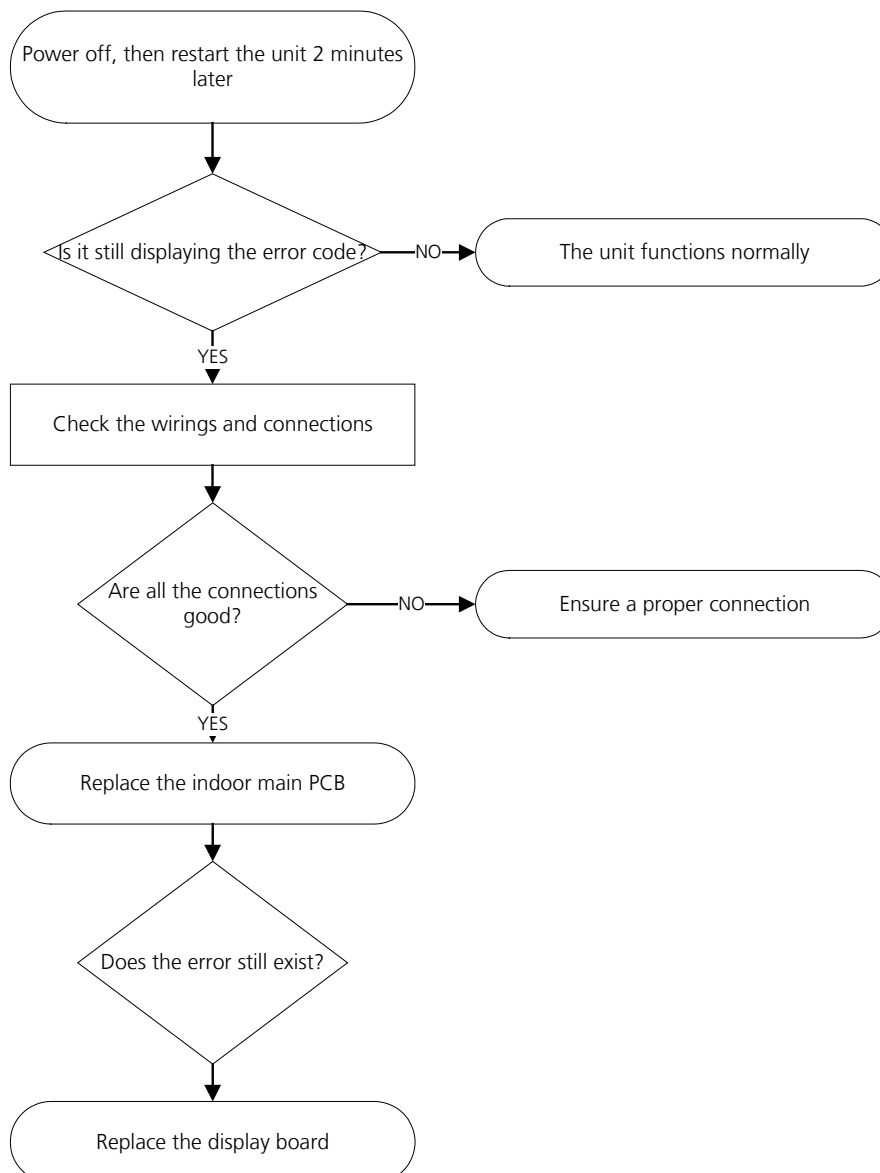

TS08-S: Current overload protection diagnosis and solution

Description: An abnormal current rise is detected by checking the specified current detection circuit.

Recommended parts to prepare:

- Connection wires
- Reactor
- Outdoor fan
- Outdoor PCB

Troubleshooting and repair:

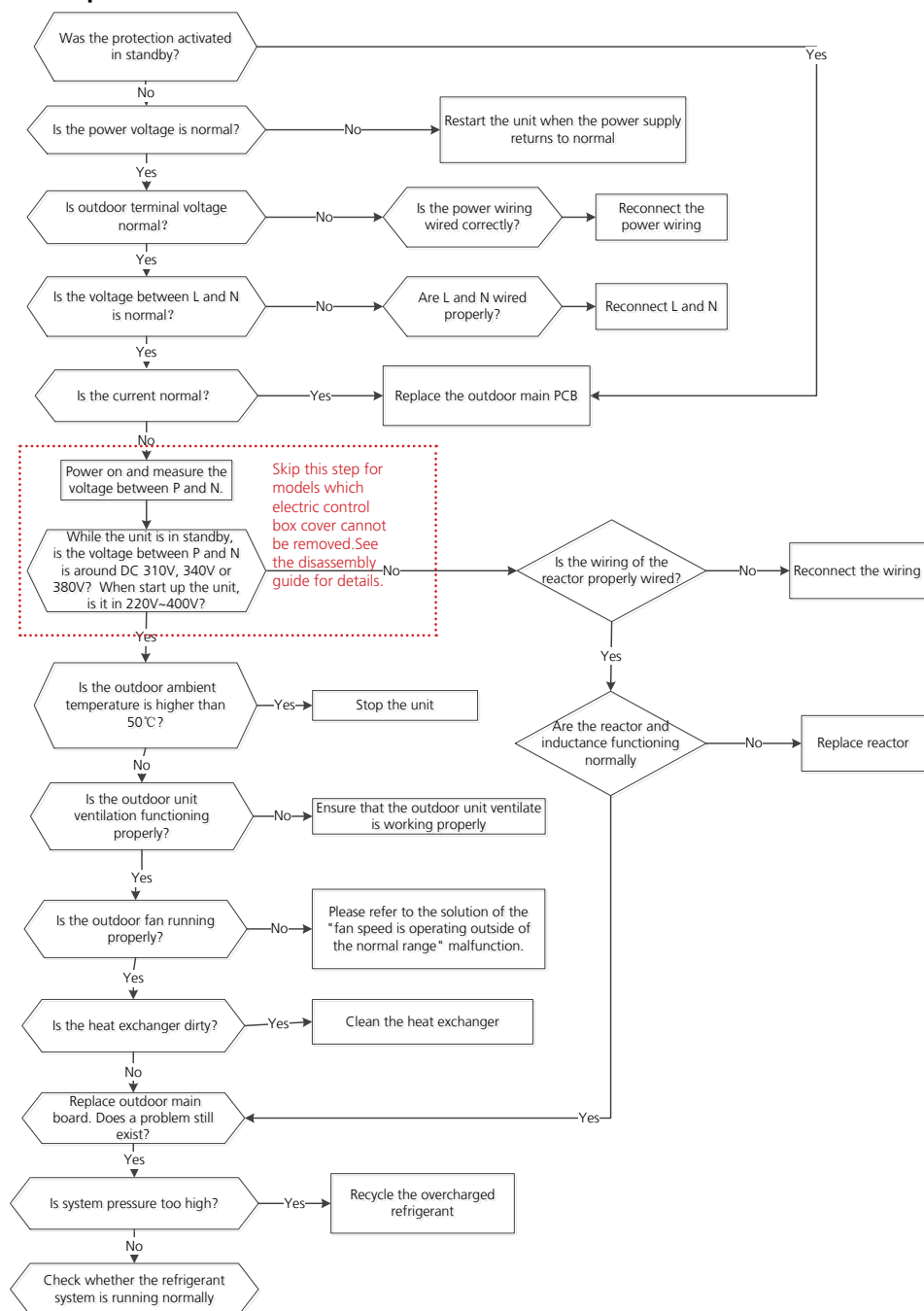

Note: For certain models, outdoor PCB could not be removed separately. In this case, the outdoor electric control box should be replaced as a whole.

TS09-S: IPM malfunction or IGBT over-strong current protection diagnosis and solution

Description: When the voltage signal the IPM sends to the compressor drive chip is abnormal, the LED displays the failure code and the AC turns off.

Recommended parts to prepare:

- Connection wires
- IPM module board
- Outdoor fan assembly
- Compressor
- Outdoor PCB

Troubleshooting and repair:

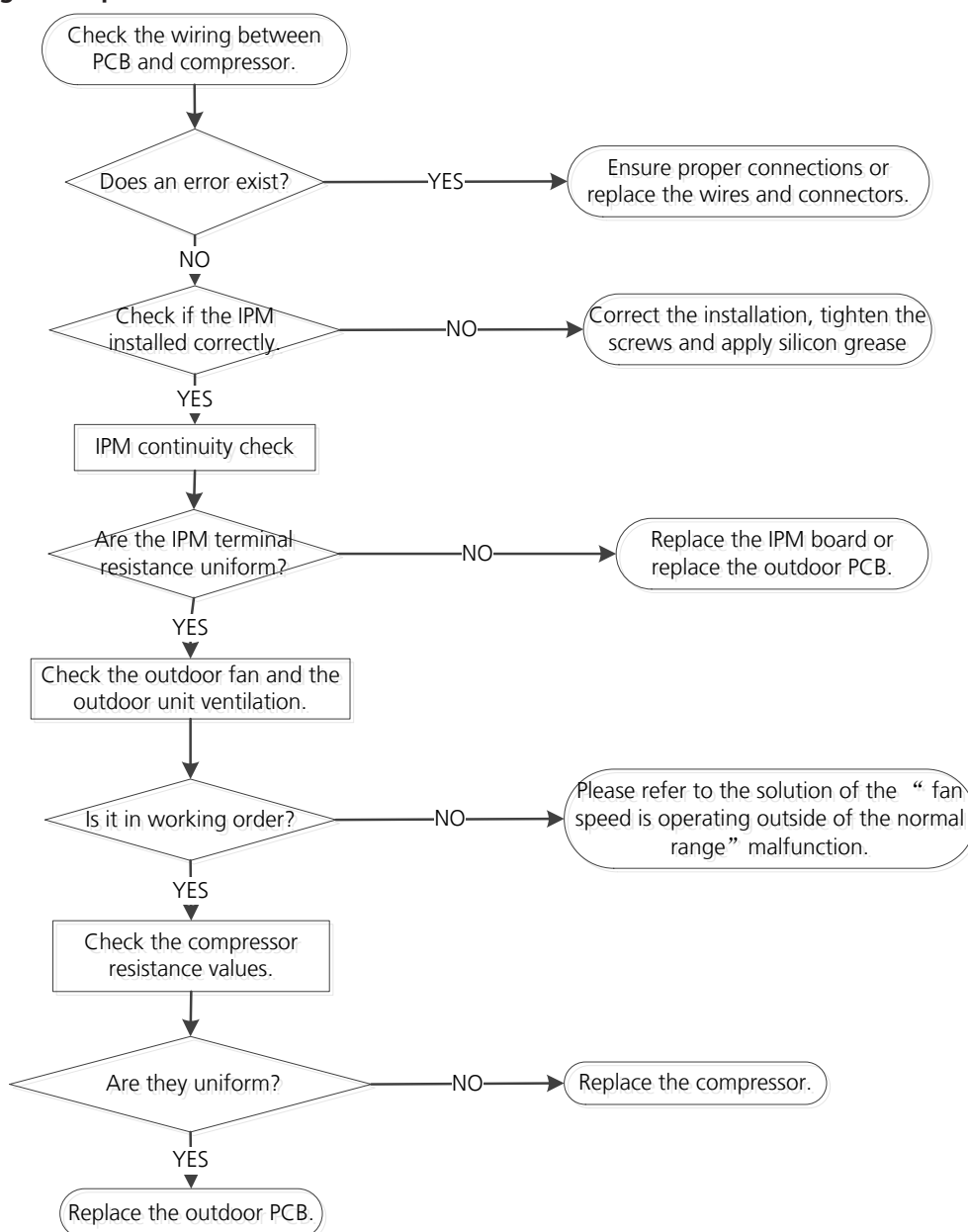

Note: For certain models, outdoor PCB could not be removed separately. In this case, the outdoor electric control box should be replaced as a whole.

TS10-S: Over voltage or too low voltage protection diagnosis and solution

Description: Abnormal increases or decreases in voltage are detected by checking the specified voltage detection circuit.

Recommended parts to prepare:

- Power supply wires
- IPM module board
- PCB
- Reactor

Troubleshooting and repair:

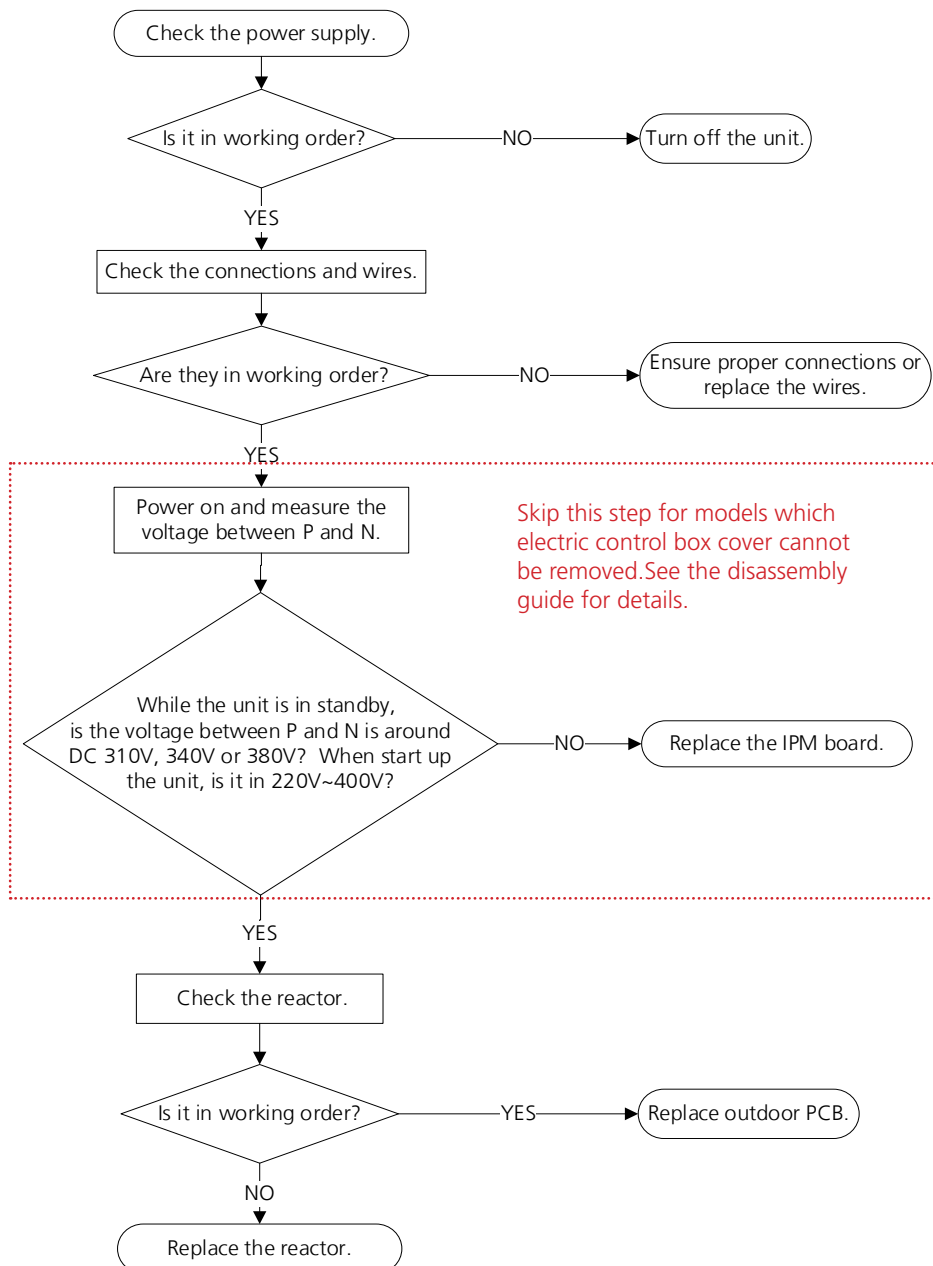

Note: For certain models, outdoor PCB could not be removed separately. In this case, the outdoor electric control box should be replaced as a whole.

TS11-S-INV: Top temperature protection of compressor or High temperature protection of IPM module or High pressure protection diagnosis and solution

Description: For some models with overload protection, If the sampling voltage is not 5V, the LED will display the failure. If the temperature of IPM module is higher than a certain value, the LED displays the failure code.

For some models with high pressure switch, outdoor pressure switch cut off the system because high pressure is higher than 4.4 MPa, the LED displays the failure code.

Recommended parts to prepare:

- Connection wires
- Outdoor PCB
- IPM module board
- High pressure protector
- System blockages

Troubleshooting and repair:

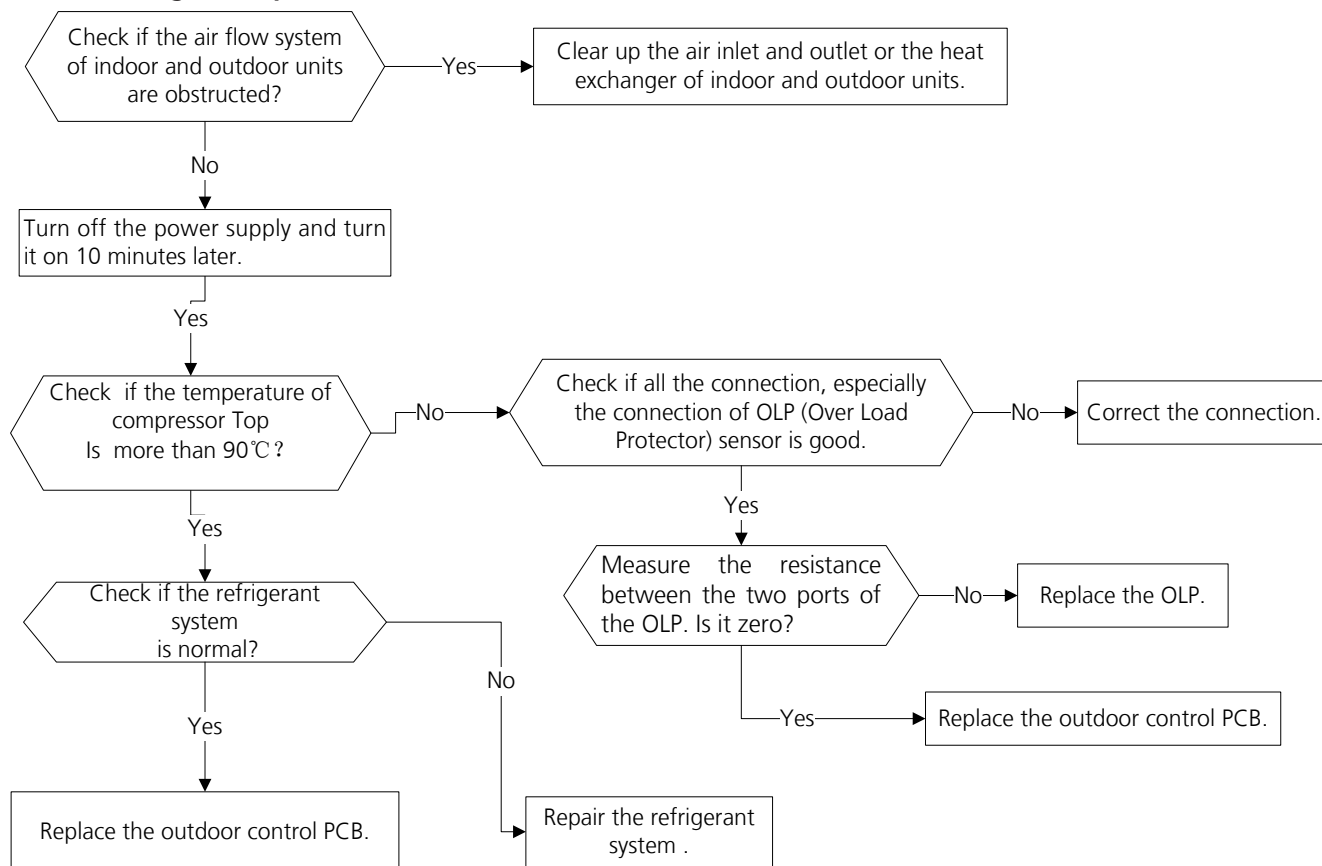

Note: For certain models, outdoor PCB could not be removed separately. In this case, the outdoor electric control box should be replaced as a whole.

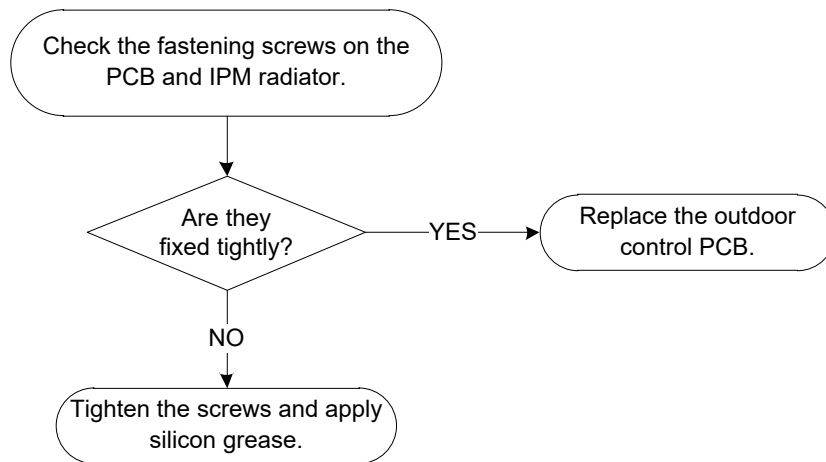

Note: For certain models, outdoor PCB could not be removed separately. In this case, the outdoor electric control box should be replaced as a whole.

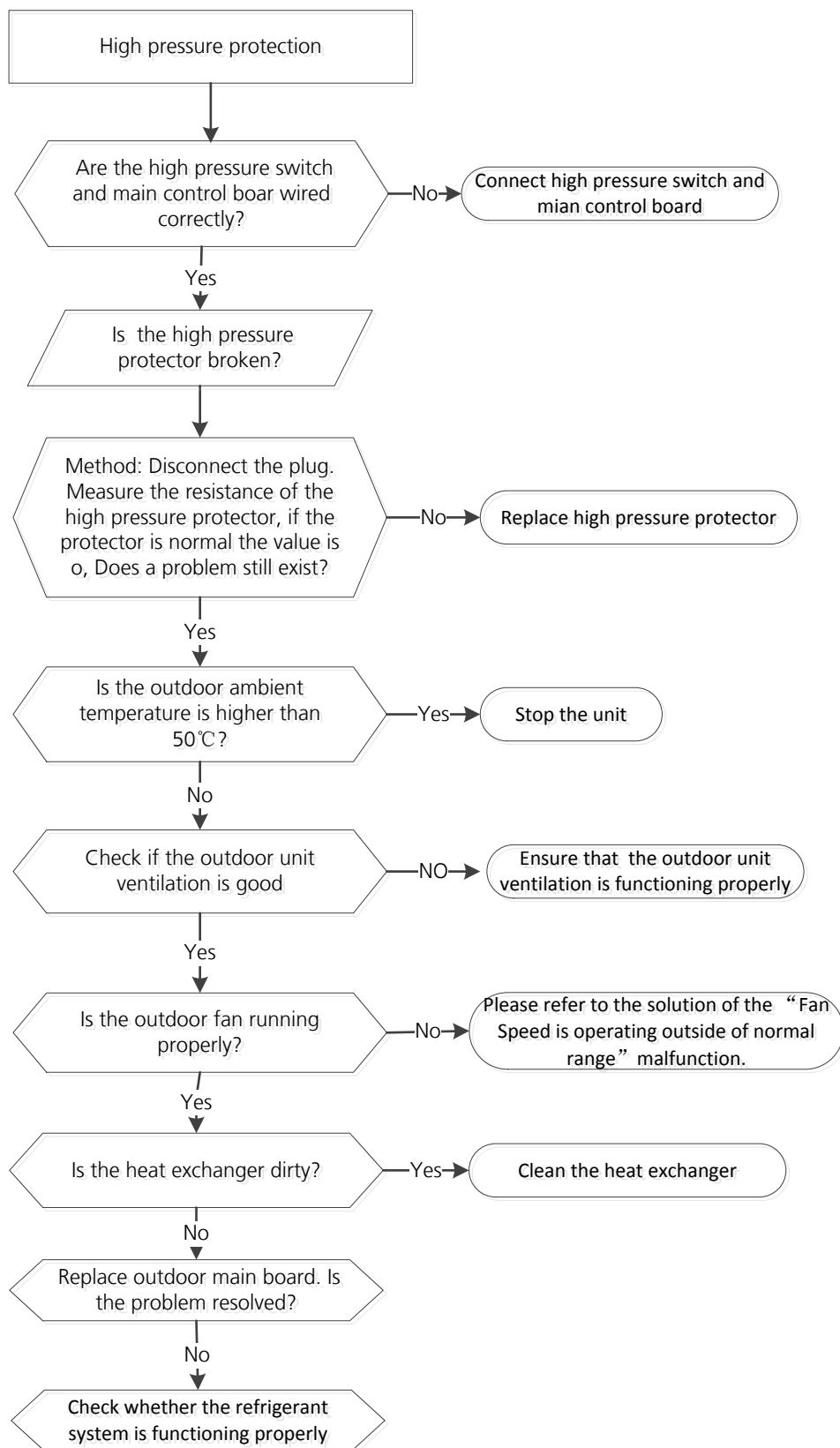

Note: For certain models, outdoor PCB could not be removed separately. In this case, the outdoor electric control box should be replaced as a whole.

TS12-S: Inverter compressor drive error diagnosis and solution

Description: An abnormal inverter compressor drive is detected by a special detection circuit, including communication signal detection, voltage detection, compressor rotation speed signal detection and so on.

Recommended parts to prepare:

- Connection wires
- IPM module board
- Outdoor fan assembly
- Compressor
- Outdoor PCB

Troubleshooting and repair:

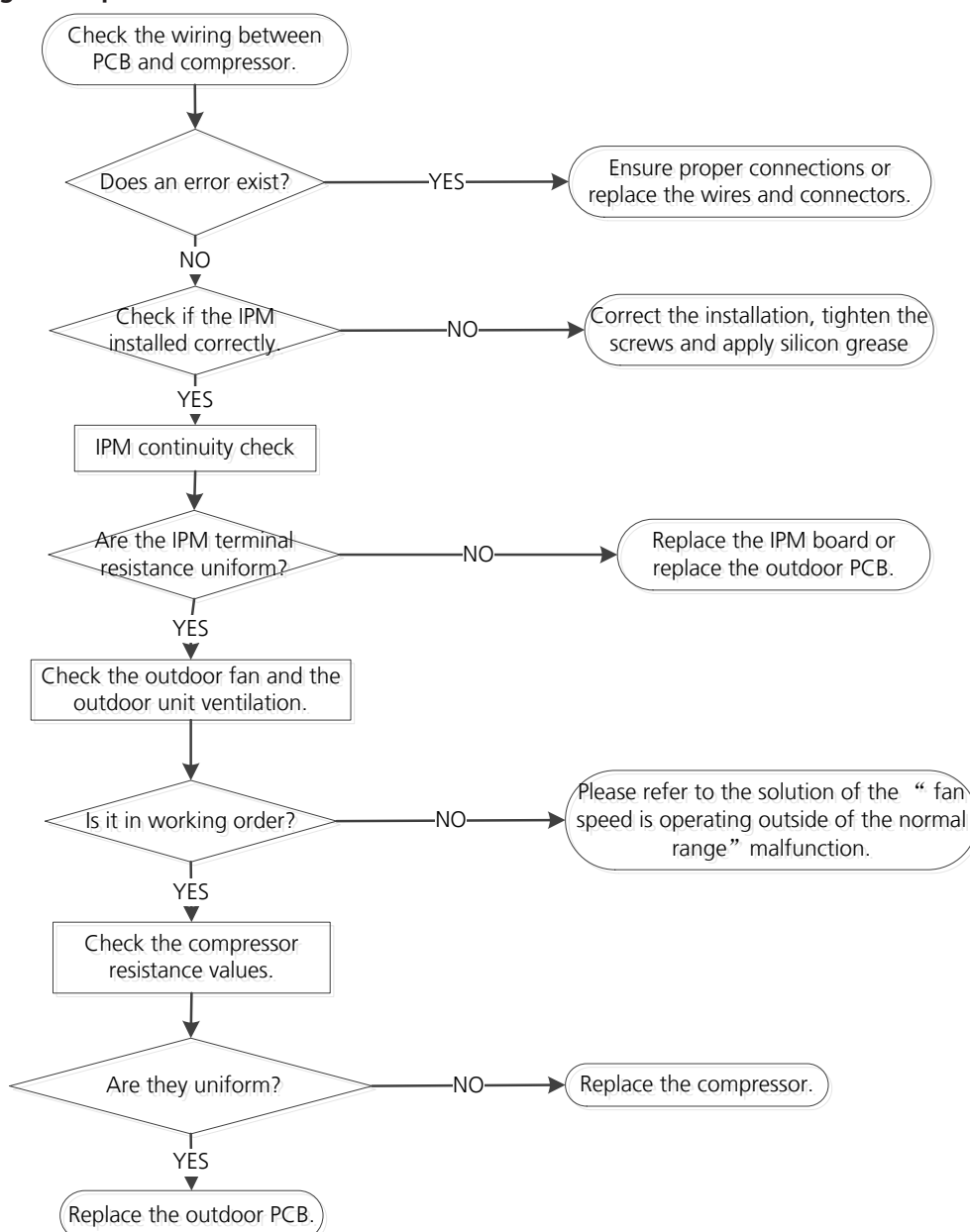

Note: For certain models, outdoor PCB could not be removed separately. In this case, the outdoor electric control box should be replaced as a whole.

TS26-INV: High pressure protection or Low pressure protection diagnosis and solution

Description: Outdoor pressure switch cut off the system because high pressure is higher than 4.4 MPa or outdoor pressure switch cut off the system because low pressure is lower than 0.13 MPa, the LED displays the failure code.

Recommended parts to prepare:

- Connection wires
- Outdoor PCB
- Refrigerant
- Pressure switch
- Outdoor fan

Troubleshooting and repair:

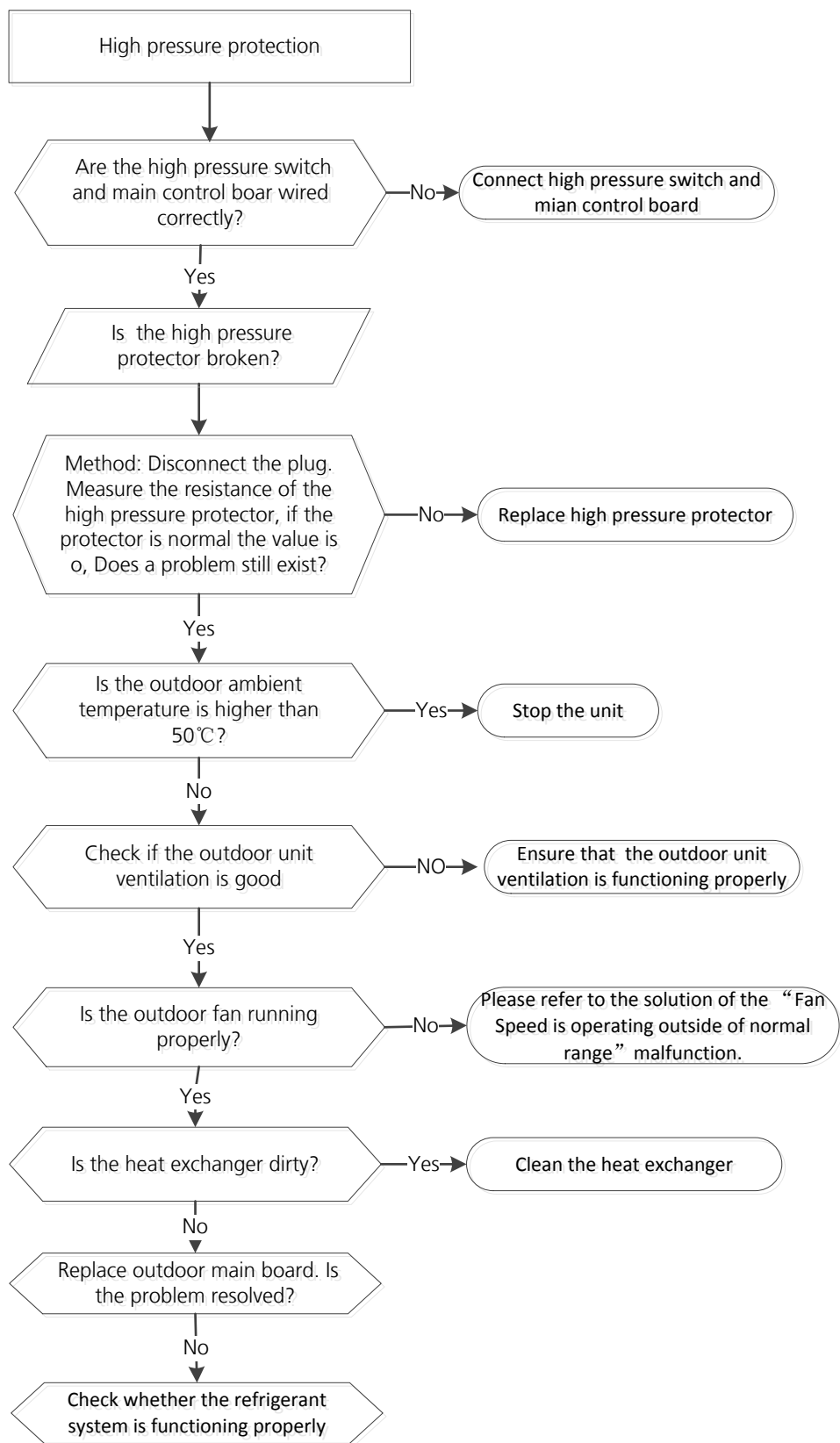

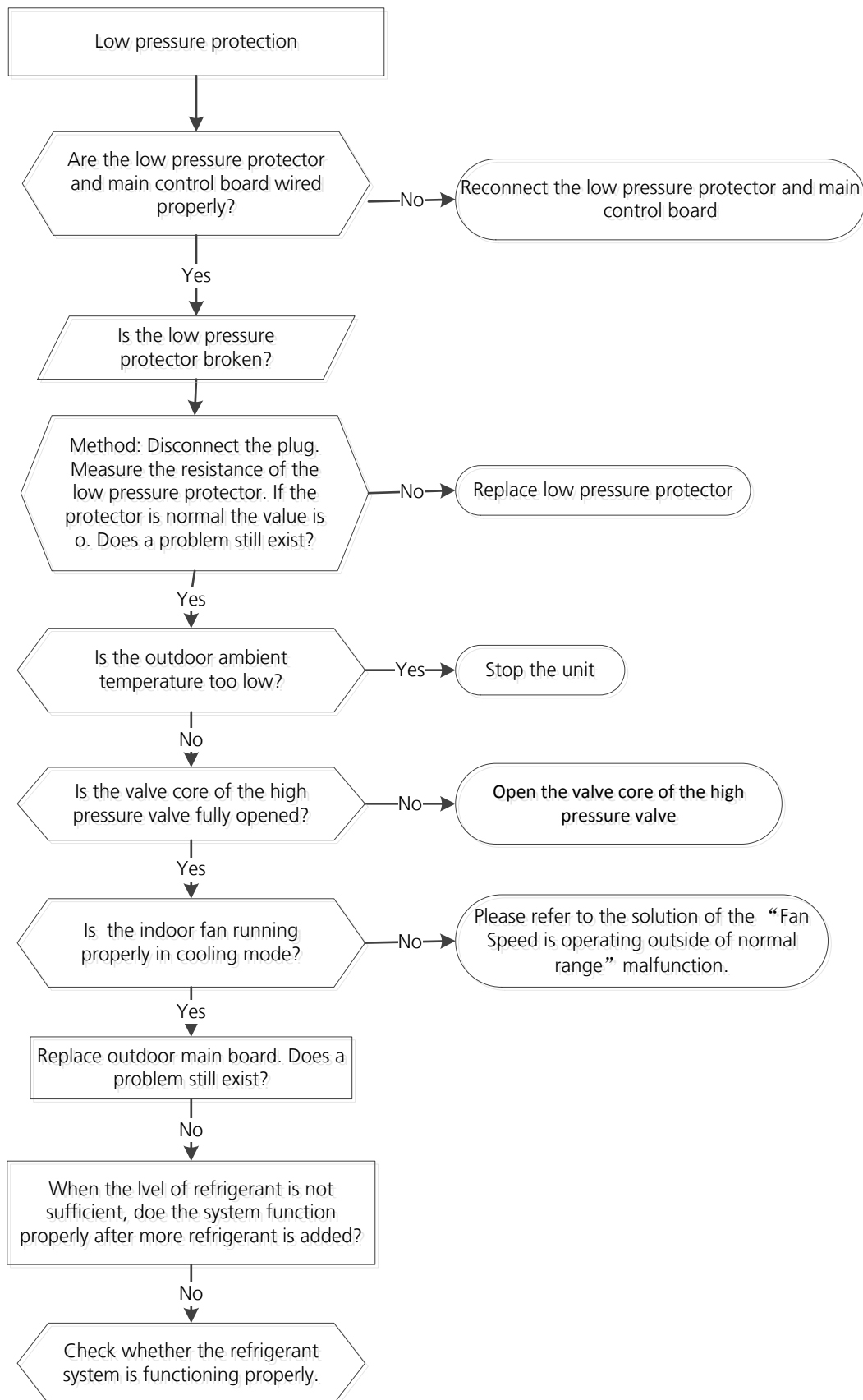

Note: For certain models, outdoor PCB could not be removed separately. In this case, the outdoor electric control box should be replaced as a whole.

TS14: Indoor units mode conflict (match with multi outdoor unit)

Description: The indoor units cannot work cooling mode and heating at same time. Heating mode has a priority.

- Suppose Indoor unit A working in cooling mode or fan mode, and indoor unit B is set to heating mode, then A will change to off and B will work in heating mode.
- Suppose Indoor unit A working in heating mode, and indoor unit B is set to cooling mode or fan mode, then B will change to stand by and A will be no change.

	Cooling mode	Heating Mode	Fan	Off
Cooling mode	No	Yes	No	No
Heating Mode	Yes	No	Yes	No
Fan	No	Yes	No	No
Off	No	No	No	No

Note:

No: No mode conflict

Yes: Mode conflict

TS34: AP mode is active but there is no WIFI kit installed

Description: AP mode is active but cannot detect WIFI kit.

Recommended parts to prepare:

- WIFI kit

Troubleshooting and repair:

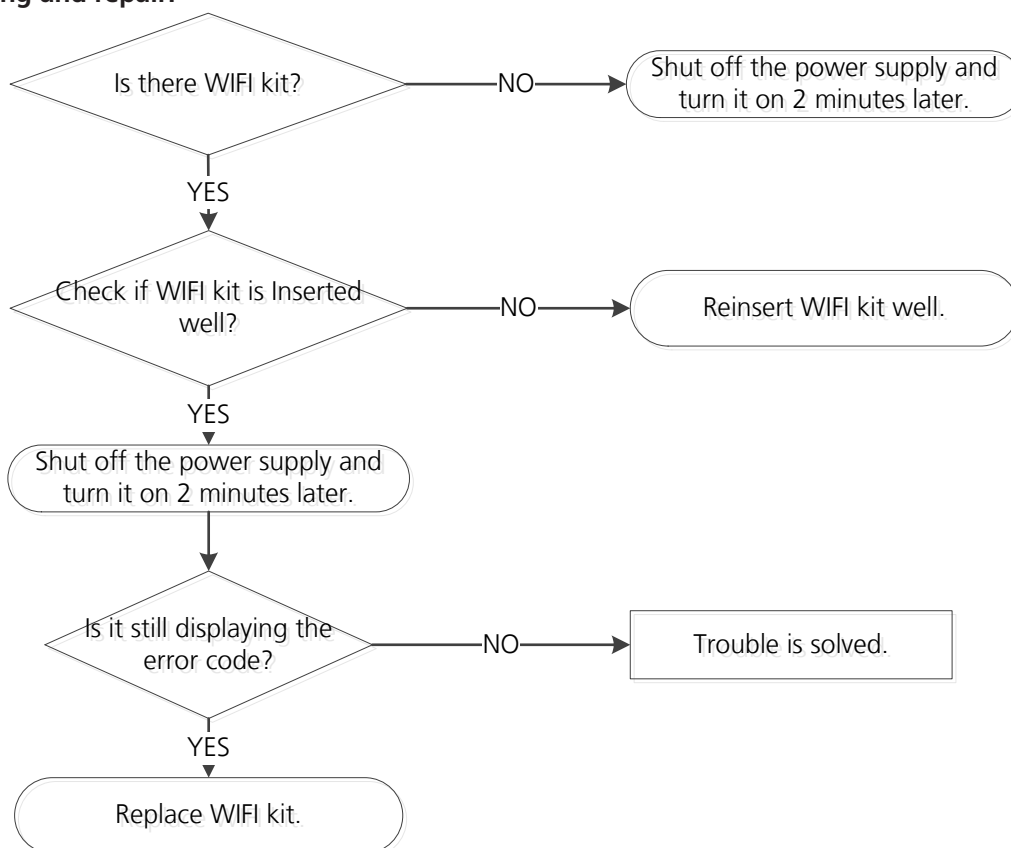

8. Check Procedures

8.1 Temperature Sensor Check

WARNING

Be sure to turn off all power supplies or disconnect all wires to avoid electric shock. Operate after compressor and coil have returned to normal temperature in case of injury.

1. Disconnect the temperature sensor from PCB (Refer to Chapter 5&6. Indoor&Outdoor Unit Disassembly).
2. Measure the resistance value of the sensor using a multi-meter.
3. Check corresponding temperature sensor resistance value table (Refer to Chapter 8. Appendix).

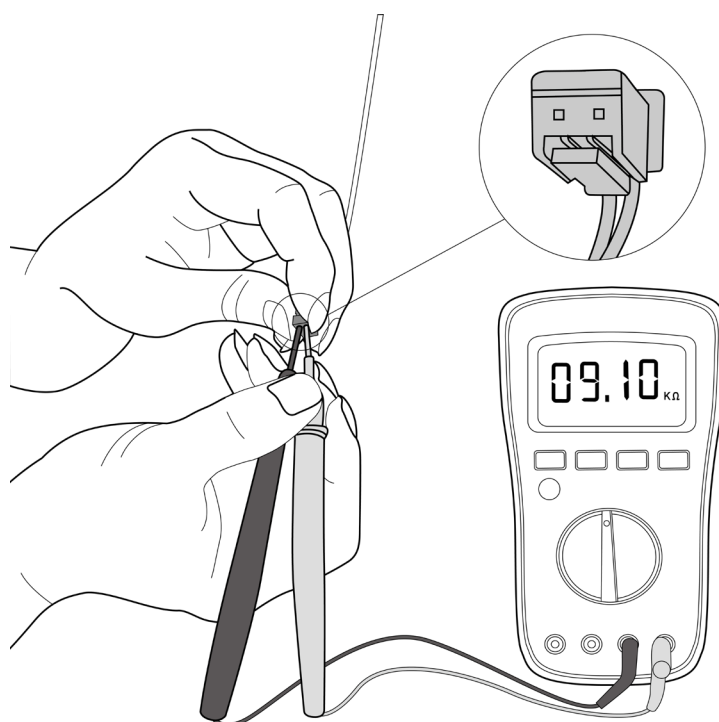

Note: The picture and the value are only for reference, actual condition and specific value may vary.

.2 Compressor Check

1. Disconnect the compressor power cord from outdoor PCB (Refer to Chapter 6. Outdoor Unit Disassembly).
2. Measure the resistance value of each winding using a multi-meter.
3. Check the resistance value of each winding in the following table.

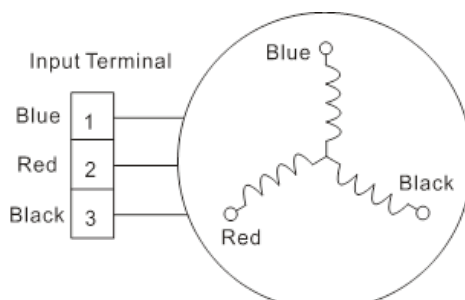

Resistance Value	KSK89D53UEZ	KSK89D29UEZD	KSN98D22UFZ	KSK103D33UEZ3 KSK103D33UEZ3(MD) KBK103D33UEZ3	KSK103D32UEZ31	KTN150D30UFZA
Blue-Red	2.35Ω	1.99Ω	1.57Ω	2.13Ω	4.06Ω	1.02Ω
Blue-Black						
Red-Black						

Resistance Value	KSM135D23UFZ	KTN110D42UFZ	KSN140D21UFZ	KTM140D78UFZ3	KTF235D22UMT ATF235D22TMT KTF250D22UMT	KTM240D46UKT2	KTM240D57UMT
Blue-Red	1.72Ω	1.82Ω	1.28Ω	1.5Ω	0.75Ω	1.04Ω	0.62Ω
Blue-Black							
Red-Black							

Resistance Value	KSN140D58UFZ	KTM240D43UKT	KSN98D64UFZ3	ASN140D35TFZ	KTF420D62UNT	ASN108D22TEZ	DTN210D32UFZ
Blue-Red	1.86Ω	1.03Ω	2.7Ω	0.83Ω	0.86Ω	1.76Ω	1.7Ω
Blue-Black							
Red-Black							

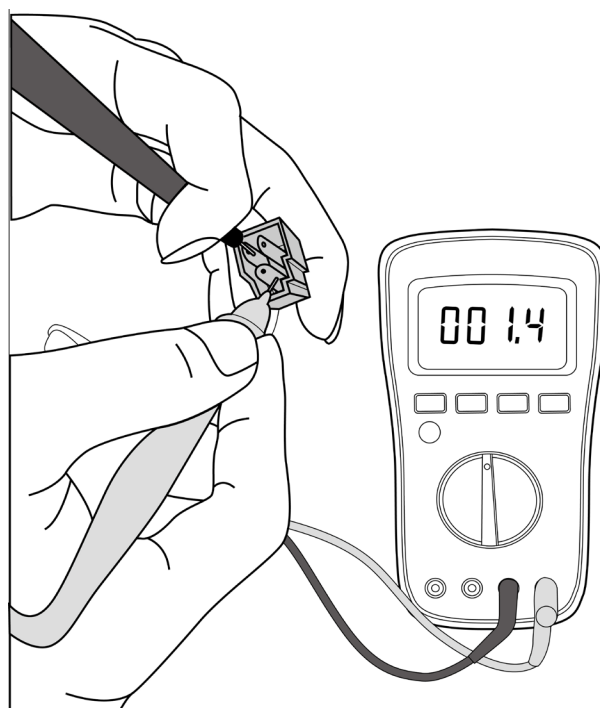

Note: The picture and the value are only for reference, actual condition and specific value may vary.

8.3 IPM Continuity Check

WARNING

**Electricity remains in capacitors even when the power supply is off.
Ensure the capacitors are fully discharged before troubleshooting.**

1. Turn off outdoor unit and disconnect power supply.
2. Discharge electrolytic capacitors and ensure all energy-storage unit has been discharged.
3. Disassemble outdoor PCB or disassemble IPM board.
4. Measure the resistance value between P and U(V, W, N); U(V, W) and N.

Digital tester		Resistance value	Digital tester		Resistance value
(+)Red	(-)Black	∞ (Several MΩ)	(+)Red	(-)Black	∞ (Several MΩ)
P	N		N	U	
	U			V	
	V			W	
	W			-	

Or test the conductivity of IPM with diode mode.

Needle-type Tester		Normal Value	Needle-type Tester		Normal Value
Red	Black		Red	Black	
P	U	Open-circuit	N	U	0.3-0.5V
	V			V	
	W			W	
Needle-type Tester		Normal Value	Needle-type Tester		Normal Value
Black	Red		Black	Red	
P	U	0.3-0.5V	N	U	Open-circuit
	V			V	
	W			W	

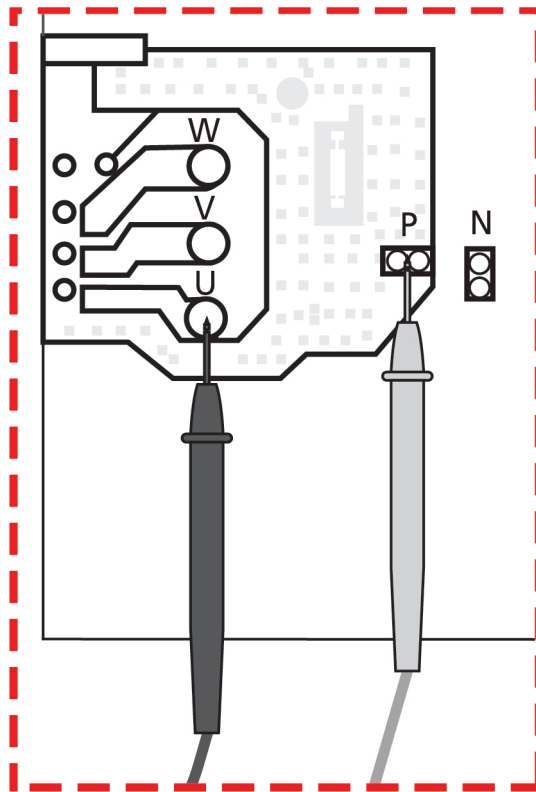

Note: The picture and the value are only for reference, actual condition and specific value may vary.

8.4 4-way Valve Check

1. Power on, use a digital tester to measure the voltage, when the unit operates in cooling, it is 0V. When the unit operates in heating, it is about 230VAC.

If the value of the voltage is not in the range, the PCB must have problems and need to be replaced.

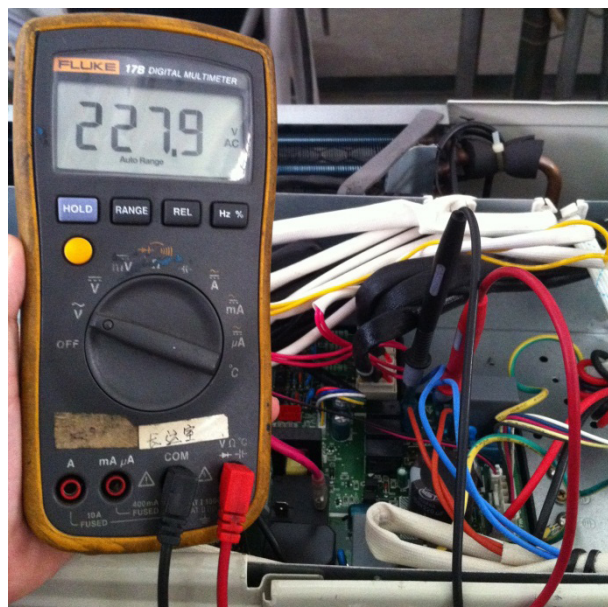

2 Turn off the power, use a digital tester to measure the resistance. The value should be 1.8~2.5 K Ω .

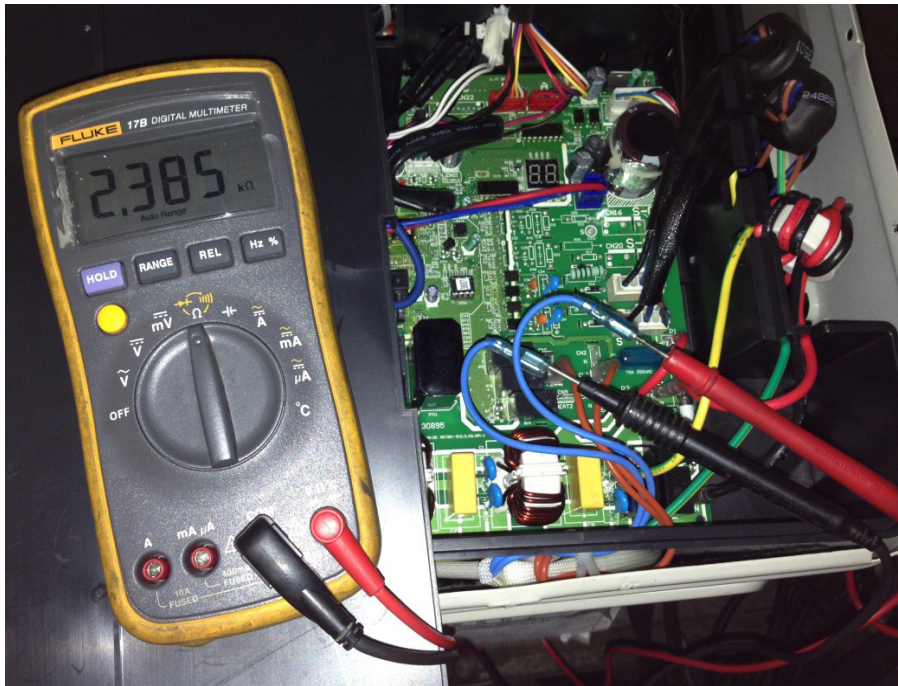

8.5 EXV Check

WARNING

**Electricity remains in capacitors even when the power supply is off.
Ensure the capacitors are fully discharged before troubleshooting.**

1. Disconnect the connector from outdoor PCB.
2. Measure the resistance value of each winding using a multi-meter.
3. Check the resistance value of each winding in the following table.

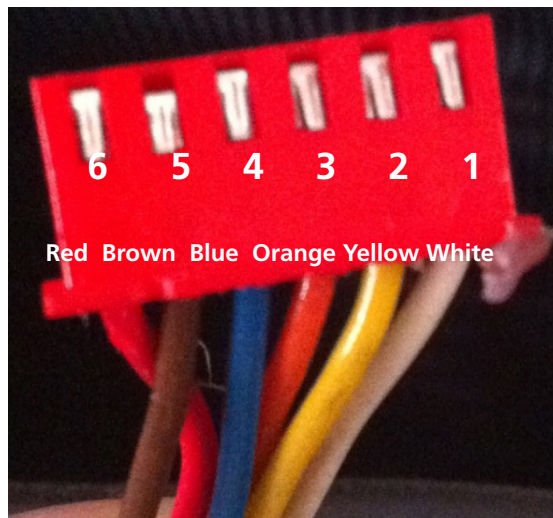

Color of lead winding	Normal Value
Red- Blue	About 50Ω
Red - Yellow	
Brown-Orange	
Brown-White	

Appendix

Contents

i)	Temperature Sensor Resistance Value Table for T1, T2, T3, and T4 (°C – K)	2
ii)	Temperature Sensor Resistance Value Table for TP (for some units)(°C --K)	3
iii)	Pressure On Service Port	4

i) Temperature Sensor Resistance Value Table for T1,T2,T3 and T4 (°C – K)

°C	°F	K Ohm	°C	°F	K Ohm	°C	°F	K Ohm	°C	°F	K Ohm
-20	-4	115.266	20	68	12.6431	60	140	2.35774	100	212	0.62973
-19	-2	108.146	21	70	12.0561	61	142	2.27249	101	214	0.61148
-18	0	101.517	22	72	11.5	62	144	2.19073	102	216	0.59386
-17	1	96.3423	23	73	10.9731	63	145	2.11241	103	217	0.57683
-16	3	89.5865	24	75	10.4736	64	147	2.03732	104	219	0.56038
-15	5	84.219	25	77	10	65	149	1.96532	105	221	0.54448
-14	7	79.311	26	79	9.55074	66	151	1.89627	106	223	0.52912
-13	9	74.536	27	81	9.12445	67	153	1.83003	107	225	0.51426
-12	10	70.1698	28	82	8.71983	68	154	1.76647	108	226	0.49989
-11	12	66.0898	29	84	8.33566	69	156	1.70547	109	228	0.486
-10	14	62.2756	30	86	7.97078	70	158	1.64691	110	230	0.47256
-9	16	58.7079	31	88	7.62411	71	160	1.59068	111	232	0.45957
-8	18	56.3694	32	90	7.29464	72	162	1.53668	112	234	0.44699
-7	19	52.2438	33	91	6.98142	73	163	1.48481	113	235	0.43482
-6	21	49.3161	34	93	6.68355	74	165	1.43498	114	237	0.42304
-5	23	46.5725	35	95	6.40021	75	167	1.38703	115	239	0.41164
-4	25	44	36	97	6.13059	76	169	1.34105	116	241	0.4006
-3	27	41.5878	37	99	5.87359	77	171	1.29078	117	243	0.38991
-2	28	39.8239	38	100	5.62961	78	172	1.25423	118	244	0.37956
-1	30	37.1988	39	102	5.39689	79	174	1.2133	119	246	0.36954
0	32	35.2024	40	104	5.17519	80	176	1.17393	120	248	0.35982
1	34	33.3269	41	106	4.96392	81	178	1.13604	121	250	0.35042
2	36	31.5635	42	108	4.76253	82	180	1.09958	122	252	0.3413
3	37	29.9058	43	109	4.5705	83	181	1.06448	123	253	0.33246
4	39	28.3459	44	111	4.38736	84	183	1.03069	124	255	0.3239
5	41	26.8778	45	113	4.21263	85	185	0.99815	125	257	0.31559
6	43	25.4954	46	115	4.04589	86	187	0.96681	126	259	0.30754
7	45	24.1932	47	117	3.88673	87	189	0.93662	127	261	0.29974
8	46	22.5662	48	118	3.73476	88	190	0.90753	128	262	0.29216
9	48	21.8094	49	120	3.58962	89	192	0.8795	129	264	0.28482
10	50	20.7184	50	122	3.45097	90	194	0.85248	130	266	0.2777
11	52	19.6891	51	124	3.31847	91	196	0.82643	131	268	0.27078
12	54	18.7177	52	126	3.19183	92	198	0.80132	132	270	0.26408
13	55	17.8005	53	127	3.07075	93	199	0.77709	133	271	0.25757
14	57	16.9341	54	129	2.95896	94	201	0.75373	134	273	0.25125
15	59	16.1156	55	131	2.84421	95	203	0.73119	135	275	0.24512
16	61	15.3418	56	133	2.73823	96	205	0.70944	136	277	0.23916
17	63	14.6181	57	135	2.63682	97	207	0.68844	137	279	0.23338
18	64	13.918	58	136	2.53973	98	208	0.66818	138	280	0.22776
19	66	13.2631	59	138	2.44677	99	210	0.64862	139	282	0.22231

ii) Temperature Sensor Resistance Value Table for TP(for some units) (°C --K)

°C	°F	K Ohm	°C	°F	K Ohm	°C	°F	K Ohm	°C	°F	K Ohm
°C	°F	K Ohm	°C	°F	K Ohm	°C	°F	K Ohm	°C	°F	K Ohm
-20	-4	542.7	20	68	68.66	60	140	13.59	100	212	3.702
-19	-2	511.9	21	70	65.62	61	142	13.11	101	214	3.595
-18	0	483	22	72	62.73	62	144	12.65	102	216	3.492
-17	1	455.9	23	73	59.98	63	145	12.21	103	217	3.392
-16	3	430.5	24	75	57.37	64	147	11.79	104	219	3.296
-15	5	406.7	25	77	54.89	65	149	11.38	105	221	3.203
-14	7	384.3	26	79	52.53	66	151	10.99	106	223	3.113
-13	9	363.3	27	81	50.28	67	153	10.61	107	225	3.025
-12	10	343.6	28	82	48.14	68	154	10.25	108	226	2.941
-11	12	325.1	29	84	46.11	69	156	9.902	109	228	2.86
-10	14	307.7	30	86	44.17	70	158	9.569	110	230	2.781
-9	16	291.3	31	88	42.33	71	160	9.248	111	232	2.704
-8	18	275.9	32	90	40.57	72	162	8.94	112	234	2.63
-7	19	261.4	33	91	38.89	73	163	8.643	113	235	2.559
-6	21	247.8	34	93	37.3	74	165	8.358	114	237	2.489
-5	23	234.9	35	95	35.78	75	167	8.084	115	239	2.422
-4	25	222.8	36	97	34.32	76	169	7.82	116	241	2.357
-3	27	211.4	37	99	32.94	77	171	7.566	117	243	2.294
-2	28	200.7	38	100	31.62	78	172	7.321	118	244	2.233
-1	30	190.5	39	102	30.36	79	174	7.086	119	246	2.174
0	32	180.9	40	104	29.15	80	176	6.859	120	248	2.117
1	34	171.9	41	106	28	81	178	6.641	121	250	2.061
2	36	163.3	42	108	26.9	82	180	6.43	122	252	2.007
3	37	155.2	43	109	25.86	83	181	6.228	123	253	1.955
4	39	147.6	44	111	24.85	84	183	6.033	124	255	1.905
5	41	140.4	45	113	23.89	85	185	5.844	125	257	1.856
6	43	133.5	46	115	22.89	86	187	5.663	126	259	1.808
7	45	127.1	47	117	22.1	87	189	5.488	127	261	1.762
8	46	121	48	118	21.26	88	190	5.32	128	262	1.717
9	48	115.2	49	120	20.46	89	192	5.157	129	264	1.674
10	50	109.8	50	122	19.69	90	194	5	130	266	1.632
11	52	104.6	51	124	18.96	91	196	4.849			
12	54	99.69	52	126	18.26	92	198	4.703			
13	55	95.05	53	127	17.58	93	199	4.562			
14	57	90.66	54	129	16.94	94	201	4.426			
15	59	86.49	55	131	16.32	95	203	4.294			
16	61	82.54	56	133	15.73	96	205	4.167			
17	63	78.79	57	135	15.16	97	207	4.045			
18	64	75.24	58	136	14.62	98	208	3.927			
19	66	71.86	59	138	14.09	99	210	3.812			

iii) Pressure On Service Port

Cooling chart(R410A):

°F(°C)	ODU(DB)		0(-17)	5(-15)	15(-9.44)	45(7.22)	75(23.89)	85(29.44)	95(35)	105(40.56)	115(46.11)	120(48.89)
	IDU(DB/WB)											
BAR	70/59 (21.11/15)		6.4	6.5	7.3	8.0	8.2	7.8	8.1	8.6	10.1	10.6
	75/63 (23.89/17.22)		6.7	6.8	7.9	8.6	8.6	8.3	8.7	9.1	10.7	11.2
	80/67 (26.67/19.44)		7.1	7.2	8.5	9.5	9.3	8.9	9.1	9.6	11.2	11.9
	90/73 (32.22/22.78)		7.7	7.8	9.6	10.5	10.3	9.5	10.0	10.6	12.4	13.0
PSI	70/59 (21.11/15)		93	94	106	116	119	113	117	125	147	154
	75/63 (23.89/17.22)		97	99	115	125	124	120	126	132	155	162
	80/67 (26.67/19.44)		103	104	123	138	135	129	132	140	162	173
	90/73 (32.22/22.78)		112	113	139	152	149	138	145	154	180	189
MPa	70/59 (21.11/15)		0.64	0.65	0.73	0.8	0.82	0.78	0.81	0.86	1.01	1.06
	75/63 (23.89/17.22)		0.67	0.68	0.79	0.86	0.86	0.83	0.87	0.91	1.07	1.12
	80/67 (26.67/19.44)		0.71	0.72	0.85	0.95	0.93	0.89	0.91	0.96	1.12	1.19
	90/73 (32.22/22.78)		0.77	0.78	0.96	1.05	1.03	0.95	1	1.06	1.24	1.3

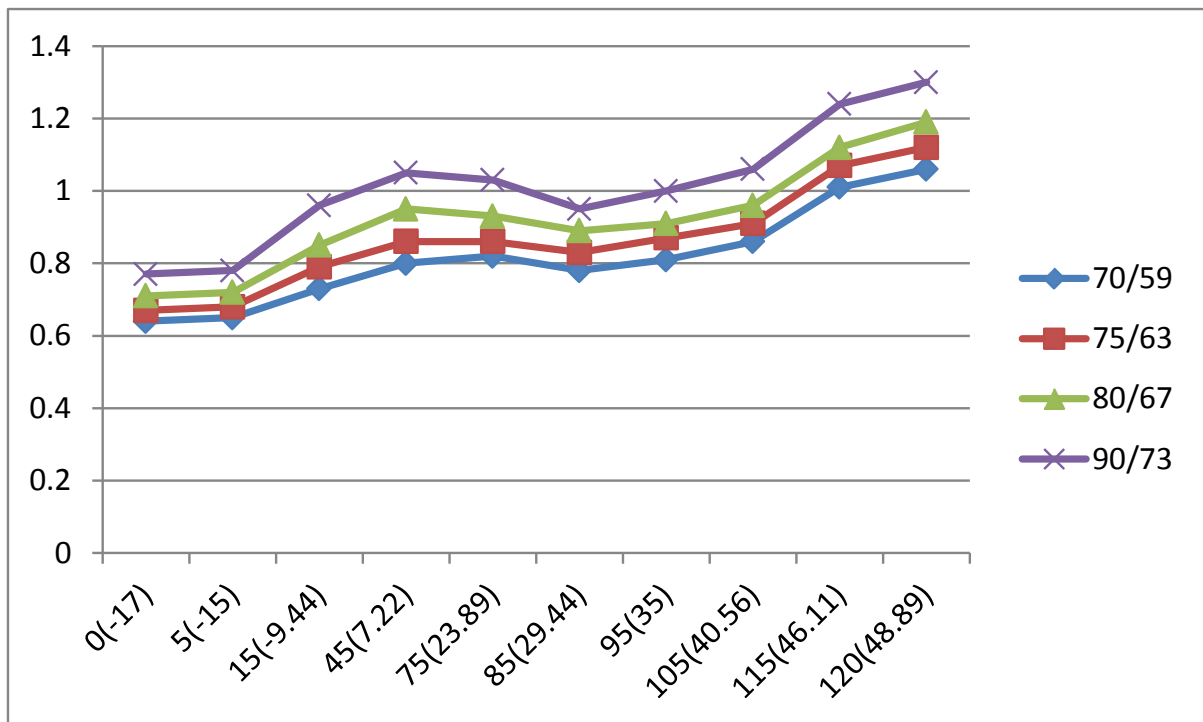

System Pressure Table-R410A

Pressure			Temperature		Pressure			Temperature	
Kpa	bar	PSI	°C	°F	Kpa	bar	PSI	°C	°F
100	1	14.5	-51.623	-60.921	2350	23.5	340.75	38.817	101.871
150	1.5	21.75	-43.327	-45.989	2400	24	348	39.68	103.424
200	2	29	-36.992	-34.586	2450	24.5	355.25	40.531	104.956
250	2.5	36.25	-31.795	-25.231	2500	25	362.5	41.368	106.462
300	3	43.5	-27.351	-17.232	2550	25.5	369.75	42.192	107.946
350	3.5	50.75	-23.448	-10.206	2600	26	377	43.004	109.407
400	4	58	-19.953	-3.915	2650	26.5	384.25	43.804	110.847
450	4.5	65.25	-16.779	1.798	2700	27	391.5	44.592	112.266
500	5	72.5	-13.863	7.047	2750	27.5	398.75	45.37	113.666
550	5.5	79.75	-11.162	11.908	2800	28	406	46.136	115.045
600	6	87	-8.643	16.444	2850	28.5	413.25	46.892	116.406
650	6.5	94.25	-6.277	20.701	2900	29	420.5	47.638	117.748
700	7	101.5	-4.046	24.716	2950	29.5	427.75	48.374	119.073
750	7.5	108.75	-1.933	28.521	3000	30	435	49.101	120.382
800	8	116	0.076	32.137	3050	30.5	442.25	49.818	121.672
850	8.5	123.25	1.993	35.587	3100	31	449.5	50.525	122.945
900	9	130.5	3.826	38.888	3150	31.5	456.75	51.224	124.203
950	9.5	137.75	5.584	42.052	3200	32	464	51.914	125.445
1000	10	145	7.274	45.093	3250	32.5	471.25	52.596	126.673
1050	10.5	152.25	8.901	48.022	3300	33	478.5	53.27	127.886
1100	11	159.5	10.471	50.848	3350	33.5	485.75	53.935	129.083
1150	11.5	166.75	11.988	53.578	3400	34	493	54.593	130.267
1200	12	174	13.457	56.223	3450	34.5	500.25	55.243	131.437
1250	12.5	181.25	14.879	58.782	3500	35	507.5	55.885	132.593
1300	13	188.5	16.26	61.268	3550	35.5	514.75	56.52	133.736
1350	13.5	195.75	17.602	63.684	3600	36	522	57.148	134.866
1400	14	203	18.906	66.031	3650	36.5	529.25	57.769	135.984
1450	14.5	210.25	20.176	68.317	3700	37	536.5	58.383	137.089
1500	15	217.5	21.414	70.545	3750	37.5	543.75	58.99	138.182
1550	15.5	224.75	22.621	72.718	3800	38	551	59.591	139.264
1600	16	232	23.799	74.838	3850	38.5	558.25	60.185	140.333
1650	16.5	239.25	24.949	76.908	3900	39	565.5	60.773	141.391
1700	17	246.5	26.074	78.933	3950	39.5	572.75	61.355	142.439
1750	17.5	253.75	27.174	80.913	4000	40	580	61.93	143.474
1800	18	261	28.251	82.852	4050	40.5	587.25	62.499	144.498
1850	18.5	268.25	29.305	84.749	4100	41	594.5	63.063	145.513
1900	19	275.5	30.338	86.608	4150	41.5	601.75	63.62	146.516
1950	19.5	282.75	31.351	88.432	4200	42	609	64.172	147.510
2000	20	290	32.344	90.219	4250	42.5	616.25	64.719	148.494
2050	20.5	297.25	33.319	91.974	4300	43	623.5	65.259	149.466
2100	21	304.5	34.276	93.697	4350	43.5	630.75	65.795	150.431
2150	21.5	311.75	35.215	95.387	4400	44	638	66.324	151.383
2200	22	319	36.139	97.050	4450	44.5	645.25	66.849	152.328
2250	22.5	326.25	37.047	98.685	4500	45	652.5	67.368	153.262
2300	23	333.5	37.939	100.290					