

SUBMITTAL DATA SHEET



CAC18CD

Location: _____	Approval: _____
Engineer: _____	Date: _____
Submitted to: _____	Construction: _____
Submitted by: _____	Unit #: _____
Reference: _____	Drawing #: _____

Set Model
 Indoor unit model CAC18CD(I)
 Outdoor unit model CAC18CD(O)

Certified **AHRI**



SYSTEM PERFORMANCE DATA

Power supply	V-Ph-Hz	220_230V, 1Ph, 60HZ
Cooling Capacity	Btu/h	18000
Input	W	1500
Current	A	6.7
EER	W/W	3.52
EER2	BUT/W	11.5
AHRI-SEER2	BUT/W	22.0
Rated Power Input	W	3000
Rated Current	A	14.0

INDOOR UNIT DATA

Indoor fan motor		
Model		ZKFP-30-8-297L
Input	W	/
Capacitor	uF	/
Speed(Hi/Mi/Lo)	r/min	1250/900/750
Indoor air flow (Hi/Mi/Lo)	m3/h	800/600/520
	CFM	471/353/306
Indoor noise level (Hi/Mi/Lo)	dB(A)	45/40/30
Indoor unit Dimension(W*D*H)	mm	971x228x321
	inch	38.2x9.0x12.6
Indoor unit Packing (W*D*H)	mm	1045x305x405
	inch	41.1x12.0x15.9
Indoor unit Net/Gross weight	kg	11.0/14.8
	lbs	24.3/32.63

REFRIGERANT PIPE DATA

Compressor		
Model		KSK103D33UEZ3
Type		ROTARY
Brand		GMCC
Capacity	W	2035/3255
Input	W	325/826
Rated current(RLA)	A	2.40/5.65
Refrigerant oil/oil charge	ml	ESTER OIL VG74 310
Refrigerant piping		
Liquid side/ Gas side	mm(inch)	6.35mm(1/4in)/12.7mm(1/2in)
Max. refrigerant pipe length	m	30
	inch	1181
Max. difference in level	m	20
	inch	787
Connection wiring		16#x4
Operation temperature	°C	17~30
	°F	63~86
Indoor temperature	°C	16~32
	°F	63~90
Outdoor temperature	°C	0~50
	°F	34~122
Application area (Cooling Standar	m ²	24~35
	ft ²	258.2~376.6

OUTDOOR UNIT DATA

Outdoor fan motor		
Model		ZKFN-25-10-5L
Input	W	/
Capacitor	uF	/
Speed	r/min	810/450
Outdoor air flow	m3/h	2100
	CFM	1235
Outdoor noise level	dB(A)	54
Outdoor unit Dimension(W*D*H)	mm	765x303x555
	inch	30.1x11.9x21.9
Outdoor unit Packing (W*D*H)	mm	885x375x605
	inch	34.84x14.76x23.82
Outdoor unit Net/Gross weight	kg	23.5/27.6
	lbs	51.9/60.85

Indoor unit dimension

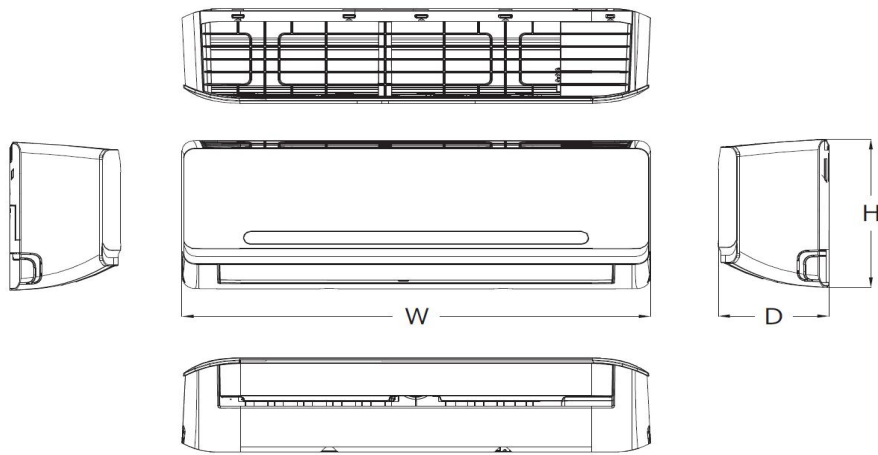

(The figure is for reference only)

Dimension(inch)	W	D	H
CAC12CA(I)	31.6	7.9	11.6
CAC12CD(I)	31.6	7.9	11.6
CAC18CD(I)	38.2	9.0	12.6
CAC24CD(I)	42.6	9.2	13.3

Outdoor unit dimension

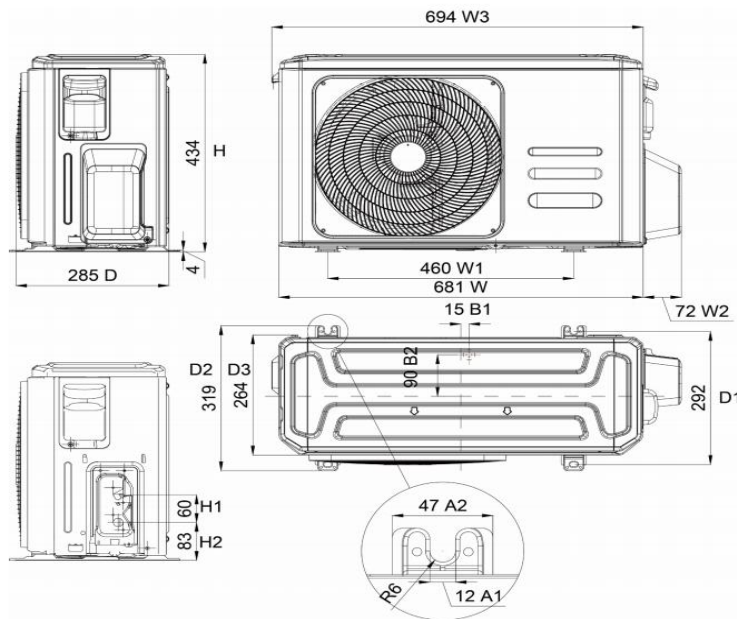

(The figure is for reference only)

Dimension(inch)	W	D	H
CAC12CA(O)	28.3	10.6	19.5
CAC12CD(O)	28.3	10.6	19.5
CAC18CD(O)	30.1	11.9	21.9
CAC24CD(O)	31.7	13.0	21.8