

# SUBMITTAL DATA SHEET



## CAC24CD

Location: \_\_\_\_\_  
 Engineer: \_\_\_\_\_  
 Submitted to: \_\_\_\_\_  
 Submitted by: \_\_\_\_\_  
 Reference: \_\_\_\_\_

Approval: \_\_\_\_\_  
 Date: \_\_\_\_\_  
 Construction: \_\_\_\_\_  
 Unit #: \_\_\_\_\_  
 Drawing #: \_\_\_\_\_

**Set Model**  
 Indoor unit model                   CAC24CD(I)  
 Outdoor unit model               CAC24CD(O)

**Certified**                            **AHRI** 



## SYSTEM PERFORMANCE DATA

Power supply	V-Ph-Hz	220_230V, 1Ph, 60HZ
Cooling Capacity	Btu/h	22000
Input	W	2000
Current	A	9.0
EER	W/W	3.22
EER2	BUT/W	11.5
AHRI-SEER2	BUT/W	20.5
Rated Power Input	W	3450
Rated Current	A	16.0

## INDOOR UNIT DATA

<b>Indoor fan motor</b>		
Model		ZKFP-58-8-20L
Input	W	/
Capacitor	uF	/
Speed(Hi/Mi/Lo)	r/min	1150/1030/970
Indoor air flow (Hi/Mi/Lo)	m3/h	1000/800/680
	CFM	588/471/400
Indoor noise level (Hi/Mi/Lo)	dB(A)	48/41/33
Indoor unit Dimension(W*D*H)	mm	1082x234x337
	inch	42.6x9.2x13.3
Indoor unit Packing (W*D*H)	mm	1155x415x315
	inch	45.5x16.3x12.4
Indoor unit Net/Gross weight	kg	13.3/17.4
	lbs	29.3/38.36

## REFRIGERANT PIPE DATA

<b>Compressor</b>		
Model		KSN140D21UFZ
Type		ROTARY
Brand		GMCC
Capacity	W	4385
Input	W	1140
Rated current(RLA)	A	7.50
Refrigerant oil/oil charge	ml	VG74 440
<b>Refrigerant piping</b>		
Liquid side/ Gas side	mm(inch)	9.52mm(3/8in)/15.9mm(5/8in)
Max. refrigerant pipe length	m	30
	inch	1181
Max. difference in level	m	20
	inch	787
Connection wiring		16#x4
Operation temperature	°C	17~30
	°F	63~86
Indoor temperature	°C	16~32
	°F	63~90
Outdoor temperature	°C	0~50
	°F	34~122
Application area (Cooling Standar	m <sup>2</sup>	29~43
	ft <sup>2</sup>	312.0/462.7

## OUTDOOR UNIT DATA

<b>Outdoor fan motor</b>		
Model		ZKFN-34-10-1L-1
Input	W	/
Capacitor	uF	/
Speed	r/min	900/700/550
Outdoor air flow	m3/h	2500
	CFM	1471
Outdoor noise level	dB(A)	59
Outdoor unit Dimension(W*D*H)	mm	805x330x554
	inch	31.7x13.0x21.8
Outdoor unit Packing (W*D*H)	mm	940x410x605
	inch	37.01x16.14x23.82
Outdoor unit Net/Gross weight	kg	27.7/32.9
	lbs	61.1/72.53

Indoor unit dimension

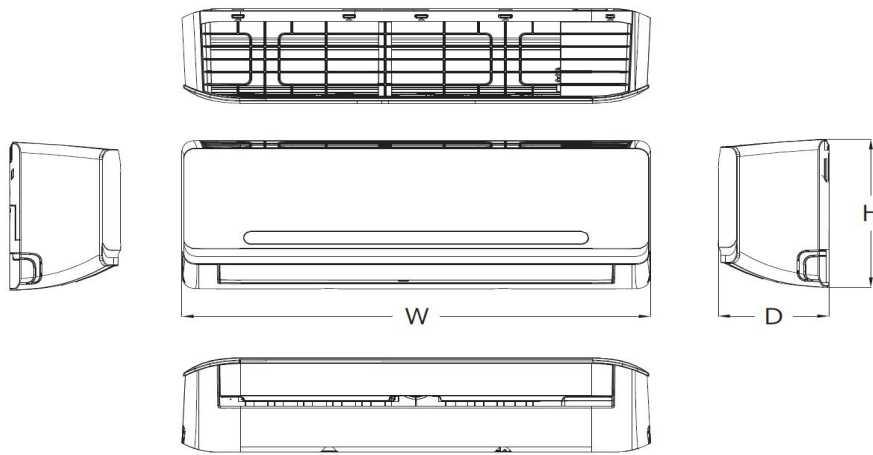

(The figure is for reference only)

Dimension(inch)	W	D	H
CAC12CA(I)	31.6	7.9	11.6
CAC12CD(I)	31.6	7.9	11.6
CAC18CD(I)	38.2	9.0	12.6
CAC24CD(I)	42.6	9.2	13.3

Outdoor unit dimension

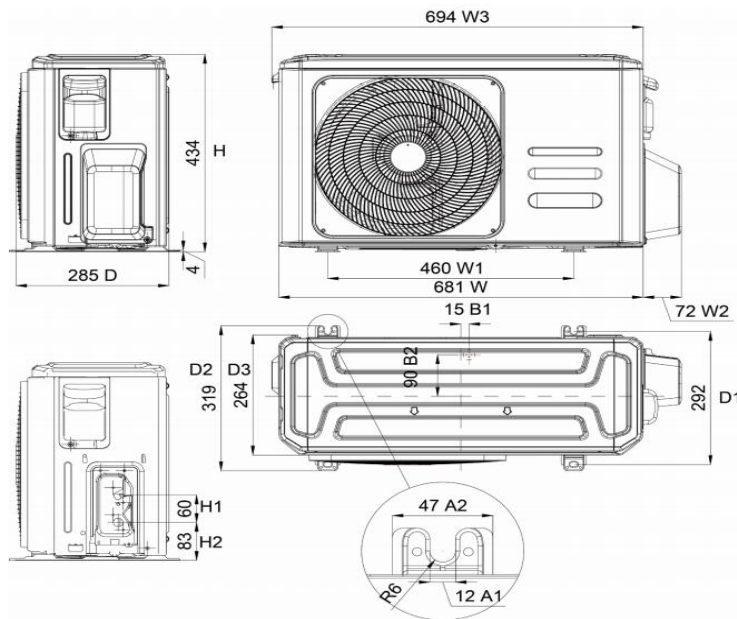

(The figure is for reference only)

Dimension(inch)	W	D	H
CAC12CA(O)	28.3	10.6	19.5
CAC12CD(O)	28.3	10.6	19.5
CAC18CD(O)	30.1	11.9	21.9
CAC24CD(O)	31.7	13.0	21.8