

SUBMITTAL DATA SHEET

ComfortStar®

CFU12CA

Location: _____
 Engineer: _____
 Submitted to: _____
 Submitted by: _____
 Reference: _____

Approval: _____
 Date: _____
 Construction: _____
 Unit #: _____
 Drawing #: _____

Set Model
 Indoor unit model CFU12CA(I)
 Outdoor unit model CFU12CA(O)

Certified AHRI 



SYSTEM PERFORMANCE DATA

Power supply	V-Ph-Hz	115V_1Ph, 60HZ
Cooling Capacity	Btu/h	12000
Input	W	1320
Current	A	14.0
EER	W/W	2.66
EER2	BUT/W	9.1
AHRI-SEER2	BUT/W	18.0
Rated Power Input	W	2000
Rated Current	A	17.0

INDOOR UNIT DATA

Indoor fan motor		
Model		YKFG-15-4-28-1
Input	W	46
Capacitor	uF	3
Speed(Hi/Mi/Lo)	r/min	1150/950/750
Indoor air flow (Hi/Mi/Lo)	m3/h	560/420/310
	CFM	329/247/182
Indoor noise level (Hi/Mi/Lo)	dB(A)	40.0/36/27.5
Indoor unit Dimension(W*D*H)	mm	805x194x285
	inch	31.7x7.6x11.2
Indoor unit Packing (W*D*H)	mm	870x285x360
	inch	34.25x11.22x14.17
Indoor unit Net/Gross weight	kg	7.6/10.3
	lbs	16.8/22.71

REFRIGERANT PIPE DATA

Compressor		
Model		KSK103D32UEZ31
Type		ROTARY
Brand		GMCC
Capacity	W	2020/3245 ±3%
Input	W	332/850 ±3%
Rated current(RLA)	A	2.42/5.70 ±3%
Refrigerant oil/oil charge	ml	ESTER OIL VG74 280 ±10
Refrigerant piping		
Liquid side/ Gas side	mm(inch)	6.35mm(1/4in)/9.52mm(3/8in)
Max. refrigerant pipe length	m	25
	inch	984
Max. difference in level	m	10
	inch	394
Connection wiring		16#x4
Operation temperature	°C	17~30
	°F	63~86
Indoor temperature	°C	17~32
	°F	63~90
Outdoor temperature	°C	0~50
	°F	34~122
Application area (Cooling Standar	m ²	16~23
	ft ²	173~247

OUTDOOR UNIT DATA

Outdoor fan motor		
Model		ZKFN-25-10-5L
Input	W	/
Capacitor	uF	/
Speed	r/min	800/600
Outdoor air flow	m3/h	1800
	CFM	1059
Outdoor noise level	dB(A)	53.5
Outdoor unit Dimension(W*D*H)	mm	720x270x495
	inch	28.3x10.6x19.5
Outdoor unit Packing (W*D*H)	mm	842x357x550
	inch	33.15x14.06x21.65
Outdoor unit Net/Gross weight	kg	21.6/24.2
	lbs	47.7/53.35

Indoor unit dimension

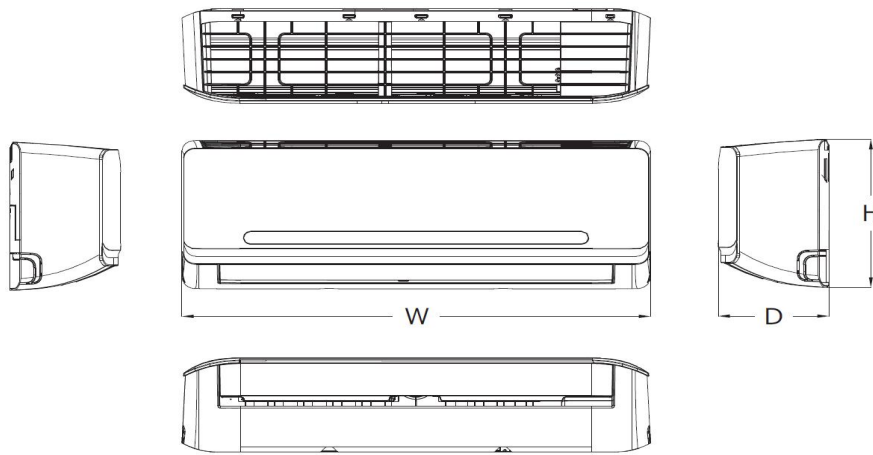

(The figure is for reference only)

Dimension(Inch)	W	D	H
CFU12CA(I)	31.7	7.6	11.2
CFU12CD(I)	31.7	7.6	11.2
CFU18CD(I)	37.7	8.4	11.9
CFU24CD(I)	40.9	8.7	12.9

Outdoor unit dimension

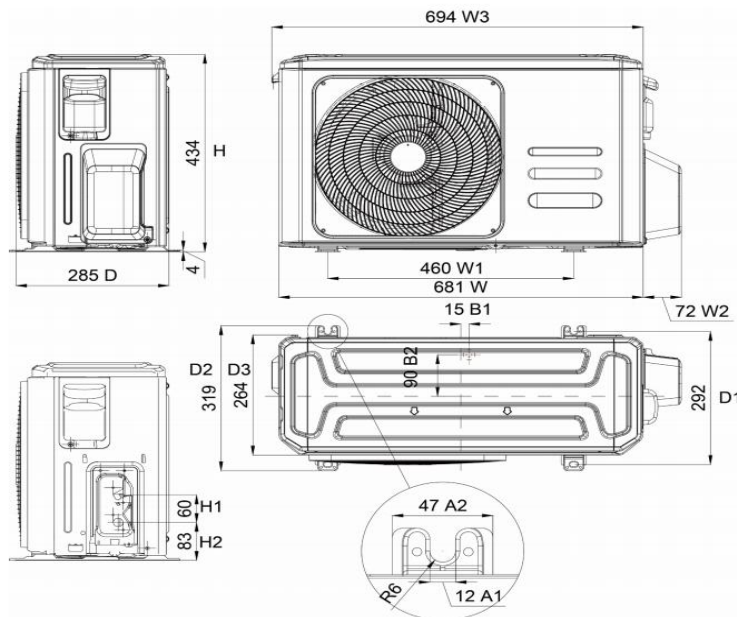

(The figure is for reference only)

Dimension(Inch)	W	D	H
CFU12CA(O)	28.3	10.6	19.5
CFU12CD(O)	28.3	10.6	19.5
CFU18CD(O)	30.1	11.9	21.9
CFU24CD(O)	31.7	13.0	21.8