

SUBMITTAL DATA SHEET

ComfortStar®

CFU18CD

Location: _____ Engineer: _____ Submitted to: _____ Submitted by: _____ Reference: _____	Approval: _____ Date: _____ Construction: _____ Unit #: _____ Drawing #: _____
--	--

Set Model	
Indoor unit model	CFU18CD(I)
Outdoor unit model	CFU18CD(O)
Certified	AHRI 



SYSTEM PERFORMANCE DATA			
Power supply	V-Ph-Hz	220_230V_1Ph,	60HZ
Cooling Capacity	Btu/h		17000
Input	W		1650
Current	A		7.2
EER	W/W		3.02
EER2	BUT/W		10.3
AHRI-SEER2	BUT/W		18.0
Rated Power Input	W		3000
Rated Current	A		13.5

INDOOR UNIT DATA			
Indoor fan motor			
Model			ZKFP-30-8-297L
Input	W		/
Capacitor	uF		/
Speed(Hi/Mi/Lo)	r/min		1200/1000/800
Indoor air flow (Hi/Mi/Lo)	m3/h		800/650/480
	CFM		470/382/282
Indoor noise level (Hi/Mi/Lo)	dB(A)		43/37/30
Indoor unit Dimension(W*D*H)	mm		957x213x302
	inch		37.7x8.4x11.9
Indoor unit Packing (W*D*H)	mm		1035x305x380
	inch		40.7x12.01x14.96
Indoor unit Net/Gross weight	kg		9.5/12.2
	lbs		21.0/26.9

REFRIGERANT PIPE DATA			
Compressor			
Model			KSK103D32UEZ31
Type			ROTARY
Brand			GMCC
Capacity	W		2020/3245 ±3%
Input	W		332/850 ±3%
Rated current(RLA)	A		2.42/5.70 ±3%
Refrigerant oil/oil charge	ml		ESTER OIL VG74 280 ±10
Refrigerant piping			
Liquid side/ Gas side	mm(inch)		6.35mm(1/4in)/12.7mm(1/2in)
Max. refrigerant pipe length	m		30
	inch		1181
Max. difference in level	m		20
	inch		787
Connection wiring			16#x4
Operation temperature	°C		17~30
	°F		63~86
Indoor temperature	°C		17~32
	°F		63~90
Outdoor temperature	°C		0~50
	°F		34~122
Application area (Cooling Standar	m ²		23~33
	ft ²		247~355

OUTDOOR UNIT DATA			
Outdoor fan motor			
Model			ZKFN-25-10-5L
Input	W		/
Capacitor	uF		/
Speed	r/min		810/450
Outdoor air flow	m3/h		2100
	CFM		1235
Outdoor noise level	dB(A)		53
Outdoor unit Dimension(W*D*H)	mm		765x303x555
	inch		30.1x11.9x21.9
Outdoor unit Packing (W*D*H)	mm		885x375x605
	inch		34.84x14.76x23.82
Outdoor unit Net/Gross weight	kg		22.7/26.7
	lbs		50.1/58.86

Indoor unit dimension

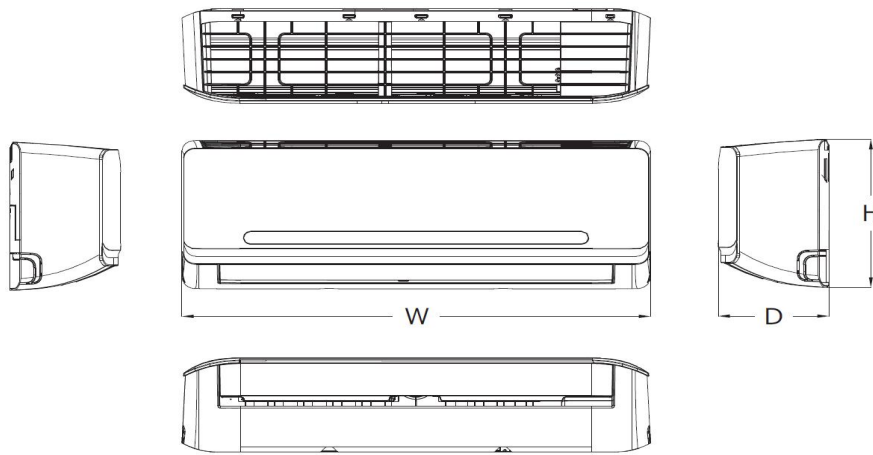

(The figure is for reference only)

Dimension(Inch)	W	D	H
CFU12CA(I)	31.7	7.6	11.2
CFU12CD(I)	31.7	7.6	11.2
CFU18CD(I)	37.7	8.4	11.9
CFU24CD(I)	40.9	8.7	12.9

Outdoor unit dimension

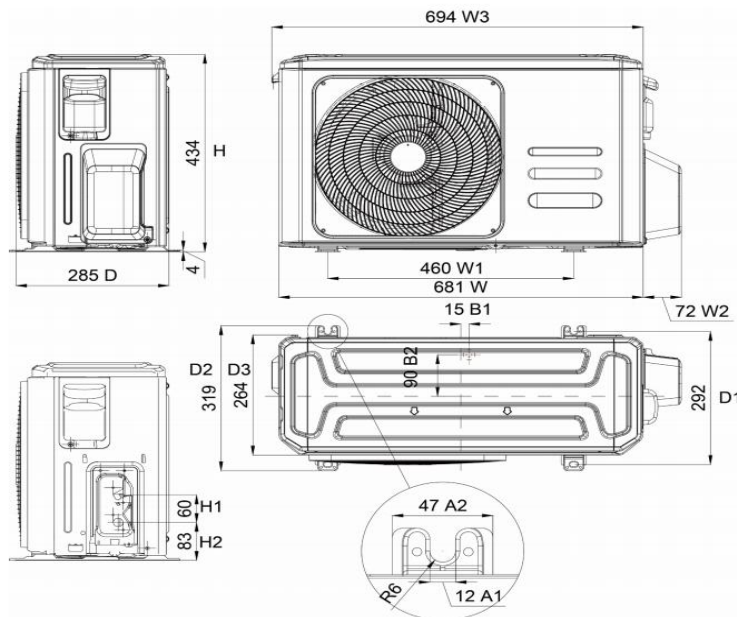

(The figure is for reference only)

Dimension(Inch)	W	D	H
CFU12CA(O)	28.3	10.6	19.5
CFU12CD(O)	28.3	10.6	19.5
CFU18CD(O)	30.1	11.9	21.9
CFU24CD(O)	31.7	13.0	21.8