

SUBMITTAL DATA SHEET



CSA12CD-S

Location: _____
 Engineer: _____
 Submitted to: _____
 Submitted by: _____
 Reference: _____

Approval: _____
 Date: _____
 Construction: _____
 Unit #: _____
 Drawing #: _____

Set Model

Indoor unit model CSA12CD-S(I)
 Outdoor unit model CSA12CD-S(O)



SYSTEM PERFORMANCE DATA

Power supply	V-Ph-Hz	220-240V/1Ph / 60Hz
Cooling Capacity	Btu/h	12000
Input	W	1200.00
Current	A	5.30
EER	W/W	2.9
SEER	Btu/W	13.0
Max. input consumption	W	1650.0
Max. current	A	7.90

INDOOR UNIT DATA

Indoor fan motor		
Model		YYK19-4
Output	W	19.00
Capacitor	uF	1.5
Speed(Hi/Mi/Lo)	r/min	1200/1200/1100/1000
Indoor air flow (Hi/Mi/Lo)	m3/h	600/550/480
	CFM	353/324/282
Indoor noise level (Hi/Mi/Lo)	dB(A)	39/37/34
Indoor unit Dimension(W*D*H)	mm	800X292X190
	inch	31.5x11.5x7.5
Indoor unit Packing (W*D*H)	mm	865x335x240
	inch	34.1x13.2x9.4
Indoor unit Net weight	kg	7.4
	lbs	16.33
Indoor unit Gross weight	kg	8.55
	lbs	18.87

REFRIGERANT PIPE DATA

Compressor		
Model		QXA-B122rT130U
Type		ROTARY
Brand		GREE
Capacity	W	3715.0
Input	W	1285.0
Rated current(RLA)	A	5.9
Locked rotor Amp(LRA)	A	28.1
Refrigerant oil/oil charge	ml	280.00
Refrigerant piping		
Liquid side	inch	1/4"
Gas side	inch	3/8"
Max. refrigerant pipe length	m	10
	inch	393.70
Max. difference in level	m	5
	inch	196.85
Operation temperature	°C	16~43
	°F	61~109
Ambient temperature range	°C	16~48
	°F	61~118
Application area	m ²	13~27
	ft ²	140~291

OUTDOOR UNIT DATA

Outdoor fan motor		
Model		YDK25-6
Output	W	25
Capacitor	uF	2.5
Speed	r/min	860±30
Outdoor air flow	m3/h	/
	CFM	/
Outdoor noise level	dB(A)	49
Outdoor unit Dimension(W*D*H)	mm	700×276×550
	inch	27.6x10.9x21.7
Outdoor unit Packing (W*D*H)	mm	810x355x595
	inch	31.9x14.0x23.4
Outdoor unit Net weight	kg	25.5
	lbs	56.27
Outdoor unit Gross weight	kg	28
	lbs	61.78

Indoor unit dimension

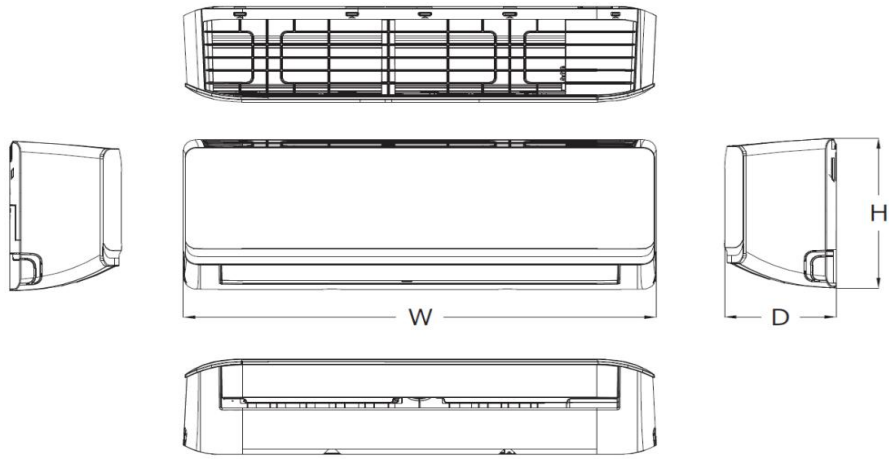

(The figure is for reference only)

Dimension(inch)	W	H	D
CSA12CD-S(I)	31.5	11.5	7.5
CSA18CD-S(I)	38.2	12.2	9.1
CSA24CD-S(I)	38.2	12.2	9.1

Outdoor unit dimension

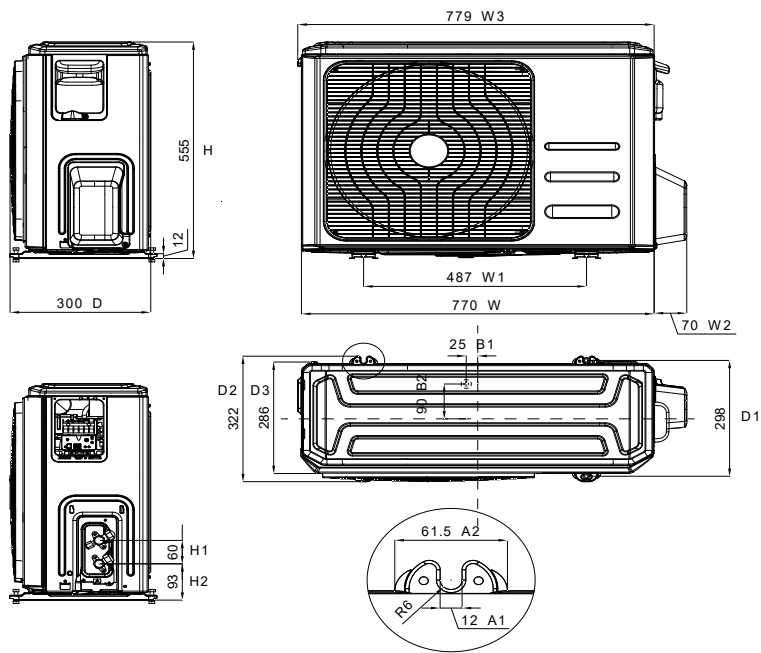

(The figure is for reference only)

Dimension(inch)	W	H	D
CSA12CD-S(O)	27.6	10.9	21.7
CSA18CD-S(O)	30.0	21.7	10.1
CSA24CD-S(O)	35.5	25.6	12.4