



Submittal

Split System Cooling

CWM4-36-15

Location: _____
Engineer: _____
Submitted to: _____
Submitted by: _____
Reference: _____

Approval: _____
Date: _____
Construction: _____
Unit # : _____
Drawing # : _____



Note:" *Graphics in this document are for representation only. Actual model may differ in appearance.*"

Unit dimension

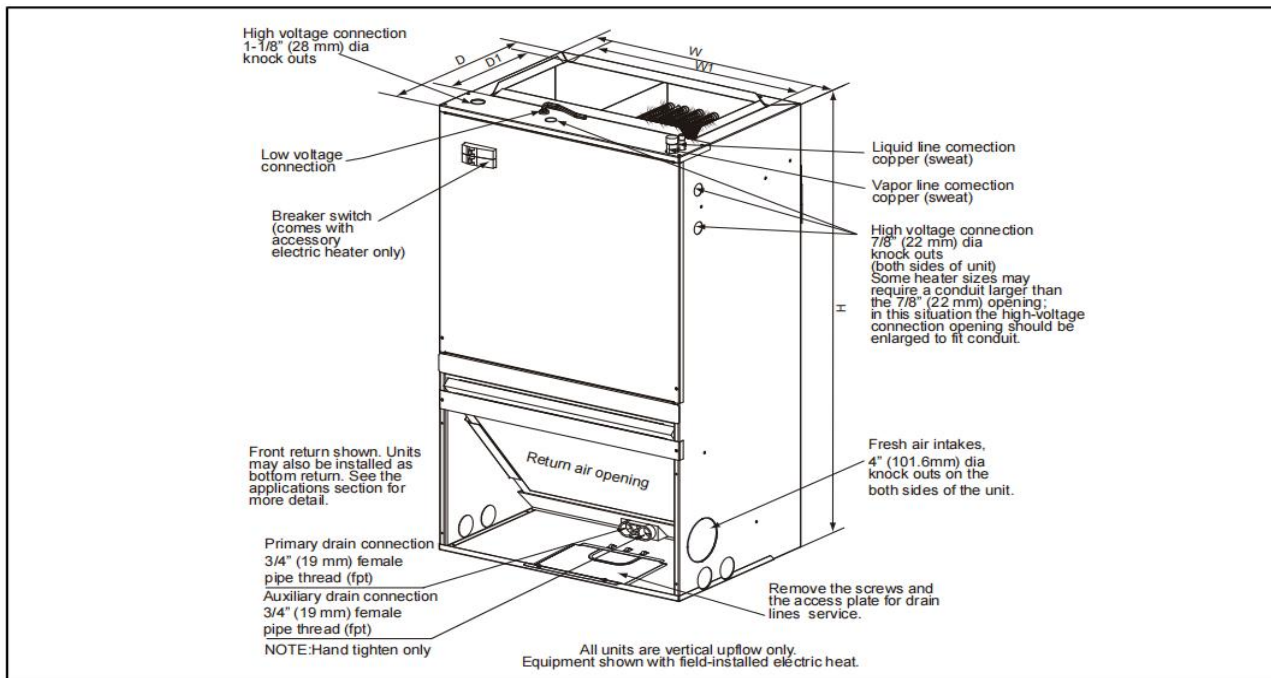

Model	Dimensions [IN.]					Unit Weight/Shipping Weight Lbs.
	Unit Height "H" IN.	Unit Width "W" IN.	Unit Width "W1" IN.	Unit Depth "D" IN.	Unit Depth "D1" IN.	
18K/24K	36-1/2	20-1/2	17-2/5	15	9-1/2	92/101
30K/36K	39-1/2	21-9/10	18-4/5	17-1/2	9-1/2	97/119

Specification

Model		CWM4-36-15	
Indoor fan motor	Type		ECM
	Power supply		AC220-240V/50 60Hz
	Model		DZJ-373F-12
	Output	W	373
	rate current	A	3.8
	Speed	rpm	1050
Static pressure		Pa	75
Indoor air flow		CFM	1080
Indoor noise level		dB(A)	53.5
Throttling type			Piston
Indoor coil	Evaporator type		Copper tube&Aluminum foil
	Number of row		5 rows 14u
	Tube pitch(a)xrow pitch(b)	in	0.83x0.53
	Fin spacing	in	1/17
	Evaporator dimension	in	18-1/2"x23-3/20"x2-3/5"
Indoor dimension	Unit dimension (W*D*H)	in	21-9/10"x17-1/2"x39-1/2"
		mm	559x447x1004
		in	24-1/2"x21-4/5"x42-1/10"
		mm	625x555x1070
	Net / Gross weight	kg	47.5/53
	lbs	106/124.4	

Outdoor Unit	Indoor Unit	Cooling Capacity	EER2	SEER2
BAR4-36-15	CWM4-36-15	34000	11.7	14.3

Heater Kit Accessories

Model	Description	18K	24K	30K	36K
CHE4-05B	5 kW heating kit, single-pole circuit breaker	•	•	•	•
CHE4-08B	7.5 kW heating kit, single-pole circuit breaker	•	•	•	•
CHE4-10B	10 kW heating kit, single/double pole circuit breaker	•	•	•	•

MCA/MOP data of electric heat kit

Heat kit model	AHU model	(kW) electric heat	MIN. Circuit Ampacity		MAX. Fuse or Breaker (HACR) Ampacity		Fan speed				
			230 VAC	208 VAC	230 VAC	208 VAC	1	2	3	4	5
CHE4-05B	18K	5	22.68	19.66	25	25	•	•	•	•	•
CHE4-08B		7.5	34.04	29.50	40	35	×	×	•	•	•
CHE4-10B		10	45.37	39.32	55	45	×	×	•	•	•
CHE4-05B	24K	5	22.68	19.66	25	25	•	•	•	•	•
CHE4-08B		7.5	34.04	29.50	40	35	×	×	•	•	•
CHE4-10B		10	45.37	39.32	55	45	×	×	•	•	•
CHE4-05B	30K	5	22.68	19.66	25	25	•	•	•	•	•
CHE4-08B		7.5	34.04	29.50	40	35	×	•	•	•	•
CHE4-10B		10	45.37	39.32	55	45	×	×	•	•	•
CHE4-05B	36K	5	22.68	19.66	25	25	•	•	•	•	•
CHE4-08B		7.5	34.04	29.50	40	35	×	•	•	•	•
CHE4-10B		10	45.37	39.32	55	45	×	×	•	•	•

ComfortStar®

12201 N W 107th Avenue
Miami, FL 33178
1.866.524.9898 Toll Free
305.500.9898 Office
305.500.9896 Fax
<http://www.comfortstarusa.com>



The AHRI mark indicates Comfortstar participating in the AHRI Certification program. Visit ahridirectory.org for verification of individual certified products. Comfortstar reserves the right to change design and specs without notice. Comfortstar has a policy of update the data continuously. We are committed to using environmentally conscious print practices.

CWM4-36-15 23th Feb 2023
Supersedes CWM4-36-15 (Feb.2023)

© 2023 ComfortStar