

Technical Manual

ComfortStar®

CWM4 & BAR4 Series

SEER2 Wall Mounted Air Handler & Condensing Units

R410A 208/230V 1Ph 60Hz

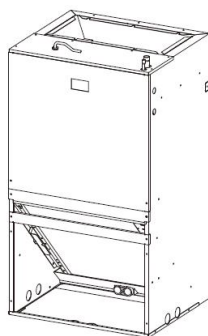

IMPORTANT NOTE:

Read this manual carefully before operating your new air conditioning unit. Make sure to save this manual for future reference.

Please check the applicable models, technical data,

F-GAS(if any) and manufacturer information from the "Owner's Manual " in the packaging of the outdoor unit.

Content

- Part 1. General Information 1**
 - 1. Model Names of Indoor/Outdoor Units 1
 - 2. External Appearance 3
 - 3. Features 4
- Part 2. Indoor Unit5**
 - 1.Features 6
 - 2.Dimension9
 - 3.Service Space 10
 - 4.Wiring Diagrams 11
 - 5. Electric Characteristics 12
 - 6. Electrical Wiring 12
 - 7. Field Wiring 12
- Part 3 Outdoor Unit13**
 - 1. Dimension 14
 - 2. Service Space 15
 - 3. Wiring Diagrams16
 - 4. Electric Characteristics 16
 - 5. Operation Limits 17
 - 6. Sound Levels 17
 - 7. Refrigerate diagram18
- Part 4 Installation19**
 - 1. Precaution on Installation 20
 - 2. Emptying22
 - 3. Additional Refrigerant Charge 22
 - 4. Insulation Work23
- Part 5 Unit maintenance 25**
 - 1. Fault indicator of indoor unit.....26
 - 2. Fault indicator of outdoor unit 26
 - 3. Troubleshooting of Fault Codes 27

Part 1. General Information

1. Model Names of Indoor/Outdoor Units	2
2. External Appearance	3
3. Features	4

1. Model Names of Indoor/Outdoor Units

1.1 Indoor Units

Model name	Dimension(W×H×D)(inch)	Power supply
CWM4-18-15	20-1/2"×15"×36-1/2"	208/230V-1Ph-60Hz
CWM4-24-15	20-1/2"×15"×36-1/2"	208/230V-1Ph-60Hz
CWM4-30-15	21-9/10"x17-1/2"x39-1/2"	208/230V-1Ph-60Hz
CWM4-36-15	21-9/10"x17-1/2"x39-1/2"	208/230V-1Ph-60Hz

1.2 Outdoor Units

Model name	Dimension (W×H×D) (inch)	Power supply
BAR4-18-15	21-4/5×25×21-4/5	208/230V-1Ph-60Hz
BAR4-24-15	21-4/5×25×21-4/5	208/230V-1Ph-60Hz
BAR4-30-15	29-1/7×25×29-1/7	208/230V-1Ph-60Hz
BAR4-36-15	29-1/7×25×29-1/7	208/230V-1Ph-60Hz

2. External Appearance

2.1 Indoor unit



2.2 Outdoor unit



Note: Standard outdoor unit is using plastic grill. Metal grill can be customized.



Louvered steel grille

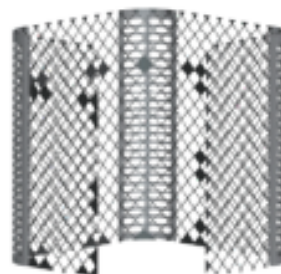

Plastic grille

3. Features

3.1 Operation features

- Long Piping & Cost Effective
- Low noise operation, as low as 48dB(A)
- 24V control, Two-stage fan speed control, anti-cooling fan delay, heating fan delay and transformer included.

3.2 Performance features

- AHRI Certified & ETL listed.
- R410A environment friendly refrigerant.
- Wide operation temperature range: Cooling: 58⁰F-115⁰F; Heating(general mode): 19⁰F-75⁰F; Heating(high vertical mode): 32⁰F-75⁰F
- Continuous Cooling Transformation Inner-grooved oxygen free copper pipe with high thermometric conductivity.

3.3 Reliability features

- Painted galvanized steel cabinet.
- Well-known brand scroll compressor, reliable quality.
- Condenser coils constructed with copper tubing and enhanced aluminum fins.
- 5-speed DC motors, provide selections of air flow to meet desired applications.
- Intelligent defrost programs, unit will choose different defrost program according to real condition.

Part 2. Indoor Unit

1.Features	6
2.Dimension	9
3.Service Space	10
4.Wiring Diagrams	11
5.Electric Characteristics	12
6.The Specification of Wiring	12
7.Field Wiring	12

1. Features

(1) “A” shape coils, constructed with Inner-grooved oxygen free copper pipe and enhanced aluminum fins.

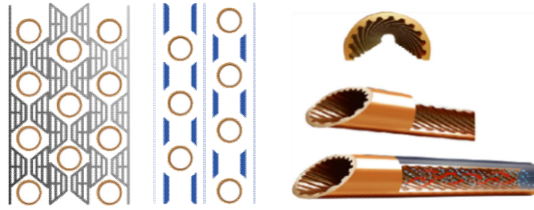

(2) ECM motors, the air handler has multiple fan modes to choose from, which can flexibly respond to various environments.

(3) Powerful fan speed, and the motor is covered with insulation material, which can ensure that the motor runs in a safe state.



(4) Use Piston as throttle device



(5) Optional air filter (Optional)

Detachable air filter for cleaning or renewal, designed to provide fresh and healthy air indoors.

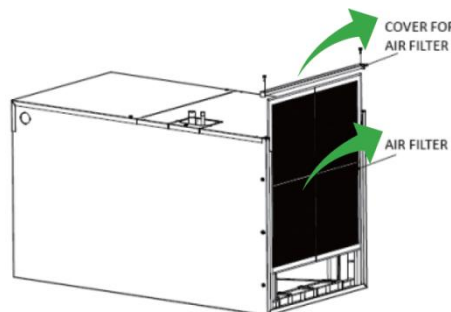

Model	Filter size inches[mm]
18K/24K	16X20[406X508]
30K/36K	20X20[508X508]

Remark: The thickness of the filter should within 1”(25mm).

(6) Electric Heater with Different Power (Optional)

SEER2 Wall Mounted CWM4 Electric Heater		
Specification	Bom	Applicable model
5 kw	8024325A0001	18/24/30/36K
7.5 kw	8024325A0002	
10 kw	8024325A0003	24/30/36K



(7) The wall mounted CWM4 comes standard with two different options for mounting

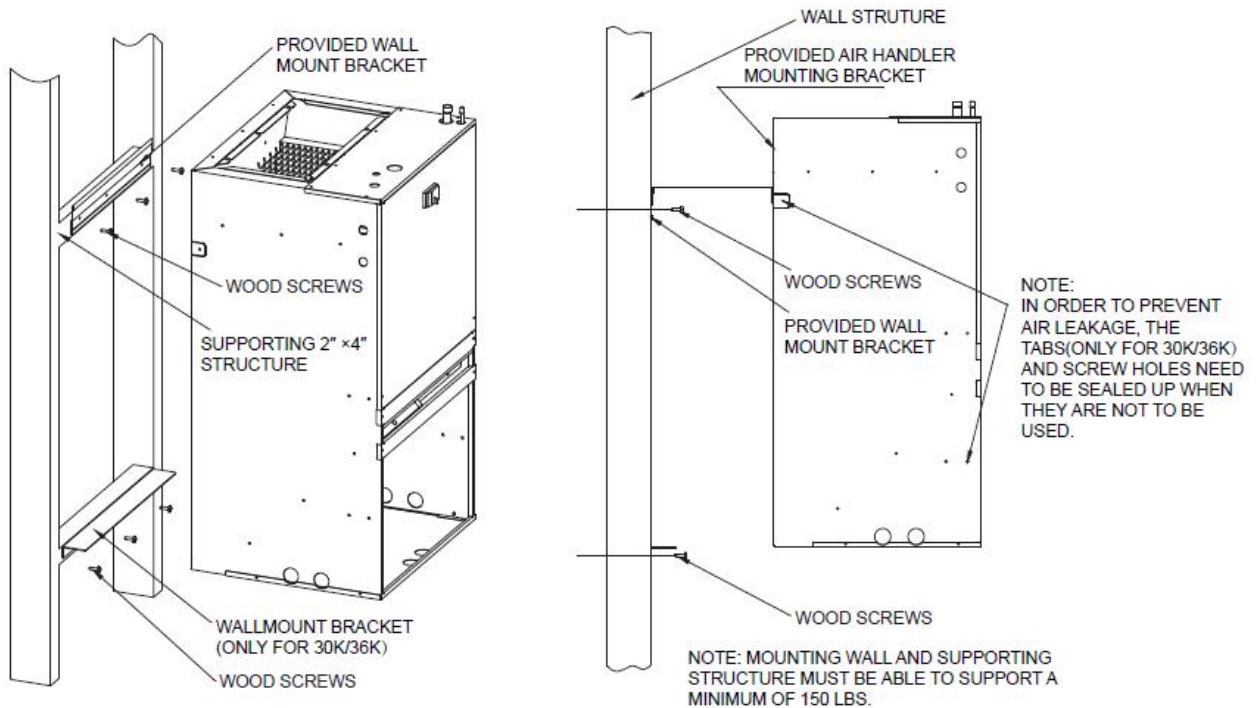

WALL MOUNT

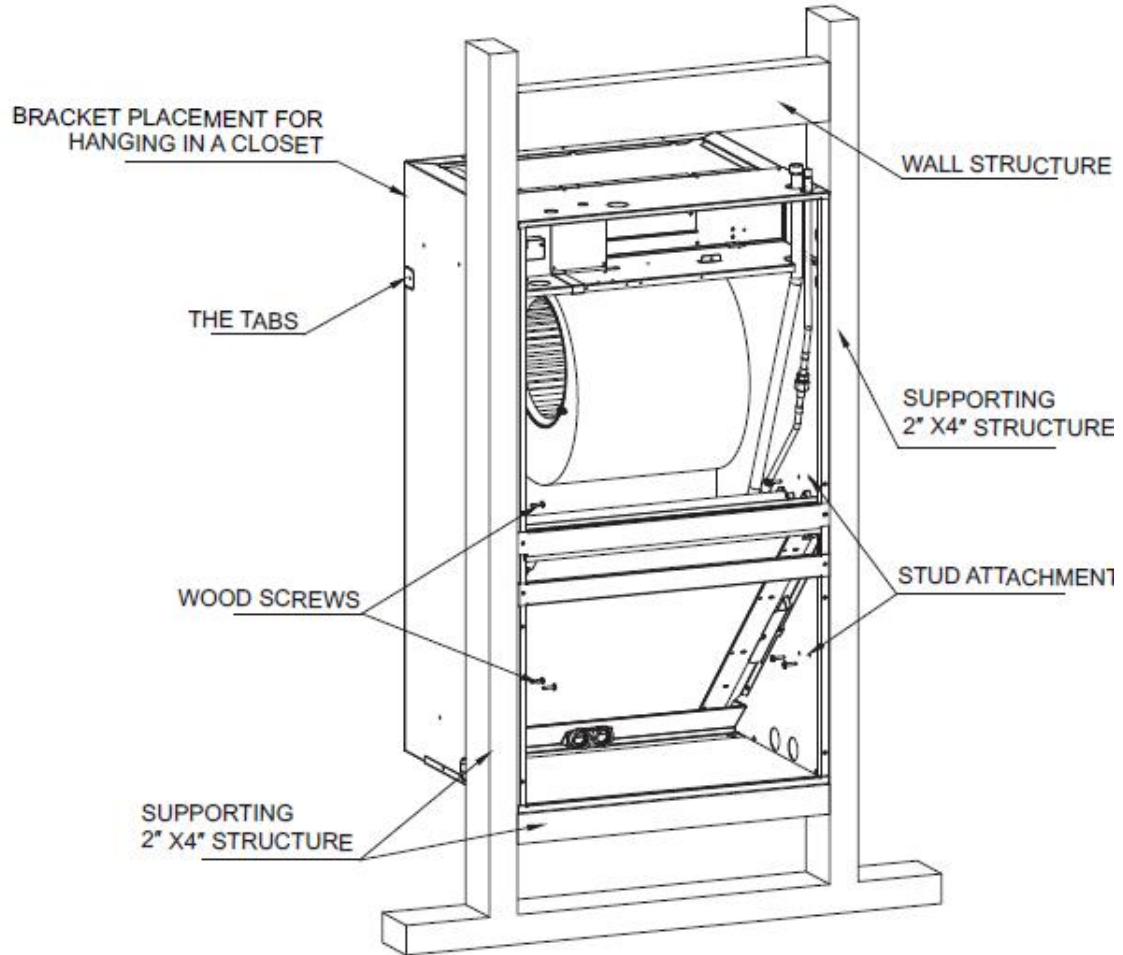

FRAME MOUNT

Remark: The detailed installation instruction, refer to part 3 of installation manual.

2. Dimension

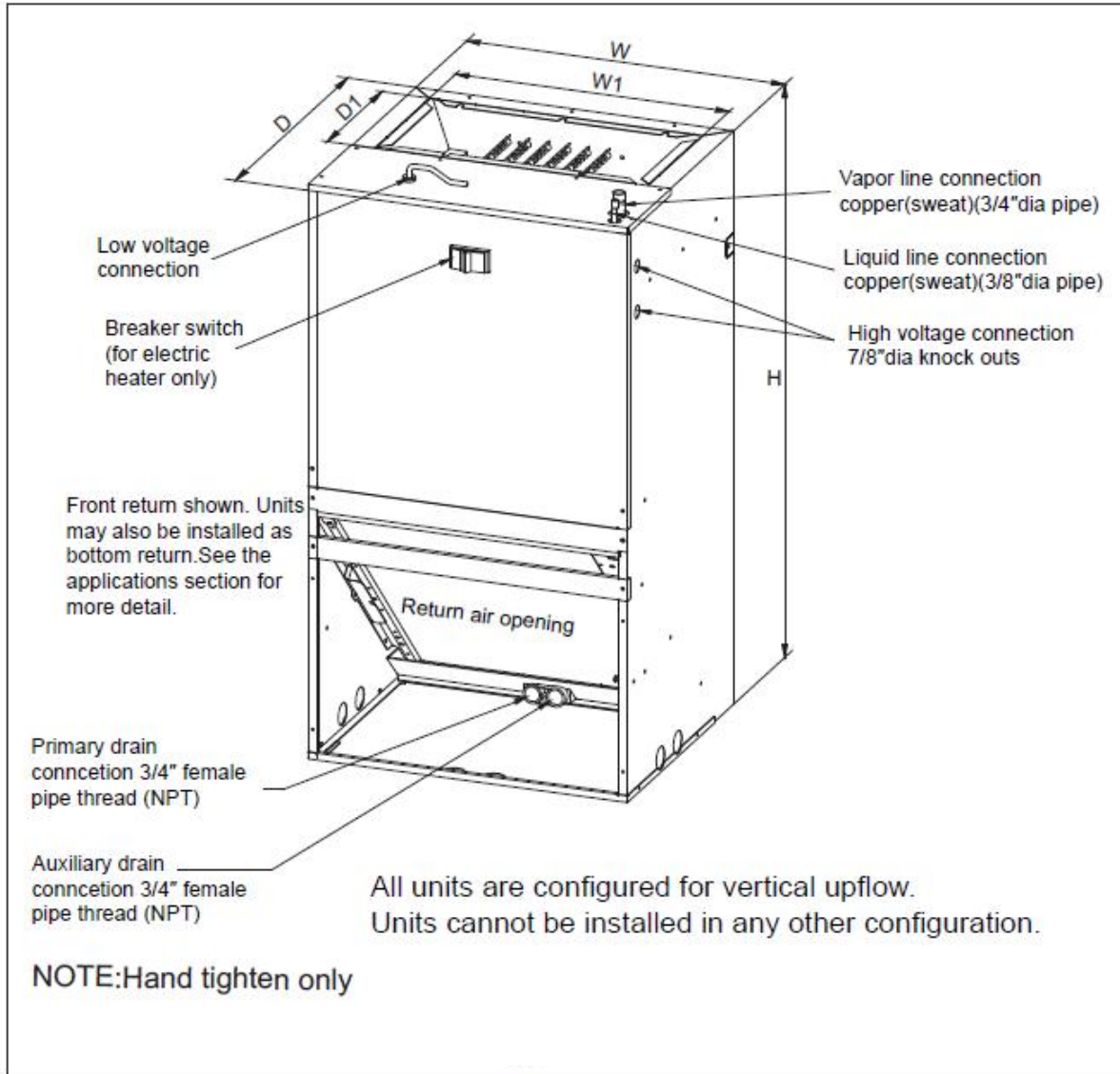

Model Size	Dimensions inch (mm)					Unit Weight /Shipping Weight (LBS.(kg))
	Unit Height "H" inch (mm)	Unit Width "W" inch (mm)	Unit Width "W1" inch (mm)	Unit Length "D" inch (mm)	Unit Length "D1" inch (mm)	
18	36-1/2 (928)	20-2/3 (526)	17-1/2 (446)	15 (381)	9-1/2 (242)	88/101 (37)/(41.5)
24	36-1/2 (928)	20-2/3 (526)	17-1/2 (446)	15 (381)	9-1/2 (242)	88/101 (37)/(41.5)
30	39-1/2 (1004)	22 (559)	18-4/5 (478)	19 (483)	9-1/2 (242)	106/124.4 (47.5)/(53)
36	39-1/2 (1004)	22 (559)	18-4/5 (478)	19 (483)	9-1/2 (242)	106/124.4 (47.5)/(53)

3. Service Space

Make sure enough clearance is reserved for effective air flow and convenient for installation and maintenance.

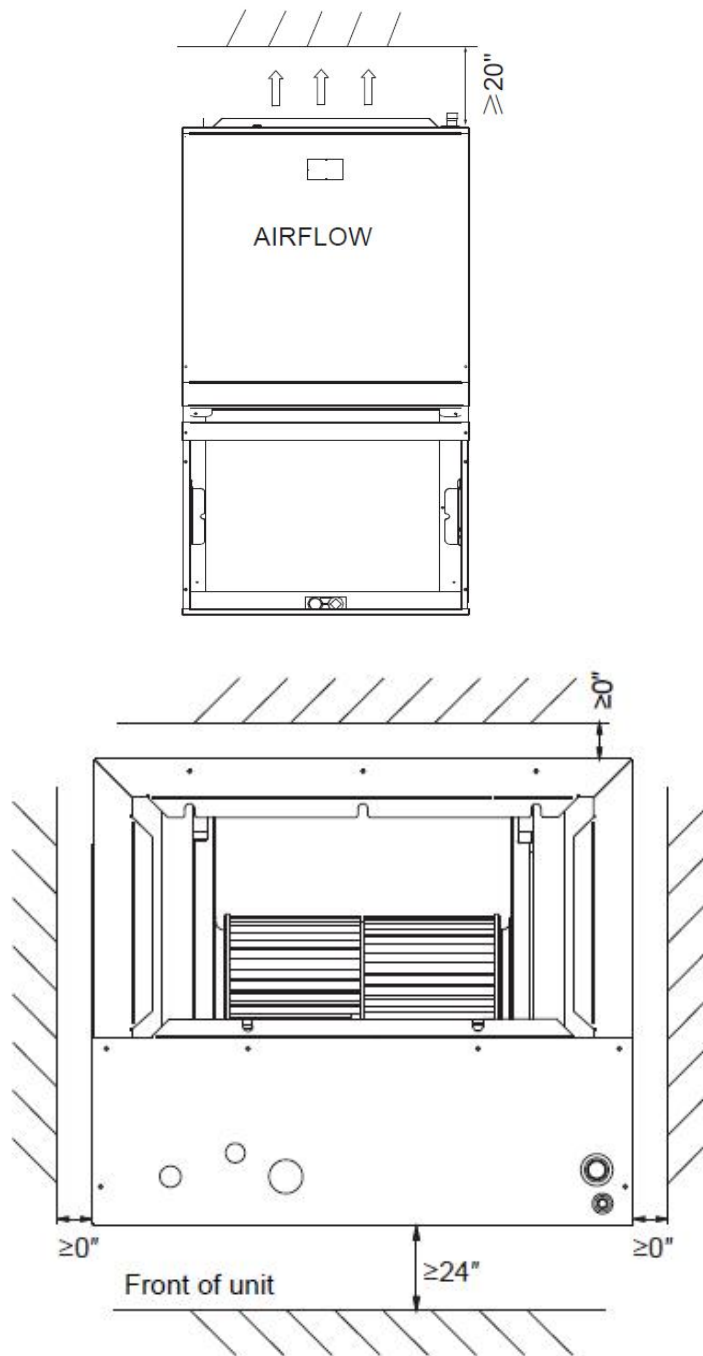

4. Wiring Diagrams

18K/24K/30K/36K

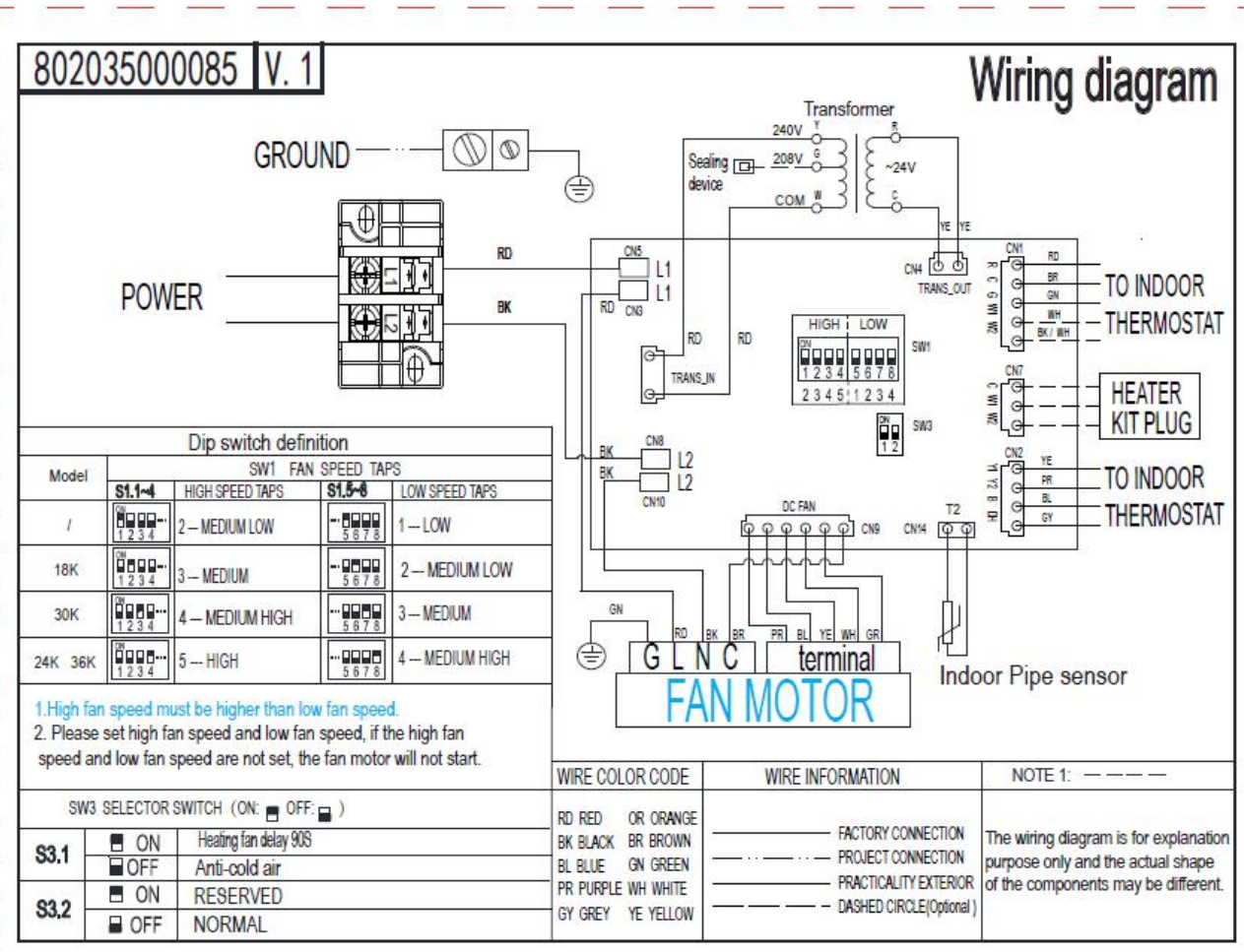

5. Electric Characteristics

Model	Voltage	Hertz	HP	Wind speed	Circuit AMPS	Maximum circuit protector
18K	208/230	60	1/3	5	0.8	5 (A)
24K	208/230	60	1/3	5	1.1	5 (A)
30K	208/230	60	1/2	5	1.3	5 (A)
36K	208/230	60	1/2	5	2.0	5 (A)

6. Electrical Wiring

Note:

The diameters of wires or lines should not be less than the corresponding ones listed in the table below; Besides, if the power wires is quite long from the unit, please choose the windings with larger cross-section area to guarantee the normal power supply.

Type (Btu/ hour)		18K	24K	30K	36K	
Power	Stage	Single				
	Voltage/frequency	208/230VAC, 60 Hz				
Wire gauge	Indoor unit power cord	Line quantity	3	3	3	3
		Wire diameter (AWG)	16	16	16	16
	Outdoor unit power cord	Line quantity	3	3	3	3
		Wire diameter (AWG)	14	14	12	12

7. Field Wiring

1. To avoid the electrical shock, please connect the air conditioner with the ground lug. The main power plug in the unit has been joined with the ground wiring, please don't change it freely.
2. The power socket is used as the air conditioner specially.
3. Don't pull the power wiring hard.
4. When connecting the air conditioner with the ground, observe the local codes.
5. If necessary, use the power fuse or the circuit, breaker or the corresponding scale ampere.

Remark: Please refer to the installation manual for more different kinds of wiring information.

Part 3 Outdoor Unit

1. Dimensions	14
2. Service Space	15
3. Wiring Diagrams	16
4. Electric Characteristics	16
5. Operation Limits	17
6. Sound Levels	17
7. Refrigerate diagram	18

1. Dimension

When installing the outdoor unit on the roof, make sure that the roof can support the weight of the outdoor unit. It is recommended to choose appropriate isolation to prevent sound or vibration from being transmitted to the building structure.

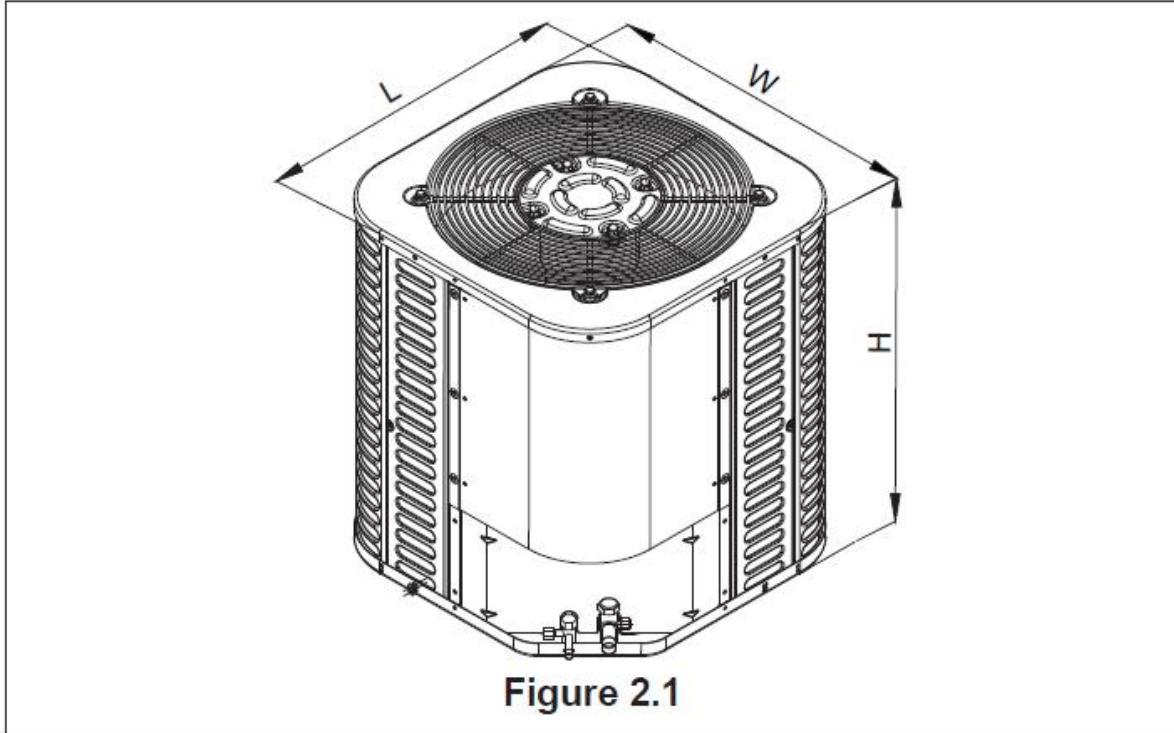

Model	H×W×L(inch)
18K/24K	25×21-4/5×21-4/5
30K/36K	25×29-1/7×29-1/7

2. Service Space

1. Make sure that the discharge area at least 60 inches above the top of the unit is unrestricted.
2. The clearance from one side of the access panel to the wall should be at least 24 inches.
3. Except for access panel, please leave a min 12" from shrubbery around other side panels.

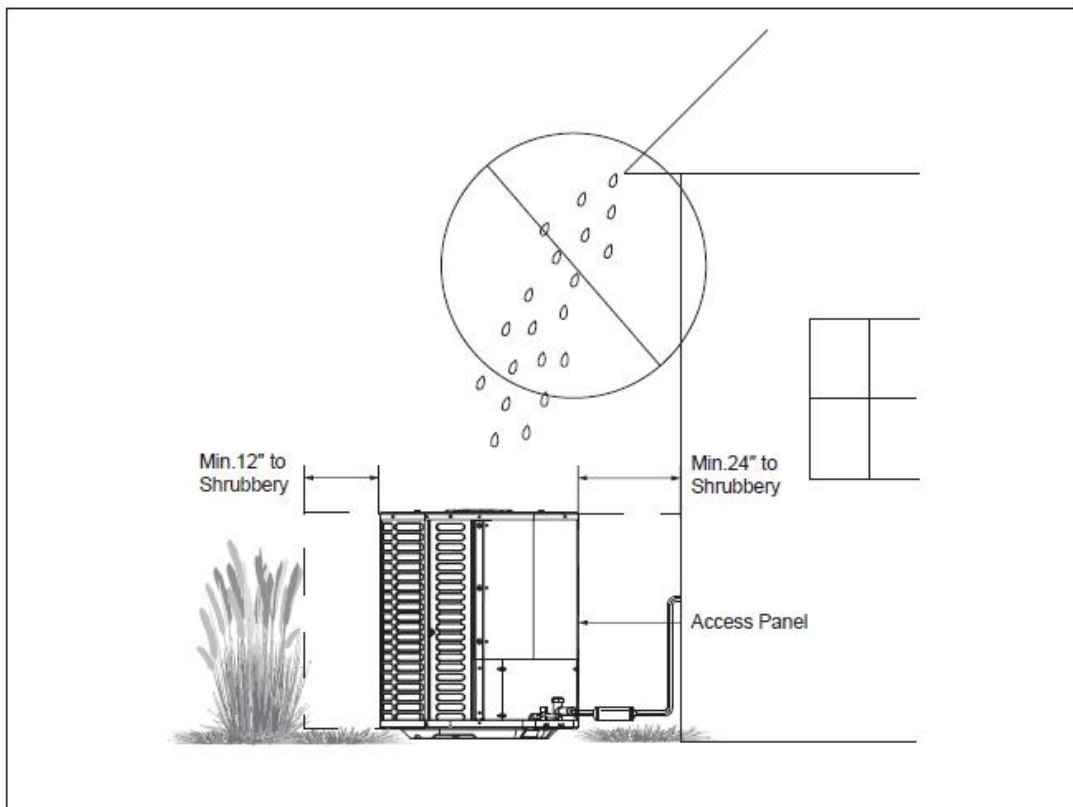
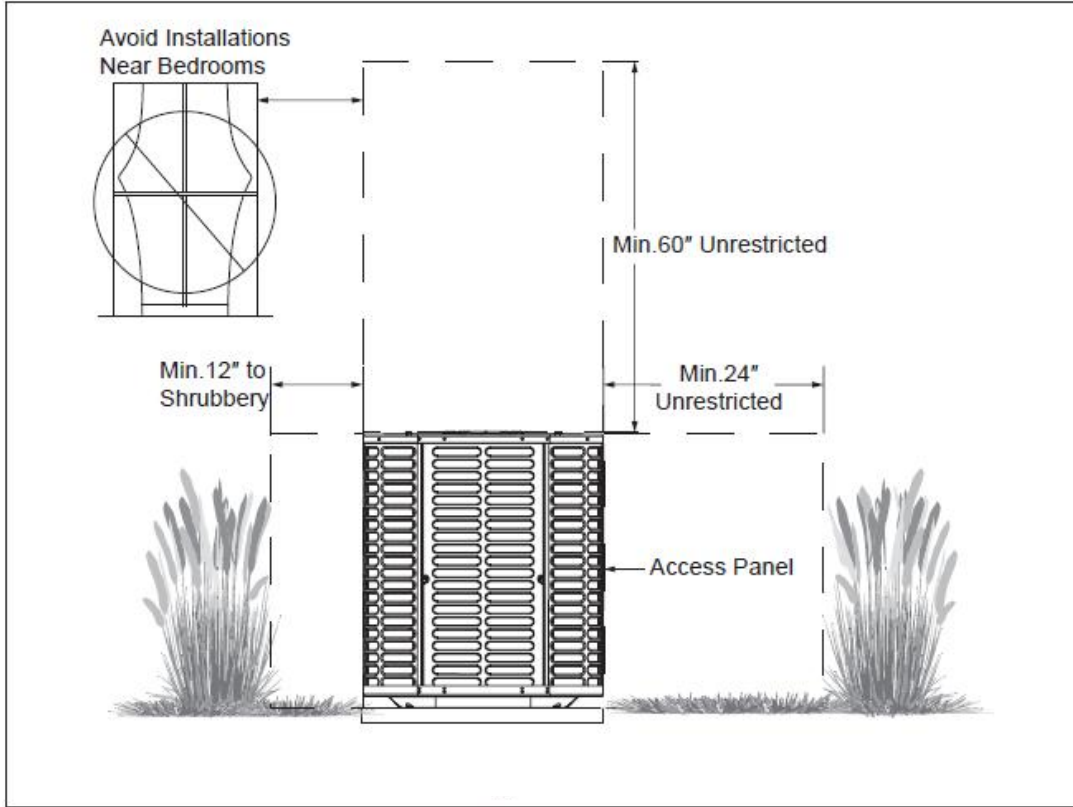

3. Wiring Diagram

Cooling only

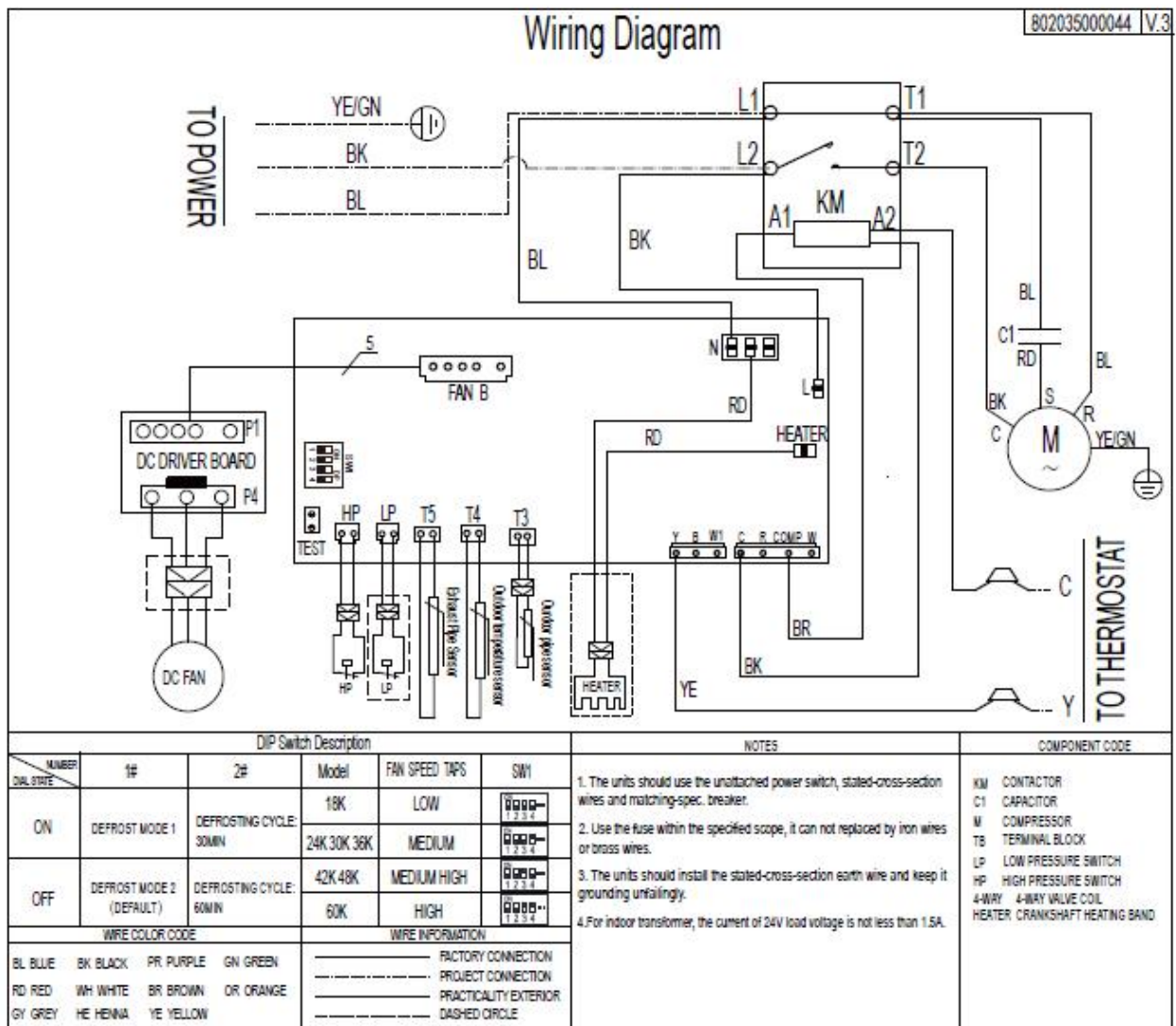

4. Electric Characteristics

Model	Outdoor Unit (Scroll)					
	Hz	Voltage	Min.	Max.	MIN. Circuit Ampacity	Maxi Fuse
BAR4-18-15	60	208/230V	187V	253V	13	20
BAR4-24-15					13	20
BAR4-30-15					15	25
BAR4-36-15					20	30

5. Operation Limits

Operation mode	Outdoor temperature (°F)
Cooling mode	58~115
General heat pump mode	19~75
High vertical heat pump mode	32~75

6. Sound Levels

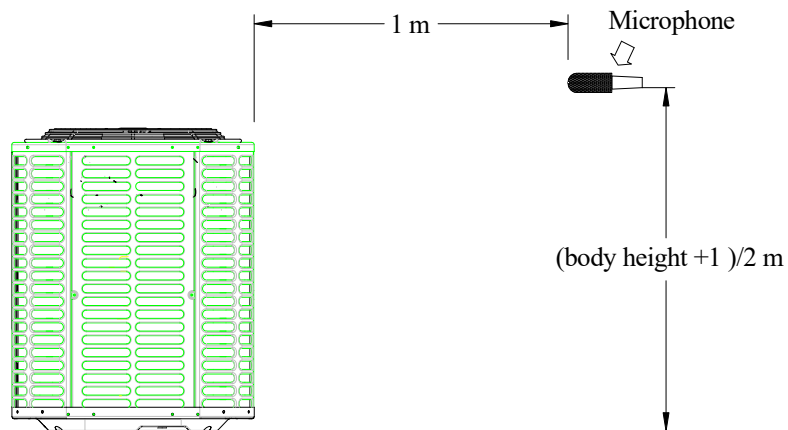

Model	Noise level dB(A)
18K	60
24K	60
30K	61.5
36K	62

Note: Sound level is measured at a point 1 m in front of the unit, at a height of (Unit body height + 1)/2 m.

7. Refrigerate diagram

Applicable for cooling only type

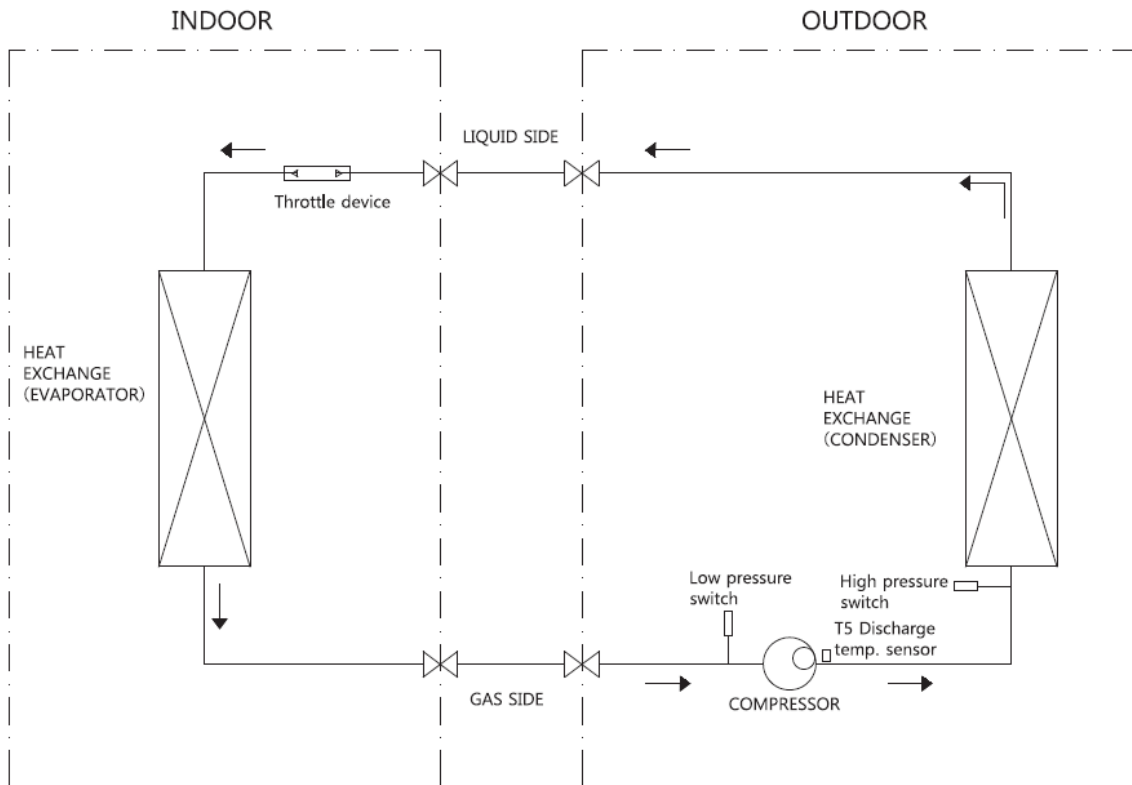

Part 4 Installation

1 .Precaution on Installation	20
2. Emptying	22
3. Additional Refrigerant Charge	22
4. Insulation Work	23

1. Precaution on Installation

1.1 Measure the necessary length of the connecting pipe, and make it by the following way

a. Connect the indoor unit at first, then the outdoor unit. Bend the tubing in proper way.

CAUTIONS:

- Daub the surfaces of the flare pipe and the joint nuts with frozen oil, and wrench it for 3~4 rounds;
 - Fasten the flare nuts;
 - Be sure to use two wrenches simultaneously when you connect or disconnect the pipes.
- b. The stop value of the outdoor unit should be closed absolutely (as original state). Every time you connect it, first loosen the nuts at the part of stop value, then connect the flare pipe immediately (in 5 minutes). If the nuts have been loosened for a long time, dusts and other impurities may enter the pipe system and may cause malfunction later. So please expel the air out of the pipe with refrigerant before connection.
- c. Emptying the air after connecting the refrigerant pipe with the indoor unit and the outdoor unit. Then fasten the nuts at the repair-points.

1.2 Locate the Pipe

- a. Drill a hole in the wall (suitable just for the size of the wall conduit), then set on the fittings such as the wall conduit and its cover.
- b. Bind the connecting pipe and the cables together tightly with binding tapes. Do not let air in, which will cause water leakage by condensation.
- c. Pass the bound connecting pipe through the wall conduit from outside. Be careful of the pipe allocation to do no damage to the tubing.
- d. Insulate the pipeline from all piping systems.
- e. Try to reduce the number of 90° laps.

1.3 Connect the pipes

Connecting Dimensions of Refrigerant Lines and Service Valves are shown as below table:

Model	Suction line	Liquid line	Suction line connection	Liquid line connection
			The dimensions are in inches.	
18K/24K/30K/36K	3/4	3/8	3/4	3/8

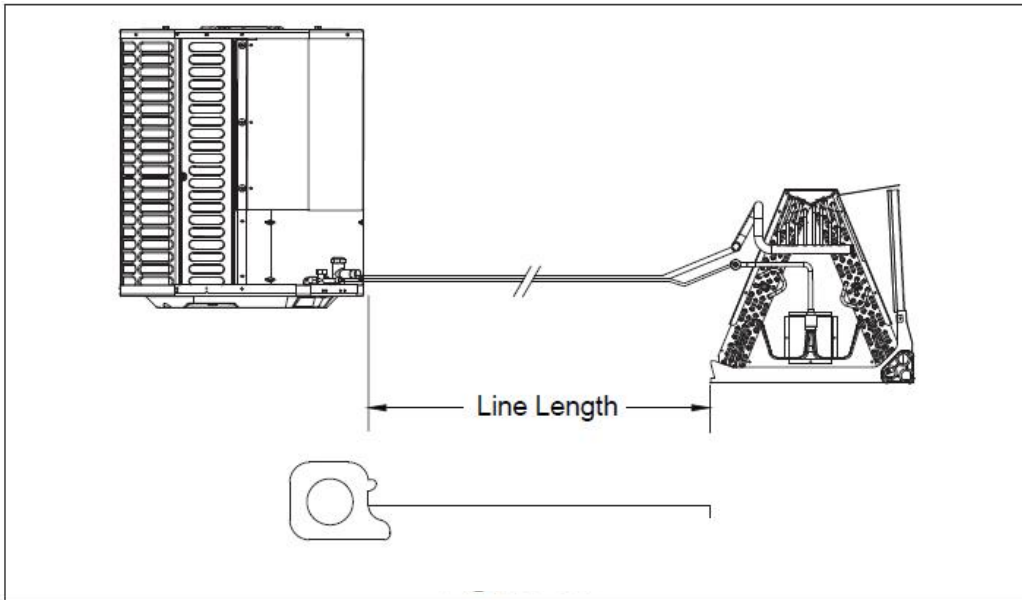

1.4 Refrigerant Pipeline Leakage Inspection

- a. Use dry nitrogen to pressurize the refrigerant line and evaporator coil to 150 PSIG.

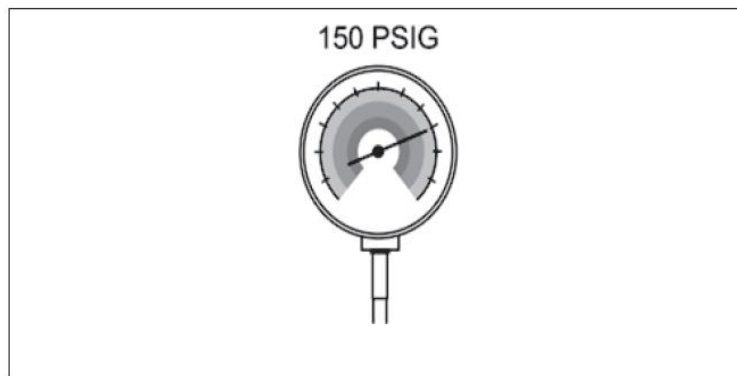

- b. Use soapy water or foam at each soldering position to check for leaks.

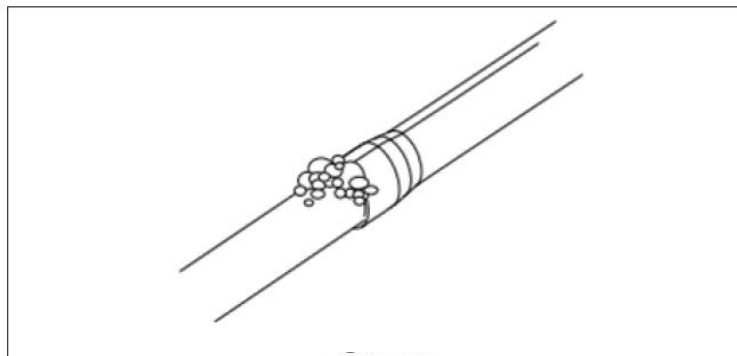

1.5 Then, open the stem of stop valves of the outdoor unit to make the refrigerant pipe connecting the indoor unit with the outdoor unit in fluent flow.

1.6 Cover the joint of the connecting pipe to the indoor unit with the soundproof / insulating sheath (fittings), and bind it well with the tapes to prevent leakage.

2. Emptying

CAUTIONS:

Do not open the service valve until the leakage inspection and emptying of refrigerant lines and indoor coils are completed.

1. Evacuate until the micrometer reading is not higher than 350 micrometers, and then close the valve of

the vacuum pump.

2. Observe micrometer gauge. If the micrometer meter does not rise above 500 micrometers within one (1) minute, the evacuation is completed.

After the evacuation, turn off the vacuum pump and micrometer, and close the valve on the manifold

instrument cluster.

3. Additional Refrigerant Charge

CAUTIONS:

- Refrigerant cannot be charged until field wiring has been completed.
- Refrigerant may only be charged after performing the leak test and the vacuum pumping.
- When charging a system, care shall be taken that its maximum permissible charge is never exceeded, in view of the danger of liquid hammer.
- Charging with an unsuitable substance may cause explosions and accidents, so always ensure that the appropriate refrigerant is charged.
- Refrigerant containers shall be opened slowly.
- Always use protective gloves and protect your eyes when charging refrigerant.

The outdoor unit is charged with refrigerant from factory. Calculate the additional refrigerant according to the diameter and the length of the liquid side pipe of the outdoor unit/indoor unit. There are two methods for additional refrigerant charging:

1. During the initial installation, or when the refrigerant quantity of the updated system is charged, the weighing method is used. All models have a charge factor of 0.6 oz / ft for refrigerant pipe length.

Model	Refrigerant pipeline length	Charge factor
All models	≤25ft	Factory charge data on nameplate
	>25ft	0.6 oz / ft

2. When the outdoor ambient temperature is higher than 55°F, recommending use sub-cooling (cooling mode) charging method. For outdoor ambient temperature below 55°F, use the weighing charging method.

Remark: Please go to the 14th part of the installation manual for more charging details.

4. Insulation Work

4.1 Insulation material and thickness

1. Insulation material

Insulation material should adopt the material which is able to endure the pipe's temperature: no less than 70°C in the high-pressure side, no less than 120°C in the low-pressure side (For the cooling type machine, no requirements at the low-pressure side.)

- ◆ Example: Heat pump type----Heat-resistant Polyethylene foam (withstand above 120°C)
Cooling only type----Polyethylene foam (withstand above 100°C)

2. Thickness choice for insulation material

Insulation material thickness is as follows:

	Pipe diameter (mm)	Adiabatic material thickness
Refrigerant pipe	Φ6.4—Φ25.4	10mm
	Φ28.6—Φ38.1	15mm
Drainage pipe	Inner diameterΦ20—Φ32	6mm

4.2 Refrigerant pipe insulation

1. Work Procedure

- ① Before laying the pipes, the non-jointing parts and non-connection parts should be heat insulated.
- ② When the gas proof test is eligible, the jointing area, expanding area and the flange area should be heat insulated.

2. Insulation for non-jointing parts and non-connection parts

wrong	right	
Gas pipe and liquid pipe should not be put together to insulate	Insulate the gas pipe (cooling only)	Insulate the gas pipe and liquid pipe

For construction convenience, before laying pipes, use insulation material to insulate the pipes to be dealt with, at the same time, at two ends of the pipe, remain some length not to be insulated, in order to be welded and check the leakage after laying the pipes.

3. Insulate for the jointing area, expanding area and the flange area

- ① Insulate for the jointing area, expanding area and the flange area should be done after checking leakage of the pipes
- ② Make sure there's no clearance in the joining part of the accessorial insulation material and local preparative insulation material.

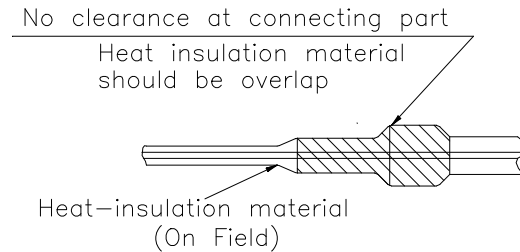

4.3 Drainage pipe insulation

The connection part should be insulated, or else water will be condensing at the non-insulation part.

4.4 Note

- 1. The jointing area, expanding area and the flange area should be heat insulated after passing the pressure test.
- 2. The gas and liquid pipe should be heat insulated individually, the connecting part should be heat insulated individually.
- 3. Use the attached heat-insulation material to insulate the pipe connections (pipes' tie-in, expand nut) of the indoor unit.

Part 5 Unit maintenance

1. Fault indicator of indoor unit	26
2. Fault indicator of outdoor unit	26
3. Troubleshooting of Fault Codes	27

1. Fault indicator of indoor unit

The meaning of the fault indicator:

Content		Description
Normal display	Unit is standby	Green light flash 1 time every 3 seconds
	Unit is running normally	Green light ON
Indoor unit error: Green light flashing	T2 temp. sensor error	Green light flash 2 time for every 8s
	Anti-cold air	Green light flash 3 times for every 8s

2. Fault indicator of outdoor unit

The meaning of the fault indicator:

Content		Description
Normal display: green light flashes, yellow light OFF	Green light flash slow	Unit standby
	Green light ON	Unit is running
Outdoor unit error: Green light slow flash, Yellow light flashing	T3 temp. sensor error	Yellow light flash 1 time for every 8s
	T4 temp. sensor error	Yellow light flash 2 times for every 8s
	T5 temp. sensor error	Yellow light flash 3 times for every 8s
	Low pressure protection	Yellow light flash 4 times for every 8s
	High pressure protection	Yellow light flash 5 times for every 8s
	T3 high temperature protection	Yellow light flash 6 times for every 8s
	T5 high temperature protection	Yellow light flash 7 times for every 8s
	Fan motor feedback error	Yellow light flash 8 times for every 8s (Only for DC fan motor)
Outdoor unit error & locked: Green light ON, Yellow light flash	Low pressure protection occurs 6 times within 60 mins	Yellow light flash 4 times for every 8s
	Low pressure protection occurs 6 times within 60 mins	Yellow light flash 5 times for every 8s
	T3 high temp. protection occurs 6 times within 60 mins	Yellow light flash 6 times for every 8s
	T5 high temp. protection occurs 3 times within 20 mins	Yellow light flash 7 times for every 8s

3. Troubleshooting of Fault Codes

3.1 T3 Condenser Temperature sensor error

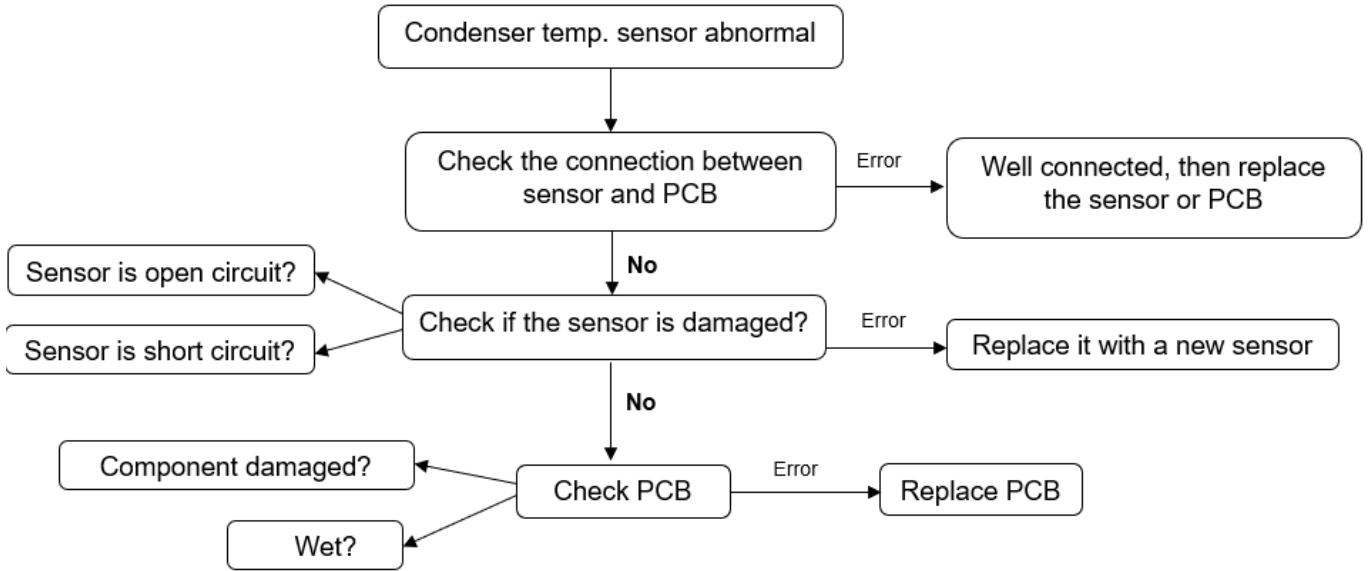

3.2 T4 Outdoor Ambient Temperature sensor error

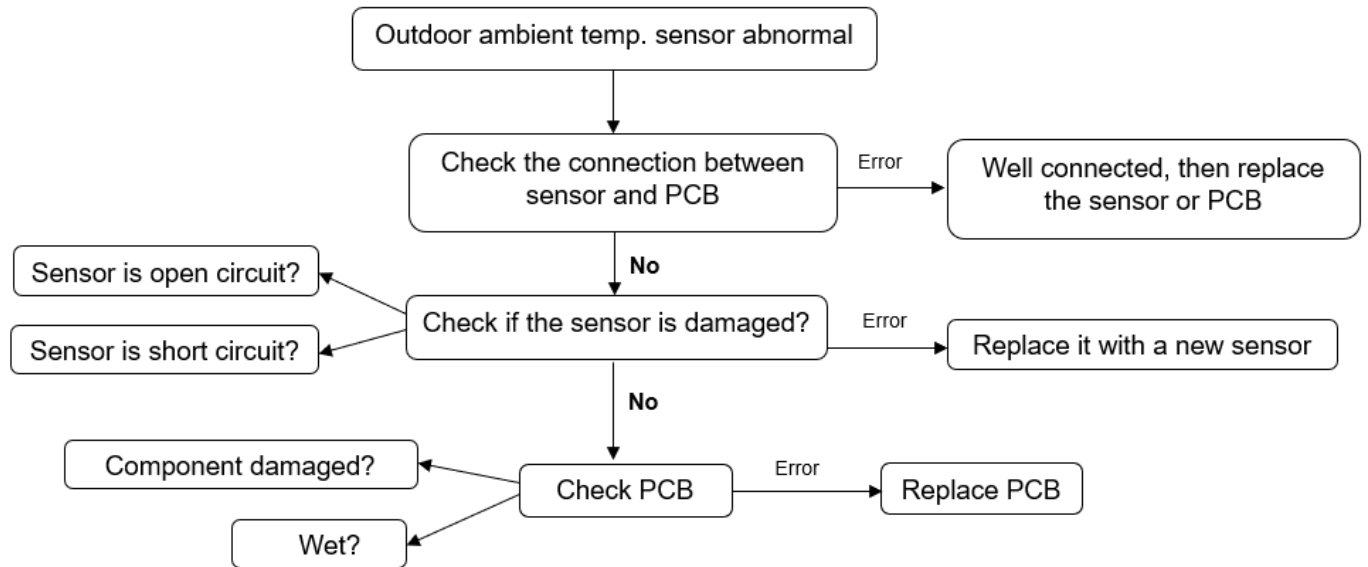

3.3 T5 Discharge Temperature sensor error

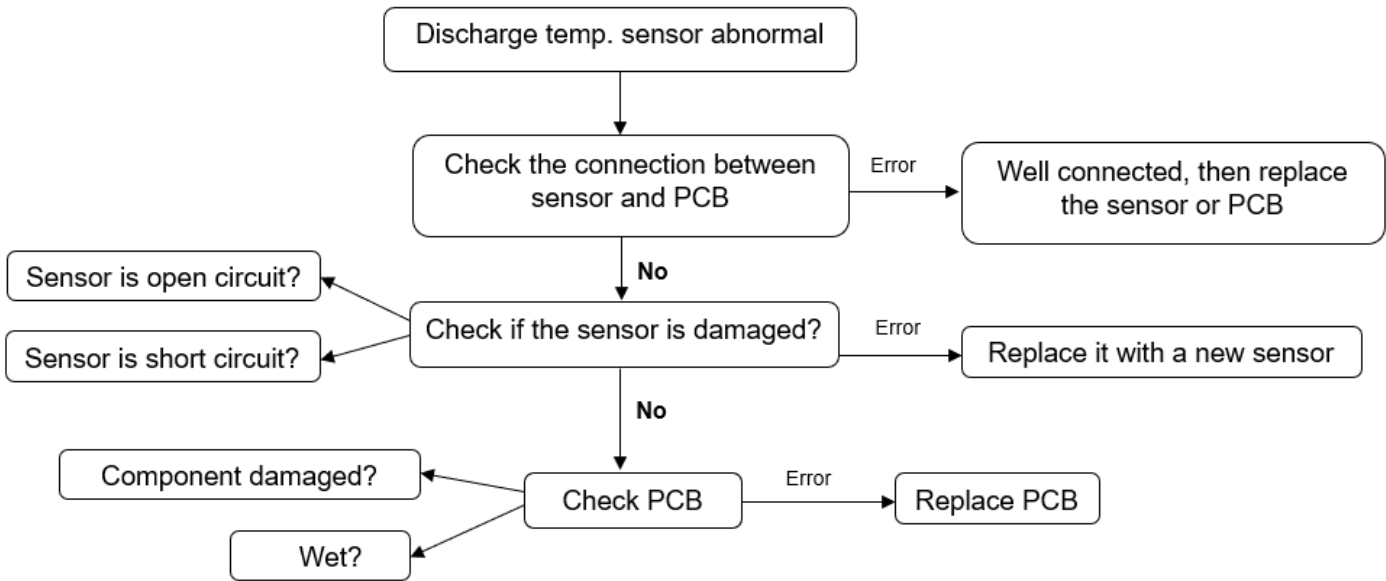

3.4 Low Pressure alarm

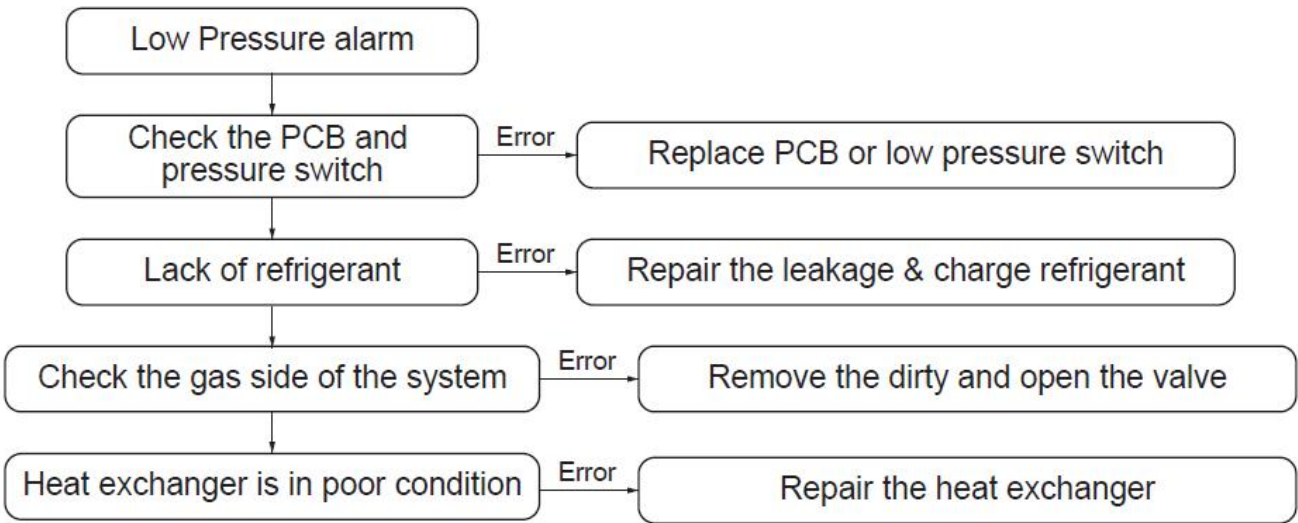

3.5 High Pressure alarm

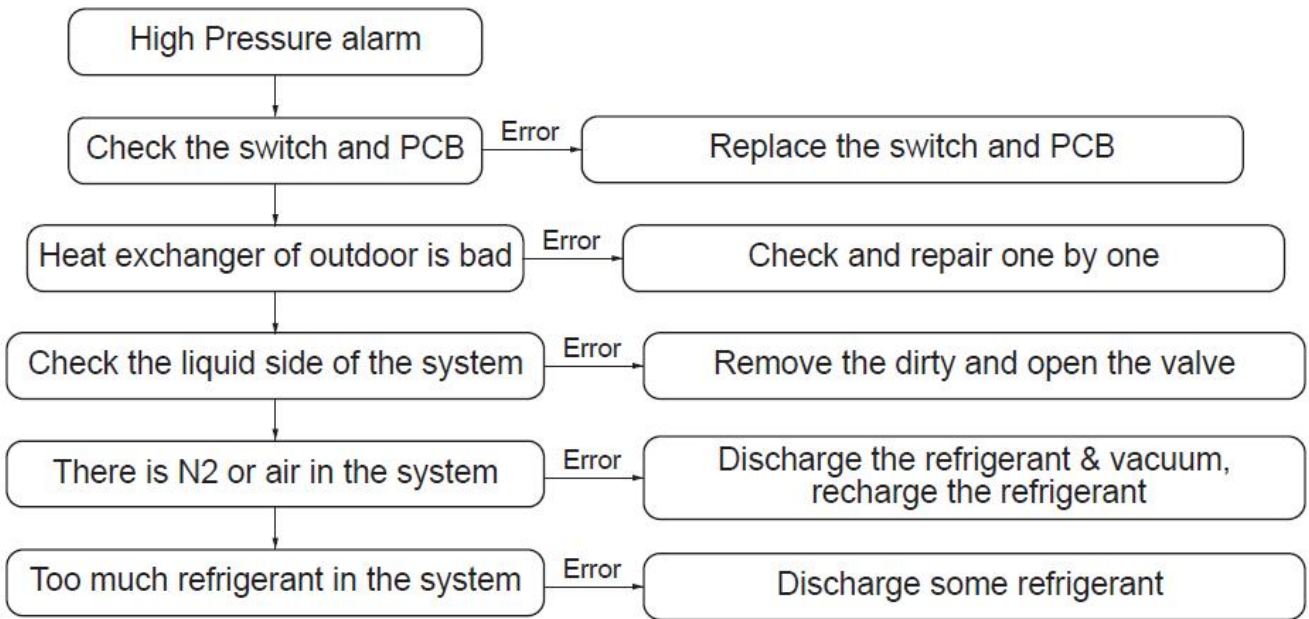

3.6 T3 high temperature protection

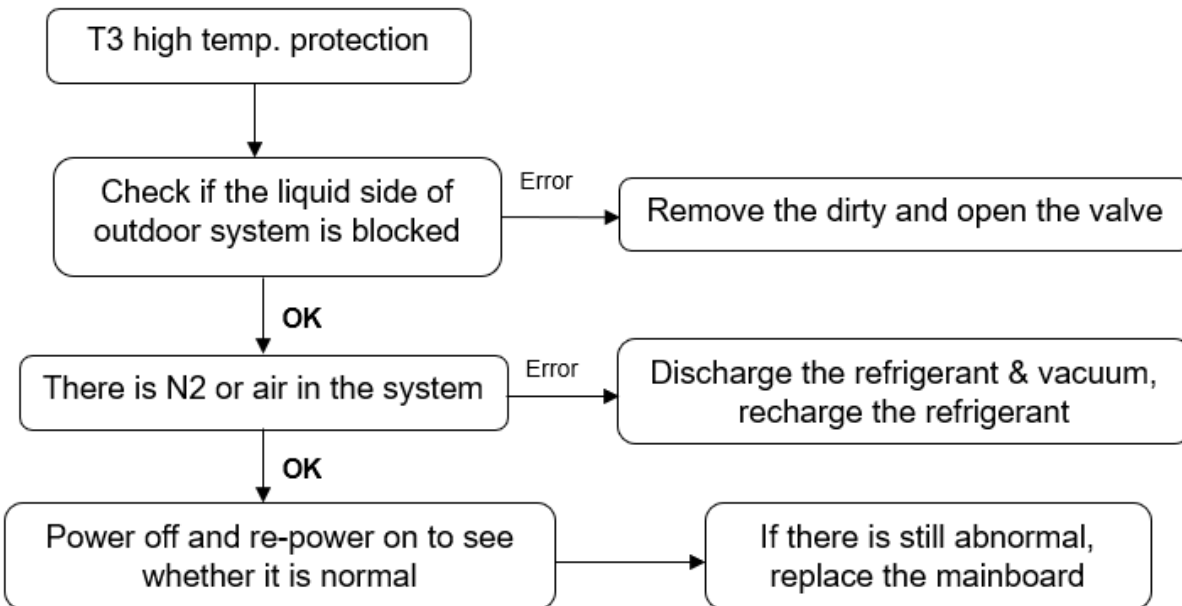

3.7 T5 high temperature protection

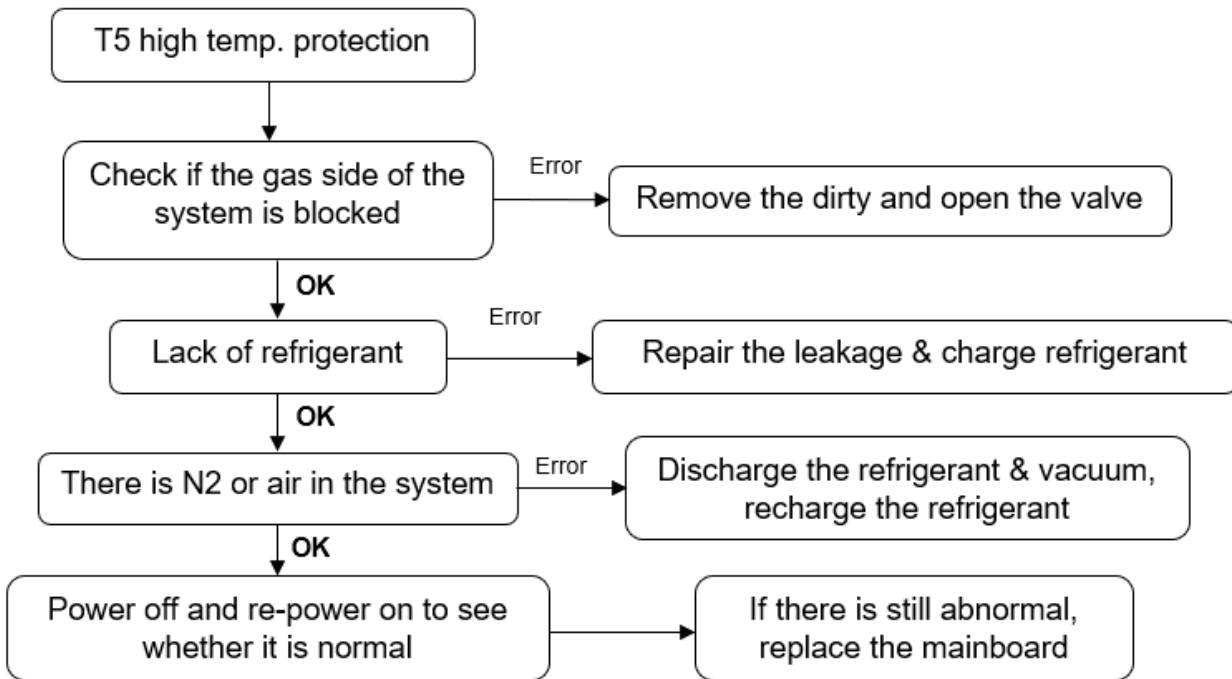

3.8 Fan motor feedback error

