

# CWM7(P),CWM7(E) Apartment Fan Coil Unit for R-454B Refrigerant

## Installation Instructions

**NOTE:** Read the entire instruction manual before starting the installation.

### Table of Contents

Safety Considerations . . . . .	1
Introduction . . . . .	1
Installation . . . . .	5
Check Equipment . . . . .	5
Mount Fan Coil . . . . .	5
Table 1 – Dimensional Data . . . . .	6
Ductwork Specifications . . . . .	7
Conversion to Bottom Return . . . . .	7
Condensate Drain . . . . .	7
Electrical Connections . . . . .	8
Select Proper Blower Speed . . . . .	8
TXV . . . . .	9
Leak Dissipation System . . . . .	9
Leak Dissipation System Self-Test . . . . .	9
Table 2 – Control Board Test Functions . . . . .	10
Table 3 – Required Minimum Dissipation Mode Airflows, based on Total System Refrigerant Charge Quantity . . . . .	10
Start-Up . . . . .	10
Sequence of Operation . . . . .	10
Table 4 – CWM7 (E) ECM Motor Speed Taps . . . . .	10
Continuous Fan . . . . .	10
Cooling Mode . . . . .	10
Heat Pump Heating Mode . . . . .	10
Heat Pump Heating with Auxiliary Electric Heat . . . . .	10
Electric Heat or Emergency Heat Mode . . . . .	10
Care and Maintenance . . . . .	11
Table 5 – Filter Sizes . . . . .	11
Refrigerant Charge and Room Area Limitations . . . . .	11
Table 6 – Minimum Opening Area for Connected Rooms . . . . .	12
Table 7 – Maximum Refrigerant Charge . . . . .	12
Table 8 – Required Minimum Room Area . . . . .	12
Table 9 – Minimum Circulation Airflow . . . . .	12
Electrical Wiring . . . . .	12
Ductwork . . . . .	13
Refrigerant Pipe-work . . . . .	14
Table 10 – PSC -Airflow Performance (Standard CFM) . . . . .	18
Table 11 – ECM - Airflow Performance (Standard CFM) . . . . .	18

### Safety Considerations

Improper installation, adjustment, alteration, service, maintenance, or use can cause explosion, fire, electrical shock, or other conditions which may cause death, personal injury or property damage. Consult a qualified installer, service agency, or your distributor or branch for information or assistance. The qualified installer or agency must use factory-authorized kits or accessories when modifying this product. Refer to individual instructions packaged with kits or accessories when installing.

Follow all safety codes. Wear safety glasses, protective clothing, and work gloves. Use quenching cloth for brazing operations. Have a fire extinguisher available. Read these instructions thoroughly and follow all warning or cautions included in literature and attached to the unit. Consult local building codes and the current editions of the National Electrical Code (NEC) NFPA 70.

In Canada, refer to the current editions of Canadian Electrical Code CSA C22.1.

Recognize safety information. This is the safety alert symbol . When you see this symbol on the unit and in instructions or manuals, be alert to the potential for personal injury. Understand the signal words **DANGER**, **WARNING**, and **CAUTION**. These words are used with the safety alert symbol. **DANGER** identifies the most serious hazards which will result in severe personal injury or death. **WARNING** signifies hazards which could result in personal injury or death. **CAUTION** is used to identify unsafe practices, which may result in minor personal injury or product and property damage. **NOTE** is used to highlight suggestions which will result in enhanced installation, reliability, or operation.

### Introduction

**CWM7(P), CWM7(E)** Fan Coils are designed with application flexibility in mind and are suitable for closet and flush mount installations. Units are available with field-installed electric heat with circuit breaker. Units are used indoors as the fan coil for split -system heat pumps or air conditioners.

The **CWM7(P)** uses a Fixed Orifice and a 3 Speed PSC Motor. **CWM7(E)** uses a TXV and a 5 speed multi-tap ECM motor for efficiency. Units are available in 18,000 through 36,000 Btuh nominal cooling capacities. Field-installed heaters are available in 5, 7.5, and 10 kW sizes. The coil is equipped with sweat-type connections and is vapor-charged with dry nitrogen. The casing is fully insulated to meet applications in conditioned space. Additional insulation is required if the unit is installed in unconditioned space. **NOTE:** Nuisance sweating may occur if the unit is installed in a humid location with low airflow.

Units are designed for upflow applications only. Local codes may limit this free-air-return type unit to installation in single-level applications.

**IMPORTANT:** These units are designed specifically for R-454B refrigerant and must be used only with compatible R-454B refrigerant air conditioners and heat pumps as shipped.

 **WARNING**



**PROPERTY OR PERSONAL INJURY HAZARD**

Risk of fire. Flammable refrigerant used.

To be repaired only by trained service personnel. Do not puncture refrigerant tubing.



Auxiliary devices which may be ignition sources shall not be installed in the ductwork, other than auxiliary devices listed for use with the specific appliance. See instructions.

Dispose of refrigerant properly in accordance with federal or local regulations.

Failure to follow proper R-454B dissipation system installation instructions can result in property damage, personal injury, or death. If any fault codes are listed, please troubleshoot to prevent system malfunction.

**! WARNING**

**PERSONAL INJURY / PROPERTY DAMAGE HAZARD**  
 Failure to follow this warning could result in property damage, personal injury, or death.  
 For continued performance, reliability, and safety, the only approved accessories and replacement parts are those specified by the equipment manufacturer. The use of non-manufacturer approved parts and accessories could invalidate the equipment limited warranty and result in fire risk, equipment malfunction, and failure. Please review manufacturer’s instructions and replacement part catalogs available from your equipment supplier.

**! WARNING**

**PROP 65 – LEAD EXPOSURE HAZARD**  
 This product can expose you to chemicals, including lead and lead compounds, which are known to the State of California to cause cancer and birth defects and other reproductive harm. For more information, go to [www.P65Warnings.ca.gov](http://www.P65Warnings.ca.gov).

Make sure the blower motor support is tight (3-motor mount bolts), then check to see if wheel is secured to motor shaft before operating unit.

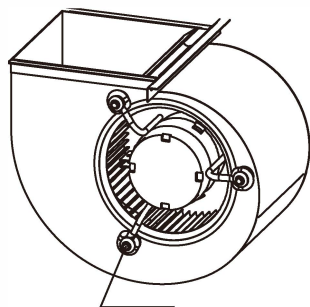

BLOWER MOTOR SHIPPING BOLT

Fig. 1 – Checking Motor Support Status

A240023

**! WARNING**

**PERSONAL INJURY / PROPERTY DAMAGE HAZARD**  
 Exposing combustible (non-metal) material to the supply opening of a downflow unit can cause a fire resulting in property damage, personal injury or death.  
 The first 6 inches of supply air plenum and ductwork must be constructed of sheet metal as required by NFPA 90B. The supply air plenum or duct must have a solid sheet metal bottom directly under the unit with no openings, registers or flexible air ducts located in it. If flexible supply air ducts are used, they may be located only in the vertical walls of rectangular plenum, a minimum of 6 inches from the solid bottom. Metal plenum or duct may be connected to the combustible floor base; if not, it must be connected to the unit supply duct exposed to the supply air opening from the downflow unit.

**! WARNING**

**PERSONAL INJURY / PROPERTY DAMAGE HAZARD**  
 Only use this unit in well-ventilated spaces and ensure that there are no obstructions that could impede the airflow into and out of the unit.  
 Do not use this unit in the following locations:

- Locations with mineral oil.
- Locations with saline atmospheres, such as seaside locations.
- Locations with sulphurous atmospheres, such as near natural hot springs.
- Where high voltage electricity is present, such as in certain industrial locations.
- On vehicles or vessels, such as trucks or ferry boats.
- Where exposure to oily or very humid air may occur, such as kitchens.
- In proximity to sources of electromagnetic radiation, such as high-frequency transmitters or other high strength radiation devices.

**! WARNING**

**PERSONAL INJURY / PROPERTY DAMAGE HAZARD**  
 Do not use means to accelerate the defrosting process or to clean, other than those recommended by the manufacturer.  
 The appliance shall be stored in a room that does not have continuously operating ignition sources (for example: open flames, an operating gas appliance or an operating electric heater).  
 Do not pierce or burn the unit.  
 Be aware that refrigerants may not contain an odor.

**! WARNING**

**PERSONAL INJURY / PROPERTY DAMAGE HAZARD**  
 This appliance is not intended for use by persons (including children) with reduced physical, sensory or mental capabilities, or persons who lack experience and knowledge, unless they are supervised or have been given instructions concerning the use of the appliance by a person responsible for their safety.  
 Children should be supervised to ensure that they do not play with the appliance.  
 Any person who is involved with working on or opening a refrigerant circuit should hold a current valid certificate from an industry accredited assessment authority, which authorizes their competence to handle refrigerants safely in accordance with an industry recognized assessment credential.  
 Servicing shall only be performed as recommended by the equipment manufacturer.  
 Maintenance and repair requiring the assistance of other skilled personnel shall be carried out under the supervision of a person competent in the use of flammable refrigerants.  
 Prior to beginning work on systems containing flammable refrigerants, safety checks are necessary to minimize the risk of ignition.

## **WARNING**

### **PERSONAL INJURY / PROPERTY DAMAGE HAZARD**

When repairing the refrigerating system, comply with the following precautions prior to conducting work on the system:

- shall be undertaken according to controlled procedures so as to minimize the risk of the presence of flammable gases or vapors while the work is being performed.
- All maintenance staff and others working in the local area shall be instructed on the nature of work being carried out. Work in confined spaces shall be avoided.
- The area shall be checked with an appropriate refrigerant detector prior to and during work, to ensure the technician is aware of potentially toxic or flammable environment.
- If any hot work is to be conducted on the refrigerating equipment or any associated parts, appropriate fire extinguishing equipment shall be available and easily accessible. Have a dry powder or CO fire extinguisher adjacent to the charging area.
- When carrying out work in relation to a refrigerating system that involves exposing any pipe work, no sources of ignition shall be used in such a manner that it may lead to the risk of fire or explosion. All possible ignition sources, including cigarette smoking, should be kept sufficiently far away from the site of installation, repair, or removal and disposal of the unit, during which refrigerant can possibly be released into the surrounding space. Prior to beginning work, the area around the equipment is to be surveyed to make sure that there are no flammable hazards or ignition risks. "No Smoking" signs shall be clearly displayed.

Ensure that the area is in the open or that it is adequately ventilated before opening the system or conducting any hot work. A degree of ventilation shall continue during the period that the work is carried out. The ventilation should safely disperse any released refrigerant and preferably expel it externally into the surroundings

Where electrical components are being changed, they shall be fit according to their purpose and to the correct specification. At all times the manufacturer's maintenance and service guidelines shall be followed. If in doubt, consult the manufacturer's technical department for assistance. The following checks shall be applied to installations using flammable refrigerants:

- The actual refrigerant charge is in accordance with the room size within which the refrigerant containing parts are installed.
- The ventilation machinery and outlets are operating adequately and are not obstructed.
- If an indirect refrigerating circuit is being used, the secondary circuit shall be checked for the presence of refrigerant.
- Equipment marking must remain visible and legible. Markings and signs that are illegible shall be corrected.

Refrigerating pipe or components are installed in a position where they are unlikely to be exposed to any substances which may corrode refrigerant containing components, unless the components are constructed of materials that are inherently resistant to corrosion or are suitably protected against corrosion.

Repair and maintenance of electrical components shall include initial safety checks and component inspection procedures. If a fault exists that could compromise safety, then no electrical supply shall be connected to the circuit until the fault has been dealt with satisfactorily. If the fault cannot be corrected immediately but it is necessary to continue operation, an adequate temporary solution shall be used. This

shall be reported to the owner of the equipment so that all parties are advised. Initial safety checks shall include:

- That capacitors are discharged: this shall be done in a safe manner to avoid the possibility of sparking.
- That no live electrical components and wiring are exposed while charging, recovering or purging the system.
- That there is continuity of grounding.

## **WARNING**

### **PERSONAL INJURY / PROPERTY DAMAGE HAZARD**

Sealed electrical components shall be replaced. Intrinsically safe components must be replaced. Check that cabling will not be subject to wear, corrosion, excessive pressure, vibration, sharp edges or any other adverse environmental effects. The check shall also take into account the effects of aging or continual vibration from sources such as compressors or fans. Under no circumstances shall potential sources of ignition be used while searching for or detection of refrigerant leaks. A halide torch (or any other detector using a naked flame) shall not be used. Electronic leak detectors may be used to detect refrigerant leaks but, in the case of flammable refrigerants, the sensitivity may not be adequate, or may need re-calibration. (Detection equipment shall be calibrated in a refrigerant-free area.) Ensure that the detector is not a potential source of ignition and is suitable for the refrigerant used. Leak detection equipment shall be set at a percentage of the LFL of the refrigerant and shall be calibrated for the refrigerant employed, and the appropriate percent age of gas (25% maximum) is confirmed. If a leak is suspected, all naked flames shall be removed/extinguished. If a leakage of refrigerant which requires brazing is found, all of the refrigerant shall be recovered from the system, or isolated (by means of shut off valves) in a part of the system remote from the leak. Leak detection fluids are also suitable for use with most refrigerants but the use of detergents containing chlorine shall be avoided as the chlorine may react with the refrigerant and corrode the copper pipe-work.

NOTE: Examples of leak detection fluids are:

- bubble method.

When breaking into the refrigerant circuit to make repairs or for any other purpose conventional procedures shall be used. However, for flammable refrigerants it is important that best practice be followed, since flammability is a consideration. The following procedure shall be adhered to:

- safely remove refrigerant following local and national regulations.
- evacuate.
- purge the circuit with inert gas.
- evacuate.
- continuously flush or purge with inert gas when using flame.
- open the circuit.

The refrigerant charge shall be recovered into the correct recovery cylinders if venting is not allowed by local and national codes. For appliances containing flammable refrigerants, the system shall be purged with oxygen-free nitrogen to render the appliance safe for flammable refrigerants. This process might need to be repeated several times. Compressed air or oxygen shall not be used for purging refrigerant systems. For appliances containing flammable refrigerants, refrigerants purging shall be achieved by breaking the vacuum in the system with oxygen-free nitrogen and continuing to fill until the working pressure is achieved, then venting to atmosphere, and finally pulling down to a vacuum. This process shall be repeated until no refrigerant is within the system. When the final oxygen-free nitrogen charge is used, the system shall be vented down to atmospheric pressure to enable work to take place. The outlet for the vacuum pump shall not be close to any potential ignition sources, and ventilation shall be available. Ensure that

**CWM7(P), CWM7(E): Installation Instructions**

contamination of different refrigerants does not occur when using charging equipment. Hoses or lines shall be as short as possible to minimize the amount of refrigerant they contain. Cylinders shall be kept upright. Ensure that the refrigeration system is grounded prior to charging the system with refrigerant. Label the system when charging is completed (if it is not already labeled). Take extreme care not to overfill the refrigeration system.

Prior to recharging the system, it shall be pressure-tested with the appropriate purging gas. The system shall be leak-tested on completion of charging but prior to commissioning. A follow up leak test shall be carried out prior to leaving the site. Before carrying out this procedure, it is essential that the technician is completely familiar with the equipment and all its detail. It is recommended that all refrigerants are recovered safely. Prior to the task being carried out, an oil and refrigerant sample shall be taken in case analysis is required prior to reuse of reclaimed refrigerant. It is essential that electrical power is available before the task is commenced.

- a. Become familiar with the equipment and its operation.
- b. Isolate system electrically.
- c. Before attempting the procedure ensure that:
  - (1.) mechanical handling equipment is available, if required, for handling refrigerant cylinders.
  - (2.) all personal protective equipment is available and being used correctly.
  - (3.) the recovery process is supervised at all times by a competent person.
  - (4.) recovery equipment and cylinders conform to the appropriate standards.
- d. Pump down refrigerant system, if possible.
- e. If a vacuum is not possible, make a manifold so that refrigerant can be removed from various parts of the system.
- f. Make sure that the cylinder is situated on the scales before recovery takes place.
- g. Start the recovery machine and operate it in accordance with the manufacturer's instructions.
- h. Do not overfill cylinders. (No more than 80% volume liquid charge).
- i. Do not exceed the maximum working pressure of the cylinder, even temporarily.
- j. When the cylinders have been filled correctly and the process has been completed, make sure that the cylinders and the equipment are removed from site promptly and all isolation valves on the equipment are closed off.
- k. Recovered refrigerant shall not be charged into another refrigeration system unless it has been cleaned and checked. Equipment shall be labeled stating that it has been de-commissioned and emptied of refrigerant. The label shall be dated and signed. Ensure that there are labels on the equipment stating the equipment contains flammable refrigerant. When removing refrigerant from a system, either for servicing or decommissioning, it is recommended that all refrigerants are removed safely.

When transferring refrigerant into cylinders, ensure that only appropriate refrigerant recovery cylinders are employed. Ensure that the correct number of cylinders for holding the total system charge is available. All cylinders to be used are designated for the recovered refrigerant and labelled for that refrigerant (i.e. special cylinders for the recovery of refrigerant). Cylinders shall be complete with pressure-relief valve and associated shut-off valves in good working order. Empty recovery cylinders are evacuated and, if possible, cooled before recovery occurs. The recovery equipment shall be in good working order with a set of instructions concerning the equipment that is at hand and shall be suitable for the recovery of the flammable refrigerant. If in doubt, the manufacturer should be consulted. In addition, a set of calibrated weighing scales shall be available and in good working order. Hoses

shall be complete with leak-free disconnect couplings and in good condition.

The recovered refrigerant shall be processed according to local legislation in the correct recovery cylinder, and the relevant waste transfer note arranged. Do not mix refrigerants in recovery units and especially not in cylinders.

If compressors or compressor oils are to be removed, ensure that they have been evacuated to an acceptable level to make certain that flammable refrigerant does not remain within the lubricant. The compressor body shall not be heated by an open flame or other ignition sources to accelerate this process. When oil is drained from a system, it shall be carried out safely.

Do not use the air conditioner for other purposes. In order to avoid any quality deterioration, do not use the unit for the cooling of precision instruments, food, plants, animals or works of art. Before cleaning, be sure to stop the operation, turn the breaker off or unplug the supply cord. Otherwise, electric shock and injury may occur.

In order to avoid electric shock or fire, make sure that an earth leak detector is installed. Never touch the air outlet or the horizontal blades while the swing flap is in operation.

Your fingers may become caught or the unit may break down.

Never put any objects into the air inlet or outlet.

Objects touching the fan at high speed can be dangerous.

Never inspect or service the unit by yourself.

Ask a qualified service person to perform this task.

Do not dispose of this product as unsorted municipal waste. This waste should be collected separately for special treatment. Do not dispose of electrical appliances as unsorted municipal waste. Use separate collection facilities. Contact your local government for information regarding the connection systems available.

If electrical appliances are disposed of in landfills or dumps, hazardous substances can leak into the groundwater and get into the food chain, harming your health and well-being.

To prevent refrigerant leak, contact your dealer.

When the system is installed and operates in a small room, it is required to maintain the concentration of the refrigerant below the limit, in case a leak occurs. Otherwise, oxygen in the room may be affected, resulting in a serious accident.

The refrigerant in the air conditioner is safe and normally does not leak.

If the refrigerant leaks into the room and comes into contact with the fire of a burner, a heater or a cooker, a harmful gas could be released. Turn off any combustible heating devices, ventilate the room, and contact the dealer where you purchased the unit.

Do not use the air conditioner until a service person confirms that the refrigerant leak is repaired.

Keep ventilation openings clear of obstruction.



Be sure the air conditioner is grounded. In order to avoid electric shock, make sure that the unit is grounded and that the earth wire is not connected to a gas or water pipe, lightning conductor or telephone earth wire.

Do not operate the air conditioner with a wet hands. An electric shock may happen.

Do not touch the heat exchanger fins. These fins are sharp and could cut you.

To avoid oxygen deficiency, ventilate the room sufficiently if equipment with a burner is used together with the air conditioner. Arrange the

drain hose to ensure smooth drainage. Incomplete drainage may cause wetting of the building, furniture, etc.

Never touch the internal parts of the controller.

Do not remove the front panel. Some parts inside are dangerous to touch, and machine troubles may occur.

Attention is drawn to the fact that additional transportation regulations may exist with respect to equipment containing flammable gas. The maximum number of pieces of equipment or the configuration of the equipment permitted to be transported together will be determined by the applicable transport regulations.

Signs for similar appliances used in a work area are generally addressed by local regulations and give the minimum requirements for the provision of safety and/or health signs for a work location. Storage package protection should be constructed such a way that mechanical damage to the equipment inside the package will not cause a leak of the REFRIGERANT CHARGE.

The maximum number of pieces of equipment permitted to be stored together will be determined by local regulations.

Do not operate the air conditioner when using a room fumigation type insecticide.

Failure to observe this precaution could cause the chemicals to become deposited in the unit, which could endanger the health of those who are hypersensitive to chemicals.

Do not place appliances which produce open flame in places exposed to the air flow from the unit or under the indoor unit. It may cause in complete combustion or deformation of the unit due to the heat. Do not install the air conditioner in a location where flammable gas may leak out. If the gas leaks out and stays around the air conditioner, a fire may break out.

**! WARNING**

**ELECTRICAL OPERATION HAZARD**

Failure to maintain proper clearances could result in personal injury or death.

Before installing or servicing unit, always turn off all power to unit. There may be more than 1 disconnect switch. Turn off accessory heater power if applicable.

**! CAUTION**

**CUT HAZARD**

Failure to follow this caution may result in personal injury. Sheet metal parts may have sharp edges or burrs. Use care and wear appropriate protective clothing, safety glasses and gloves when handling parts.

**! CAUTION**

**HOT TUBE WARNING**

Failure to follow this caution could result in personal injury and/or property damage. Refrigerant lines can reach or exceed 130 °F (54 °C). Avoid contact with the vapor header or vapor line, especially in Heating Mode. Do not service A2L refrigerant fan coils while these components are hot to avoid risk of ignition source.

## Installation

### Check Equipment

Unpack unit and move to final location. Remove carton, taking care not to damage unit. Remove protective sheet metal from the base of the unit, if equipped. Inspect equipment for damage prior to installation. File claim with shipping company if shipment is damaged or incomplete.

Locate rating plate on unit. It contains information needed to properly install unit. Check rating plate to be sure unit matches job specifications. A front access panel is provided, which permits access to blower assembly and electrical controls for removal and servicing.

**NOTE:** Minimum clearance of 21" (533 mm) is required in front of access panel for servicing only. Installation clearance from combustible materials is 0" (0 mm) from cabinet and supply-air duct (plenum included). Make sure there is adequate space on top of unit for refrigerant line connections and on bottom of unit for condensate trap (Fig. 2 and Fig. 3).

### Mount Fan Coil

#### Fan Coil Mounting Options

The fan coil comes standard with two different options for mounting: wall mount or frame mount. Both mounting options require the unit to be level from side to side and from front to back in order to allow condensate to properly drain from the unit. Failure to do this will result in condensate leaking out from the unit, potentially causing structural damage to the surrounding support structures, drywall, carpet, etc. around the unit. Also, both mounting structures require the ability to accommodate a minimum of load of 150 pounds. Failure to do this will cause damage to the support structure and potentially damage the unit.

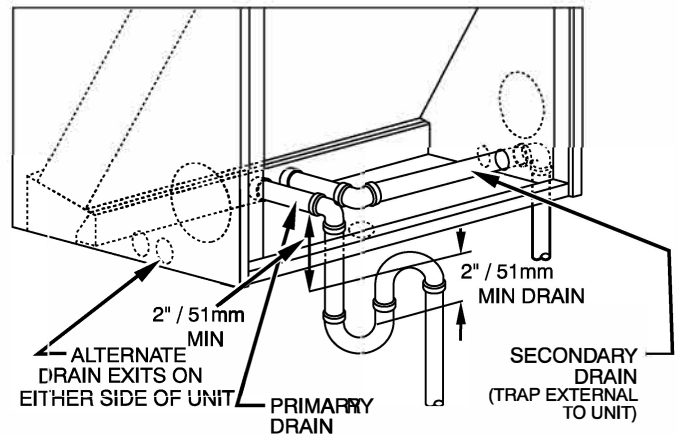

**NOTE:** Use plastic pipe from condensate pan to exterior of fan coil.

Fig. 2 – Condensate Drain

A13011

#### Wall Mount

The fan coil comes standard with a wall mounting bracket and fan coil mounting bracket. Refer to Fig. 4 for more detail.

1. Remove the wall mounting bracket from the back of the unit by removing one screw which attaches the bracket to the fan coil.

**NOTE:** Discard the screw after you have removed the wall mounting bracket.

2. Install bracket on the wall by using three wood screws (not provided) per wall-mount bracket. Make sure the bracket is level in order to provide proper drainage from the unit.

**NOTE:** Do not attach the wall mounting bracket into unsupported drywall. Make sure that the wood screws are going into a structure that can support a minimum load of 150 pounds.

3. Lift the fan coil above the wall mounting bracket and attach the unit to the installed bracket. Refer to Fig. 4.



**Frame Mount**

The fan coil comes with eight clearance holes, four on each side. These holes are used to mount the fan coil inside a frame structure (Fig. 5). When mounting in this fashion, make sure that the wood screws are mounted from within the fan coil and not outside of the unit. Installing the screws from outside of the unit may damage the coil. After moving unit into place, install refrigerant tubing as follows:

1. Route tubing to connection points, taking care not to block service access.
2. Remove plugs from liquid and vapor lines.
3. Braze connections using either silver bearing or non-silver bearing brazing material. Do not use soft solder (materials which melt below 800°F / 427°C). Consult local code requirements. Always flow nitrogen through the system refrigerant lines while brazing.
4. Pressurize system and leak-test. Repeat procedure until leak-free.

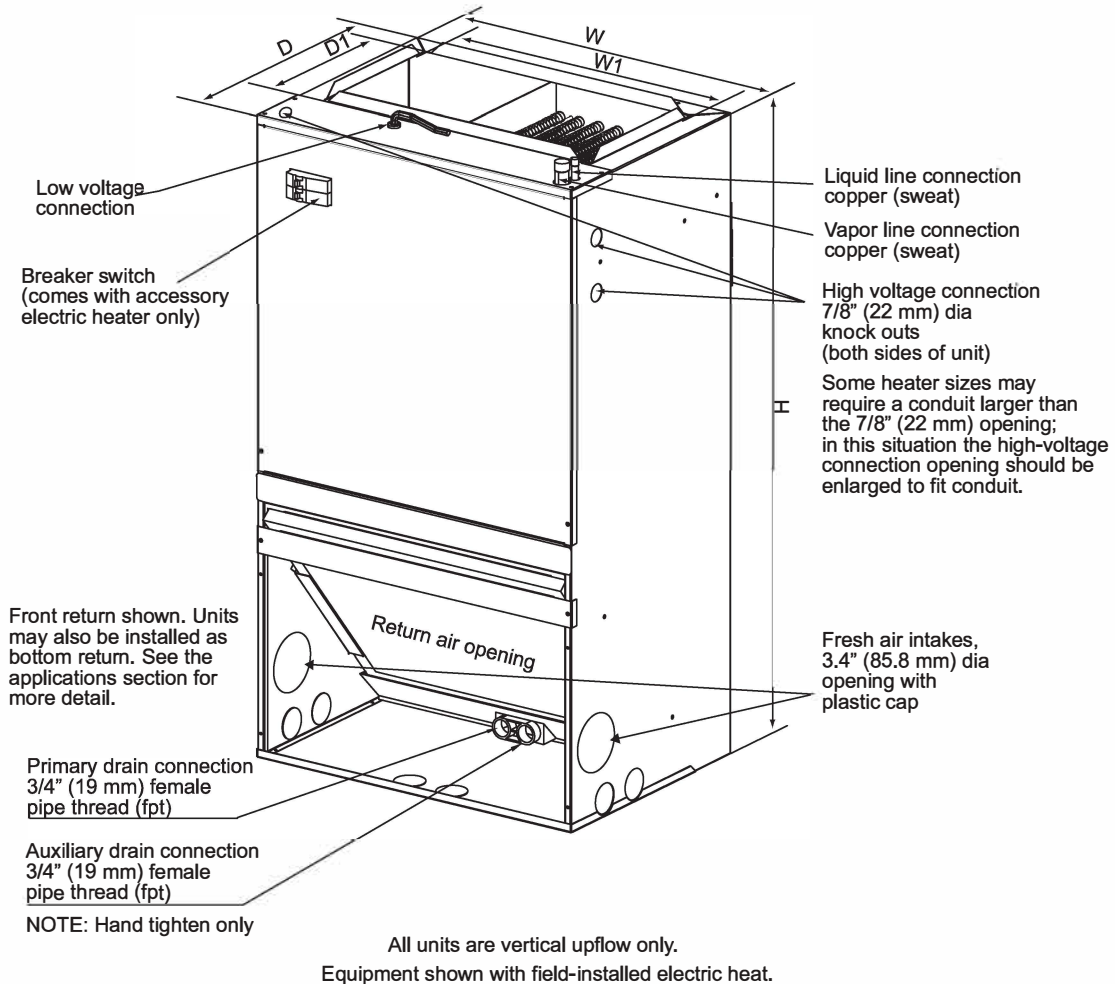

**Fig. 3 – Dimensional Drawing with Circuit Breaker**

A150161A

**Table 1 – Dimensional Data**

Model Size	Dimensions- In. (mm)					Unit Weight Lb. (kg)
	Unit Height H in. (mm)	Unit Width W in. (mm)	Unit Width W1 in. (mm)	Unit Depth D in. (mm)	Unit Depth D1 in. (mm)	
18	36-1/2 (928)	20-1/2 (521)	17-2/5 (442)	15 (381)	9-1/2 (242)	PSC motor – 88 (40) ECM motor – 84 (38)
24	36-1/2 (928)	20-1/2 (521)	17-2/5 (442)	15 (381)	9-1/2 (242)	PSC motor – 88 (40) ECM motor – 84 (38)
30	39-1/2 (1004)	22 (559)	18-4/5 (478)	19 (483)	9-1/2 (242)	PSC motor – 106 (48) ECM motor – 99 (45)
36	39-1/2 (1004)	22 (559)	18-4/5 (478)	19 (483)	9-1/2 (242)	PSC motor – 106 (48) ECM motor – 99 (45)

This appliance uses R-454B refrigerant.



A240024

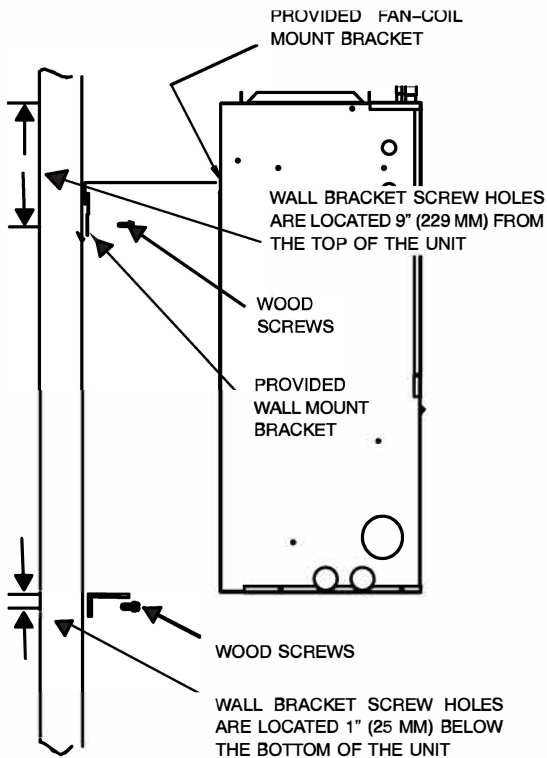

A190362

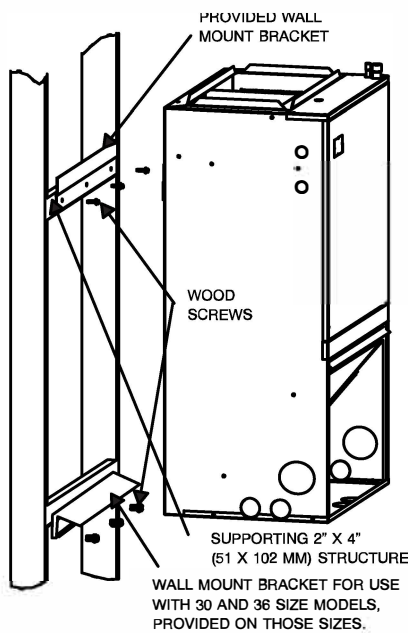

A190363

**Fig. 4 – Wall Mount Installation**

**NOTE:** Mounting wall and supporting structure must be able to support a minimum of 150 lbs. (68 kg)

**Ductwork Specifications**

Connect supply-air duct over 3/4" (19 mm) flange provided on supply-air opening. Secure duct to flange using applicable fasteners for type of duct used, and seal duct-to-unit joint.

**NOTE:** Short duct runs tend to increase noise level.

When fan coil is equipped with an electric heater, install air ducts in accordance with standards 90A and 90B of National Fire Protection Association (NFPA). Use of flexible connectors between ductwork and unit will prevent transmission of vibration. When electric heater is installed, use heat-resistant material for a flexible connector between

ductwork and unit air discharge connection. Ductwork passing through unconditioned space must be insulated and covered with a vapor barrier.

**NOTE:** Unit is intended for non-ducted return-air applications. Product Data sheet includes a list of accessories, including louvered wall panels and return air opening grills. If ducted return is used, airflow must meet criteria established in the Product Data. Local codes may limit this unit to single-level applications.

Design the duct system in accordance with "ACCA" Manual "D" Design for Residential Winter and Summer Conditioning and Equipment Selection. Latest editions are available from : "ACCA" Air Conditioning Contractors of America. If duct system incorporates flexible air duct, be sure pressure drop information (straight length plus all turns) shown in "ACCA" Manual "D" is accounted for in system.

**! WARNING**

**INJURY HAZARD**

Failure to follow this warning could result in personal injury or death. Do not, under any circumstances, connect return ductwork to any other heat-producing device such as fireplace inserts, stoves, etc. Unauthorized use of such devices may result in fire, carbon monoxide poisoning, explosion, personal injury or property damage.

**! CAUTION**

**ENVIRONMENTAL HAZARD**

Failure to follow this caution may result in environmental damage. Do not vent refrigerant to atmosphere. Recover during system repair or final unit disposal.

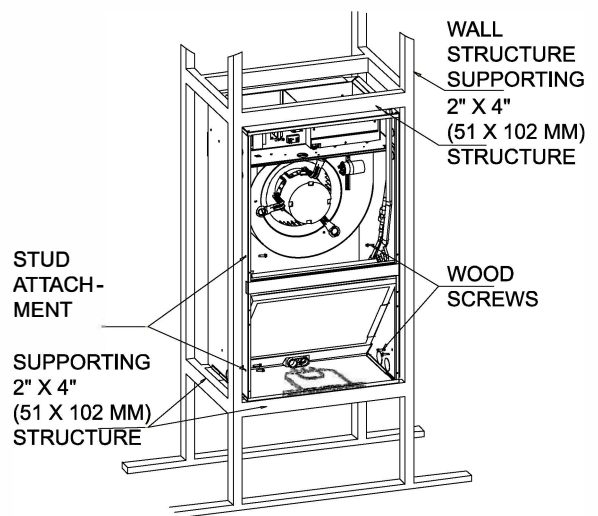

**Fig. 5 – Frame Mount Installation**

A13008A

**Conversion to Bottom Return**

This product is shipped configured for front return and can be converted for bottom return. To convert the unit to bottom return, remove the bottom panel and lower front panel (short panel above front opening and below the filter slot). Attach the panel removed from the bottom of the unit to the front return opening.

**Condensate Drain**

Condensate pan has primary and secondary drain connections to meet FHA requirements (Fig. 2). These connections have 3/4" (19 mm) female pipe threads. Tubing for all condensate drains should be a minimum of 7/8" (22 mm) OD. Drain lines from condensate pan to exterior of unit must be plastic pipe. Drain should be pitched downward

## CWM7(P), CWM7(E): Installation Instructions

at a slope of 1" per 10 feet (25 mm per 3 m). If coil is located in or above a living space where damage may result from condensate overflow, a separate 3/4" (19 mm) drain must be provided from secondary drain connection. Run this drain to a place in compliance with local installation codes where it will be noticed when unit is operational.

Condensate flow from secondary drain indicates a plugged primary drain. Install a 2" (51 mm) trap in condensate drain line as close to coil as possible. A factory approved drain trap kit is available. Make sure that the top of trap is below connection to drain pan to prevent condensate from overflowing drain pan. Prime all traps, test for leaks, and insulate in areas where sweating of the traps and drain lines could potentially cause water damage. Consult local codes for additional restrictions or precautions.

Optional extrusions are provided on the bottom panel if the installer wishes to secure the drain lines (Fig. 6).

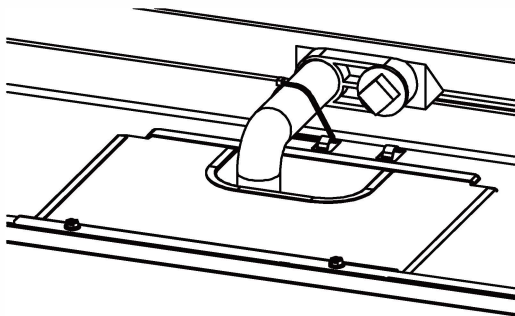

Fig. 6 – Drain Line Tie-down Extrusions

A230576

## Electrical Connections

Refer to unit wiring instructions for recommended wiring procedures. Use No. 18 AWG color-coded, insulated (35°C minimum) wire to make low-voltage connections between thermostat and unit. If thermostat is located more than 100 feet (30 m) from unit as measured along low-voltage wire, use No. 16 AWG color-coded, insulated (35°C minimum) wire.

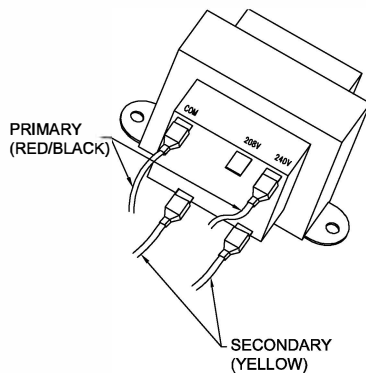

Fig. 7 – Transformer Connections

A13092A

**NOTE:** Before proceeding with electrical connections, make certain that voltage, frequency, and phase correspond to that specified on rating plate. Also, check to be sure that the service provided by utility is sufficient to handle additional load imposed by this equipment.

Refer to unit wiring label for proper field high- and low-voltage wiring. Make all electrical connections in accordance with NEC and any local codes or ordinances that might apply. Unit must have a separate branch electrical circuit.

**NOTE:** All units are shipped from factory wired for 240VAC transformer operation. For 208VAC operation, move primary lead from 240VAC terminal to 208VAC terminal.

See Fig. 11 and Fig. 12 for field low-voltage wiring. See Fig. 3 for location of the electrical inlets. For maximum ampacity and over-current protection, see unit rating plate or product data sheet.

1. Provide power supply for unit being installed in accordance with unit wiring diagram and rating plate.
2. Connect line-voltage leads to the harness pigtail or the heat-kit circuit breaker. Use copper wire only.

## ! WARNING

### ELECTRICAL OPERATION HAZARD

Failure to follow this warning could result in personal injury or death. Before installing or servicing the unit, always turn off all power to unit. There may be more than one disconnect switch. Turn off accessory heater power if applicable. Lock out and tag switch with a suitable warning label.

## ! WARNING

### ELECTRICAL SHOCK HAZARD

Failure to follow this warning could result in personal injury or death. Field wires on side of disconnect found in fan coil remain live, even when circuit breaker is off. Service and maintenance to incoming wiring cannot be performed until main disconnect switch (remote to the unit) is turned off. Lock out and tag switch with a suitable warning label.

Unit cabinet must have a continuous electrical path to ground in order to minimize potential for personal injury or death if an electrical fault should occur. This ground may consist of electrical wire or approved conduit when installed in accordance with existing codes. (See Item 3 below, regarding UL Listed Conduit.)

3. Use UL listed conduit and conduit connector for connecting line-voltage leads to unit and obtaining proper ground. If conduit connection uses reducing washers, a separate ground wire must be used. Grounding can also be accomplished by using the ground lug provided in the control box. Power wiring may be connected to either the right or left sides or top of unit. Knockouts of 7/8" (22 mm) dia. are provided for connection of power wiring to unit. Some heater sizes may require a conduit larger than the 7/8" opening; in this situation the high-voltage connection opening should be enlarged to fit the conduit. When removing the knockouts for electrical connections, an opening in the insulation should be cut to fit the opening. The cut edge of the insulation should be reinforced with foil tape to prevent fraying. The foil facing and insulation shall not be removed beyond the knockout opening size.
4. Install plastic grommet packed with unit in hole for low-voltage wires.
5. Connect low-voltage leads to thermostat and outdoor unit. See Fig. 11 and Fig. 12 as well as the outdoor unit wiring label.

**NOTE:** For field installed electric heat, the leads from the 6-pin connector (L1 and L2) will need to be disconnected so the electric heat can plug into that connector. Refer to Fig. 14 and Fig. 15, and the electric heat installation instructions for more details.

## Select Proper Blower Speed

Before operating unit, be sure that the proper blower speed has been selected. Fan speeds are selected manually using DIP switches on the control board. For both the CWM7(P) and CWM7(E), only the first 2 dip switches are used.

The dip switches on the CWM7(P) units are located in the lower left portion of the control board. (SW6)

- CWM7(P)18A1MN100B, dip switch 1 is set to ON, switch 2 is set to ON.
- CWM7(P)24A1MN100B, dip switch 1 is set to ON, switch 2 is set to OFF.



- CWM7(P)30B1MN100B, dip switch 1 is set to ON, switch 2 is set to ON.
- CWM7(P)36B1MN100B, dip switch 1 is set to ON, switch 2 is set to ON.
- SW6 dip switches 3 and 4 are not used and should remain set to OFF. The dip switches for the CWM7(E) units are the lower of the two sets of 4 dip switches located in the upper right area of the control board.

(SW6)

- CWM7(E) 18A1MN10TB, dip switch 1 is set to OFF, switch 2 is set to ON.
- CWM7(E) 24A1MN10TB, dip switch 1 is set to ON, switch 2 is set to ON.
- CWM7(E)30B1MN10TB, dip switch 1 is set to OFF, switch 2 is set to ON.
- CWM7(E)30B1MN10TB, dip switch 1 is set to ON, switch 2 is set to OFF.
- SW6 dip switches 3 and 4 are not used and should remain set to OFF.
- SW7 dip switches are not used and should remain set to OFF.

To change the fan speed on model MHVP, refer to Fig. 15.

To change the fan speed on model CWM7(E), refer to Fig. 14.

#### 14. TXV

**NOTE:** The TXVs are preset at the factory and do not need adjustment for reliable operation.

**! WARNING**

**PERSONAL INJURY OR PROPERTY DAMAGE**

These instructions are exclusively intended for qualified contractors and authorized installers.

Work on the refrigerant circuit with flammable refrigerant in safety group A2L may only be carried out by authorized heating contractors. These heating contractors must be trained in accordance with UL 60335-2-40, Section HH. The certificate of competence from an industry accredited body is required.

Work on electrical equipment may only be carried out by a qualified electrician.

Before initial commissioning, all safety related points must be checked by the particular certified heating contractors. The system must be commissioned by the system installer or a qualified person authorized by the installer.

For installation of the indoor unit, refer to the corresponding installation and operation manual. If an indoor unit is installed in an unventilated area, the area shall be so constructed that should any refrigerant leak, it will not stagnate so as to create a fire or explosion hazard.

The appliance shall be stored so as to prevent mechanical damage from occurring.

Do not stack combustible materials on the surface of the indoor unit.

### Leak Dissipation System

**! WARNING**

**PERSONAL INJURY OR PROPERTY DAMAGE HAZARD**

Failure to follow proper R-454B mitigation system installation instructions can result in property damage, personal injury, or death.

If any fault codes are listed, please troubleshoot to prevent system malfunction.

The units come equipped with a factory wired R-454B leak detection and dissipation system to ensure safe operation during a leak. The system consists of a bracket, a PCB, a A2L Detection Sensor, and a drain pan clip. Failure to install this system will result in potentially hazardous conditions and improper equipment operation, and void all system warranties and liabilities.

All units are shipped with the A2L Detection Sensor located on the back side of the slope coil (Fig. 8).

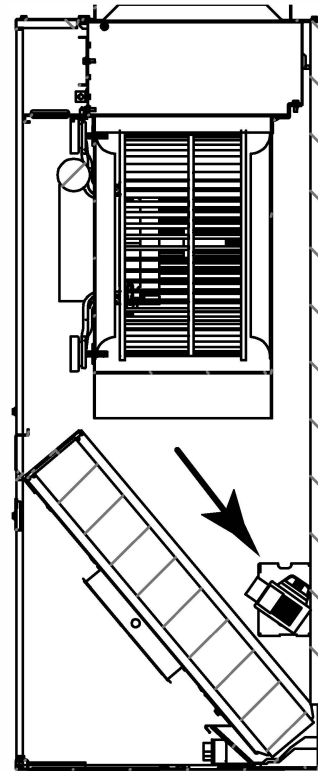

**Fig. 8 – Location of Dissipation Sensor**

A230605

The A2L Detection Sensor is attached to a wiring harness that connects the sensor to the control board. Refer to Fig. 11 and Fig. 12 for low voltage field connections between the control board and the thermostat. All control wires are labeled with the wire function and landing point.

### Leak Dissipation System Self-Test

Power on the unit and verify proper functioning of equipment. The green LED on the control board should be steady (Fig. 9). If flash codes are present, see Table 2.

**! WARNING**

**LEAK DETECTION SYSTEM** is installed on indoor unit. Unit must be powered except for service. Continuous air circulation required for proper functioning. Unit must be powered except for service. This unit is equipped with electrically powered safety measures. To be effective, the unit must be electrically powered at all times after installation, other than when servicing.

## ! CAUTION

The refrigerant leakage sensor can only use the factory model or the specified model indicated in the corresponding manual.

The R454B refrigerant leakage sensor must be used to activate the refrigerant shut-off device, the alarm device, incorporated circulation airflow or other emergency controls, which shall give an electrical signal at a predetermined alarm set point in response to leaked refrigerant.

The location of leakage sensors shall be chosen in relation to the different installation scenarios. Please refer to the indoor unit installation manual for specific requirements.

The installation of the refrigerant leakage sensor shall allow access for checking, repair or replacement by an authorized person.

The refrigerant leakage sensor shall be installed so its function can be verified easily.

The refrigerant leakage sensor shall be protected to prevent tampering or unauthorized resetting of the pre-set value.

To be effective, the refrigerant leakage sensor must be electrically powered at all times after installation, other than when servicing.

If the refrigerant leakage sensor detects a refrigerant leak, the fan will be turned on to the maximum, the compressor will stop running. You should immediately leave the leak area and notify a professional for handling.

The service life of the refrigerant sensor is 15 years, and it should be replaced after the service life or if the sensor is determined to be faulty during the service life.

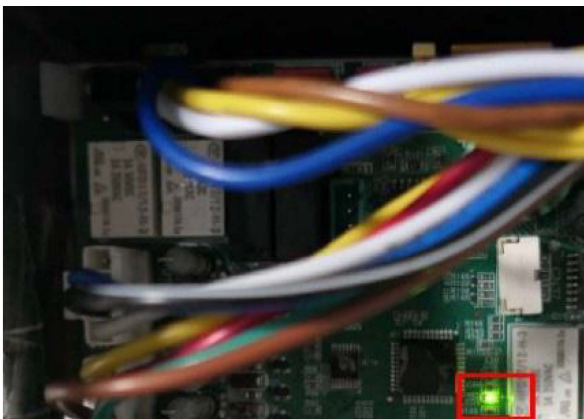

A230606

Fig. 9 – Control Board LED

Table 2 – Control Board Test Functions

LED Status	Description
Steady ON	Normal Operation
OFF	Power Supply Failure
Steady Flashing	Dissipation Mode Active
3 Flash / Cycle	A2L Sensor Error
4 Flash / Cycle	A2L Sensor Communication Error
8 Flash / Cycle	A2L Sensor Over Service Life

Ensure that the fan coil is able to meet the minimum required dissipation mode airflows. These required minimum airflow rates during Dissipation Mode are listed in Table 3. They are based on the total system refrigerant charge quantity.

Table 3 – Required Minimum Dissipation Mode Airflows, based on Total System Refrigerant Charge Quantity

Total System Charge		Minimum Required Dissipation		Total System Charge		Minimum Required Dissipation	
lb	kg	CFM	m³/h	lb	kg	CFM	m³/h
5	2.2	133	225.9	16	7.2	426	723.7
6	2.7	160	271.8	17	7.7	452	767.9
7	3.1	186	316.0				
8	3.6	213	361.8				
9	4.0	239	406.0				
10	4.5	266	451.9				
11	4.9	293	497.8				
12	5.4	319	541.9				
13	5.8	346	587.8				
14	6.3	372	632.0				
15	6.8	399	677.9				

### Start-Up

Refer to outdoor unit Installation Instructions for system start-up instructions and refrigerant charging method details.

### Sequence of Operation

**NOTE:** The following sequence of operation is based on units installed with PSC motor and Time Delay Board (TDB). For units with ECM motor, the off-delay is programmed into the motor. Follow Table 4, ECM Motor Speed Taps & the corresponding blower off delays for each speed tap.

Table 4 – CWM7(E) ECM Motor Speed Taps

Tap	Delay-off Time (s)	18	24	30	36
Tap 1	30	-	-	-	-
Tap 2	30	-	-	-	-
Tap 3	90	Default	-	Default	-
Tap 4	90	-	-	-	Default
Tap 5	90	-	Default	-	-

### Continuous Fan

Thermostat closes R to G. G energizes and completes circuit to indoor blower motor. When G is de-energized, there is a 90's blower off-delay.

### Cooling Mode

Thermostat energizes R to G, and R to Y. G energizes and completes indoor blower motor. Y energizes outdoor unit. When cooling call is satisfied, G is de-energized, and there is a 90-second blower-off delay.

### Heat Pump Heating Mode

Thermostat energizes R to G and R to Y and R to O/B (heat pump only). G energizes and completes circuit to indoor blower motor. Y energizes outdoor unit (O/B is energized for heat pump). When heating call is satisfied, G is de-energized, and there is a 90-second blower-off delay.

### Heat Pump Heating with Auxiliary Electric Heat

Thermostat energizes R to G, R to Y, and R to W1. G energizes and completes circuit to indoor blower motor. W1 energizes electric heat relay(s) which completes circuit to heater element(s). When W1 is de-energized, electric heat relay(s) open, turning off heater elements. When G is de-energized there is a 90s blower off-delay.

### Electric Heat or Emergency Heat Mode

Thermostat energizes R to W1. W1 energizes electric heat relay(s) which completes circuit to heater element(s). Blower motor is energized through normally closed contacts on fan relay. When W1 is

de-energized, electric heat relay(s) opens, the ECM motor will have blower off-delay based on motor speed tap selection.

### Care and Maintenance

For continuing high performance and to minimize possible equipment failure, it is essential that periodic maintenance be performed on this equipment. The only required maintenance that may be performed by the consumer is filter maintenance. See Table 5.

**Table 5 – Filter Sizes**

Unit Size	Filter Size In. (mm)
18, 24	16 x 20 x 1 (406 x 508 x 25)
30, 36	20 x 20 x 1 (508 x 508 x 25)

The minimum maintenance requirements for this equipment are as follows:

1. Inspect and clean or replace air filter each month or as required.
2. Inspect cooling coil, drain pan, and condensate drain each cooling season for cleanliness. Clean as necessary.
3. Inspect blower motor and wheel for cleanliness each heating and cooling season. Clean as necessary.
4. Inspect electrical connections for tightness and controls for proper operation each heating and cooling season. Service as necessary.

**NOTE:** The installing technician should explain system operation to the consumer with particular emphasis on indoor fan coil operation sounds and filter maintenance. The filter must meet the requirements of UL900.

### Refrigerant Charge and Room Area Limitations

In UL/CSA 60335-2-40, R454B refrigerant is classified as class A2L, which is mildly flammable. Therefore, R454B refrigerant is suitable for systems needing additional refrigerant charge and which will limit the space of the rooms being served by the system.

Similarly, the total amount of refrigerant in the system shall be less than or equal to the allowable maximum refrigerant charge. The allowable maximum refrigerant charge depends on the space of the rooms being served by the system.

**NOTE:** The nouns in the table are explained as follows:

- Mc: the actual refrigerant charge in the system.
- A: the actual room area where the appliance is installed.
- Amin: the required minimum room area.
- Mmax: the allowable refrigerant charge in a room.
- Qmin: the minimum circulation airflow.
- Anvmin: The minimum opening area for connected rooms.

### Room Area Calculation Requirements

**NOTE:** The space considered shall be any space which contains refrigerant-containing parts or into which refrigerant could be released. The room area (A) of the smallest, enclosed, occupied space shall be used in the determination of the refrigerant quantity limits.

For determination of room area (A) when used to calculate the refrigerant charge limit, the following shall apply. The room area (A) shall be defined as the room area enclosed by the projection to the base of the walls, partitions and doors of the space in which the appliance is installed. Spaces connected by only drop ceilings, ductwork, or similar connections shall not be considered a single space. Units mounted higher than 71" (1.8m) and spaces divided by partition walls that are no higher than 63" (1.6m) shall be considered a single space. Rooms on the same floor and connected by an open passageway between the spaces can be considered a single room when determining compliance to Amin, if the passageway complies with all of the following.

1. It is a permanent opening.
2. It extends to the floor.
3. It is intended for people to walk through.

The area of the connected rooms, on the same floor, connected by permanent opening in the walls and/or doors between occupied spaces,

including gaps between the wall and the floor, can be considered a single room when determining compliance to Amin, provided all of the following conditions are met as Fig. 10.

1. Low level opening
  - a. The opening shall not be less than Anvmin in Table 6.
  - b. The area of any openings above 11-3/16" (300mm) from the floor shall not be considered in determining compliance with Anvmin.
  - c. At least 50% of the opening area of Anvmin shall be below 7-7/8" (200mm) from the floor.
  - d. The bottom of the opening is not more than 100mm from the floor.
  - e. The opening is a permanent opening that cannot be closed.
  - f. For openings extending to the floor the height shall not be less than 7-7/8" (200mm) above the surface of the floor covering.
2. High level opening
  - a. The opening shall not be less than 50% of Anvmin in Table 6.
  - b. The opening is a permanent opening that cannot be closed.
  - c. The opening shall be at least 59" (1.5m) above the floor.
  - d. The height of the opening is not less than 20 mm.
3. Room size requirement
  - a. The room into which refrigerant can leak, plus the connected adjacent room(s) shall have a total area not less than Amin. Amin shown in Table 7 or Table 9 under different conditions.
  - b. The room area in which the unit is installed shall be not less than 20% Amin. Amin is shown in Table 7 or Table 9 under different conditions.

**NOTE:** The requirement for the second opening can be met by drop ceilings, ventilation ducts, or similar arrangements that provide an airflow path between the connected rooms.

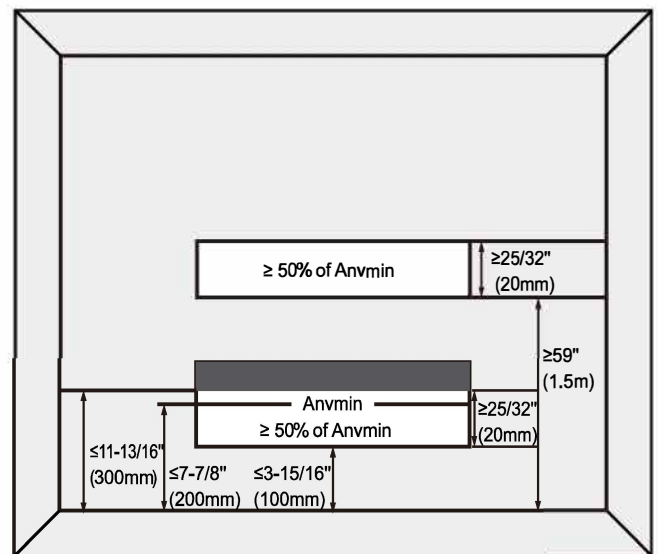

**Fig. 10 – Opening Conditions for Connected Rooms**

A240025

For appliances serving one or more rooms with an air duct system, the room area calculation shall be determined based on the total area of the conditioned space (TA) connected by ducts taking into consideration that the circulating airflow distributed to all the rooms by the appliance integral indoor fan will mix and dilute the leaking refrigerant before entering any room.

**Table 6 – Minimum Opening Area for Connected Rooms**

A		Mc		Mmax		Anvmin	
ft <sup>2</sup>	m <sup>2</sup>	lb-oz	kg	lb-oz	kg	ft <sup>2</sup>	m <sup>2</sup>
100	9.3	17-3	7.8	6-10	3.0	1.3	0.14
110	10.2	17-3	7.8	7-5	3.3	1.2	0.13
120	11.1	17-3	7.8	8-0	3.6	1.1	0.12
130	12.1	17-3	7.8	8-10	3.9	1.0	0.11
140	13.0	17-3	7.8	9-5	4.2	1.0	0.11
150	13.9	17-3	7.8	10-0	4.5	0.9	0.10
160	14.9	17-3	7.8	10-10	4.8	0.8	0.09
170	15.8	17-3	7.8	11-5	5.1	0.7	0.08
180	16.7	17-3	7.8	12-0	5.4	0.6	0.07
190	17.7	17-3	7.8	12-10	5.7	0.5	0.06
200	18.6	17-3	7.8	13-5	6.0	0.5	0.06
210	19.5	17-3	7.8	14-0	6.4	0.4	0.04
220	20.4	17-3	7.8	14-10	6.6	0.3	0.03
230	21.4	17-3	7.8	15-5	6.9	0.2	0.02
240	22.3	17-3	7.8	16-0	7.3	0.1	0.01
250	23.2	17-3	7.8	16-10	7.5	0.1	0.01
260	24.2	17-3	7.8	17-5	7.9	0.0	0.00

**The Maximum Refrigerant Charge and Minimum Room Area**

If the fan incorporated to an appliance is continuously operated or operation is initiated by a REFRIGERANT DETECTION SYSTEM with a sufficient CIRCULATION AIRFLOW rate, the maximum refrigerant charge (Mmax) and the required minimum room area (Amin) is shown in Table 7 and Table 8.

**Table 7 – Maximum Refrigerant Charge**

A/TA		Mmax		A/TA		Mmax	
ft <sup>2</sup>	m <sup>2</sup>	lb-oz	kg	ft <sup>2</sup>	m <sup>2</sup>	lb-oz	kg
40	3.7	2-10	1.2	160	14.9	10-10	4.8
50	4.6	3-5	1.5	170	15.8	11-5	5.1
60	5.6	4-0	1.8	180	16.7	12-0	5.4
70	6.5	4-10	2.1	190	17.7	12-10	5.7
80	7.4	5-5	2.4	200	18.6	13-5	6.0
90	8.4	6-0	2.7	210	19.5	14-0	6.3
100	9.3	6-10	3.0	220	20.4	14-10	6.6
110	10.2	7-5	3.3	230	21.4	15-5	6.9
120	11.1	8-0	3.6	240	22.3	16-0	7.2
130	12.1	8-10	3.9	250	23.2	16-10	7.5
140	13.0	9-5	4.2	260	24.2	17-5	7.8
150	13.9	10-0	4.5				

**Table 8 – Required Minimum Room Area**

Mc		Amin/Tamin		Mc		Amin/Tamin	
lb-oz	kg	ft <sup>2</sup>	m <sup>2</sup>	lb-oz	kg	ft <sup>2</sup>	m <sup>2</sup>
4-6	2.0	66.1	6.1	11-0	5.0	165.3	15.4
4-13	2.2	72.7	6.8	11-7	5.2	171.9	16.0
5-4	2.4	79.3	7.4	11-14	5.4	178.5	16.6
5-11	2.6	86.0	8.0	12-5	5.6	185.1	17.2
6-2	2.8	92.6	8.6	12-12	5.8	191.7	17.8
6-9	3.0	99.2	9.2	13-3	6.0	198.4	18.4
7-0	3.2	105.8	9.8	13-10	6.2	205.0	19.0
7-7	3.4	112.4	10.4	14-1	6.4	211.6	19.7
7-15	3.6	119.0	11.1	14-8	6.6	218.2	20.3
8-6	3.8	125.6	11.7	14-15	6.8	224.8	20.9

**Table 8 – (Continued) Required Minimum Room Area**

Mc		Amin/Tamin		Mc		Amin/Tamin	
lb-oz	kg	ft <sup>2</sup>	m <sup>2</sup>	lb-oz	kg	ft <sup>2</sup>	m <sup>2</sup>
8-13	4.0	132.2	12.3	15-6	7.0	231.4	21.5
9-4	4.2	138.8	12.9	15-14	7.2	238.0	22.1
9-11	4.4	145.5	13.5	16-5	7.4	244.6	22.7
10-2	4.6	152.1	14.1	16-12	7.6	251.2	23.3
10-9	4.8	158.7	14.7	17-3	7.8	257.9	24.0

**Table 9 – Minimum Circulation Airflow**

Mc		Amin/Tamin		Mc		Amin/Tamin	
lb-oz	kg	CFM	m <sup>3</sup> /h	lb-oz	kg	CFM	m <sup>3</sup> /h
4-6	2.0	119	202.3	11-0	5.0	298	506.6
4-13	2.2	131	222.7	11-7	5.2	310	527.0
5-4	2.4	143	243.1	11-14	5.4	322	574.4
5-11	2.6	155	263.5	12-5	5.6	334	567.8
6-2	2.8	167	283.9	12-12	5.8	346	588.2
6-9	3.0	179	304.3	13-3	6.0	358	608.6
7-0	3.2	191	324.7	13-10	6.2	370	629.0
7-7	3.4	203	345.1	14-1	6.4	382	649.4
7-15	3.6	215	365.5	14-8	6.6	394	669.8
8-6	3.8	227	385.9	14-15	6.8	406	690.2
8-13	4.0	239	406.3	15-6	7.0	418	710.6
9-4	4.2	251	426.7	15-14	7.2	430	731.0
9-11	4.4	263	447.1	16-5	7.4	442	751.4
10-2	4.6	275	467.5	16-12	7.6	454	771.8
10-9	4.8	287	487.9	17-3	7.8	466	792.2

**Table 10 – Refrigerant Charge Limit**

Model(Size, Ton)	Qv/m <sup>3</sup> /h	Mc/kg
PSC18	408	4.0256
PSC24	609	6.0088
ECM18	534	5.2688
ECM24	609	6.0088

**NOTE:** The maximum refrigerant charge of Table 7 or the required minimum room area of Table 8 is available only if the following conditions are met: Minimum velocity of 1m/s<sup>2</sup>, which is calculated as the indoor unit airflow divided by the nominal face area of the outlet. And the grill area shall not be deducted. Minimum airflow rate must meet the corresponding values in Table 1-5, which is related to the actual refrigerant charge of the system (Mc). R-454B refrigerant leakage sensor is configured.

**NOTE:** The maximum refrigerant limit described above applies to unventilated areas. If adding additional measures, such as areas with mechanical ventilation or natural ventilation, the maximum refrigerant charge can be increased or the minimum room area can be reduced. If the R-454B refrigerant leakage sensor is configured for the indoor unit, and meets the incorporated circulation airflow requirements, the maximum refrigerant charge or minimum room area can be determined according to Table 7 or Table 8.

**NOTE:** Due to the airflow requirement, the refrigerant charge of some products should not exceed Table 10.

**NOTE:** If the actual room area, outlet height, and refrigerant charge amount are not reflected in the above table, more severe cases need to be considered according to the data in the table.



## Electrical Wiring

Field wiring must comply with the National Electric Code (C.E.C. in Canada) and any applicable local ordinance.

### WARNING

#### **ELECTROCUTION HAZARD**

Disconnect all power to unit before installing or servicing. More than one disconnect switch may be required to de-energize the equipment. Hazardous voltage can cause severe personal injury or death.

### Control Wiring

**IMPORTANT:** Class 2 low voltage control wiring should not be run in conduit with main power wiring and must be separated from power wiring, unless class 1 wire of proper voltage rating is used.

Low voltage control wiring should be 18 Awg. color-coded. For lengths longer than 100 ft., 16 Awg. wire should be used.

Low voltage control connections are made to low voltage pigtailed extending from top of unit.

Connections for control wiring are made with wire nuts. Control wiring knockouts (5/8" and 7/8") are also provided on the right and left side of the unit for side connection.

See wiring diagrams attached to indoor and outdoor sections to be connected. Make sure, after installation, that separation of control wiring and power wiring has been maintained.

### Power Wiring

It is important that proper electrical power is available for connection to the unit model being installed. See the unit nameplate wiring diagram and electrical data in the installation instructions.

If required, install a branch circuit disconnect of adequate size, located within sight of, and readily accessible to the unit.

**IMPORTANT:** After the Electric Heater is installed, units may be equipped with one two or three 30-60 amp. circuit breakers. These breaker(s) protect the internal wiring in the event of a short circuit and serve as a disconnect. Circuit breakers installed within the unit do not provide over-current protection of the supply wiring and therefore may be sized larger than the branch circuit protection.

**NOTE:** The indoor unit air switch cannot be used as a circuit breaker and cannot be operated by users. Maintenance personnel need to disconnect the main switch before operation.

Supply circuit power wiring must be 75°C minimum copper conductors only. See Electrical Data in this section for ampacity, wire size and circuit protector requirement. Supply circuit protective devices may be either fuses or "HACR" type circuit breakers.

Power wiring may be connected to either the right, left side or top. Three 7/8", 1-3/8", 1-3/4" dia. concentric knockouts are provided for connection of power wiring to unit.

Power wiring is connected to the power terminal block in unit electric cabinet.

### WARNING

#### **SHOCK HAZARD**

The unit must be permanently grounded. Failure to do so can result in electrical shock causing personal injury or death.

Grounding may be accomplished by grounding metal conduit when installed in accordance with electrical codes to the unit cabinet.

Grounding may also be accomplished by attaching ground wire(s) to ground lug(s) provided in the unit wiring compartment.

Ground lug(s) are located close to wire entrance on left side of unit (up-flow). Lug(s) may be moved to marked locations near wire entrance on right side of unit (up-flow). If alternate location is more convenient.

Use of multiple supply circuits require grounding of each circuit to lug(s) provided in unit.

### **Ductwork**

Field ductwork must comply with the National Fire Protection Association NFPA 90A, NFPA 90B and any applicable local ordinance.

### WARNING

#### **PERSONAL INJURY HAZARD**

Do not, under any circumstances, connect return ductwork to any other heat producing device such as fireplace insert, stove, etc. Unauthorized use of such devices may result in fire, carbon monoxide poisoning, explosion, personal injury or property damage.

Sheet metal ductwork in unconditioned spaces must be insulated and covered with a vapor barrier. Fibrous ductwork may be used if constructed and installed in accordance with SMACNA Construction Standard on Fibrous Glass Ducts. Ductwork must comply with National Fire Protection Association as tested by UL Standard 181 for Class I Air Ducts. Check local codes for requirements on ductwork and insulation. Duct system must be designed within the range of external static pressure the unit is designed to operate against. It is important that the system airflow be adequate. Make sure supply and return ductwork, grills, special filters, accessories, etc. are accounted for in total resistance. See airflow performance tables in this manual.

Design the duct system in accordance with "ACCA" Manual "D" Design for Residential Winter and Summer Air Conditioning and Equipment Selection. Latest editions are available from: "ACCA" Air Conditioning Contractors of America, 1513 16th Street, N.W., Washington, D.C. 20036. If duct system incorporates flexible air duct, be sure pressure drop information (straight length plus all turns) shown in "ACCA" Manual "D" is accounted for in the system.

Supply plenum is attached to the 3/4" duct flanges supplied with the unit. Attach flanges around the blower outlet.

**IMPORTANT:** If an elbow is included in the plenum close to the unit, it can not be smaller than the dimensions of the supply duct flange on the unit.

**IMPORTANT:** The front flange on the return duct if connected to the blower casing must not be screwed into the area where the power wiring is located. Drills or sharp screw points can damage insulation on wires located inside unit.

Secure the supply and return ductwork to the unit flanges, using proper fasteners for the type of duct used and tape the duct-to-unit joint as required to prevent air leaks.

## ! WARNING

### PERSONAL INJURY HAZARD

If appliances connected via an air duct system to one or more rooms are installed in a room with an area less than shown in Annex A table 2-2, that room shall be without continuously operating open flames (e.g. an operating gas appliance) or other potential ignition sources (for example, an operating electric heater, hot surfaces). A flame-producing device may be installed in the same space if the device is provided with an effective flame arrest. For appliances connected via an air duct system to one or more rooms, auxiliary devices which may be a potential ignition source shall not be installed in the ductwork. Examples of such potential ignition sources are hot surfaces with a temperature exceeding 700°C and electric switching devices. For appliances connected via an air duct system to one or more rooms, only auxiliary devices approved by the appliance manufacturer or declared suitable with the refrigerant shall be installed in connecting ductwork.

### Refrigerant Pipe-work

The suction pipe and liquid pipe of the indoor unit need to be protected and cannot be grabbed when moving the indoor unit.

Keep the coil connections sealed until refrigerant connections are made. See the Installation Instructions for the outdoor unit for details on line sizing, tubing installation, and charging information.

Coil is shipped with Nitrogen. Evacuate the system before charging with refrigerant.

Install refrigerant tubing so that it does not block service access to the front of the unit.

Nitrogen should flow through the refrigerant lines while brazing.

Use a brazing shield to protect the cabinet's paint and a wet rag to protect the rubber grommet and input pipe's TXV seal ring from being damaged by torch flames.

After the refrigerant connections are made, seal the gap around the connections with pressure sensitive gasket.

The pipe-work including piping material, pipe routing, and installation shall include protection from physical damage in operation and service, and be in compliance with national and local codes and standards, such as ASHRAE 15, ASHRAE 15.2, IAPMO Uniform Mechanical Code, ICC International Mechanical Code. Inspection prior to being covered or enclosed, or CSA B52. All field joints shall be accessible for inspection prior to being covered or enclosed.

All joints made in the installation between parts of the refrigerating system, with at least one part charged, shall be made in accordance with the following:

— A brazed, welded, or mechanical connection shall be made before opening the valve to permit refrigerant to flow between the refrigerating system parts. A vacuum valve shall be provided to evacuate the interconnecting pipe or any uncharged refrigerating system part.

— Mechanical connectors used indoors shall comply with ISO 14903. When mechanical connectors are reused indoors, sealing parts shall be renewed. When flared joints are reused indoors, the flare part shall be refabricated.

— Refrigerant tubing shall be protected or enclosed to avoid damage.

— Flexible refrigerant connectors (such as connecting lines between the indoor and outdoor unit) that may be displaced during normal operations shall be protected against mechanical damage.

Compliance is checked according to the installation instructions and at final installation, if necessary.

Field-made refrigerant joints indoors shall be tightness tested. The test method shall have a sensitivity of 5 grams per year of refrigerant or better under a pressure of at least 0.25 times the maximum allowable pressure. No leak shall be detected.

After completion of field piping for split systems, the field pipe-work shall be pressure tested with an inert gas and then vacuum tested prior to refrigerant charging, according to the following requirements. The minimum test pressure for the low side of the system shall be the low side design pressure and the minimum test pressure for the high side of the system shall be the high side design pressure, unless the high side of the system, can not be isolated from the low side of the system in which case the entire system shall be pressure tested to the low side design pressure.

— Mechanical joints in compliance with ISO 14903 or UL 207 (U.S. only).

— Welded or brazed joints.

— Joints in enclosures that vent to the unit or to the outside. Compliance is checked by inspection and tests.

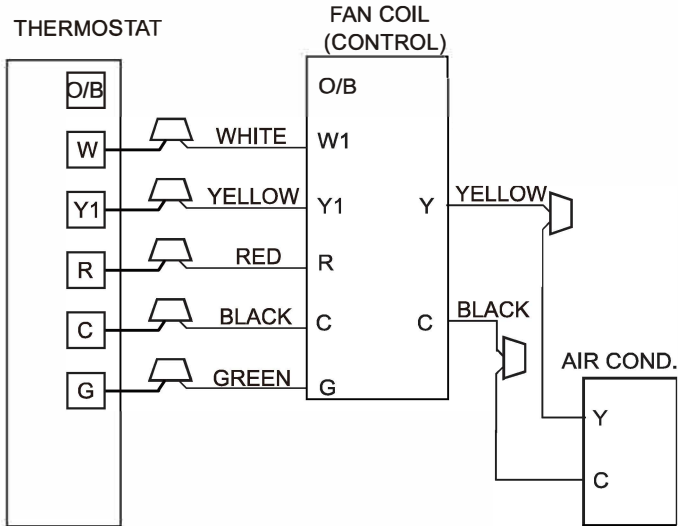

**Fig. 11 – Wiring Layout Air Conditioning Unit (Cooling and 1-Stage Heat)**

A150158A

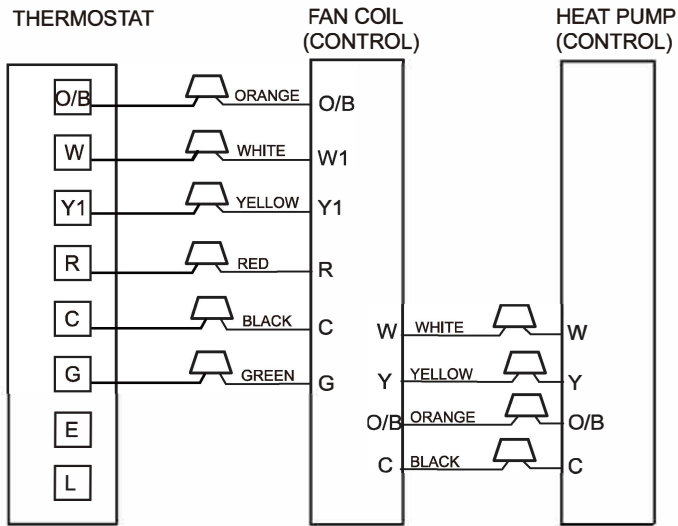

**Fig. 12 – Wiring Layout Heat Pump Unit (Cooling and 2-Stage Heat)**

A150159A

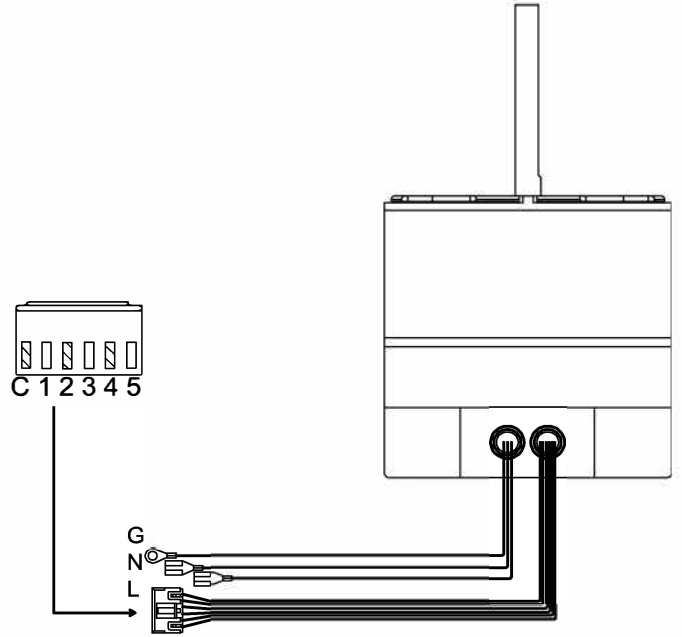

**Fig. 13 – CWM7(E) ECM Motor Speed Taps**

A11048A

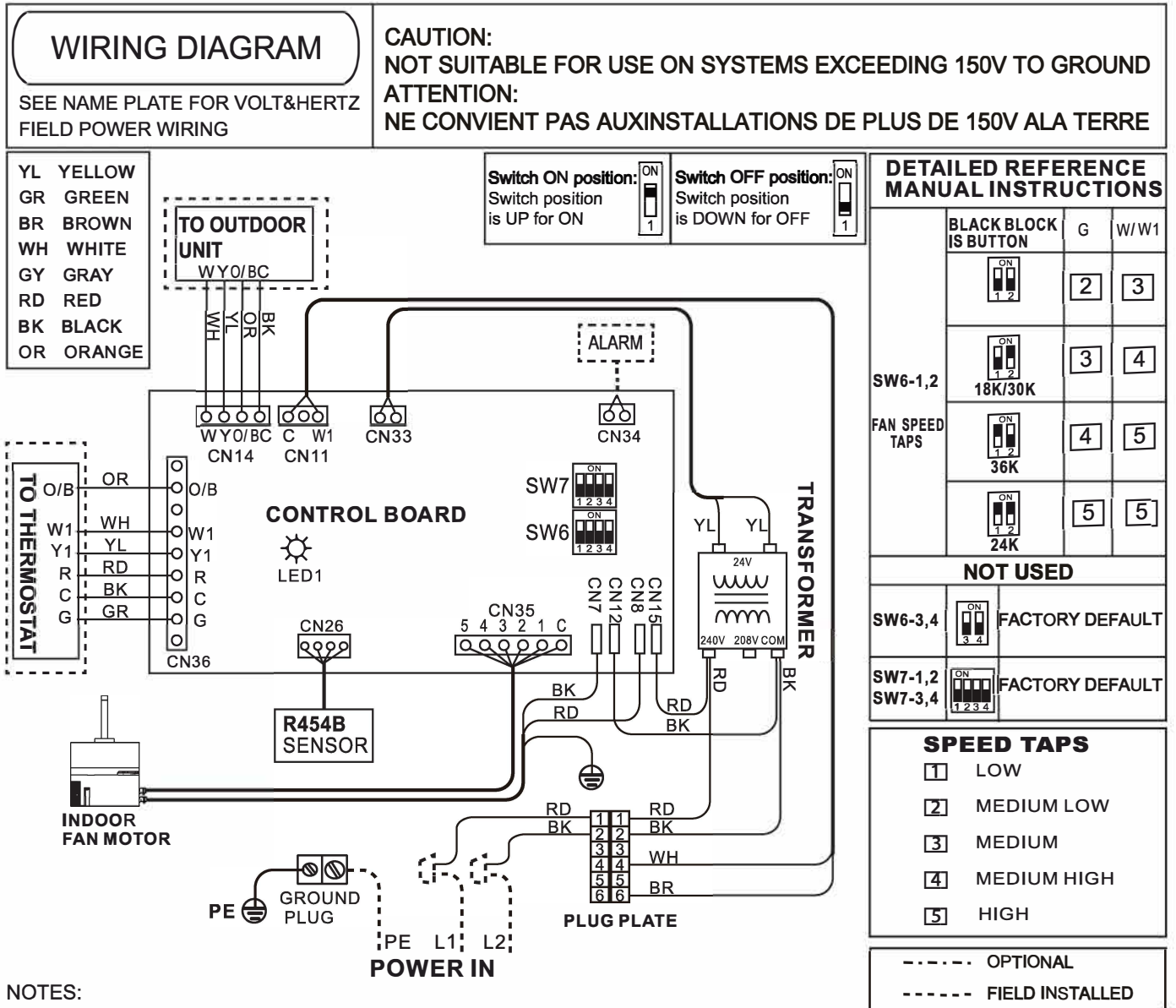



### WIRING DIAGRAM

SEE NAME PLATE FOR VOLT&HERTZ  
FIELD POWER WIRING

**CAUTION:**  
NOT SUITABLE FOR USE ON SYSTEMS EXCEEDING 150V TO GROUND

**ATTENTION:**  
NE CONVIENT PAS AUX INSTALLATIONS DE PLUS DE 150V ALA TERRE

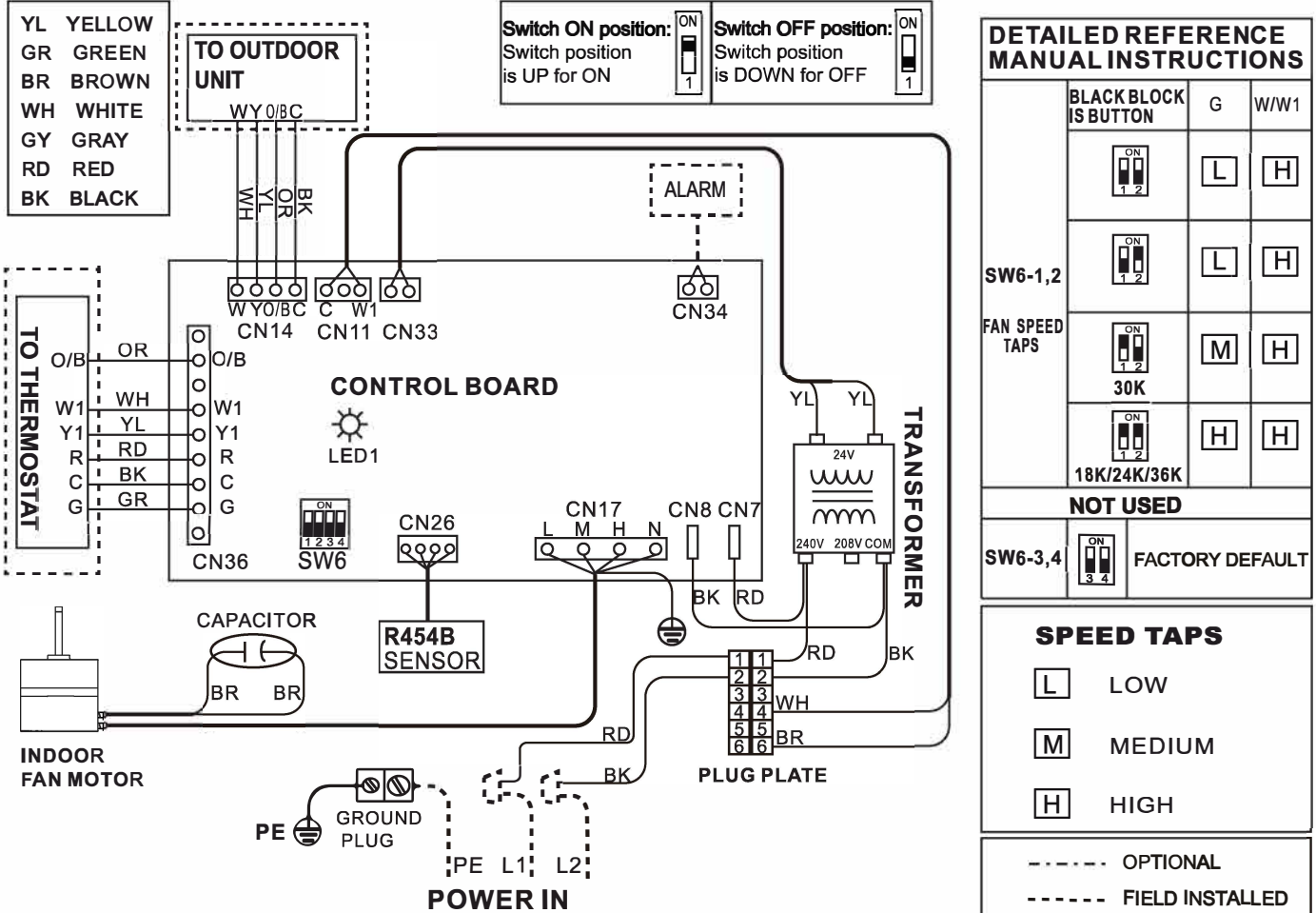

- NOTES:**
- 1: Connect R to R, G to G, Y to Y, etc. See outdoor instruction for details.
  - 2: If some signal lines of **CN36** are not used, please wrap them up separately with **CAP**.
- CAUTION:**
- 1: Use copper wire (75°C min) only between disconnect switch and unit.
  - 2: To be wired in accordance with **NEC** and local codes.
  - 3: If any of the original wires, as supplied, must be replaced. Use the same or equivalent type wires.
  - 4: If the input voltage is 208 V, please change the transformer tap by taking the red wire to **208V** terminal.
  - 5: The rated operating condition of **Alarm** is 24 VAC/1A or 30 VDC/1A or 250 VAC/1A. Please refer to the manual for wiring methods.

LED1 STATUS	CONTENT	CONTENT
	STEADY ON	NORMAL OPERATION
	OFF	POWER SUPPLY FAILURE
	STEADY FLASHING	DISSIPATION MODE ACTIVE
	3 FLASH/CYCLE	R454B REFRIGERANT SENSOR FAULT
	4 FLASH/CYCLE	R454B REFRIGERANT SENSOR COMMUNICATION FAULT
	8 FLASH/CYCLE	R454B REFRIGERANT SENSOR OVER SERVICE LIFE

**Fig. 15 – CWM7(P) (PSC motor) Schematic**

A230608

**Table 11 – PSC -Airflow Performance (Standard CFM)**

MODEL (SIZE, TON)	BLOWER SPEEDS	EXTERNAL STATIC PRESSURE (IN WC.)								
		0	0.1	0.2	0.3	0.4	0.5	0.6	0.7	0.8
18 (1-1/2)	Low	604	562	527	485	441	387	-	-	-
	Med	697	655	619	577	533	479	426	380	-
	High - Factory	802	761	721	682	637	592	541	481	408
24 (2)	Low	665	629	589	547	508	480	-	-	-
	Med	831	786	741	696	655	609	559	497	-
	High - Factory	932	881	833	786	742	689	636	574	515
30 (2-1/2)	Low	988	948	900	862	816	772	719	642	613
	Med - Factory	1197	1152	1097	1046	998	940	886	821	737
	High	1338	1284	1220	1159	1096	1029	960	879	792
36 (3)	Low	1118	1072	1018	971	920	876	819	759	693
	Med	1262	1213	1160	1098	1049	998	937	871	804
	High - Factory	1360	1311	1263	1229	1166	1074	1005	934	867

- NOTES: Shaded boxes represent airflow outside the required 300-450 CFM/ton.

1. Airflow data includes electric heat and filter.
2. Airflow data is with no return grill. When using a return grill on 18 & 24 sizes, decrease numbers above by approx. 10 CFM. For 30 & 36 sizes, decrease numbers above by approx. 50 CFM

**Table 12 – ECM - Airflow Performance (Standard CFM)**

MODEL (SIZE, TON)	BLOWER SPEEDS	EXTERNAL STATIC PRESSURE (IN WC.)								
		0	0.1	0.2	0.3	0.4	0.5	0.6	0.7	0.8
18 (1-1/2)	Tap (1)	584	541	487	441	416	357	359	299	253
	Tap (2)	662	615	582	542	514	467	427	385	351
	Tap (3) - Factory	710	683	645	619	579	535	490	458	416
	Tap (4)	803	769	742	710	675	642	609	572	534
	Tap (5)	899	871	836	810	789	758	719	689	646
24 (2)	Tap (1)	584	541	487	441	416	357	359	299	253
	Tap (2)	662	615	582	542	514	467	427	385	351
	Tap (3)	710	683	645	619	579	535	490	458	416
	Tap (4)	803	769	742	710	675	642	609	572	534
	Tap (5) - Factory	899	871	836	810	789	758	719	689	646
30 (2-1/2)	Tap (1)	1063	1012	936	898	853	823	780	740	701
	Tap (2)	1133	1080	1026	991	958	904	858	813	769
	Tap (3) - Factory	1220	1194	1111	1100	1060	1007	952	910	855
	Tap (4)	1234	1200	1146	1229	1088	1046	1004	951	917
	Tap (5)	1341	1310	1247	1225	1192	1151	1101	1077	1033
36 (3)	Tap (1)	1063	1012	936	898	853	823	780	740	701
	Tap (2)	1133	1080	1026	991	958	904	858	813	769
	Tap (3)	1220	1194	1111	1100	1060	1007	952	910	855
	Tap (4) - Factory	1234	1200	1146	1229	1088	1046	1004	951	917
	Tap (5)	1341	1310	1247	1225	1192	1151	1101	1077	1033

- NOTES: Shaded boxes represent airflow outside the required 300-450 CFM/ton.

1. Airflow based upon dry coil at 230V with no electric heat and factory-approved filter. For MHVE airflow at 208V is approximately the same as 230V because the multi-tap ECM motor is a constant torque motor. The torque doesn't drop off at the speeds in which the motor operates.
2. Airflow is equivalent for front or bottom return configurations.







