ComfortStar®

Service manual

Wall Hung Air Handler Units

(ECM/PSC)

CWM7(E)(P)



1. System instructions

1.1 Refrigerant Circuit

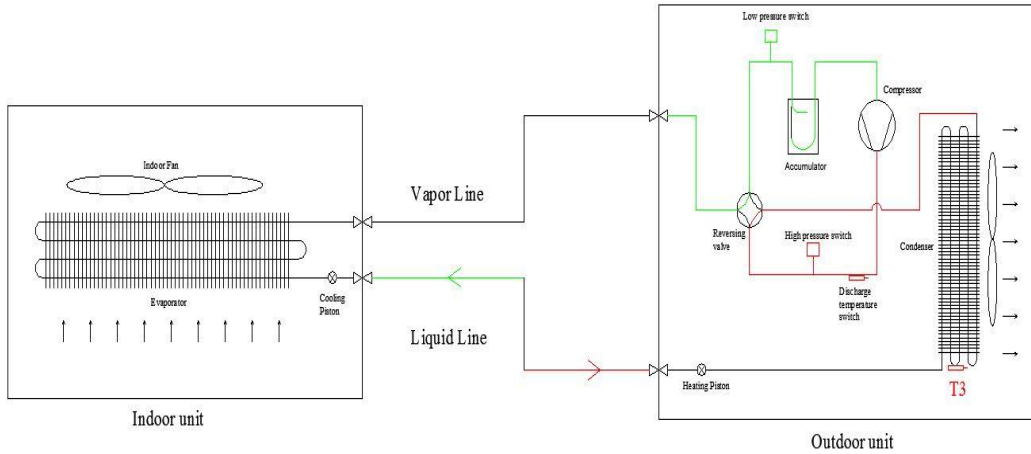
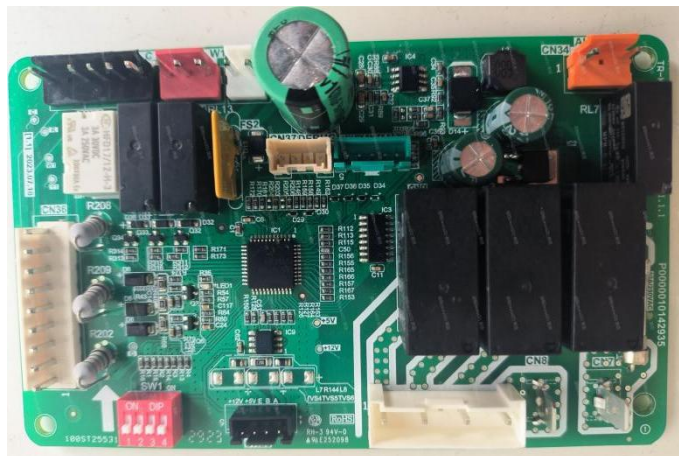

Fig. 1 Refrigerant Circuit

2. PCB Board

2.1 PCB Board for ECM unit



Label	Port code	Content	Port voltage
1	CN7	Power supply line	208-230V AC
2	CN8	Power supply line	208-230V AC
3	CN17	PSC Motor line	208-230V AC
4	CN26	Refrigerant leak detector	0-5V AC
5	CN36	Thermostat signal line	0-24V AC
6	CN14	Signal port to ODU	208-230V AC
7	CN11	Signal port to heater	0-24V AC
8	CN33	Signal power source	0-24V AC
9	CN34	Passive alarm signal port	Max 1A

2.2 PCB Board for ECM unit



Label	Port code	Content	Port voltage
1	CN7	Power supply line	208-230V AC
2	CN8	Power supply line	208-230V AC
3	CN12	ECM motor power supply line	208-230V AC
4	CN15	ECM motor power supply line	208-230V AC
5	CN35	ECM motor speed control signal	0-24V AC
6	CN26	Refrigerant leak detector	0-5V AC
7	CN36	Thermostat signal line	0-24V AC
8	CN14	Signal port to ODU	208-230V AC
9	CN11	Signal port to heater	0-24V AC
10	CN33	Signal power source	0-24V AC
11	CN34	Passive alarm signal port	Max 1A

3. Refrigerant leak sensor

3.1 Sensor model: 7-R454B-L



3.2 Installation location

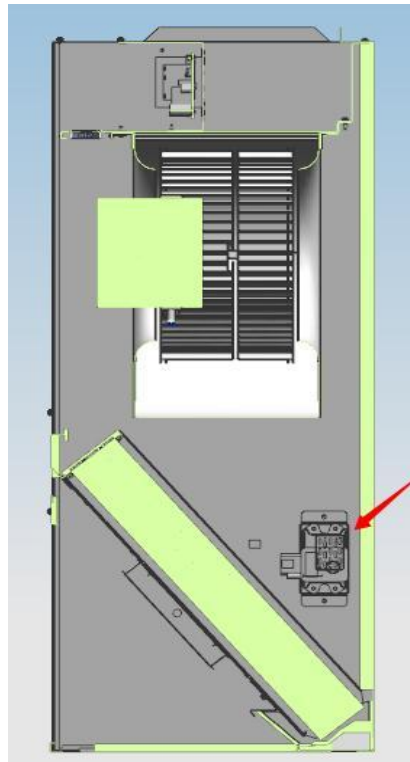

NO.	Content	Description
1	Refrigerant	R454B
2	Detection range	0 ~ 100% LFL
3	DTLV	10% LFL
4	Operating temperature range	-40°C ~ 80°C
5	Operating humidity range	0-95% RH
6	Service life	15years
7	Voltage	5V DC
8	Max current	< 100mA
9	Output port	RS485

4. Dip switch

4.1 Dip switch for ECM unit

The blower speed (ECM) is selected through the dip switch (SW6-1,2) on the PCB board as shown below.

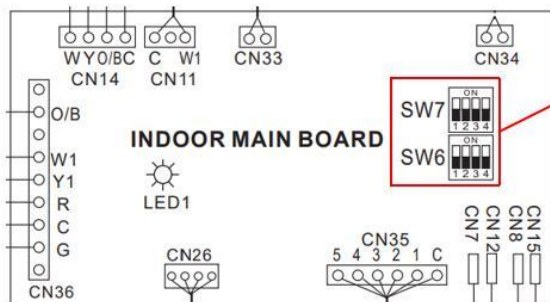

DETAILED REFERENCE MANUAL INSTRUCTIONS			
SW6-1,2 FAN SPEED TAPS	BLACK BLOCK IS BUTTON	G	W/W1
		2	3
		3	4
		4	5
		5	5
NOT USED			
SW6-3,4		FACTORY DEFAULT	
SW7-1,2 SW7-3,4		FACTORY DEFAULT	

4.2 Dip switch for PSC unit

The blower speed (ECM) is selected through the dip switch (SW6-1,2) on the PCB board as shown below.

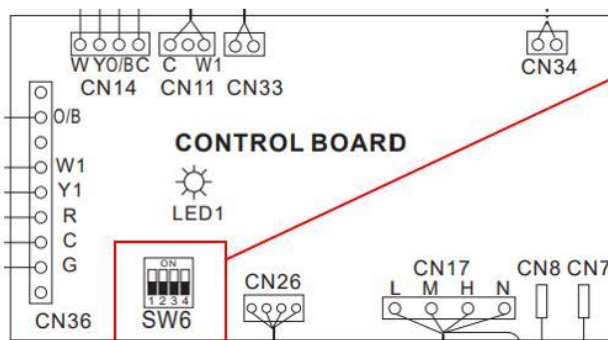

DETAILED REFERENCE MANUAL INSTRUCTIONS			
SW6-1,2 FAN SPEED TAPS	BLACK BLOCK IS BUTTON	G	W/W1
		L	H
		L	H
		M	H
		H	H
SW6-3		0S OFF-DELAY	
		90S OFF-DELAY (FACTORY DEFAULT)	
NOT USED			
SW6-4		FACTORY DEFAULT	

5. Indoor unit Fault Control

5.1 LED1 status

When Indoor unit can't operate normally, check the LED status.

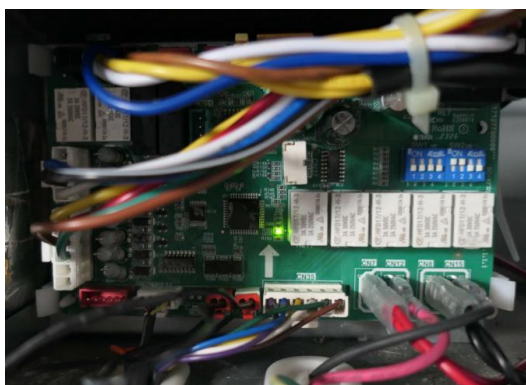

Green light LED on PCB board

No.	Mode	Description
1	Steady on	Functioning
2	Keep flashing	Refrigerant leak protection
3	OFF	Power supply failure
4	3 FLASH/CYCLE	A2L sensor hardware error
5	4 FLASH/CYCLE	A2L sensor communication error
6	8 FLASH/CYCLE	A2L sensor over service life

5.1.1 LED for ECM Unit

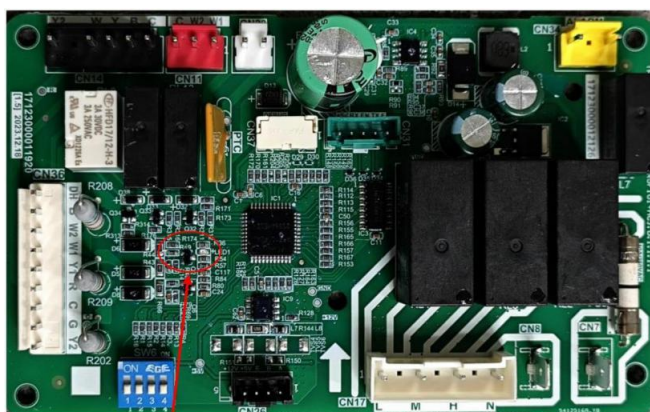

LED1

5.1.2 LED for ECM Unit

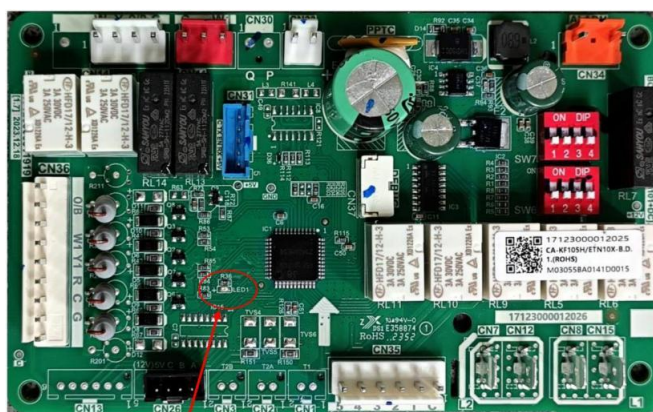

LED1

5.2 Unit fault control

The unit LED will flash when the unit is abnormal. To protect itself, the unit shutdown until the abnormal condition is corrected.

No.	LED light flash	Fault code description	Supposed cause
2	KEEP FLASHING	Refrigerant leak protection	Refrigerant leak
4	3FLASH/CYCLE	A2l refrigerant sensor fault	A2L sensor fault
5	4FLASH/CYCLE	A2l refrigerant sensor communication fault	Wiring error/A2L sensor fault
6	8 FLASH/CYCLE	A2L sensor over service life	The sensor has been working for more than 15 years

Note: When failure condition vanishing, system can resume operation except as specified. The abnormal condition must be corrected by the Professional technical support.

5.2.1 A2L refrigerant sensor fault (A2L sensor)

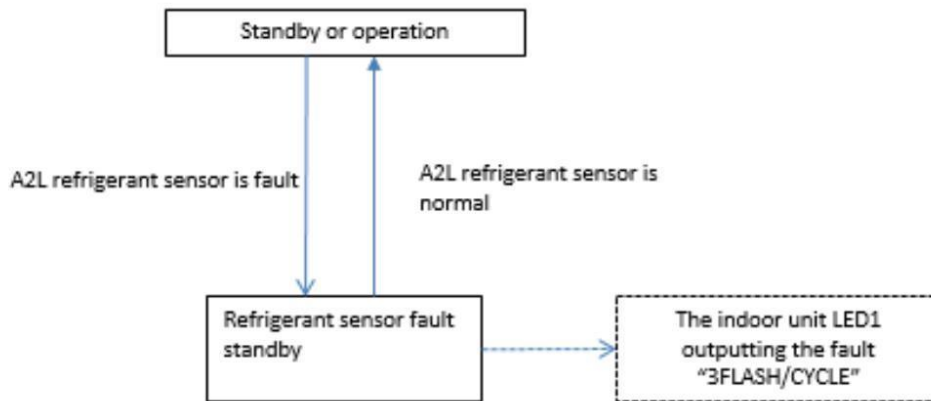

5.2.2 A2L sensor communication fault (A2L sensor)

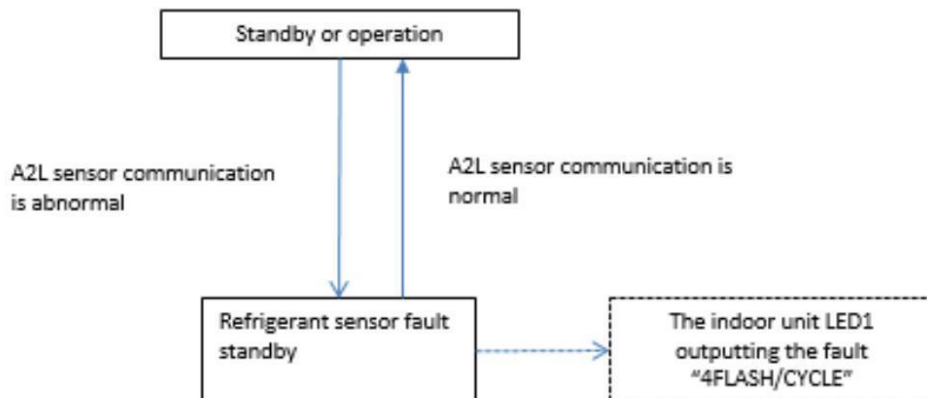

5.2.3 Refrigerant leakage fault in indoor unit

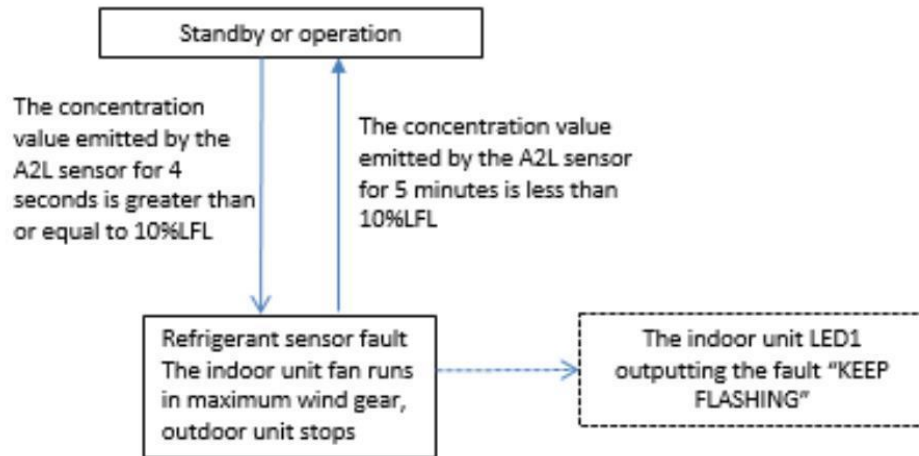

5.2.4 A2L sensor over service life in indoor unit

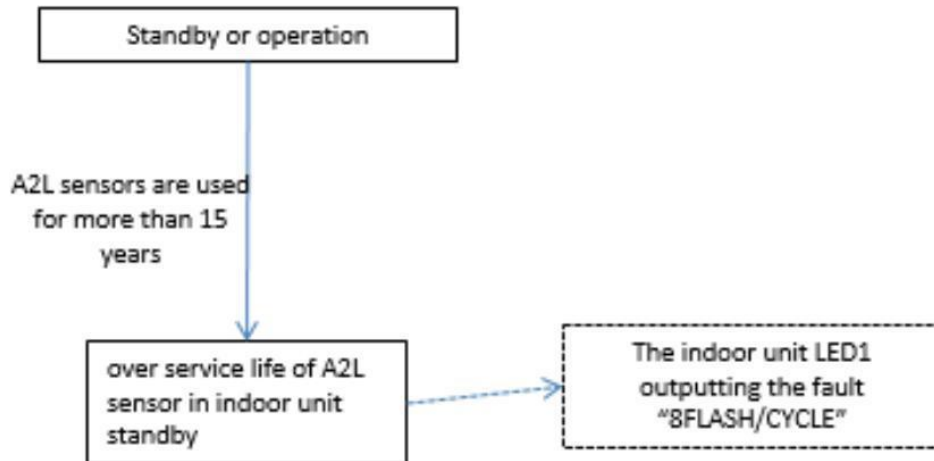

6. Indoor unit Trouble Shooting

6.1 System does not start operation

Issue	System does not start operation
Model	All
Fault name	/
Classify	Thermostat fault
Possible cause	<ul style="list-style-type: none"> • The thermostat doesn't start • Wrong wire connections between thermostat and unit • Damaged thermostat • Wrong/Damaged wire connections between IDU and ODU • Damaged IDU/ODU PCB • Disconnect the compressor wire (could be caused after service)
Notes:	

Troubleshooting

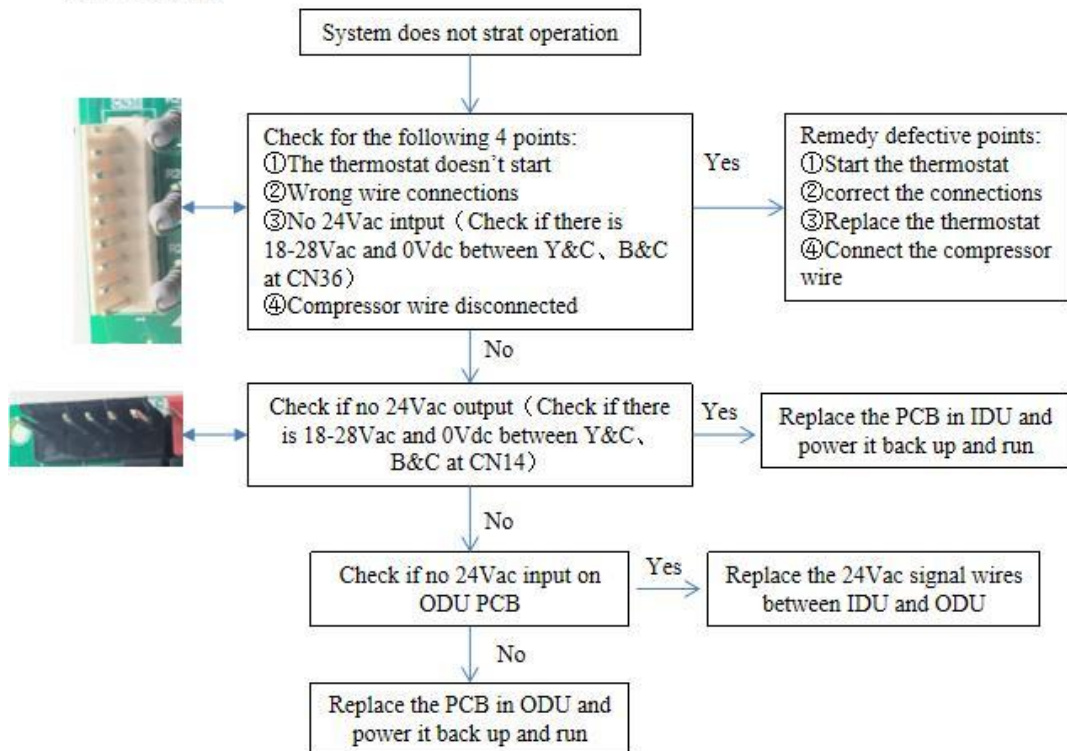

6.2 3 flash/cycle Fault

Faulty code	3 flash/cycle
Model	All
Name	R454B sensor fault in IDU
Classify	Sensor fault
Possible cause	<ul style="list-style-type: none">• Sensors failed• Beyond the normal operating temperature range

Troubleshooting

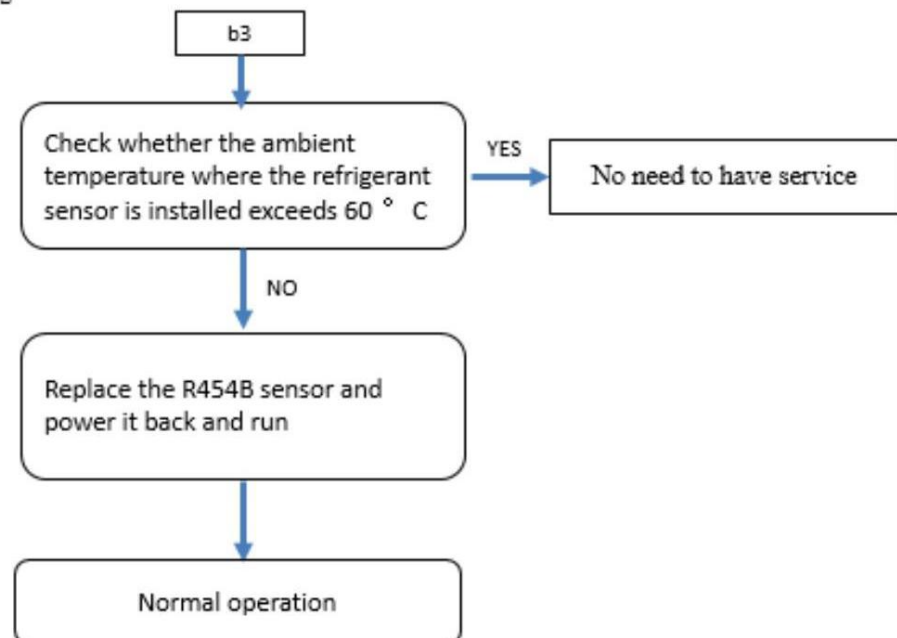

6.3 4 flash/cycle Fault

Faulty code	4 flash/cycle
Model	IDU
Name	R454B sensor communication fault in IDU
Classify	Electric issue
Possible cause	- refrigerant sensor line connection in IDU abnormal: refrigerant sensor signal line in IDU is not properly plugged (CN26) - Refrigerant sensor in IDU abnormal: damaged

Troubleshooting

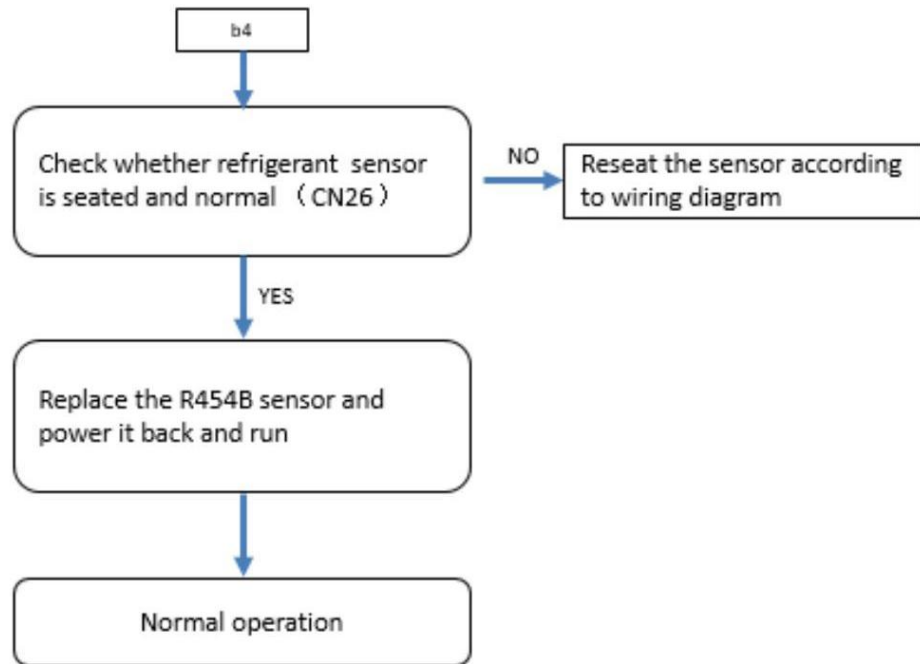

6.4 8 flash/cycle Fault

Faulty code	8 flash/cycle
Model	All
Name	R454B sensor over service life
Classify	Sensor fault
Possible cause	• Over service

Troubleshooting

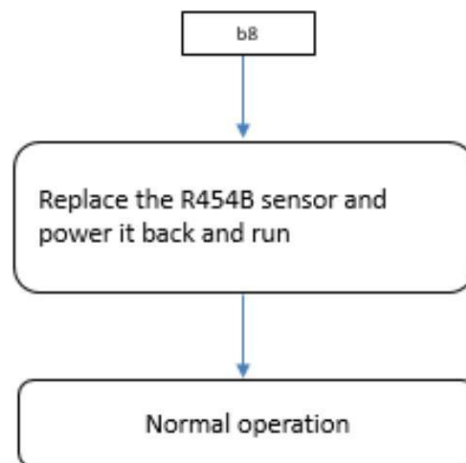

6.5 Keep flashing

Faulty code	Keep flashing
Model	All
Name	Refrigerant leakage fault
Classify	Refrigerant leakage
Possible cause	• Refrigerant leakage

Troubleshooting

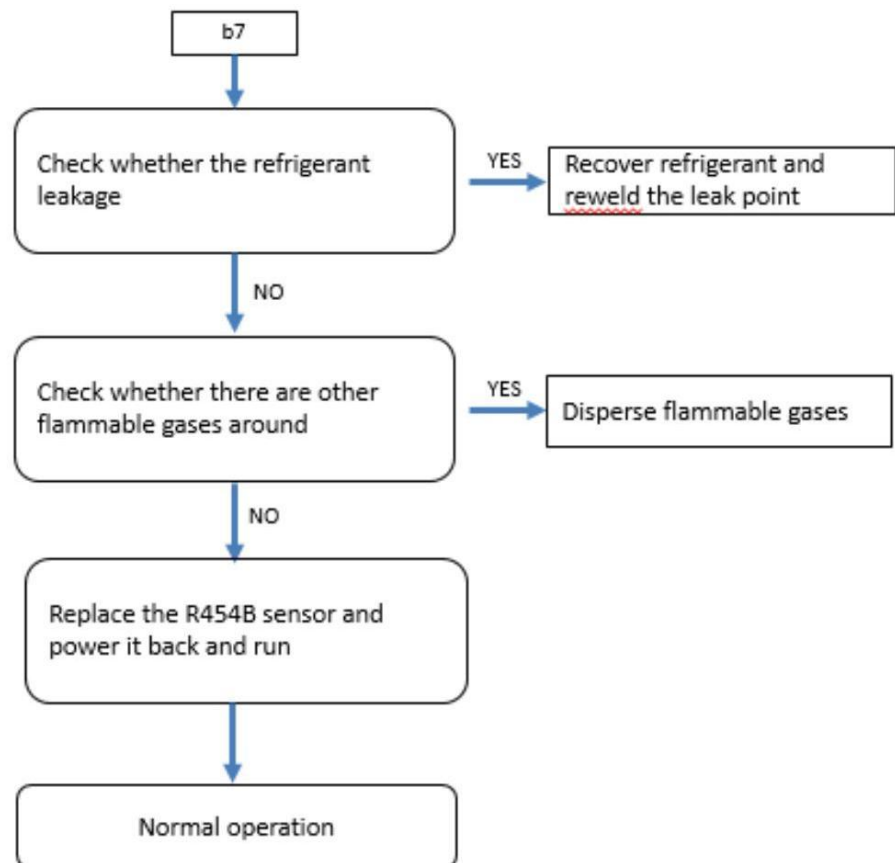

7. Repair Guide

How to remove the refrigerant sensor?

Step1: Loosen the two screws on the panel and remove the front cover.

Step2: Remove the wiring of the refrigerant sensor and blower on the PCB.

Step3: Remove the wire through the threading hole.

Step4: Loosen the screws from the top of the blower.

Step5: Hold the motor bracket and remove the blower.

Step6: Loosen the sensor fastening screw and remove the sensor.

